

## CURRENT-LIMITED POWER-DISTRIBUTION SWITCH

Check for Samples: [TPS2041B-EP](#)

### FEATURES

- 70-mΩ High-Side MOSFET
- 500-mA Continuous Current
- Thermal and Short-Circuit Protection
- Current Limit:  
0.45 A (Min), 1.55 A (Max)
- Operating Range: 2.7 V to 5.5 V
- 0.6-ms Typical Rise Time
- Undervoltage Lockout
- Deglitched Fault Report ( $\overline{OC}$ )
- No  $\overline{OC}$  Glitch During Power Up
- Maximum Standby Supply Current: 1  $\mu$ A
- Bidirectional Switch
- ESD Protection Level Per AEC-Q100 Classification
- UL Recognized, File Number E169910

### APPLICATIONS

- Heavy Capacitive Loads
- Short-Circuit Protection

### SUPPORTS DEFENSE, AEROSPACE, AND MEDICAL APPLICATIONS

- Controlled Baseline
- One Assembly/Test Site
- One Fabrication Site
- Available in Military ( $-55^{\circ}\text{C}/125^{\circ}\text{C}$ ) Temperature Range
- Extended Product Life Cycle
- Extended Product-Change Notification
- Product Traceability

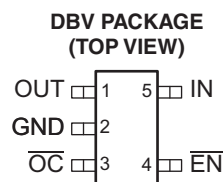

### DESCRIPTION

The TPS2041B power-distribution switch is intended for applications where heavy capacitive loads and short circuits are likely to be encountered. This device incorporates 70-mΩ N-channel MOSFET power switches for power-distribution systems that require multiple power switches in a single package. Each switch is controlled by a logic enable input. Gate drive is provided by an internal charge pump designed to control the power-switch rise times and fall times to minimize current surges during switching. The charge pump requires no external components and allows operation from supplies as low as 2.7 V.

When the output load exceeds the current-limit threshold or a short is present, the device limits the output current to a safe level by switching into a constant-current mode, pulling the overcurrent ( $\overline{OC}$ ) logic output low. When continuous heavy overloads and short circuits increase the power dissipation in the switch, causing the junction temperature to rise, a thermal protection circuit shuts off the switch to prevent damage. Recovery from a thermal shutdown is automatic once the device has cooled sufficiently. Internal circuitry ensures that the switch remains off until valid input voltage is present. This power-distribution switch is designed to set current limit at 1 A (typ).



Please be aware that an important notice concerning availability, standard warranty, and use in critical applications of Texas Instruments semiconductor products and disclaimers thereto appears at the end of this data sheet.



This integrated circuit can be damaged by ESD. Texas Instruments recommends that all integrated circuits be handled with appropriate precautions. Failure to observe proper handling and installation procedures can cause damage.

ESD damage can range from subtle performance degradation to complete device failure. Precision integrated circuits may be more susceptible to damage because very small parametric changes could cause the device not to meet its published specifications.

### ORDERING INFORMATION<sup>(1)</sup>

T <sub>J</sub>	ENABLE	NO. OF SWITCHES	PACKAGE <sup>(2)</sup>	ORDERABLE PART NUMBER	TOP-SIDE MARKING	VID NUMBER
-55°C to 125°C	Active low	Single	SOT-23 – DBV	TPS2041BMDVBTEP	PXAM	V62/11620-01XE

- (1) For the most current package and ordering information, see the Package Option Addendum at the end of this document, or see the TI web site at [www.ti.com](http://www.ti.com).
- (2) Package drawings, thermal data, and symbolization are available at [www.ti.com/packaging](http://www.ti.com/packaging).

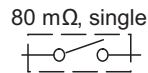

Figure 1. TPS2041B Switch at 500 mA

### ABSOLUTE MAXIMUM RATINGS<sup>(1)</sup>

over operating free-air temperature range unless otherwise noted

V <sub>I(IN)</sub>	Input voltage range (IN) <sup>(2)</sup>	-0.3 V to 6 V
V <sub>O(OUT)</sub>	Output voltage range (OUT) <sup>(2)</sup>	-0.3 V to 6 V
V <sub>I(EN)</sub>	Input voltage range (EN)	-0.3 V to 6 V
V <sub>I(OC)</sub>	Voltage range (OC)	-0.3 V to 6 V
I <sub>O(OUT)</sub>	Continuous output current	Internally limited
	Continuous power dissipation at 125°C	182 mW
θ <sub>JC</sub>	Thermal resistance, junction-to-case	55°C/W
T <sub>J</sub>	Operating virtual-junction temperature range	-55°C to 135°C
T <sub>stg</sub>	Storage temperature range	-65°C to 150°C
	Lead temperature, soldering	1,6 mm (1/16 in) from case for 10 s 260°C
	Electrostatic discharge (ESD) protection	Human-Body Model (HBM) (H2) 2500 V
		Machine Model (MM) (M0) 50 V
		Charged-Device Model (CDM) (C5) 1500 V

- (1) Stresses beyond those listed under *absolute maximum ratings* may cause permanent damage to the device. These are stress ratings only, and functional operation of the device at these or any other conditions beyond those indicated under *recommended operating conditions* is not implied. Exposure to absolute-maximum-rated conditions for extended periods may affect device reliability.
- (2) All voltages are with respect to GND.

### RECOMMENDED OPERATING CONDITIONS

		MIN	MAX	UNIT
V <sub>I(IN)</sub>	Input voltage (IN)	2.7	5.5	V
V <sub>I(EN)</sub>	Input voltage (EN)	0	5.5	V
I <sub>O(OUT)</sub>	Continuous output current (OUT)	0	500	mA
T <sub>J</sub>	Operating virtual-junction temperature	-55	125	°C

## ELECTRICAL CHARACTERISTICS

over recommended operating junction temperature range,  $V_{I(IN)} = 5.5\text{ V}$ ,  $I_O = 0.5\text{ A}$ ,  $V_{I(\overline{EN})} = 0\text{ V}$  (unless otherwise noted)

PARAMETER		TEST CONDITIONS <sup>(1)</sup>		MIN	TYP	MAX	UNIT
<b>Power Switch</b>							
$r_{DS(on)}$	Static drain-source on-state resistance, 5-V or 3.3-V operation	$V_{I(IN)} = 5\text{ V}$ or $3.3\text{ V}$ , $I_O = 0.5\text{ A}$	$-55^\circ\text{C} \leq T_J \leq 125^\circ\text{C}$	70	135		m $\Omega$
	Static drain-source on-state resistance, 2.7-V operation	$V_{I(IN)} = 2.7\text{ V}$ , $I_O = 0.5\text{ A}$	$-55^\circ\text{C} \leq T_J \leq 125^\circ\text{C}$	75	150		
$t_r$	Rise time, output	$V_{I(IN)} = 5.5\text{ V}$ $V_{I(IN)} = 2.7\text{ V}$	$C_L = 1\text{ }\mu\text{F}$ , $R_L = 10\text{ }\Omega$  $T_J = 25^\circ\text{C}$	0.6			ms
$t_f$	Fall time, output	$V_{I(IN)} = 5.5\text{ V}$ $V_{I(IN)} = 2.7\text{ V}$		0.4			
				0.2			
				0.2			
<b>Enable Input (<math>\overline{EN}</math>)</b>							
$V_{IH}$	High-level input voltage	$2.7\text{ V} \leq V_{I(IN)} \leq 5.5\text{ V}$		2			V
$V_{IL}$	Low-level input voltage	$2.7\text{ V} \leq V_{I(IN)} \leq 5.5\text{ V}$				0.8	V
$I_I$	Input current	$V_{I(\overline{EN})} = 0\text{ V}$ or $5.5\text{ V}$		-1		1	$\mu\text{A}$
$t_{on}$	Turn-on time	$C_L = 100\text{ }\mu\text{F}$ , $R_L = 10\text{ }\Omega$			3		ms
$t_{off}$	Turn-off time	$C_L = 100\text{ }\mu\text{F}$ , $R_L = 10\text{ }\Omega$			6		ms
<b>Current Limit</b>							
$I_{OS}$	Short-circuit output current	$V_{I(IN)} = 5\text{ V}$ , OUT connected to GND, device enabled into short-circuit	$T_J = 25^\circ\text{C}$ $-55^\circ\text{C} \leq T_J \leq 125^\circ\text{C}$	0.65 0.45	1 1	1.3 1.55	A
<b>Supply Current</b>							
Supply current, low-level output		No load on OUT, $V_{I(\overline{EN})} = 5.5\text{ V}$ or $V_{I(EN)} = 0\text{ V}$	$T_J = 25^\circ\text{C}$ $-55^\circ\text{C} \leq T_J \leq 125^\circ\text{C}$	0.5 0.5	1 5		$\mu\text{A}$
Supply current, high-level output		No load on OUT, $V_{I(\overline{EN})} = 0\text{ V}$ or $V_{I(EN)} = 5.5\text{ V}$	$T_J = 25^\circ\text{C}$ $-55^\circ\text{C} \leq T_J \leq 125^\circ\text{C}$	43 43	60 70		$\mu\text{A}$
Leakage current		OUT connected to ground, $V_{I(\overline{EN})} = 5.5\text{ V}$ or $V_{I(EN)} = 0\text{ V}$	$-55^\circ\text{C} \leq T_J \leq 125^\circ\text{C}$	1			$\mu\text{A}$
Reverse leakage current		$V_{I(OUT)} = 5.5\text{ V}$ , IN = ground	$T_J = 25^\circ\text{C}$	0			$\mu\text{A}$
<b>Undervoltage Lockout</b>							
Low-level input voltage, IN				2		2.5	V
Hysteresis, IN			$T_J = 25^\circ\text{C}$	75			mV
<b>Overcurrent (<math>\overline{OC}</math>)</b>							
Output low voltage, $V_{OL(OC)}$		$I_{O(\overline{OC})} = 5\text{ mA}$			0.4		V
Off-state current		$V_{O(\overline{OC})} = 5\text{ V}$ or $3.3\text{ V}$			1		$\mu\text{A}$
$\overline{OC}$ deglitch		$\overline{OC}$ assertion or deassertion		3	8	16	ms
<b>Thermal Shutdown<sup>(2)</sup></b>							
Thermal shutdown threshold				135			$^\circ\text{C}$
Recovery from thermal shutdown				125			$^\circ\text{C}$
Hysteresis				10			$^\circ\text{C}$

(1) Pulse-testing techniques maintain junction temperature close to ambient temperature; thermal effects must be accounted for separately.

(2) The thermal shutdown only reacts under overcurrent conditions.

## DEVICE INFORMATION

### Terminal Functions

TERMINAL		I/O	DESCRIPTION
NAME	NO.		
$\overline{\text{EN}}$	4	I	Enable input, logic low turns on power switch
GND	2		Ground
IN	5	I	Input voltage
$\overline{\text{OC}}$	3	O	Overcurrent, open-drain output, active low
OUT	1	O	Power-switch output

### Functional Block Diagram

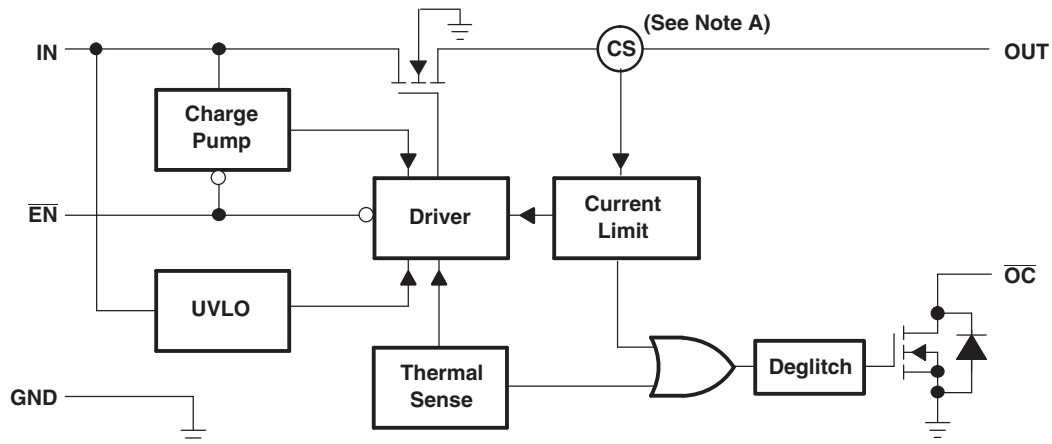

A. CS = Current sense

PARAMETER MEASUREMENT INFORMATION

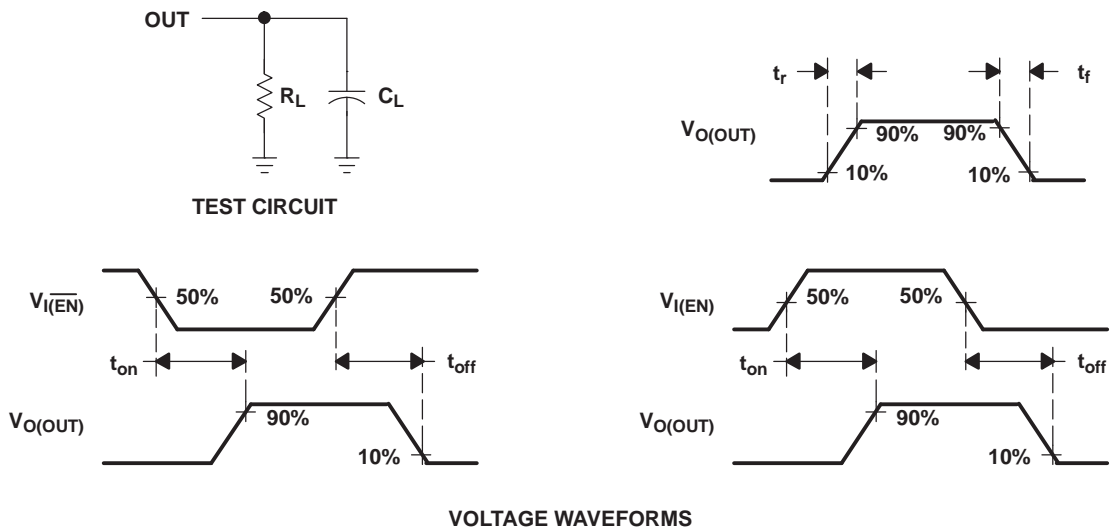

Figure 2. Test Circuit and Voltage Waveforms

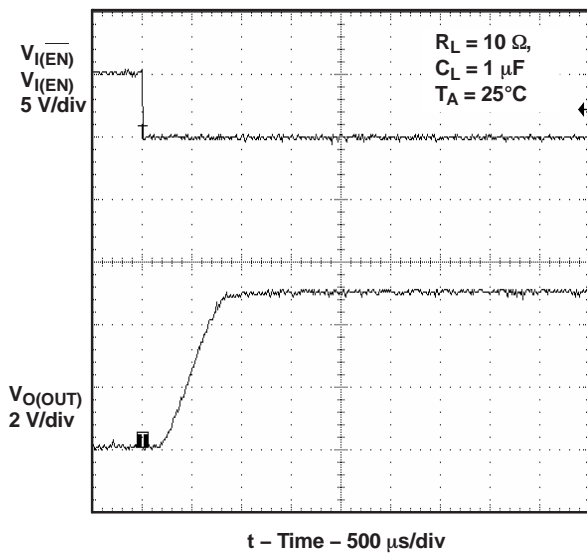

Figure 3. Turn-On Delay and Rise Time With 1- $\mu$ F Load

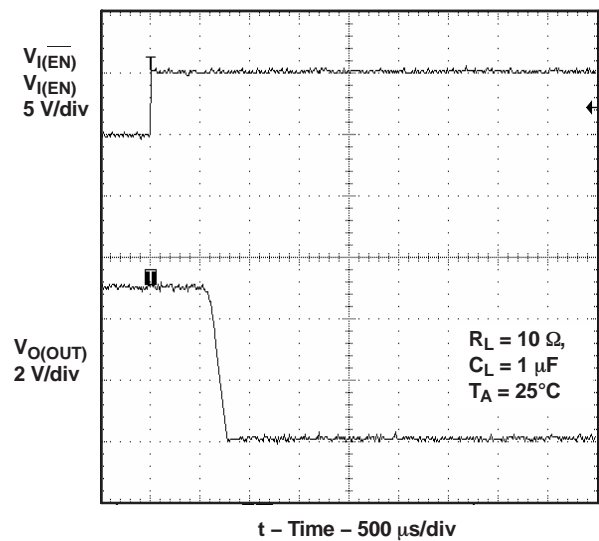

Figure 4. Turn-Off Delay and Fall Time With 1- $\mu$ F Load

PARAMETER MEASUREMENT INFORMATION (continued)

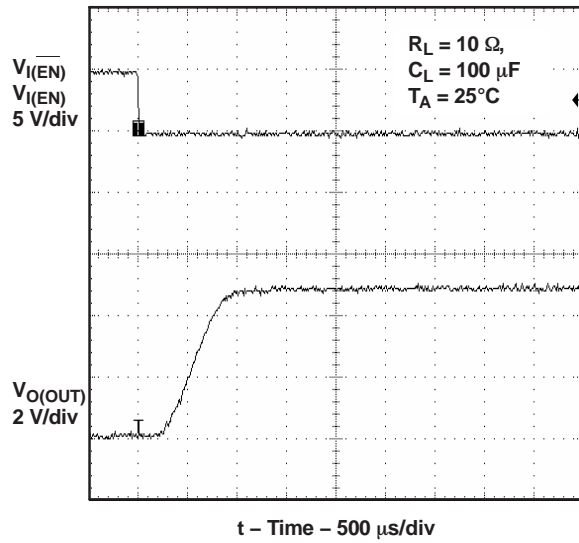

Figure 5. Turn-On Delay and Rise Time With 100-μF Load

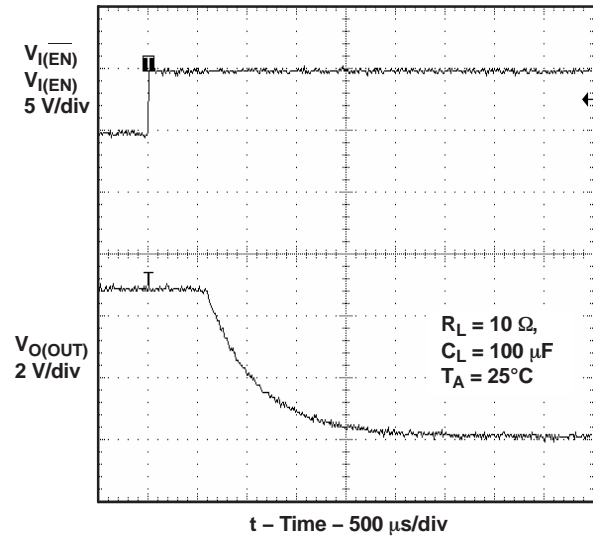

Figure 6. Turn-Off Delay and Fall Time With 100-μF Load

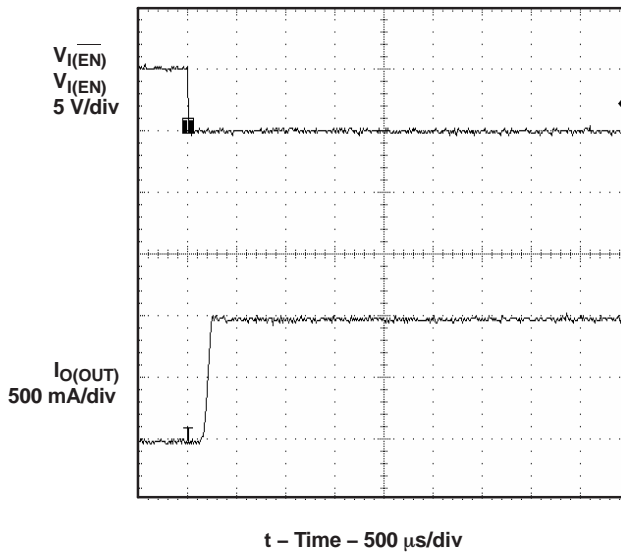

Figure 7. Short-Circuit Current, Device Enabled Into Short

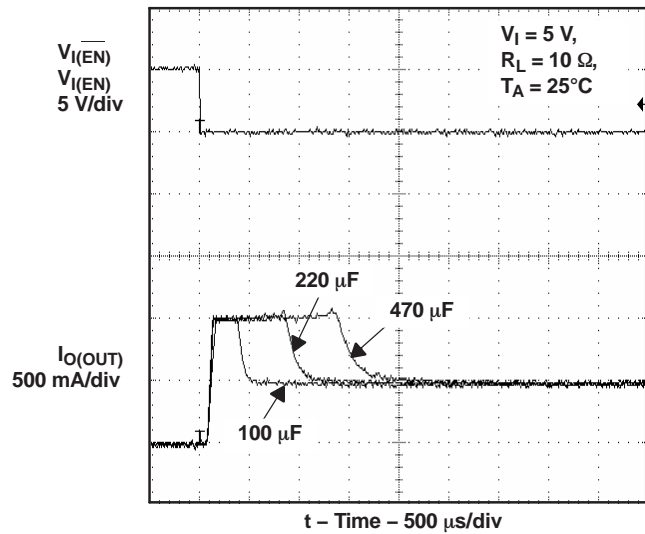

Figure 8. Inrush Current With Different Load Capacitance

PARAMETER MEASUREMENT INFORMATION (continued)

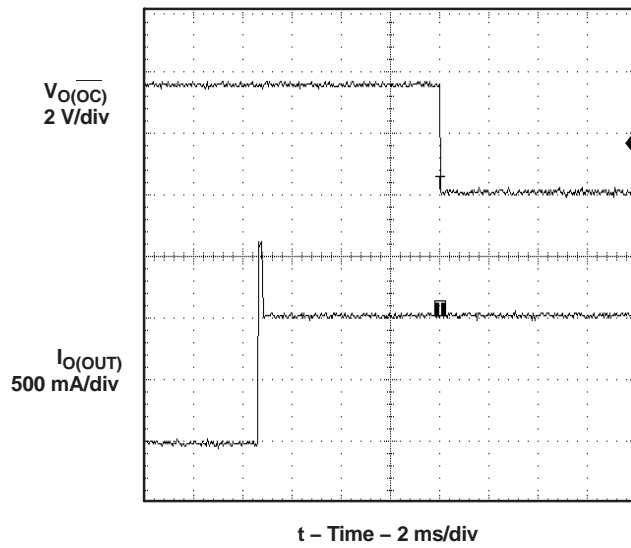

Figure 9. 3-Ω Load Connected to Enabled Device

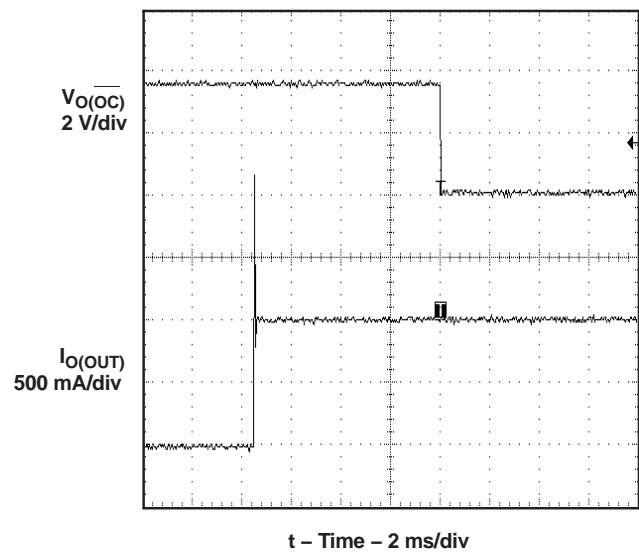

Figure 10. 2-Ω Load Connected to Enabled Device

TYPICAL CHARACTERISTICS

TURN-ON TIME  
vs  
INPUT VOLTAGE

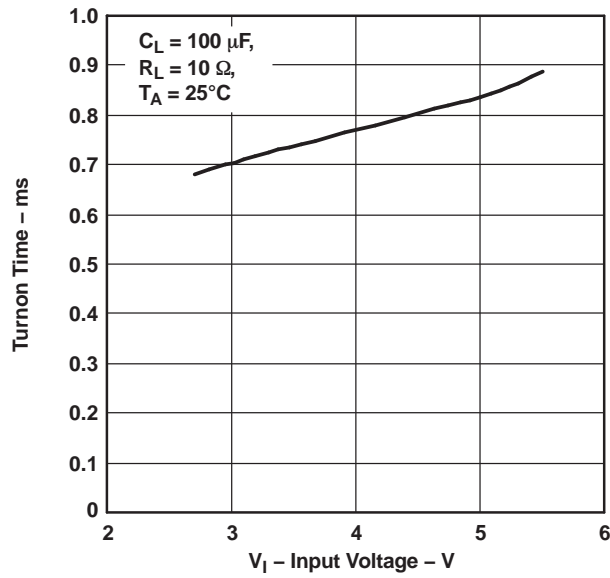

Figure 11.

TURN-OFF TIME  
vs  
INPUT VOLTAGE

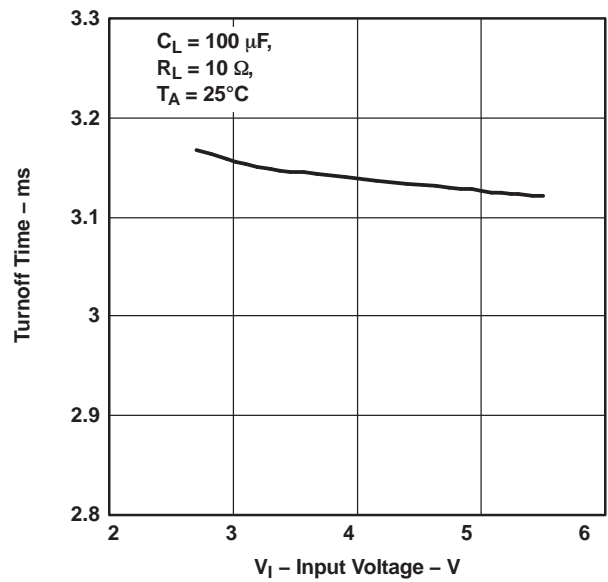

Figure 12.

RISE TIME  
vs  
INPUT VOLTAGE

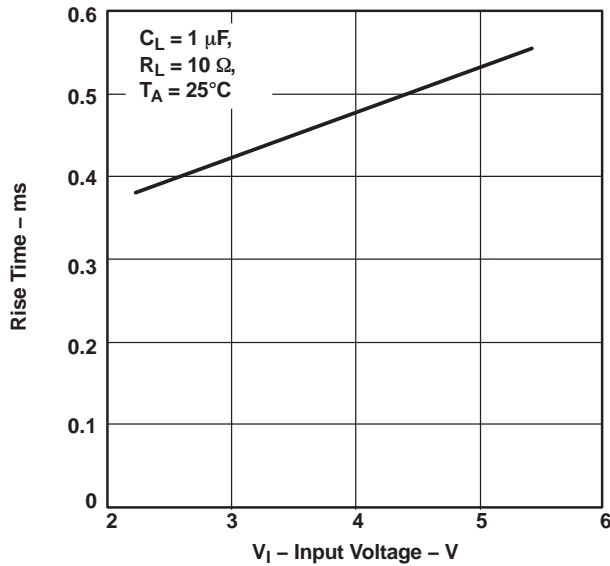

Figure 13.

FALL TIME  
vs  
INPUT VOLTAGE

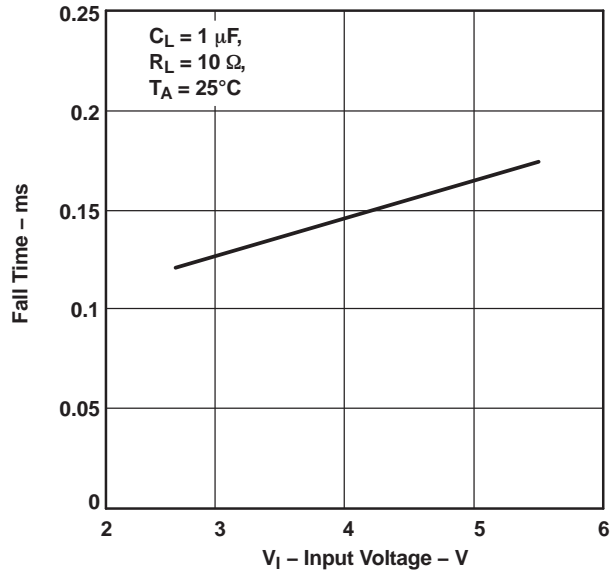

Figure 14.

**TYPICAL CHARACTERISTICS (continued)**

**SUPPLY CURRENT, OUTPUT ENABLED**  
vs  
**JUNCTION TEMPERATURE**

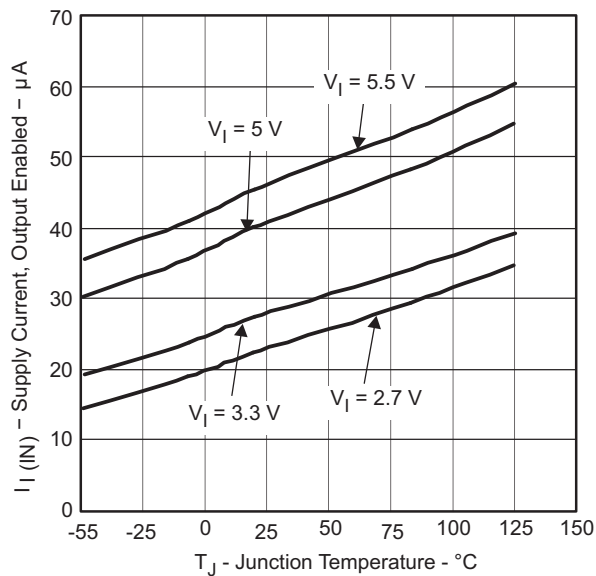

Figure 15.

**SUPPLY CURRENT, OUTPUT DISABLED**  
vs  
**JUNCTION TEMPERATURE**

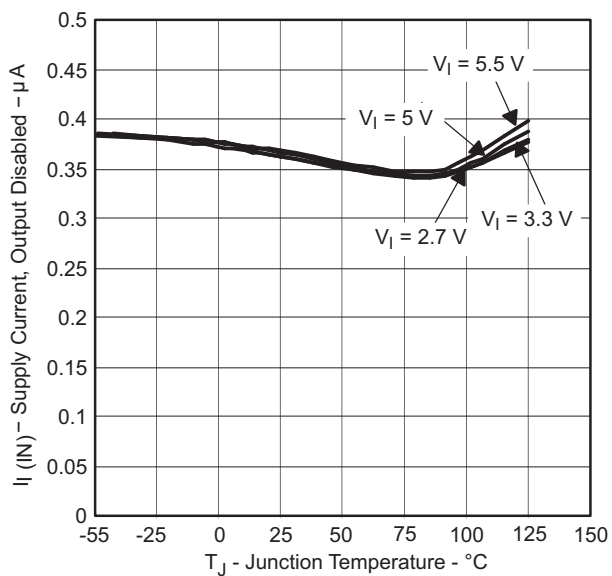

Figure 16.

**STATIC DRAIN-SOURCE ON-STATE RESISTANCE**  
vs  
**JUNCTION TEMPERATURE**

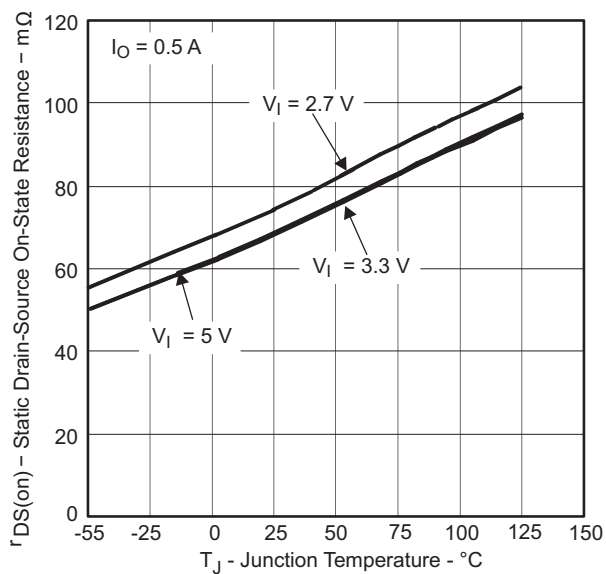

Figure 17.

**SHORT-CIRCUIT OUTPUT CURRENT**  
vs  
**JUNCTION TEMPERATURE**

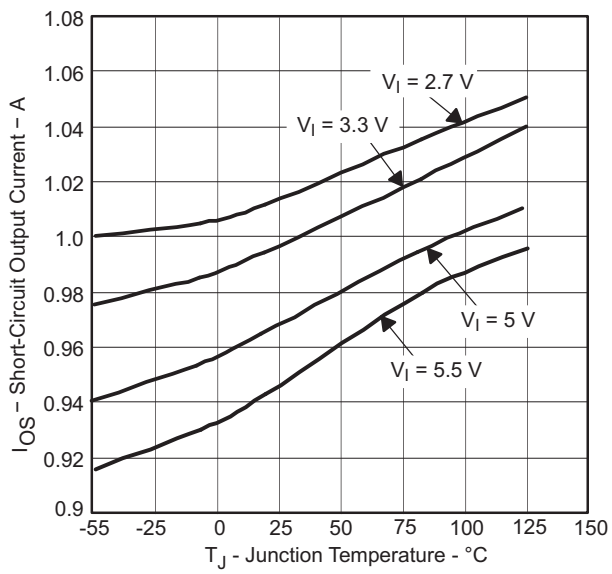

Figure 18.

**TYPICAL CHARACTERISTICS (continued)**

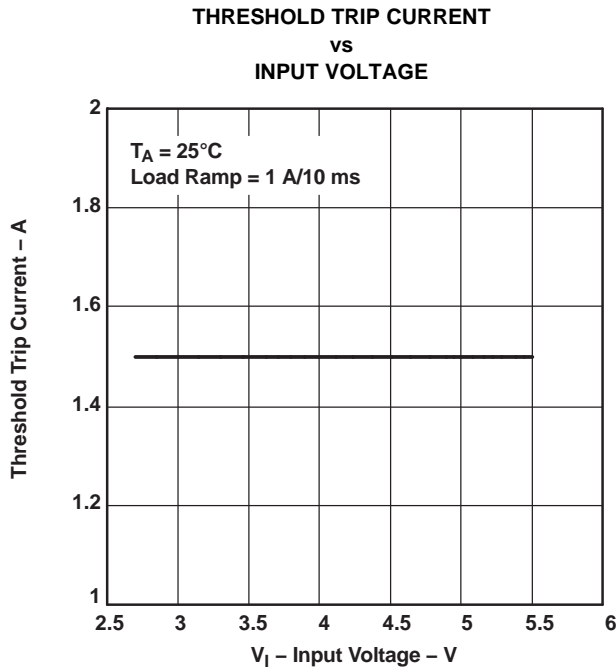

Figure 19.

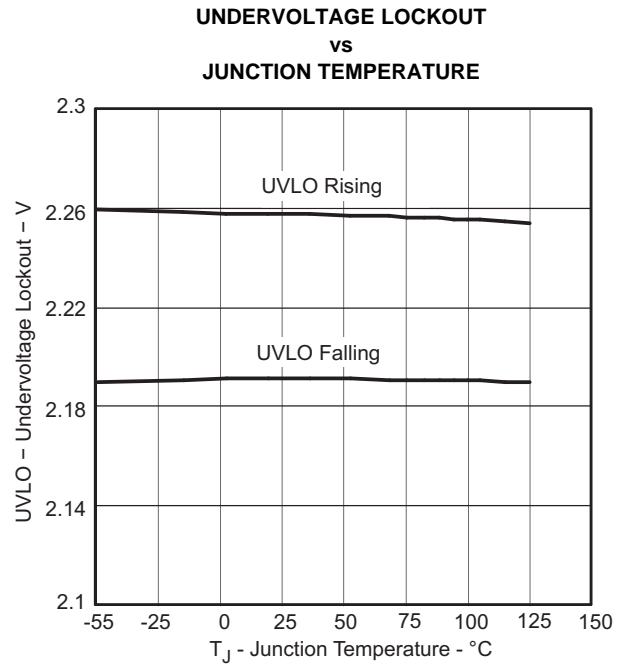

Figure 20.

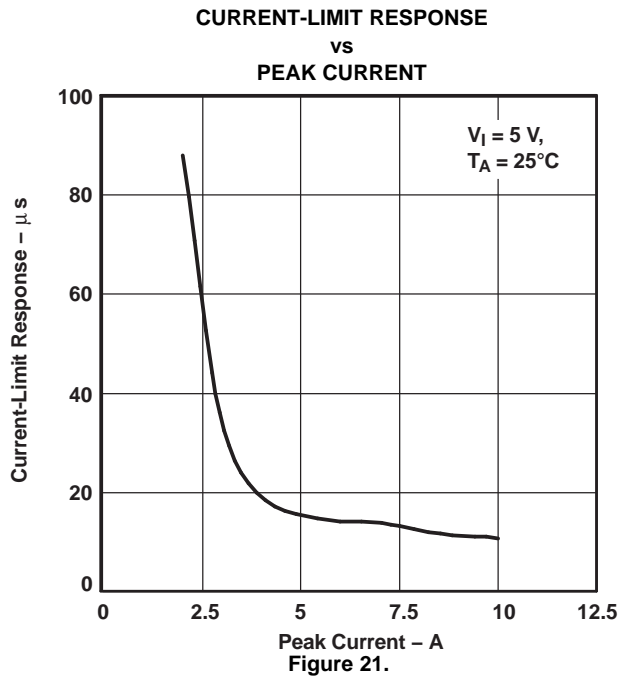
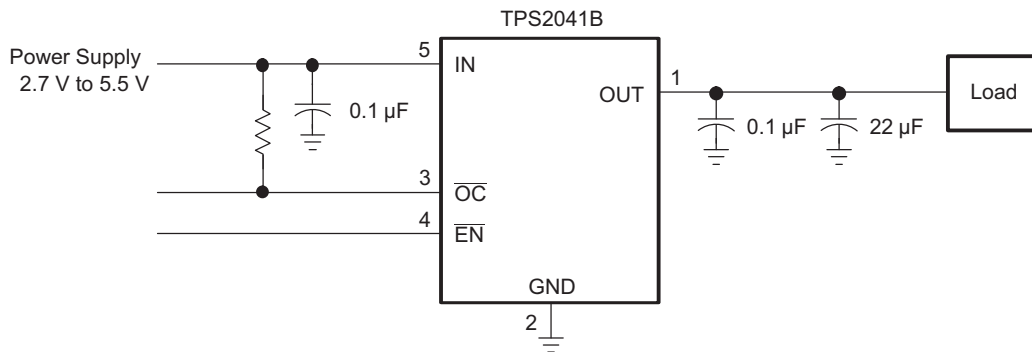

Figure 21.

## APPLICATION INFORMATION

### Power-Supply Considerations



**Figure 22. Typical Application**

A 0.01- $\mu\text{F}$  to 0.1- $\mu\text{F}$  ceramic bypass capacitor between IN and GND, close to the device, is recommended. Placing a high-value electrolytic capacitor on the output pin(s) is recommended when the output load is heavy. This precaution reduces power-supply transients that may cause ringing on the input. Additionally, bypassing the output with a 0.01- $\mu\text{F}$  to 0.1- $\mu\text{F}$  ceramic capacitor improves the immunity of the device to short-circuit transients.

### Overcurrent

A sense FET is employed to check for overcurrent conditions. Unlike current-sense resistors, sense FETs do not increase the series resistance of the current path. When an overcurrent condition is detected, the device maintains a constant output current and reduces the output voltage accordingly. Complete shutdown occurs only if the fault is present long enough to activate thermal limiting.

Three possible overload conditions can occur. In the first condition, the output has been shorted before the device is enabled or before  $V_{I(IN)}$  has been applied (see [Figure 15](#)). The TPS2041B senses the short and immediately switches into a constant-current output.

In the second condition, a short or an overload occurs while the device is enabled. At the instant the overload occurs, high currents may flow for a short period of time before the current-limit circuit can react. After the current-limit circuit has tripped (reached the overcurrent trip threshold), the device switches into constant-current mode.

In the third condition, the load has been gradually increased beyond the recommended operating current. The current is permitted to rise until the current-limit threshold is reached or until the thermal limit of the device is exceeded (see [Figure 16](#)). The TPS2041B is capable of delivering current up to the current-limit threshold without damaging the device. Once the threshold has been reached, the device switches into its constant-current mode.

### $\overline{\text{OC}}$ Response

The  $\overline{\text{OC}}$  open-drain output is asserted (active low) when an overcurrent or overtemperature shutdown condition is encountered after a 10-ms deglitch timeout. The output remains asserted until the overcurrent or overtemperature condition is removed. Connecting a heavy capacitive load to an enabled device can cause a momentary overcurrent condition; however, no false reporting on  $\overline{\text{OC}}$  occurs due to the 10-ms deglitch circuit. The TPS2041B is designed to eliminate false overcurrent reporting. The internal overcurrent deglitch eliminates the need for external components to remove unwanted pulses.  $\overline{\text{OC}}$  is not deglitched when the switch is turned off due to an overtemperature shutdown.

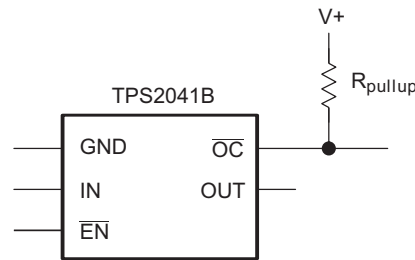

**Figure 23. Typical Circuit for the  $\overline{OC}$  Pin**

## Power Dissipation and Junction Temperature

The low on-resistance on the N-channel MOSFET allows the small surface-mount packages to pass large currents. The thermal resistances of these packages are high compared to those of power packages; it is good design practice to check power dissipation and junction temperature. Begin by determining the  $r_{DS(on)}$  of the N-channel MOSFET relative to the input voltage and operating temperature. As an initial estimate, use the highest operating ambient temperature of interest and read  $r_{DS(on)}$  from [Figure 17](#). Using this value, the power dissipation per switch can be calculated by:

$$P_D = r_{DS(on)} \times I^2$$

Multiply this number by the number of switches being used. This step renders the total power dissipation from the N-channel MOSFETs.

Finally, calculate the junction temperature:

$$T_J = P_D \times R_{\theta JA} + T_A$$

Where:

$T_A$  = Ambient temperature ( $^{\circ}\text{C}$ )

$R_{\theta JA}$  = Thermal resistance

$P_D$  = Total power dissipation based on number of switches being used.

Compare the calculated junction temperature with the initial estimate. If they do not agree within a few degrees, repeat the calculation, using the calculated value as the new estimate. Two or three iterations are generally sufficient to get a reasonable answer.

## Thermal Protection

Thermal protection prevents damage to the IC when heavy-overload or short-circuit faults are present for extended periods of time. The TPS2041B implements a thermal sensing to monitor the operating junction temperature of the power distribution switch. In an overcurrent or short-circuit condition, the junction temperature rises due to excessive power dissipation. Once the die temperature rises to approximately  $140^{\circ}\text{C}$  due to overcurrent conditions, the internal thermal sense circuitry turns the power switch off, thus preventing the power switch from damage. Hysteresis is built into the thermal sense circuit, and after the device has cooled approximately  $10^{\circ}\text{C}$ , the switch turns back on. The switch continues to cycle in this manner until the load fault or input power is removed. The  $\overline{OC}$  open-drain output is asserted (active low) when an overtemperature shutdown or overcurrent occurs.

## Undervoltage Lockout (UVLO)

The UVLO ensures that the power switch is in the off state at power up. Whenever the input voltage falls below approximately 2 V, the power switch is quickly turned off. This facilitates the design of hot-insertion systems where it is not possible to turn off the power switch before input power is removed. The UVLO also keeps the switch from being turned on until the power supply has reached at least 2 V, even if the switch is enabled. On reinsertion, the power switch is turned on, with a controlled rise time to reduce EMI and voltage overshoots.

## Universal Serial Bus (USB) Applications

The universal serial bus (USB) interface is a 12-Mb/s, or 1.5-Mb/s, multiplexed serial bus designed for low-to-medium bandwidth PC peripherals (e.g., keyboards, printers, scanners, and mice). The four-wire USB interface is conceived for dynamic attach-detach (hot plug-unplug) of peripherals. Two lines are provided for differential data, and two lines are provided for 5-V power distribution.

USB data is a 3.3-V level signal, but power is distributed at 5 V to allow for voltage drops in cases where power is distributed through more than one hub across long cables. Each function must provide its own regulated 3.3 V from the 5-V input or its own internal power supply.

The USB specification defines the following five classes of devices, each differentiated by power-consumption requirements:

- Hosts/self-powered hubs (SPHs)
- Bus-powered hubs (BPHs)
- Low-power bus-powered functions
- High-power bus-powered functions
- Self-powered functions

Self-powered and bus-powered hubs distribute data and power to downstream functions. The TPS2041B can provide power-distribution solutions to many of these classes of devices.

### Hosts/Self-Powered Hubs and Bus-Powered Hubs

Hosts and self-powered hubs have a local power supply that powers the embedded functions and the downstream ports (see Figure 24). This power supply must provide from 5.25 V to 4.75 V to the board side of the downstream connection under full-load and no-load conditions. Hosts and SPHs are required to have current-limit protection and must report overcurrent conditions to the USB controller. Typical SPHs are desktop PCs, monitors, printers, and stand-alone hubs.

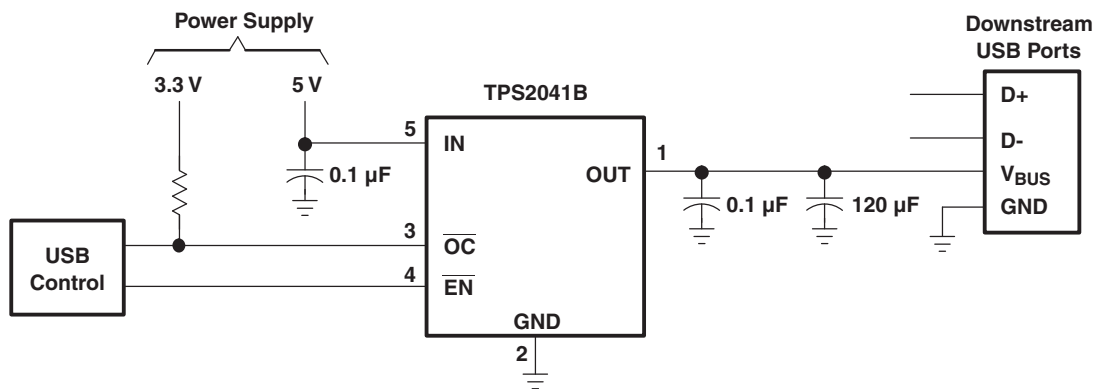
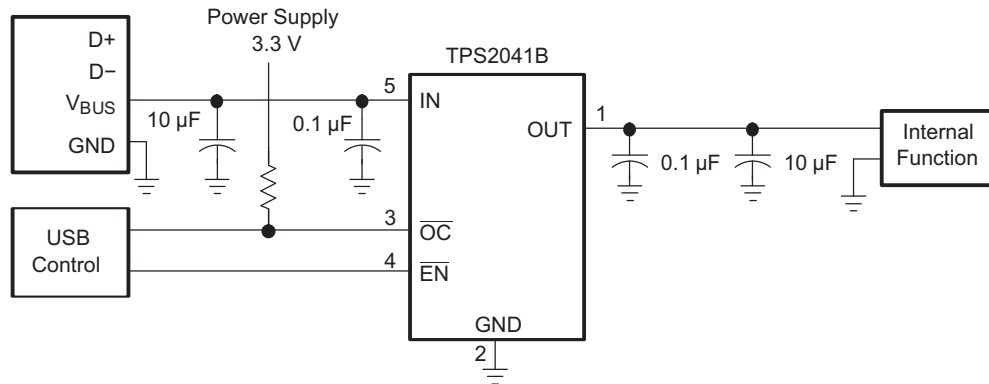

Figure 24. Typical One-Port USB Host/Self-Powered Hub

Bus-powered hubs obtain all power from upstream ports and often contain an embedded function. The hubs are required to power up with less than one unit load. The BPH usually has one embedded function, and power is always available to the controller of the hub. If the embedded function and hub require more than 100 mA on power up, the power to the embedded function may need to be kept off until enumeration is completed. This can be accomplished by removing power or by shutting off the clock to the embedded function. Power switching the embedded function is not necessary if the aggregate power draw for the function and controller is less than one unit load. The total current drawn by the bus-powered device is the sum of the current to the controller, the embedded function, and the downstream ports, and it is limited to 500 mA from an upstream port.

## Low-Power and High-Power Bus-Powered Functions

Both low-power and high-power bus-powered functions obtain all power from upstream ports; low-power functions always draw less than 100 mA; high-power functions must draw less than 100 mA at power up and can draw up to 500 mA after enumeration. If the load of the function is more than the parallel combination of 44  $\Omega$  and 10  $\mu\text{F}$  at power up, the device must implement inrush current limiting (see [Figure 25](#)).



**Figure 25. High-Power Bus-Powered Function**

## USB Power-Distribution Requirements

USB can be implemented in several ways, and, regardless of the type of USB device being developed, several power-distribution features must be implemented.

- Hosts/self-powered hubs must:
  - Current-limit downstream ports
  - Report overcurrent conditions on USB  $V_{\text{BUS}}$
- Bus-powered hubs must:
  - Enable/disable power to downstream ports
  - Power up at <100 mA
  - Limit inrush current (<44  $\Omega$  and 10  $\mu\text{F}$ )
- Functions must:
  - Limit inrush currents
  - Power up at <100 mA

The feature set of the TPS2041B allows them to meet each of these requirements. The integrated current-limiting and overcurrent reporting is required by hosts and self-powered hubs. The logic-level enable and controlled rise times meet the need of both input and output ports on bus-powered hubs, as well as the input ports for bus-powered functions (see [Figure 26](#)).

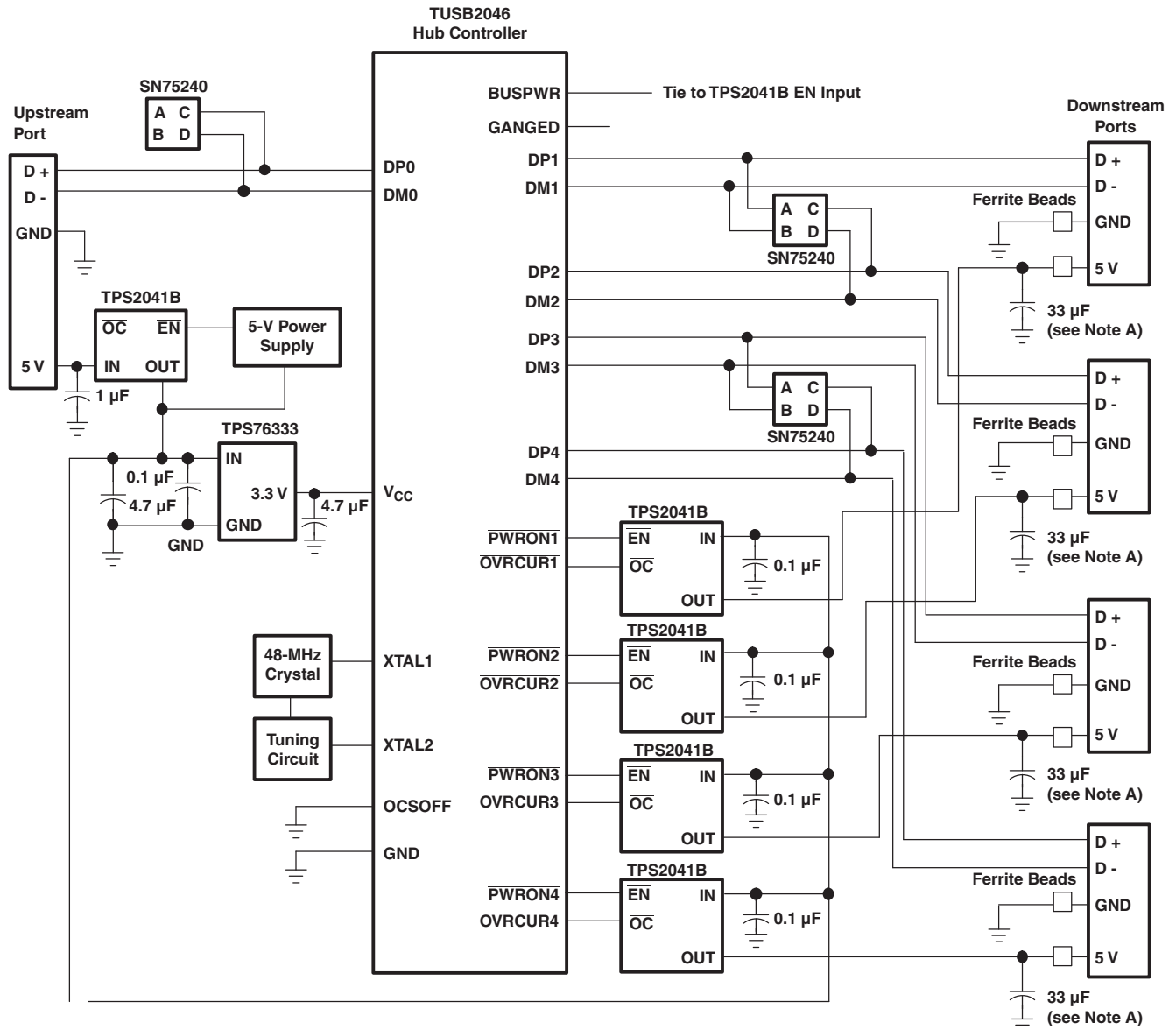

A. USB rev 1.1 requires 120 µF per hub.

**Figure 26. Hybrid Self-Powered/Bus-Powered Hub Implementation**

## Generic Hot-Plug Applications

In many applications, it may be necessary to remove modules or PC boards while the main unit is still operating. These are considered hot-plug applications. Such implementations require the control of current surges seen by the main power supply and the card being inserted. The most effective way to control these surges is to limit and slowly ramp the current and voltage being applied to the card, similar to the way in which a power supply normally turns on. Due to the controlled rise times and fall times of the TPS2041B, these devices can be used to provide a softer startup to devices being hot-plugged into a powered system. The UVLO feature of the TPS2041B also ensures that the switch is off after the card has been removed, and that the switch is off during the next insertion. The UVLO feature ensures a soft start with a controlled rise time for every insertion of the card or module.

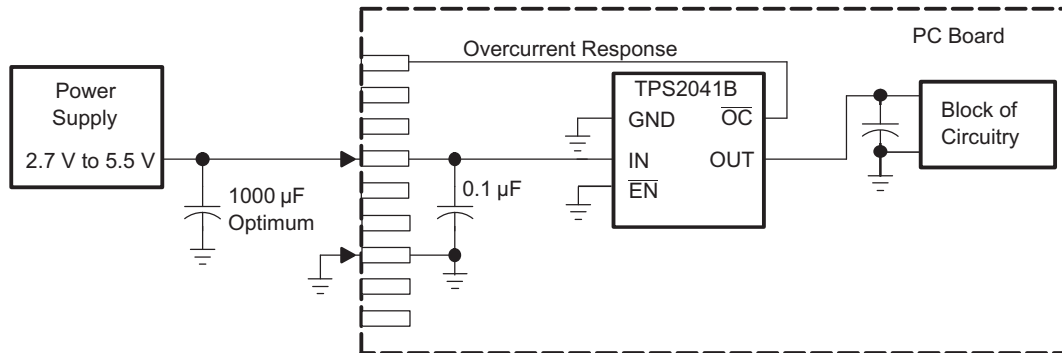

**Figure 27. Typical Hot-Plug Implementation**

By placing the TPS2041B between the  $V_{CC}$  input and the rest of the circuitry, the input power reaches these devices first after insertion. The typical rise time of the switch is approximately 1 ms, providing a slow voltage ramp at the output of the device. This implementation controls system surge currents and provides a hot-plugging mechanism for any device.

## DETAILED DESCRIPTION

### Power Switch

The power switch is an N-channel MOSFET with a low on-state resistance. Configured as a high-side switch, the power switch prevents current flow from OUT to IN and IN to OUT when disabled. The power switch supplies a minimum current of 500 mA.

### Charge Pump

An internal charge pump supplies power to the driver circuit and provides the necessary voltage to pull the gate of the MOSFET above the source. The charge pump operates from input voltages as low as 2.7 V and requires little supply current.

### Driver

The driver controls the gate voltage of the power switch. To limit large current surges and reduce the associated electromagnetic interference (EMI) produced, the driver incorporates circuitry that controls the rise times and fall times of the output voltage.

### Enable ( $\overline{EN}$ )

The logic enable pin disables the power switch and the bias for the charge pump, driver, and other circuitry to reduce the supply current. The supply current is reduced to less than 1  $\mu$ A or 2  $\mu$ A when a logic high is present on  $\overline{EN}$ . A logic zero input on  $\overline{EN}$  restores bias to the drive and control circuits and turns the switch on. The enable input is compatible with both TTL and CMOS logic levels.

## Overcurrent ( $\overline{OC}$ )

The  $\overline{OC}$  open-drain output is asserted (active low) when an overcurrent or overtemperature condition is encountered. The output remains asserted until the overcurrent or overtemperature condition is removed. A 10-ms deglitch circuit prevents the  $\overline{OC}$  signal from oscillation or false triggering. If an overtemperature shutdown occurs, the  $\overline{OC}$  is asserted instantaneously.

## Current Sense

A sense FET monitors the current supplied to the load. The sense FET measures current more efficiently than conventional resistance methods. When an overload or short circuit is encountered, the current-sense circuitry sends a control signal to the driver. The driver in turn reduces the gate voltage and drives the power FET into its saturation region, which switches the output into a constant-current mode and holds the current constant while varying the voltage on the load.

## Thermal Sense

The TPS2041B implements a thermal sensing to monitor the operating temperature of the power distribution switch. In an overcurrent or short-circuit condition, the junction temperature rises. When the die temperature rises to approximately 140°C due to overcurrent conditions, the internal thermal sense circuitry turns off the switch, thus preventing the device from damage. Hysteresis is built into the thermal sense, and after the device has cooled approximately 10 degrees, the switch turns back on. The switch continues to cycle off and on until the fault is removed. The open-drain false reporting output ( $\overline{OC}$ ) is asserted (active low) when an overtemperature shutdown or overcurrent occurs.

## Undervoltage Lockout (UVLO)

A voltage sense circuit monitors the input voltage. When the input voltage is below approximately 2 V, a control signal turns off the power switch.

**PACKAGING INFORMATION**

Orderable Device	Status (1)	Package Type	Package Drawing	Pins	Package Qty	Eco Plan (2)	Lead/Ball Finish	MSL Peak Temp (3)	Op Temp (°C)	Top-Side Markings (4)	Samples
TPS2041BMDVBVTEP	ACTIVE	SOT-23	DBV	5	250	Green (RoHS & no Sb/Br)	CU NIPDAU	Level-1-260C-UNLIM	-55 to 125	PXAM	<a href="#">Samples</a>
V62/11620-01XE	ACTIVE	SOT-23	DBV	5	250	Green (RoHS & no Sb/Br)	CU NIPDAU	Level-1-260C-UNLIM	-55 to 125	PXAM	<a href="#">Samples</a>

(1) The marketing status values are defined as follows:

**ACTIVE:** Product device recommended for new designs.

**LIFEBUY:** TI has announced that the device will be discontinued, and a lifetime-buy period is in effect.

**NRND:** Not recommended for new designs. Device is in production to support existing customers, but TI does not recommend using this part in a new design.

**PREVIEW:** Device has been announced but is not in production. Samples may or may not be available.

**OBSOLETE:** TI has discontinued the production of the device.

(2) Eco Plan - The planned eco-friendly classification: Pb-Free (RoHS), Pb-Free (RoHS Exempt), or Green (RoHS & no Sb/Br) - please check <http://www.ti.com/productcontent> for the latest availability information and additional product content details.

**TBD:** The Pb-Free/Green conversion plan has not been defined.

**Pb-Free (RoHS):** TI's terms "Lead-Free" or "Pb-Free" mean semiconductor products that are compatible with the current RoHS requirements for all 6 substances, including the requirement that lead not exceed 0.1% by weight in homogeneous materials. Where designed to be soldered at high temperatures, TI Pb-Free products are suitable for use in specified lead-free processes.

**Pb-Free (RoHS Exempt):** This component has a RoHS exemption for either 1) lead-based flip-chip solder bumps used between the die and package, or 2) lead-based die adhesive used between the die and leadframe. The component is otherwise considered Pb-Free (RoHS compatible) as defined above.

**Green (RoHS & no Sb/Br):** TI defines "Green" to mean Pb-Free (RoHS compatible), and free of Bromine (Br) and Antimony (Sb) based flame retardants (Br or Sb do not exceed 0.1% by weight in homogeneous material)

(3) MSL, Peak Temp. -- The Moisture Sensitivity Level rating according to the JEDEC industry standard classifications, and peak solder temperature.

(4) Multiple Top-Side Markings will be inside parentheses. Only one Top-Side Marking contained in parentheses and separated by a "~" will appear on a device. If a line is indented then it is a continuation of the previous line and the two combined represent the entire Top-Side Marking for that device.

**Important Information and Disclaimer:** The information provided on this page represents TI's knowledge and belief as of the date that it is provided. TI bases its knowledge and belief on information provided by third parties, and makes no representation or warranty as to the accuracy of such information. Efforts are underway to better integrate information from third parties. TI has taken and continues to take reasonable steps to provide representative and accurate information but may not have conducted destructive testing or chemical analysis on incoming materials and chemicals. TI and TI suppliers consider certain information to be proprietary, and thus CAS numbers and other limited information may not be available for release.

In no event shall TI's liability arising out of such information exceed the total purchase price of the TI part(s) at issue in this document sold by TI to Customer on an annual basis.

**OTHER QUALIFIED VERSIONS OF TPS2041B-EP :**

- Catalog: [TPS2041B](#)
- Automotive: [TPS2041B-Q1](#)

NOTE: Qualified Version Definitions:

- Catalog - TI's standard catalog product
- Automotive - Q100 devices qualified for high-reliability automotive applications targeting zero defects

## TAPE AND REEL INFORMATION



### QUADRANT ASSIGNMENTS FOR PIN 1 ORIENTATION IN TAPE



\*All dimensions are nominal

Device	Package Type	Package Drawing	Pins	SPQ	Reel Diameter (mm)	Reel Width W1 (mm)	A0 (mm)	B0 (mm)	K0 (mm)	P1 (mm)	W (mm)	Pin1 Quadrant
TPS2041BMDBVTEP	SOT-23	DBV	5	250	178.0	9.0	3.3	3.2	1.4	4.0	8.0	Q3

**TAPE AND REEL BOX DIMENSIONS**



\*All dimensions are nominal

Device	Package Type	Package Drawing	Pins	SPQ	Length (mm)	Width (mm)	Height (mm)
TPS2041BMDBVTEP	SOT-23	DBV	5	250	180.0	180.0	18.0



DBV (R-PDSO-G5)

PLASTIC SMALL OUTLINE



- NOTES:
- A. All linear dimensions are in millimeters.
  - B. This drawing is subject to change without notice.
  - C. Customers should place a note on the circuit board fabrication drawing not to alter the center solder mask defined pad.
  - D. Publication IPC-7351 is recommended for alternate designs.
  - E. Laser cutting apertures with trapezoidal walls and also rounding corners will offer better paste release. Customers should contact their board assembly site for stencil design recommendations. Example stencil design based on a 50% volumetric metal load solder paste. Refer to IPC-7525 for other stencil recommendations.

## IMPORTANT NOTICE

Texas Instruments Incorporated and its subsidiaries (TI) reserve the right to make corrections, enhancements, improvements and other changes to its semiconductor products and services per JESD46, latest issue, and to discontinue any product or service per JESD48, latest issue. Buyers should obtain the latest relevant information before placing orders and should verify that such information is current and complete. All semiconductor products (also referred to herein as "components") are sold subject to TI's terms and conditions of sale supplied at the time of order acknowledgment.

TI warrants performance of its components to the specifications applicable at the time of sale, in accordance with the warranty in TI's terms and conditions of sale of semiconductor products. Testing and other quality control techniques are used to the extent TI deems necessary to support this warranty. Except where mandated by applicable law, testing of all parameters of each component is not necessarily performed.

TI assumes no liability for applications assistance or the design of Buyers' products. Buyers are responsible for their products and applications using TI components. To minimize the risks associated with Buyers' products and applications, Buyers should provide adequate design and operating safeguards.

TI does not warrant or represent that any license, either express or implied, is granted under any patent right, copyright, mask work right, or other intellectual property right relating to any combination, machine, or process in which TI components or services are used. Information published by TI regarding third-party products or services does not constitute a license to use such products or services or a warranty or endorsement thereof. Use of such information may require a license from a third party under the patents or other intellectual property of the third party, or a license from TI under the patents or other intellectual property of TI.

Reproduction of significant portions of TI information in TI data books or data sheets is permissible only if reproduction is without alteration and is accompanied by all associated warranties, conditions, limitations, and notices. TI is not responsible or liable for such altered documentation. Information of third parties may be subject to additional restrictions.

Resale of TI components or services with statements different from or beyond the parameters stated by TI for that component or service voids all express and any implied warranties for the associated TI component or service and is an unfair and deceptive business practice. TI is not responsible or liable for any such statements.

Buyer acknowledges and agrees that it is solely responsible for compliance with all legal, regulatory and safety-related requirements concerning its products, and any use of TI components in its applications, notwithstanding any applications-related information or support that may be provided by TI. Buyer represents and agrees that it has all the necessary expertise to create and implement safeguards which anticipate dangerous consequences of failures, monitor failures and their consequences, lessen the likelihood of failures that might cause harm and take appropriate remedial actions. Buyer will fully indemnify TI and its representatives against any damages arising out of the use of any TI components in safety-critical applications.

In some cases, TI components may be promoted specifically to facilitate safety-related applications. With such components, TI's goal is to help enable customers to design and create their own end-product solutions that meet applicable functional safety standards and requirements. Nonetheless, such components are subject to these terms.

No TI components are authorized for use in FDA Class III (or similar life-critical medical equipment) unless authorized officers of the parties have executed a special agreement specifically governing such use.

Only those TI components which TI has specifically designated as military grade or "enhanced plastic" are designed and intended for use in military/aerospace applications or environments. Buyer acknowledges and agrees that any military or aerospace use of TI components which have **not** been so designated is solely at the Buyer's risk, and that Buyer is solely responsible for compliance with all legal and regulatory requirements in connection with such use.

TI has specifically designated certain components as meeting ISO/TS16949 requirements, mainly for automotive use. In any case of use of non-designated products, TI will not be responsible for any failure to meet ISO/TS16949.

### Products

Audio	<a href="http://www.ti.com/audio">www.ti.com/audio</a>
Amplifiers	<a href="http://amplifier.ti.com">amplifier.ti.com</a>
Data Converters	<a href="http://dataconverter.ti.com">dataconverter.ti.com</a>
DLP® Products	<a href="http://www.dlp.com">www.dlp.com</a>
DSP	<a href="http://dsp.ti.com">dsp.ti.com</a>
Clocks and Timers	<a href="http://www.ti.com/clocks">www.ti.com/clocks</a>
Interface	<a href="http://interface.ti.com">interface.ti.com</a>
Logic	<a href="http://logic.ti.com">logic.ti.com</a>
Power Mgmt	<a href="http://power.ti.com">power.ti.com</a>
Microcontrollers	<a href="http://microcontroller.ti.com">microcontroller.ti.com</a>
RFID	<a href="http://www.ti-rfid.com">www.ti-rfid.com</a>
OMAP Applications Processors	<a href="http://www.ti.com/omap">www.ti.com/omap</a>
Wireless Connectivity	<a href="http://www.ti.com/wirelessconnectivity">www.ti.com/wirelessconnectivity</a>

### Applications

Automotive and Transportation	<a href="http://www.ti.com/automotive">www.ti.com/automotive</a>
Communications and Telecom	<a href="http://www.ti.com/communications">www.ti.com/communications</a>
Computers and Peripherals	<a href="http://www.ti.com/computers">www.ti.com/computers</a>
Consumer Electronics	<a href="http://www.ti.com/consumer-apps">www.ti.com/consumer-apps</a>
Energy and Lighting	<a href="http://www.ti.com/energy">www.ti.com/energy</a>
Industrial	<a href="http://www.ti.com/industrial">www.ti.com/industrial</a>
Medical	<a href="http://www.ti.com/medical">www.ti.com/medical</a>
Security	<a href="http://www.ti.com/security">www.ti.com/security</a>
Space, Avionics and Defense	<a href="http://www.ti.com/space-avionics-defense">www.ti.com/space-avionics-defense</a>
Video and Imaging	<a href="http://www.ti.com/video">www.ti.com/video</a>

### TI E2E Community

[e2e.ti.com](http://e2e.ti.com)