



ULTRA-SMALL SUPPLY VOLTAGE SUPERVISORS

Check for Samples: [TPS3800-xx](#), [TPS3801-xx](#), [TPS3802-xx](#)

FEATURES

- Small, 5-Pin SC-70 (SOT-323) Package
- Supply Current of 9 μ A
- Power-On Reset Generator With Fixed Delay Time
 - TPS3800 = 100 ms
 - TPS3801 = 200 ms
 - TPS3802 = 400 ms
- Precision Supply Voltage Monitor 1.8 V, 2.5 V, 2.7 V, 3 V, 3.3 V, 5 V, and Adjustable
- Manual Reset Input (Except TPS3801-01)
- Temperature Range: -40°C to $+85^{\circ}\text{C}$

APPLICATIONS

- Applications Using DSPs, Microcontrollers, or Microprocessors
- Wireless Communication Systems
- Portable/Battery-Powered Equipment
- Programmable Controls
- Intelligent Instruments
- Industrial Equipment
- Notebook/Desktop Computers
- Automotive Systems

DESCRIPTION

The TPS380x family of supervisory circuits monitor supply voltages to provide circuit initialization and timing supervision, primarily for DSPs and other processor-based systems.

These devices assert a push-pull $\overline{\text{RESET}}$ signal when the SENSE (adjustable version) or V_{DD} (fixed version) drops below a preset threshold. The $\overline{\text{RESET}}$ output remains asserted for the factory programmed delay time after the SENSE or V_{DD} return above its threshold.

The TPS380x devices, except the TPS3801-01, incorporate a manual reset input ($\overline{\text{MR}}$). A low level at $\overline{\text{MR}}$ causes $\overline{\text{RESET}}$ to become active.

The TPS380x uses a precision reference to achieve an overall threshold accuracy of 2%–2.5%. These devices are available in a 5-pin SC-70 package, which is only about half the size of a 5-pin SOT-23 package.

The TPS380x devices are fully specified over a temperature range of -40°C to $+85^{\circ}\text{C}$.

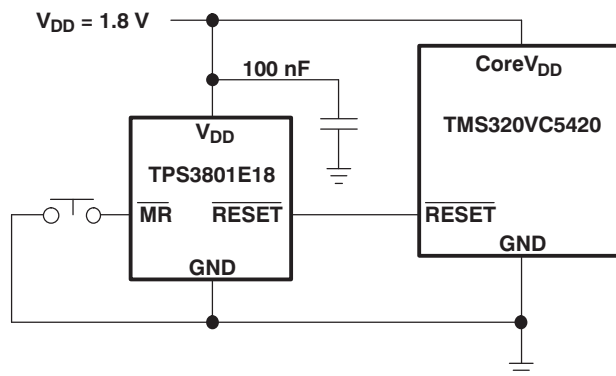
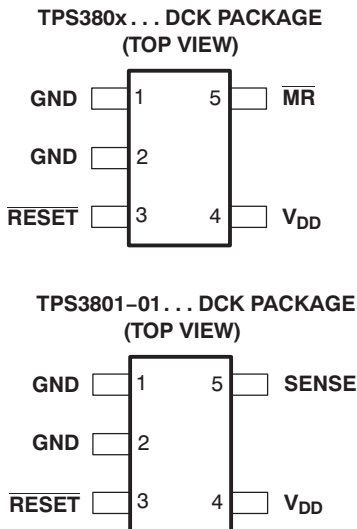



These devices have limited built-in ESD protection. The leads should be shorted together or the device placed in conductive foam during storage or handling to prevent electrostatic damage to the MOS gates.

AVAILABLE OPTIONS⁽¹⁾

T _A	DEVICE NAME	THRESHOLD VOLTAGE	TYP DELAY TIME	MARKING
-40°C to 85°C	TPS3801-01DCK	Adjustable (V _{ref} = 1.14 V)	200 ms	ARF
	TPS3801E18DCK	1.71 V	200 ms	ARE
	TPS3801J25DCK	2.25 V	200 ms	NJA
	TPS3800G27DCK	2.5 V	95 ms	ARI
	TPS3801L30DCK	2.64 V	200 ms	NPA
	TPS3801K33DCK	2.93 V	200 ms	NWA
	TPS3802L30DCK	2.64 V	380 ms	ASA
	TPS3802K33DCK	2.93 V	380 ms	ARK
	TPS3801T50DCK	4.00 V	25 ms	AVI
	TPS3801I50DCK	4.55 V	200 ms	NSA

(1) For the most current package and ordering information, see the Package Option Addendum at the end of this data sheet, or refer to our web site at www.ti.com.

ABSOLUTE MAXIMUM RATINGS^{(1) (2)}

Over operating free-air temperature range (unless otherwise noted).

	UNIT
Supply voltage, V _{DD}	7 V
SENSE	-0.3 V to 5 V
All other pins	-0.3 V to 7 V
\overline{MR}	-0.3 V to V _{DD} + 0.3 V
\overline{RESET}	-0.3 V to V _{DD} + 0.3 V
Maximum low-output current, I _{OL}	5 mA
Maximum high-output current, I _{OH}	-5 mA
Input-clamp current, I _{IK} (V _I < 0 or V _I > V _{DD})	±20 mA
Output-clamp current, I _{OK} (V _O < 0 or V _O > V _{DD})	±20 mA
Operating junction temperature range, T _J ⁽³⁾	-40°C to +85°C
Storage temperature range, T _{stg}	-65°C to +150°C

(1) Stresses beyond those listed under *absolute maximum ratings* may cause permanent damage to the device. These are stress ratings only, and functional operation of the device at these or any other conditions beyond those indicated under *recommended operating conditions* is not implied. Exposure to absolute-maximum-rated conditions for extended periods may affect device reliability.

(2) All voltage values are with respect to GND. For reliable operation, the device should not be operated at 7 V for more than t = 1000h continuously.

(3) Due to the low dissipation power of this device, it is assumed that T_J = T_A.

RECOMMENDED OPERATING CONDITIONS

	MIN	MAX	UNIT	
Supply voltage, V _{DD}	TPS3801J25, TPS3801L30, TPS3801K33, TPS3801I50, TPS3801T50	2	6	V
	All other devices	1.6	4	
SENSE	0	See ⁽¹⁾	V	
Input voltage, V _I	0	V _{DD} + 0.3	V	
High-level input voltage, V _{IH}	0.7 × V _{DD}	V _{DD} + 0.3	V	
Low-level input voltage, V _{IL}		0.3 × V _{DD}	V	
Input transition rise and fall rate at \overline{MR} , Δt/ΔV		100	ns/V	
Pull-up resistor value, \overline{RESET}	V _{Pull-up} 50μA		Ω	
Operating free-air temperature range, T _A	-40	+85	°C	

(1) Maximum = V_{DD} + 0.3 or 4.5 V, whichever is greater.

ELECTRICAL CHARACTERISTICS

Over -40°C to $+85^{\circ}\text{C}$ free-air temperature range (unless otherwise noted).

PARAMETER		TEST CONDITIONS	TPS3800-xx, TPS3801-xx, TPS3802-xx			UNIT	
			MIN	TYP	MAX		
V_{OH}	High-level output voltage ($\overline{\text{RESET}}$)	$V_{DD} = 1.6\text{ V to }6\text{ V}$, $I_{OH} = -500\ \mu\text{A}$	$V_{DD} - 0.2$			V	
		$V_{DD} = 3.3\text{ V}$, $I_{OH} = -2\text{ mA}$	$V_{DD} - 0.4$				
		$V_{DD} = 6\text{ V}$, $I_{OH} = -4\text{ mA}$ ⁽¹⁾	$V_{DD} - 0.4$				
V_{OL}	Low-level output voltage ($\overline{\text{RESET}}$)	$V_{DD} = 1.6\text{ V to }6\text{ V}$, $I_{OL} = 500\ \mu\text{A}$	0.2			V	
		$V_{DD} = 3.3\text{ V}$, $I_{OL} = 2\text{ mA}$	0.4				
		$V_{DD} = 6\text{ V}$, $I_{OL} = 4\text{ mA}$ ⁽¹⁾	0.4				
Power-up reset voltage ⁽²⁾		$V_{DD} \geq 1.1\text{ V}$, $I_{OL} = 50\ \mu\text{A}$	0.2			V	
V_{IT-}	Negative-going input threshold voltage ⁽³⁾	$T_A = -40^{\circ}\text{C to }85^{\circ}\text{C}$	TPS380x-01	1.117	1.14	1.163	V
			TPS380xE18	1.67	1.71	1.75	
			TPS380xJ25	2.2	2.25	2.3	
			TPS380xG27	2.45	2.5	2.55	
			TPS380xL30	2.58	2.64	2.7	
			TPS380xK33	2.87	2.93	2.99	
			TPS380xI50	4.45	4.55	4.65	
			TPS380xT50	3.92	4	4.08	
V_{hys}	Threshold hysteresis		TPS380x-01	15		mV	
			TPS380xx18	25			
			TPS380xx25	30			
			TPS380xx27	35			
			TPS380xx30	35			
			TPS380xx33	40			
			TPS380xx50	60			
I_{IH}	High-level input current ($\overline{\text{MR}}$)	$\overline{\text{MR}} = 0.7 \times V_{DD}$, $V_{DD} = 6\text{ V}$	-40	-60	-100	μA	
I_{IL}	Low-level input current ($\overline{\text{MR}}$)	$\overline{\text{MR}} = 0\text{ V}$, $V_{DD} = 6\text{ V}$	-130	-200	-340	μA	
I_i	Input current (SENSE)		-25		25	nA	
I_{DD}	Supply current	TPS3801J25, TPS3801L30, TPS3801K33, TPS3801I50, TPS3801T50	$V_{DD} = 2\text{ V}$, $\overline{\text{MR}}$ and output unconnected	9	12	μA	
			$V_{DD} = 6\text{ V}$, $\overline{\text{MR}}$ and output unconnected	20	25		
		TPS3801-01	$V_{DD} = 1.6\text{ V}$, SENSE = 0 V to V_{DD} , output unconnected	7	10		
			$V_{DD} = 4\text{ V}$, SENSE = 0 V to V_{DD} , output unconnected	9	12		
		TPS3801E18, TPS3800G27, TPS3802K33, TPS3802L30	$V_{DD} = 1.6\text{ V}$, $\overline{\text{MR}}$ and output unconnected	8	11		
			$V_{DD} = 4\text{ V}$, $\overline{\text{MR}}$ and output unconnected	13	18		
C_i	Input capacitance	$V_i = 0\text{ V to }V_{DD}$	5		pF		

(1) Only valid for the TPS3801J25, TPS3801L30, TPS3801K33, TPS3801I50, and TPS3801T50.

(2) The lowest supply voltage at which $\overline{\text{RESET}}$ becomes active. t_r , $V_{DD} \geq 15\ \mu\text{s/V}$.

(3) To ensure the best stability of the threshold voltage, a bypass capacitor (0.1- μF ceramic) should be placed near the supply terminals.

TIMING REQUIREMENTS

at $R_L = 1\text{ M}\Omega$, $C_L = 50\text{ pF}$, $T_A = +25^\circ\text{C}$

PARAMETER		TEST CONDITIONS	MIN	TYP	MAX	UNIT	
t_w	Pulse width	at SENSE	$V_{DD} = 1.6\text{ V}$, $V_{IH} = 1.1 \times V_{IT-}$, $V_{IL} = 0.9 \times V_{IT-}$			1	μs
		at V_{DD}	$V_{DD} = V_{IT-} + 0.2\text{ V}$, $V_{DD} = V_{IT-} - 0.2\text{ V}$			3	
		at $\overline{\text{MR}}$	$V_{DD} \geq V_{IT-} + 0.2\text{ V}$, $V_{IL} = 0.3 \times V_{DD}$, $V_{IH} = 0.7 \times V_{DD}$			100	ns

SWITCHING CHARACTERISTICS

at $R_L = 1\text{ M}\Omega$, $C_L = 50\text{ pF}$, $T_A = +25^\circ\text{C}$

PARAMETER		TEST CONDITIONS	MIN	TYP	MAX	UNIT	
t_d	$\overline{\text{RESET}}$ recovery delay time	TPS3801T50	15	25	35	ms	
		TPS3800	60	95	140		
		TPS3801	120	200	280		
		TPS3802	240	380	560		
t_{PHL}	Propagation (delay) time, high-to-low-level output	$\overline{\text{MR}}$ to $\overline{\text{RESET}}$ delay	$V_{DD} \geq V_{IT-} + 0.2\text{ V}$, $V_{IL} = 0.3 \times V_{DD}$, $V_{IH} = 0.7 \times V_{DD}$			15	ns
		V_{DD} to $\overline{\text{RESET}}$ delay	$V_{IL} = V_{IT-} - 0.2\text{ V}$, $V_{IH} = V_{IT-} + 0.2\text{ V}$			1	μs
		SENSE to $\overline{\text{RESET}}$	$V_{IL} = V_{IT-} - 0.2\text{ V}$, $V_{IH} = V_{IT-} + 0.2\text{ V}$			1	μs

TIMING DIAGRAM

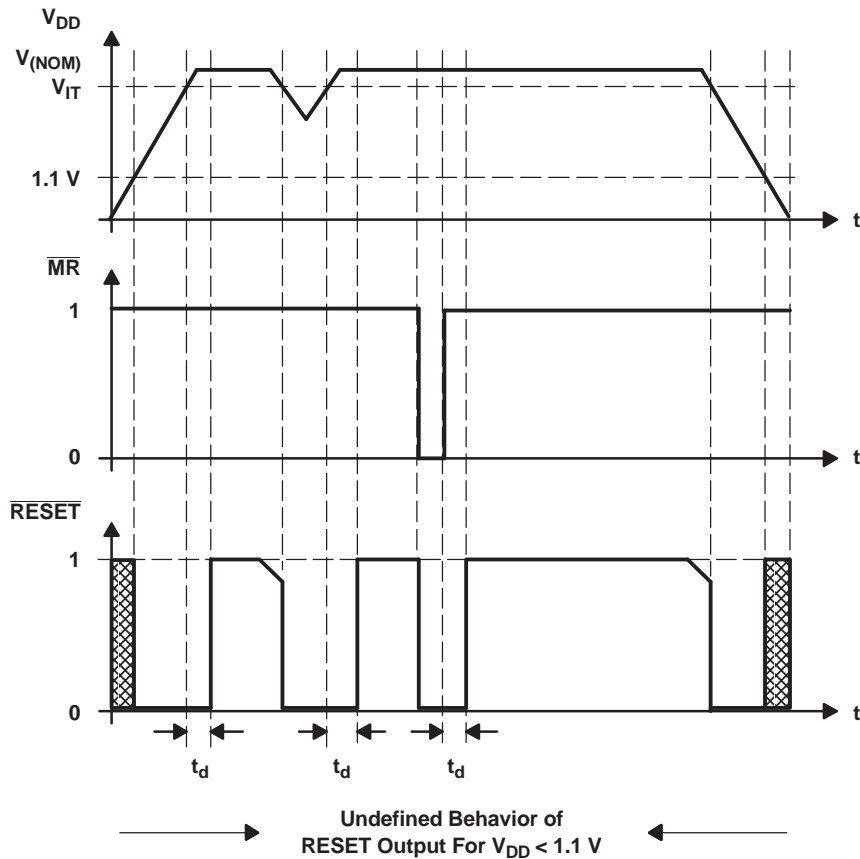

NOTE: $\overline{\text{RESET}}$ should not be forced high during the power-up sequence (until $V_{DD} > 1.1\text{ V}$).

FUNCTIONAL BLOCK DIAGRAMS

FUNCTION/TRUTH TABLE, TPS380x

MR	$V_{DD} > V_{IT}$	RESET
L	0	L
L	1	L
H	0	L
H	1	H

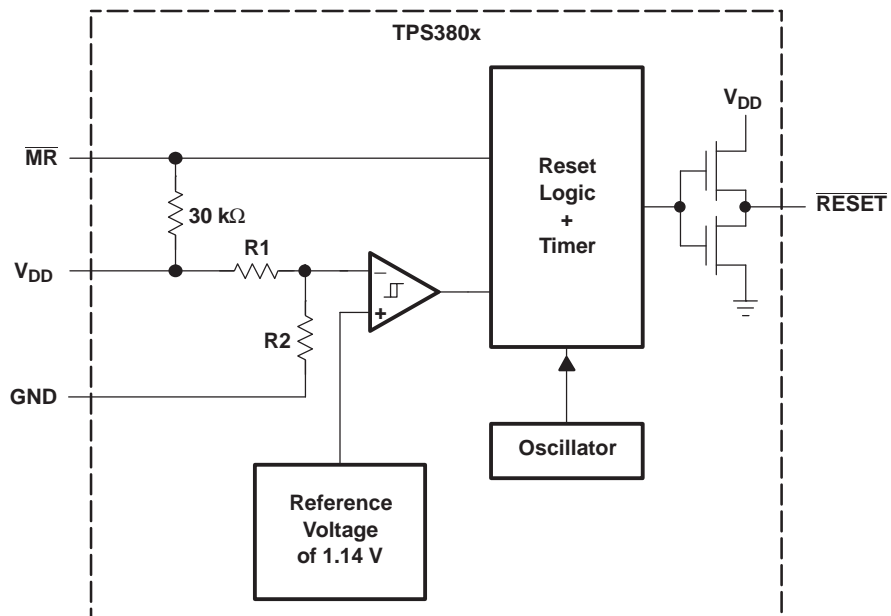

Figure 1.

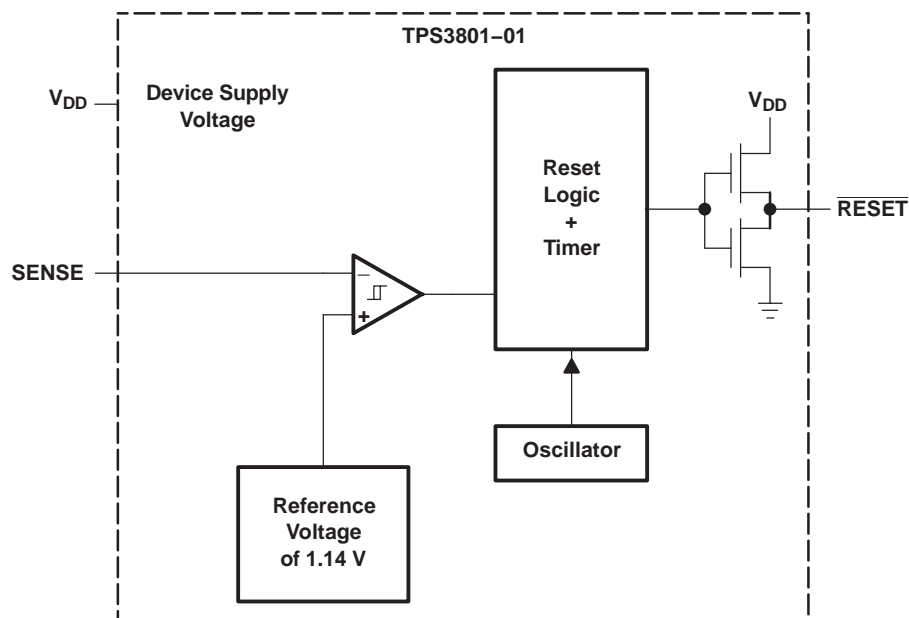

Figure 2.

TYPICAL CHARACTERISTICS

LOW-LEVEL OUTPUT VOLTAGE
 vs
 LOW-LEVEL OUTPUT CURRENT

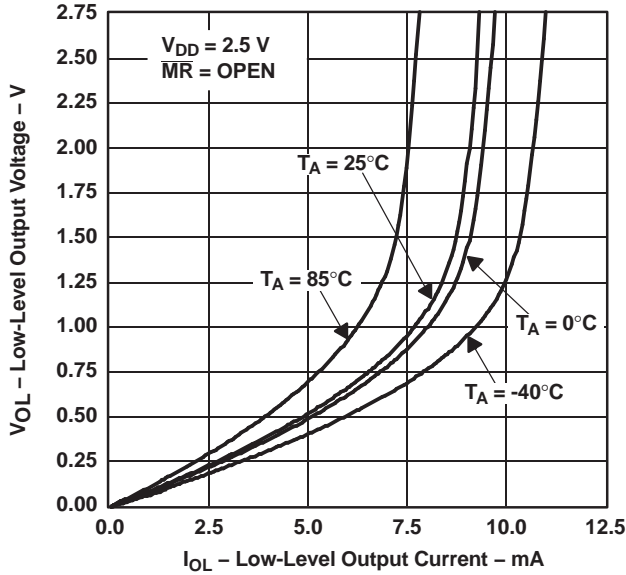

Figure 3.

SUPPLY CURRENT
 vs
 SUPPLY VOLTAGE

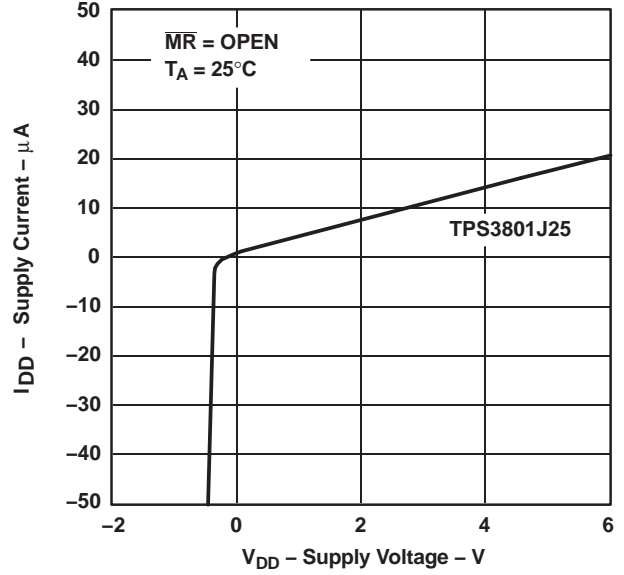

Figure 4.

HIGH-LEVEL OUTPUT VOLTAGE
 vs
 HIGH-LEVEL OUTPUT CURRENT

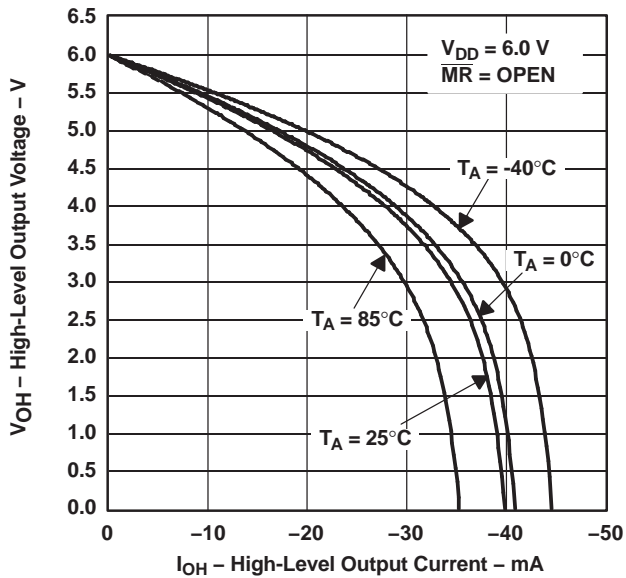

Figure 5.

HIGH-LEVEL OUTPUT VOLTAGE
 vs
 HIGH-LEVEL OUTPUT CURRENT

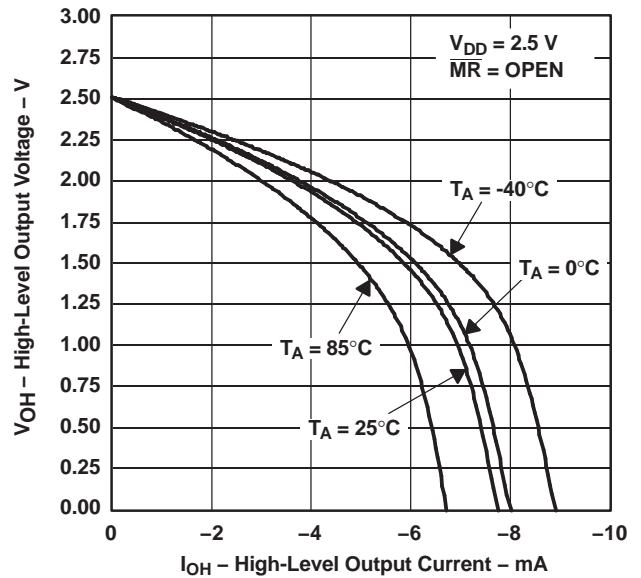
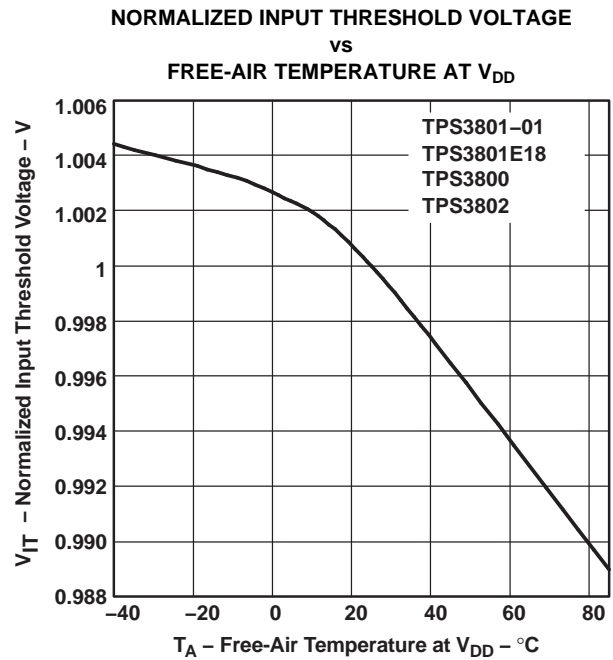
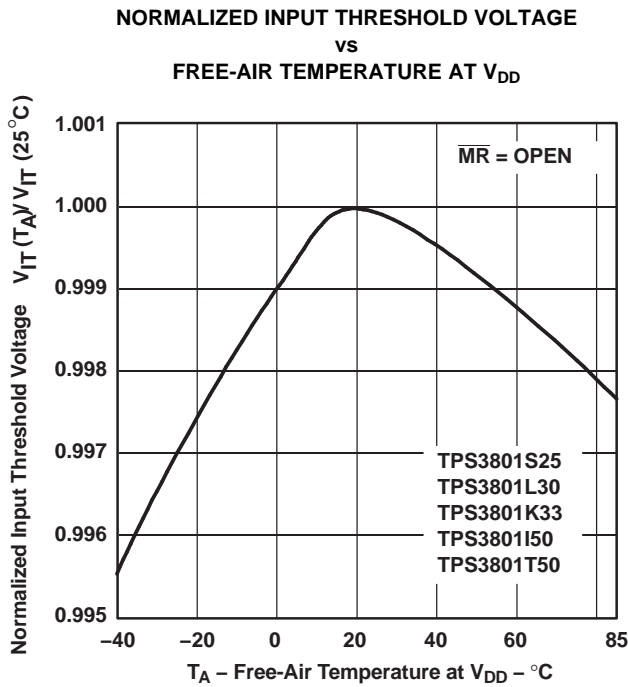
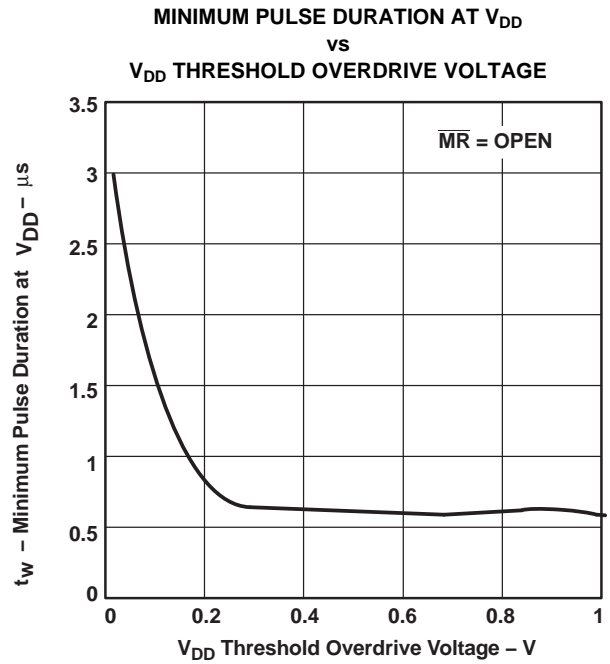
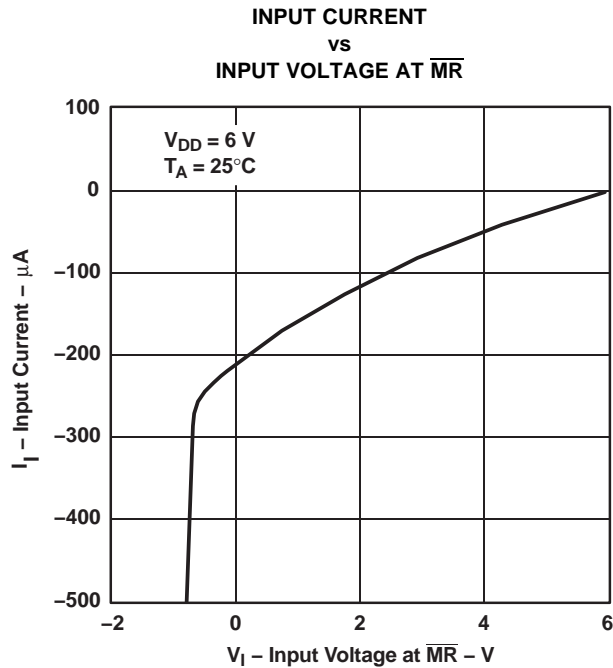

Figure 6.

TYPICAL CHARACTERISTICS (continued)



Changes from Revision D (December 2006) to Revision E

Page

-
- Added Pull-up resistor value, $\overline{\text{RESET}}$ to the Recommended Operating Conditions Table [2](#)
-

PACKAGE OPTION ADDENDUM





7-Nov-2014

PACKAGING INFORMATION

Orderable Device	Status (1)	Package Type	Package Drawing	Pins	Package Qty	Eco Plan (2)	Lead/Ball Finish (6)	MSL Peak Temp (3)	Op Temp (°C)	Device Marking (4/5)	Samples
TPS3800G27DCKR	ACTIVE	SC70	DCK	5	3000	Green (RoHS & no Sb/Br)	CU NIPDAU	Level-1-260C-UNLIM	-40 to 85	ARI	Samples
TPS3800G27DCKRG4	ACTIVE	SC70	DCK	5	3000	Green (RoHS & no Sb/Br)	CU NIPDAU	Level-1-260C-UNLIM	-40 to 85	ARI	Samples
TPS3801-01DCKR	ACTIVE	SC70	DCK	5	3000	Green (RoHS & no Sb/Br)	CU NIPDAU	Level-1-260C-UNLIM	-40 to 85	ARF	Samples
TPS3801-01DCKRG4	ACTIVE	SC70	DCK	5	3000	Green (RoHS & no Sb/Br)	CU NIPDAU	Level-1-260C-UNLIM	-40 to 85	ARF	Samples
TPS3801E18DCKR	ACTIVE	SC70	DCK	5	3000	Green (RoHS & no Sb/Br)	CU NIPDAU	Level-1-260C-UNLIM	-40 to 85	ARE	Samples
TPS3801E18DCKRG4	ACTIVE	SC70	DCK	5		TBD	Call TI	Call TI	-40 to 85		Samples
TPS3801I50DCKR	ACTIVE	SC70	DCK	5	3000	Green (RoHS & no Sb/Br)	CU NIPDAU	Level-1-260C-UNLIM	-40 to 85	NSA	Samples
TPS3801I50DCKRG4	ACTIVE	SC70	DCK	5	3000	Green (RoHS & no Sb/Br)	CU NIPDAU	Level-1-260C-UNLIM	-40 to 85	NSA	Samples
TPS3801J25DCKR	ACTIVE	SC70	DCK	5	3000	Green (RoHS & no Sb/Br)	CU NIPDAU	Level-1-260C-UNLIM	-40 to 85	NJA	Samples
TPS3801J25DCKRG4	ACTIVE	SC70	DCK	5	3000	Green (RoHS & no Sb/Br)	CU NIPDAU	Level-1-260C-UNLIM	-40 to 85	NJA	Samples
TPS3801K33DCKR	ACTIVE	SC70	DCK	5	3000	Green (RoHS & no Sb/Br)	CU NIPDAU	Level-1-260C-UNLIM	-40 to 85	NWA	Samples
TPS3801K33DCKRG4	ACTIVE	SC70	DCK	5	3000	Green (RoHS & no Sb/Br)	CU NIPDAU	Level-1-260C-UNLIM	-40 to 85	NWA	Samples
TPS3801L30DCKR	ACTIVE	SC70	DCK	5	3000	Green (RoHS & no Sb/Br)	CU NIPDAU	Level-1-260C-UNLIM	-40 to 85	NPA	Samples
TPS3801L30DCKRG4	ACTIVE	SC70	DCK	5	3000	Green (RoHS & no Sb/Br)	CU NIPDAU	Level-1-260C-UNLIM	-40 to 85	NPA	Samples
TPS3801T50DCKR	ACTIVE	SC70	DCK	5	3000	Green (RoHS & no Sb/Br)	CU NIPDAU	Level-1-260C-UNLIM	-40 to 85	AVI	Samples
TPS3801T50DCKRG4	ACTIVE	SC70	DCK	5	3000	Green (RoHS & no Sb/Br)	CU NIPDAU	Level-1-260C-UNLIM	-40 to 85	AVI	Samples
TPS3801T50DCKT	OBSOLETE	SC70	DCK	5		TBD	Call TI	Call TI	-40 to 85		

PACKAGE OPTION ADDENDUM

7-Nov-2014

Orderable Device	Status (1)	Package Type	Package Drawing	Pins	Package Qty	Eco Plan (2)	Lead/Ball Finish (6)	MSL Peak Temp (3)	Op Temp (°C)	Device Marking (4/5)	Samples
TPS3802K33DCKR	ACTIVE	SC70	DCK	5	3000	Green (RoHS & no Sb/Br)	CU NIPDAU	Level-1-260C-UNLIM	-40 to 85	ARK	
TPS3802K33DCKRG4	ACTIVE	SC70	DCK	5		TBD	Call TI	Call TI	-40 to 85		
TPS3802L30DCKR	ACTIVE	SC70	DCK	5	3000	Green (RoHS & no Sb/Br)	CU NIPDAU	Level-1-260C-UNLIM	-40 to 85	ASA	
TPS3802L30DCKRG4	ACTIVE	SC70	DCK	5	3000	Green (RoHS & no Sb/Br)	CU NIPDAU	Level-1-260C-UNLIM	-40 to 85	ASA	

(1) The marketing status values are defined as follows:

ACTIVE: Product device recommended for new designs.

LIFEBUY: TI has announced that the device will be discontinued, and a lifetime-buy period is in effect.

NRND: Not recommended for new designs. Device is in production to support existing customers, but TI does not recommend using this part in a new design.

PREVIEW: Device has been announced but is not in production. Samples may or may not be available.

OBSOLETE: TI has discontinued the production of the device.

(2) Eco Plan - The planned eco-friendly classification: Pb-Free (RoHS), Pb-Free (RoHS Exempt), or Green (RoHS & no Sb/Br) - please check <http://www.ti.com/productcontent> for the latest availability information and additional product content details.

TBD: The Pb-Free/Green conversion plan has not been defined.

Pb-Free (RoHS): TI's terms "Lead-Free" or "Pb-Free" mean semiconductor products that are compatible with the current RoHS requirements for all 6 substances, including the requirement that lead not exceed 0.1% by weight in homogeneous materials. Where designed to be soldered at high temperatures, TI Pb-Free products are suitable for use in specified lead-free processes.

Pb-Free (RoHS Exempt): This component has a RoHS exemption for either 1) lead-based flip-chip solder bumps used between the die and package, or 2) lead-based die adhesive used between the die and leadframe. The component is otherwise considered Pb-Free (RoHS compatible) as defined above.

Green (RoHS & no Sb/Br): TI defines "Green" to mean Pb-Free (RoHS compatible), and free of Bromine (Br) and Antimony (Sb) based flame retardants (Br or Sb do not exceed 0.1% by weight in homogeneous material)

(3) MSL, Peak Temp. - The Moisture Sensitivity Level rating according to the JEDEC industry standard classifications, and peak solder temperature.

(4) There may be additional marking, which relates to the logo, the lot trace code information, or the environmental category on the device.

(5) Multiple Device Markings will be inside parentheses. Only one Device Marking contained in parentheses and separated by a "~" will appear on a device. If a line is indented then it is a continuation of the previous line and the two combined represent the entire Device Marking for that device.

(6) Lead/Ball Finish - Orderable Devices may have multiple material finish options. Finish options are separated by a vertical ruled line. Lead/Ball Finish values may wrap to two lines if the finish value exceeds the maximum column width.

Important Information and Disclaimer: The information provided on this page represents TI's knowledge and belief as of the date that it is provided. TI bases its knowledge and belief on information provided by third parties, and makes no representation or warranty as to the accuracy of such information. Efforts are underway to better integrate information from third parties. TI has taken and

7-Nov-2014

continues to take reasonable steps to provide representative and accurate information but may not have conducted destructive testing or chemical analysis on incoming materials and chemicals. TI and TI suppliers consider certain information to be proprietary, and thus CAS numbers and other limited information may not be available for release.

In no event shall TI's liability arising out of such information exceed the total purchase price of the TI part(s) at issue in this document sold by TI to Customer on an annual basis.

TAPE AND REEL INFORMATION

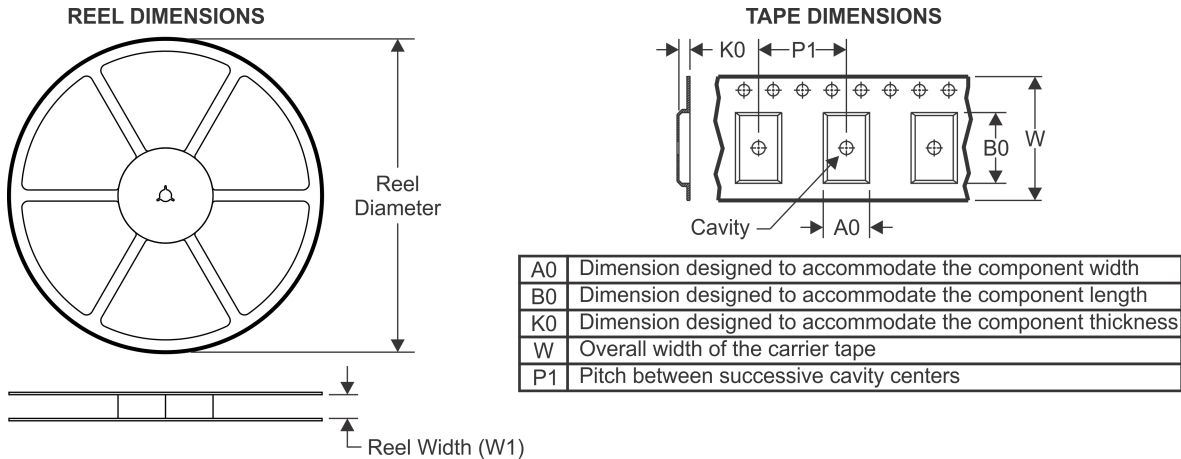

QUADRANT ASSIGNMENTS FOR PIN 1 ORIENTATION IN TAPE

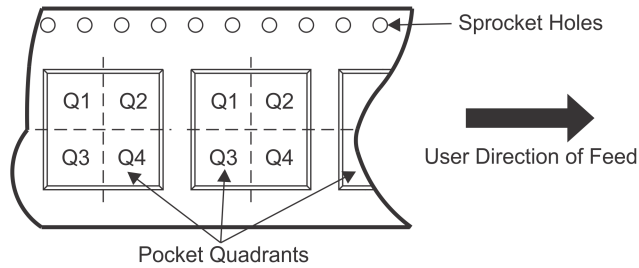

*All dimensions are nominal

Device	Package Type	Package Drawing	Pins	SPQ	Reel Diameter (mm)	Reel Width W1 (mm)	A0 (mm)	B0 (mm)	K0 (mm)	P1 (mm)	W (mm)	Pin1 Quadrant
TPS3800G27DCKR	SC70	DCK	5	3000	178.0	9.0	2.4	2.5	1.2	4.0	8.0	Q3
TPS3800G27DCKR	SC70	DCK	5	3000	180.0	8.4	2.41	2.41	1.2	4.0	8.0	Q3
TPS3801-01DCKR	SC70	DCK	5	3000	178.0	9.0	2.4	2.5	1.2	4.0	8.0	Q3
TPS3801-01DCKR	SC70	DCK	5	3000	180.0	8.4	2.41	2.41	1.2	4.0	8.0	Q3
TPS3801E18DCKR	SC70	DCK	5	3000	180.0	8.4	2.41	2.41	1.2	4.0	8.0	Q3
TPS3801E18DCKR	SC70	DCK	5	3000	178.0	9.0	2.4	2.5	1.2	4.0	8.0	Q3
TPS3801I50DCKR	SC70	DCK	5	3000	180.0	8.4	2.41	2.41	1.2	4.0	8.0	Q3
TPS3801J25DCKR	SC70	DCK	5	3000	180.0	8.4	2.41	2.41	1.2	4.0	8.0	Q3
TPS3801K33DCKR	SC70	DCK	5	3000	180.0	8.4	2.41	2.41	1.2	4.0	8.0	Q3
TPS3801K33DCKR	SC70	DCK	5	3000	178.0	9.0	2.4	2.5	1.2	4.0	8.0	Q3
TPS3801L30DCKR	SC70	DCK	5	3000	180.0	8.4	2.41	2.41	1.2	4.0	8.0	Q3
TPS3801T50DCKR	SC70	DCK	5	3000	178.0	9.0	2.4	2.5	1.2	4.0	8.0	Q3
TPS3801T50DCKR	SC70	DCK	5	3000	180.0	8.4	2.41	2.41	1.2	4.0	8.0	Q3
TPS3802K33DCKR	SC70	DCK	5	3000	178.0	9.0	2.4	2.5	1.2	4.0	8.0	Q3
TPS3802K33DCKR	SC70	DCK	5	3000	180.0	8.4	2.41	2.41	1.2	4.0	8.0	Q3
TPS3802L30DCKR	SC70	DCK	5	3000	178.0	9.0	2.4	2.5	1.2	4.0	8.0	Q3
TPS3802L30DCKR	SC70	DCK	5	3000	180.0	8.4	2.41	2.41	1.2	4.0	8.0	Q3

TAPE AND REEL BOX DIMENSIONS

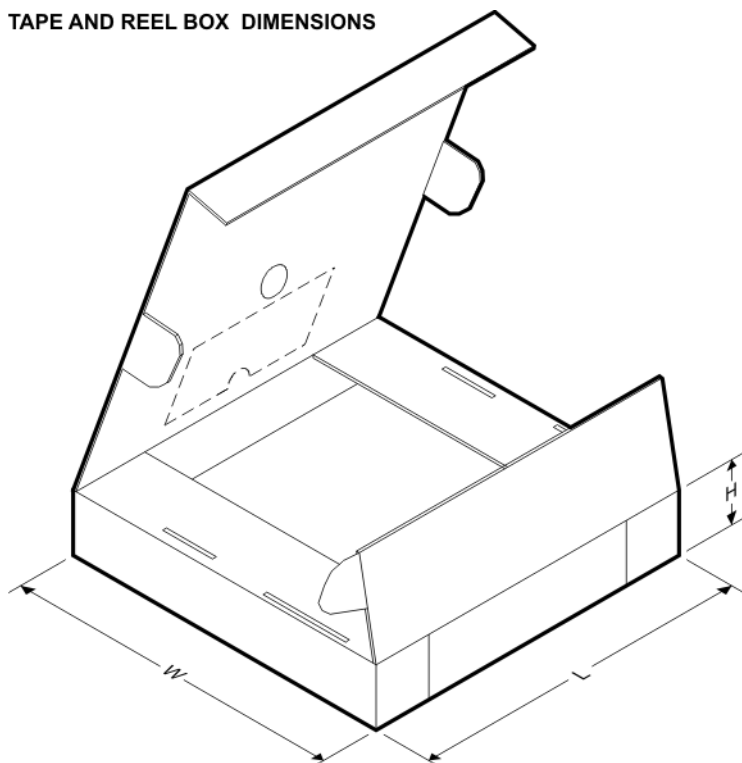

*All dimensions are nominal

Device	Package Type	Package Drawing	Pins	SPQ	Length (mm)	Width (mm)	Height (mm)
TPS3800G27DCKR	SC70	DCK	5	3000	180.0	180.0	18.0
TPS3800G27DCKR	SC70	DCK	5	3000	202.0	201.0	28.0
TPS3801-01DCKR	SC70	DCK	5	3000	180.0	180.0	18.0
TPS3801-01DCKR	SC70	DCK	5	3000	202.0	201.0	28.0
TPS3801E18DCKR	SC70	DCK	5	3000	202.0	201.0	28.0
TPS3801E18DCKR	SC70	DCK	5	3000	180.0	180.0	18.0
TPS3801I50DCKR	SC70	DCK	5	3000	202.0	201.0	28.0
TPS3801J25DCKR	SC70	DCK	5	3000	202.0	201.0	28.0
TPS3801K33DCKR	SC70	DCK	5	3000	202.0	201.0	28.0
TPS3801K33DCKR	SC70	DCK	5	3000	180.0	180.0	18.0
TPS3801L30DCKR	SC70	DCK	5	3000	202.0	201.0	28.0
TPS3801T50DCKR	SC70	DCK	5	3000	180.0	180.0	18.0
TPS3801T50DCKR	SC70	DCK	5	3000	202.0	201.0	28.0
TPS3802K33DCKR	SC70	DCK	5	3000	180.0	180.0	18.0
TPS3802K33DCKR	SC70	DCK	5	3000	202.0	201.0	28.0
TPS3802L30DCKR	SC70	DCK	5	3000	180.0	180.0	18.0
TPS3802L30DCKR	SC70	DCK	5	3000	202.0	201.0	28.0

DCK (R-PDSO-G5)

PLASTIC SMALL-OUTLINE PACKAGE

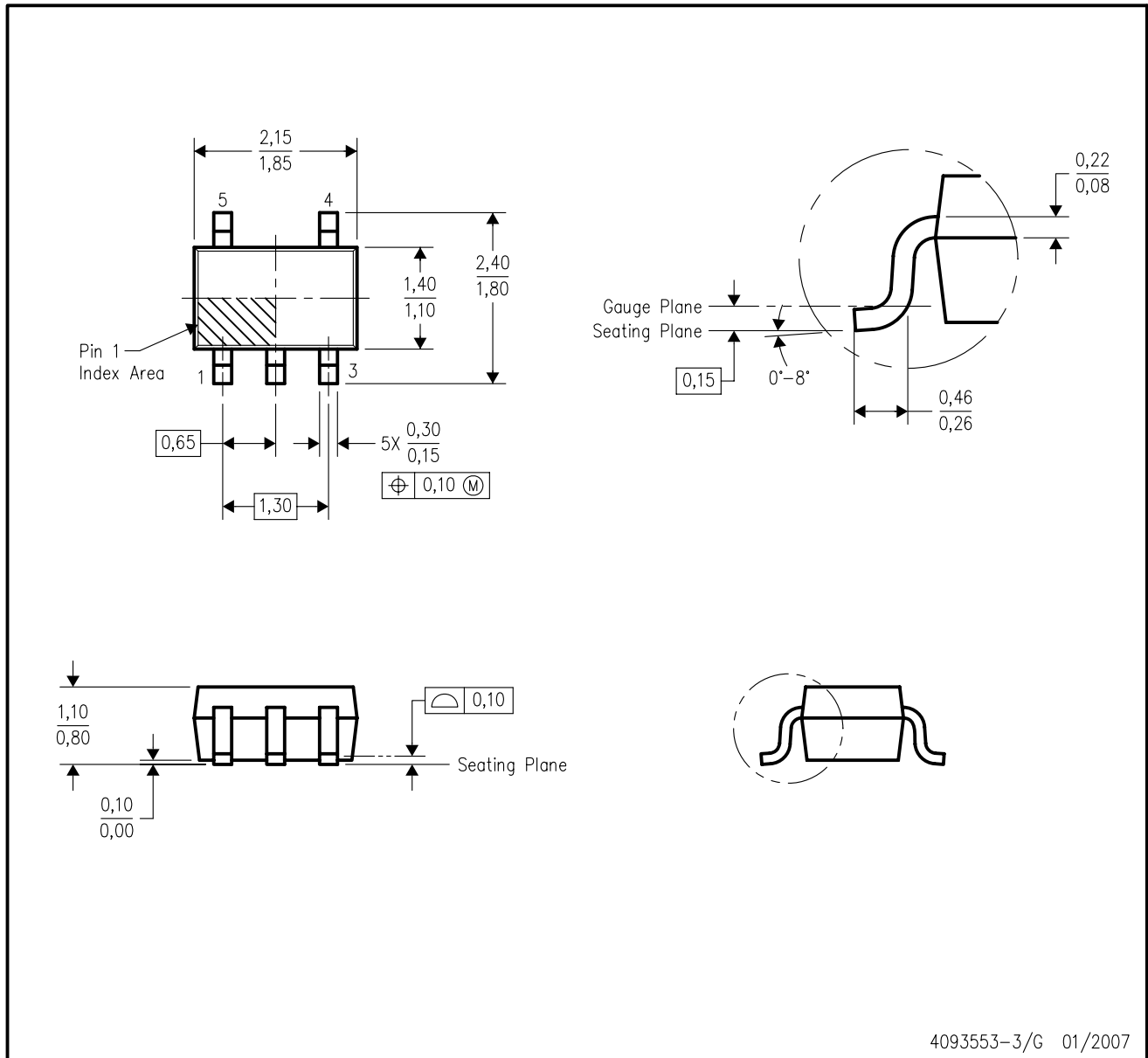

- NOTES:
- All linear dimensions are in millimeters.
 - This drawing is subject to change without notice.
 - Body dimensions do not include mold flash or protrusion. Mold flash and protrusion shall not exceed 0.15 per side.
 - Falls within JEDEC MO-203 variation AA.

DCK (R-PDSO-G5)

PLASTIC SMALL OUTLINE



- NOTES:
- A. All linear dimensions are in millimeters.
 - B. This drawing is subject to change without notice.
 - C. Customers should place a note on the circuit board fabrication drawing not to alter the center solder mask defined pad.
 - D. Publication IPC-7351 is recommended for alternate designs.
 - E. Laser cutting apertures with trapezoidal walls and also rounding corners will offer better paste release. Customers should contact their board assembly site for stencil design recommendations. Example stencil design based on a 50% volumetric metal load solder paste. Refer to IPC-7525 for other stencil recommendations.