

4.5-V TO 18-V INPUT 10-PIN SYNCHRONOUS BUCK CONTROLLER WITH POWER GOOD

 Check for Samples: [TPS40192](#), [TPS40193](#)

FEATURES

- Input Operating Voltage Range: 4.5 V to 18 V
- Up to 20-A Output Currents
- Supports Pre-Biased Outputs
- 0.5%, 591-mV Reference
- 600 kHz (TPS40192) and 300 kHz (TPS40193) Switching Frequencies
- Three Selectable Thermally Compensated Short-Circuit Protection Levels
- Hiccup Restart from Faults
- Internal 5-V Regulator
- High-Side and Low-Side FET $R_{DS(on)}$ Current Sensing
- 10-Pin 3 mm × 3 mm SON Package
- Internal 4-ms Soft-Start Time
- Thermal Shutdown Protection at 145°C

APPLICATIONS

- Cable Modem CPE
- Digital Set Top Box
- Graphics/Audio Cards
- Entry Level and Mid-Range Servers

CONTENTS

Device Ratings	3
Electrical Characteristics	4
Typical Characteristics	6
Terminal Information	9
Application Information	11
Design Example	19
Additional References	29

DESCRIPTION

TPS40192 and TPS40193 are cost-optimized synchronous buck controllers that operate from 4.5 V to 18 V input. These controllers implement a voltage-mode control architecture with the switching frequency fixed at either 600 kHz (TPS40192) or 300 kHz (TPS40193). The higher switching frequency facilitates the use of smaller inductor and output capacitors, thereby providing a compact power-supply solution. An adaptive anti-cross conduction scheme is used to prevent shoot through current in the power FETs.

SIMPLIFIED APPLICATION DIAGRAM

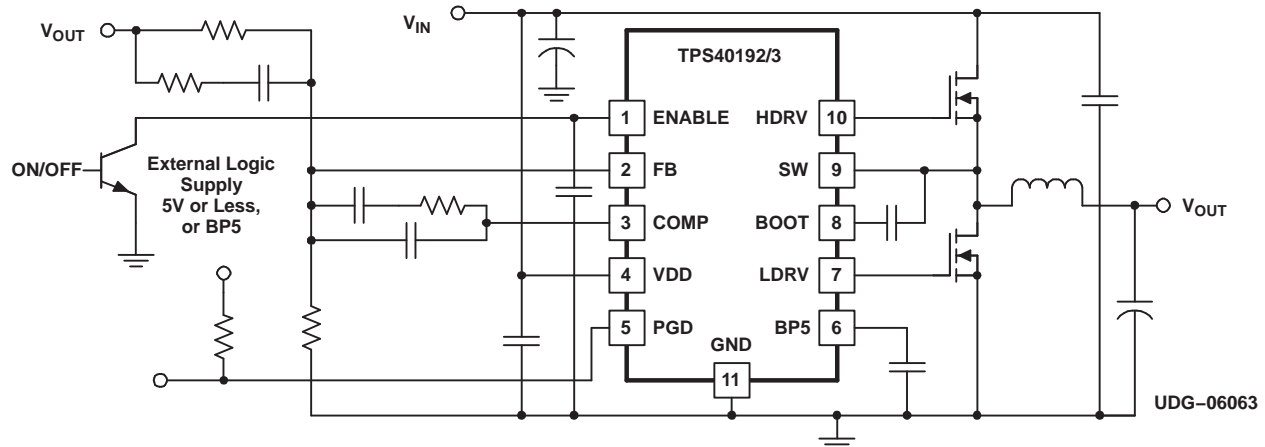

Please be aware that an important notice concerning availability, standard warranty, and use in critical applications of Texas Instruments semiconductor products and disclaimers thereto appears at the end of this data sheet.



These devices have limited built-in ESD protection. The leads should be shorted together or the device placed in conductive foam during storage or handling to prevent electrostatic damage to the MOS gates.

DESCRIPTION (continued)

Short circuit detection is done by sensing the voltage drop across the low-side MOSFET when it is on and comparing it with a user selected threshold of 100 mV, 200 mV or 280 mV. The threshold is set with a single external resistor connected from COMP to GND. This resistor is sensed at startup and the selected threshold is latched. Pulse by pulse limiting (to prevent current runaway) is provided by sensing the voltage across the high-side MOSFET when it is on and terminating the cycle when the voltage drop rises above a fixed threshold of 550 mV. When the controller senses an output short circuit, both MOSFETs are turned off and a timeout period is observed before attempting to restart. This provides limited power dissipation in the event of a sustained fault.

ORDERING INFORMATION

T _J	PACKAGE	FREQUENCY (kHz)	TAPE AND REEL QUANTITY	PART NUMBER
-40°C to 85°C	Plastic 10-Pin SON (DRC)	300	250	TPS40193DRCT
			3000	TPS40193DRCR
		600	250	TPS40192DRCT
			3000	TPS40192DRCR

DEVICE RATINGS

ABSOLUTE MAXIMUM RATINGS

over operating free-air temperature range unless otherwise noted⁽¹⁾

		TPS40192/TPS40193	UNIT
Input voltage range	VDD, ENABLE	-0.3 to 20	V
	SW	-5 to 25	
	BOOT, HDRV	-0.3 to 30	
	BOOT-SW, HDRV-SW (differential from BOOT or HDRV to SW)	-0.3 to 6	
	COMP, FB, BP5, LDRV, PGD	-0.3 to 6	
T _J Operating junction temperature range	-40 to 150	°C	
T _{stg} Storage temperature	-55 to 150		

(1) Stresses beyond those listed under "absolute maximum ratings" may cause permanent damage to the device. These are stress ratings only, and functional operation of the device at these or any other conditions beyond those indicated under "recommended operating conditions" is not implied. Exposure to absolute-maximum-rated conditions for extended periods may affect device reliability.

RECOMMENDED OPERATING CONDITIONS

		MIN	NOM	MAX	UNIT
V _{VDD}	Input voltage	4.5		18	V
T _J	Operating Junction temperature	-40		125	°C

PACKAGE DISSIPATION RATINGS

PACKAGE	AIRFLOW (LFM)	R _{θJA} High-K Board ⁽¹⁾ (°C/W)	Power Rating (W) T _A = 25°C	Power Rating (W) T _A = 85°C
DRC	0 (Natural Convection)	47.9	2.08	0.835
	200	40.5	2.46	0.987
	400	38.2	2.61	1.04

(1) Ratings based on JEDEC High Thermal Conductivity (High K) Board. For more information on the test method, see TI Technical Brief SZZA017.

ELECTROSTATIC DISCHARGE (ESD) PROTECTION

		MIN	TYP	MAX	UNIT
Human Body Model (HBM)			2500		V
Charged Device Model (CDM)			1500		

ELECTRICAL CHARACTERISTICS

T_J = -40°C to 85°C, V_{VDD} = 12 V_{dc}, all parameters at zero power dissipation (unless otherwise noted)

PARAMETER		TEST CONDITIONS	MIN	TYP	MAX	UNIT
REFERENCE						
V _{FB}	Feedback voltage range	0°C ≤ T _J ≤ 85°C	588	591	594	mV
		-40°C ≤ T _J ≤ 85°C	585	591	594	
INPUT SUPPLY						
V _{VDD}	Input voltage range		4.5		18.0	V
I _{VDD}	Operating current	V _{ENABLE} = 3 V		2.5	4.0	mA
		V _{ENABLE} = 0.6 V		45	70	μA
ON BOARD REGULATOR						
V _{5VBP}	Output voltage	V _{VDD} > 6 V, I _{5VBP} ≤ 10 mA	5.1	5.3	5.5	V
V _{DO}	Regulator dropout voltage	V _{VDD} - V _{BP5} , V _{VDD} = 5 V, I _{BP5} ≤ 25 mA		350	550	mV
I _{SC}	Regulator current limit threshold		50			mA
I _{BP5}	Average current				50	
OSCILLATOR						
f _{SW}	Switching frequency	TPS40193	240	300	360	kHz
		TPS40192	500	600	700	
V _{RMP}	Ramp amplitude ⁽¹⁾			1		V
PWM						
D _{MAX}	Maximum duty cycle ⁽¹⁾		85%			
t _{ON(min)}	Minimum controlled pulse ⁽¹⁾				110	ns
t _{DEAD}	Output driver dead time	HDRV off to LDRV on		50		
		LDRV off to HDRV on		25		
SOFT-START						
t _{SS}	Soft-start time		3	4	6	ms
t _{SSDLY}	Soft-start delay time			2		
t _{REG}	Time to regulation			6		
ERROR AMPLIFIER						
GBWP	Gain bandwidth product ⁽¹⁾		7	10		MHz
A _{OL}	DC gain ⁽¹⁾		60			dB
I _{IB}	Input bias current (current out of FB pin)				100	nA
I _{EAOP}	Output source current	V _{FB} = 0 V	1			mA
I _{EAOM}	Output sink current	V _{FB} = 2 V	1			
SHORT CIRCUIT PROTECTION						
t _{PSS(min)}	Minimum pulse during short circuit ⁽¹⁾			250		ns
t _{BLNK}	Blanking time ⁽¹⁾		60	90	120	
t _{OFF}	Off-time between restart attempts		30	50		ms
V _{ILIM}	Short circuit comparator threshold voltage	R _{COMP(GND)} = OPEN, T _J = 25°C	160	200	240	mV
		R _{COMP(GND)} = 4 kΩ, T _J = 25°C	80	100	120	
		R _{COMP(GND)} = 12 kΩ, T _J = 25°C	228	280	342	
V _{ILIMH}	Short circuit threshold voltage on high-side MOSFET	T _J = 25°C	400	550	650	

(1) Specified by design. Not production tested.

ELECTRICAL CHARACTERISTICS (continued)
 $T_J = -40^{\circ}\text{C}$ to 85°C , $V_{VDD} = 12 V_{dc}$, all parameters at zero power dissipation (unless otherwise noted)

PARAMETER		TEST CONDITIONS	MIN	TYP	MAX	UNIT
OUTPUT DRIVERS						
R_{HDHI}	High-side driver pull-up resistance	$V_{BOOT} - V_{SW} = 4.5 V$, $I_{HDRV} = -100 mA$		3	6	Ω
R_{HDLO}	High-side driver pull-down resistance	$V_{BOOT} - V_{SW} = 4.5 V$, $I_{HDRV} = 100 mA$		1.5	3.0	
R_{LDHI}	Low-side driver pull-up resistance	$I_{LDRV} = -100 mA$		2.5	5.0	
R_{LDLO}	Low-side driver pull-down resistance	$I_{LDRV} = 100 mA$		0.8	1.5	
t_{HRISE}	High-side driver rise time ⁽²⁾	$C_{LOAD} = 1 nF$		15	35	ns
t_{HFALL}	High-side driver fall time ⁽²⁾			10	25	
t_{LRISE}	Low-side driver rise time ⁽²⁾			15	35	
t_{LFALL}	Low-side driver fall time ⁽²⁾			10	25	
UVLO						
V_{UVLO}	Turn-on voltage		3.9	4.2	4.4	V
$UVLO_{HYST}$	Hysteresis		700	800	900	mV
SHUTDOWN						
V_{IH}	High-level input voltage, ENABLE			1.9	3.0	V
V_{IL}	Low-level input voltage, ENABLE		0.6			
POWER GOOD						
V_{OV}	Feedback voltage limit for powergood			650		mV
V_{UV}	Feedback voltage limit for powergood			525		
V_{PG_HYST}	Powergood hysteresis voltage at FB pin			30		
R_{PGD}	Pulldown resistance of PGD pin	$V_{FB} = 0 V$		7	50	Ω
I_{PDGLK}	Leakage current	$V_{FB} = 0 V$		7	12	μA
BOOT DIODE						
V_{DFWD}	Bootstrap diode forward voltage	$I_{BOOT} = 5 mA$	0.5	0.8	1.2	V
THERMAL SHUTDOWN						
T_{JSD}	Junction shutdown temperature ⁽²⁾			145		$^{\circ}\text{C}$
T_{JSDH}	Hysteresis ⁽²⁾			20		

(2) Specified by design. Not production tested.

TYPICAL CHARACTERISTICS

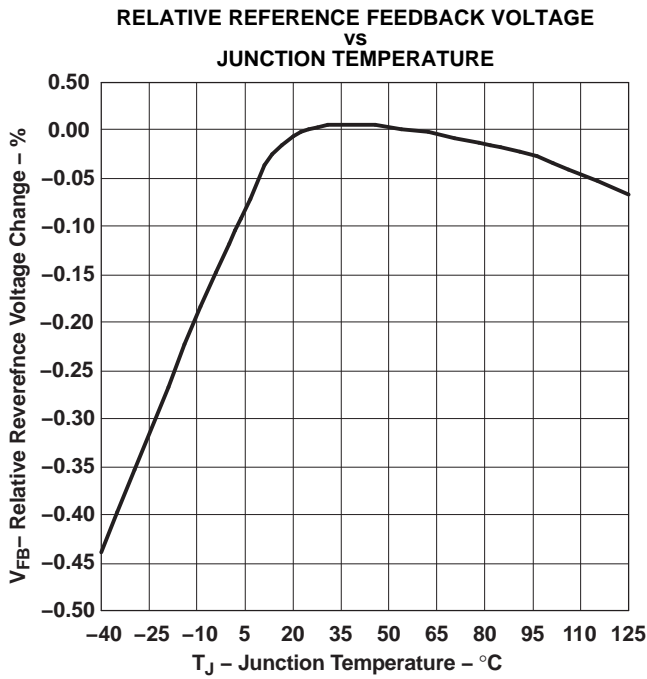

Figure 1.

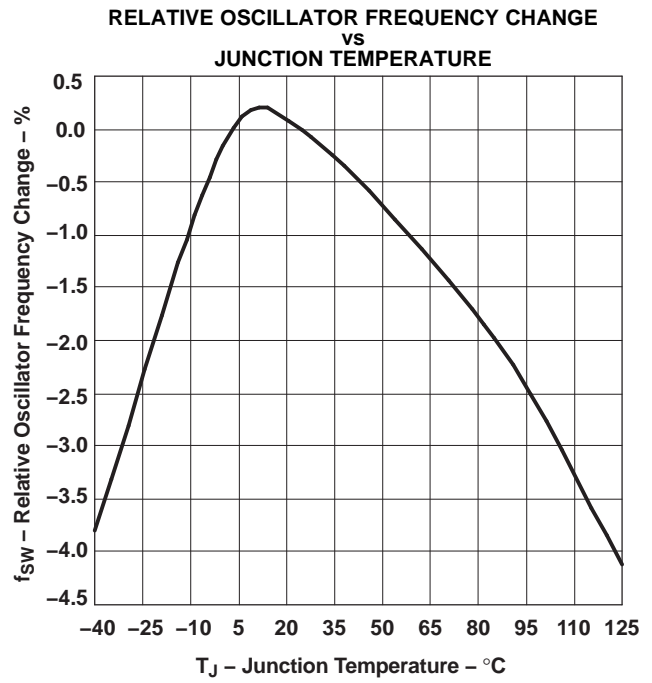

Figure 2.

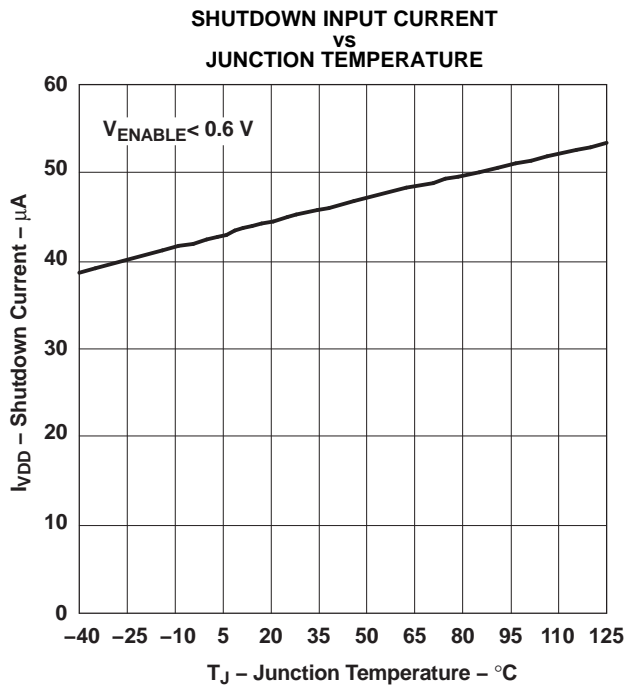

Figure 3.

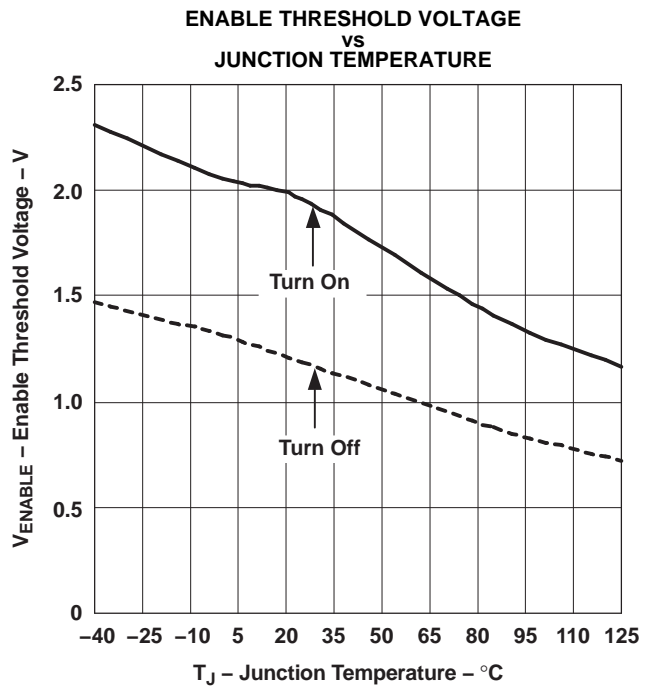

Figure 4.

TYPICAL CHARACTERISTICS (continued)

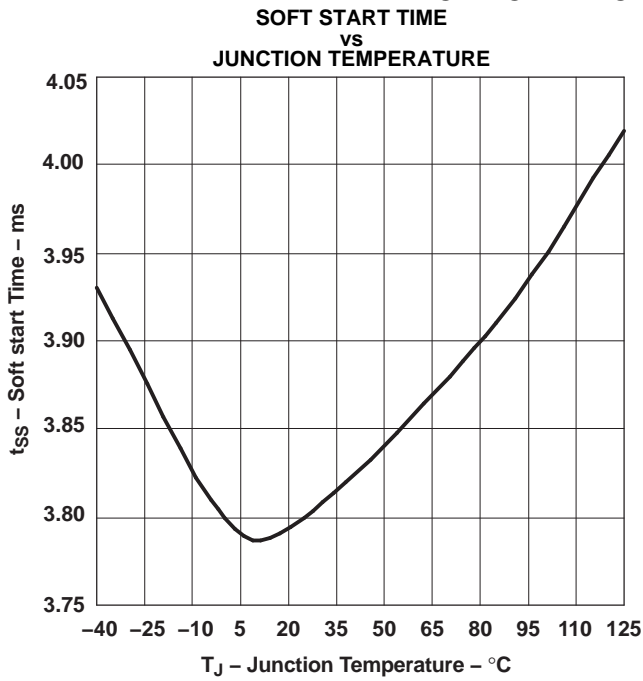

Figure 5.

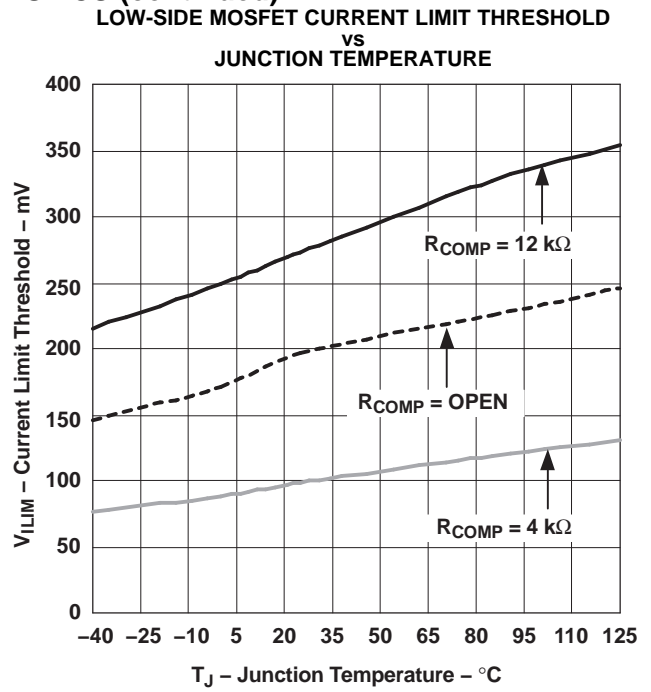

Figure 6.

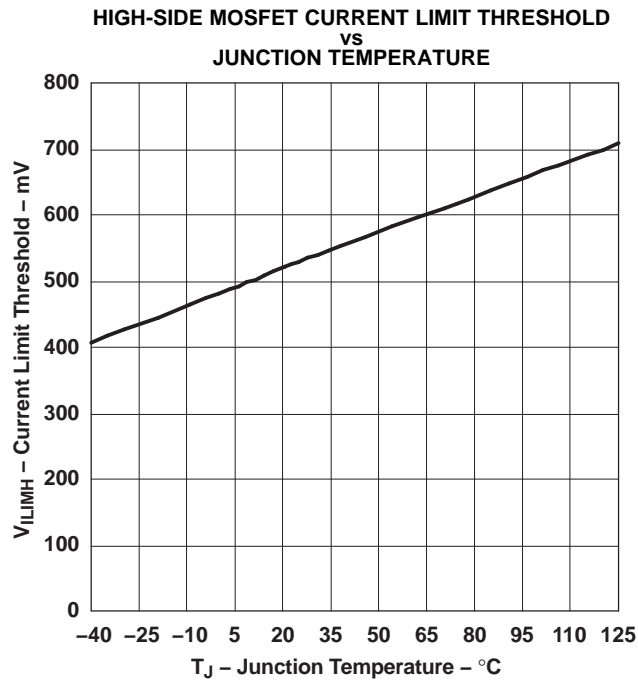

Figure 7.

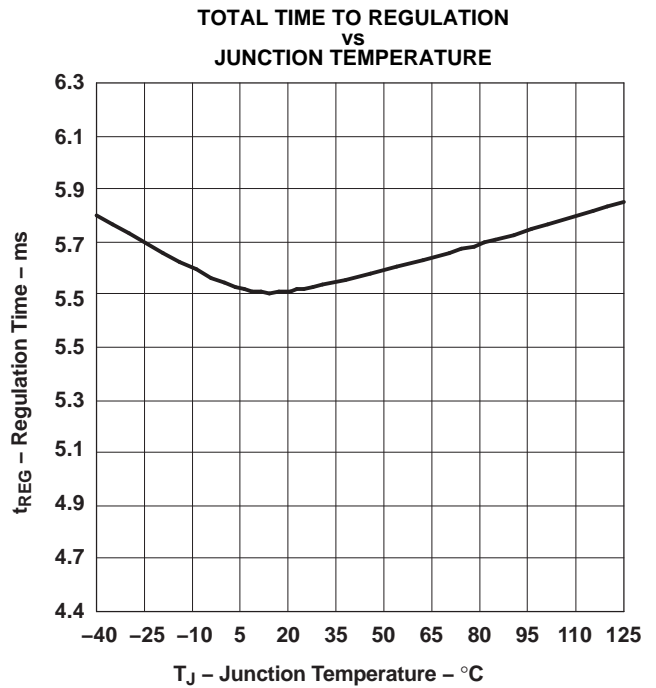
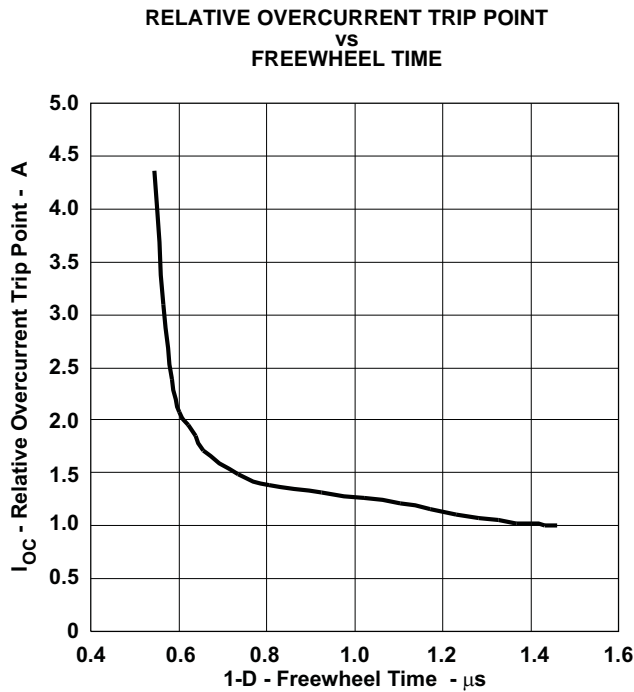
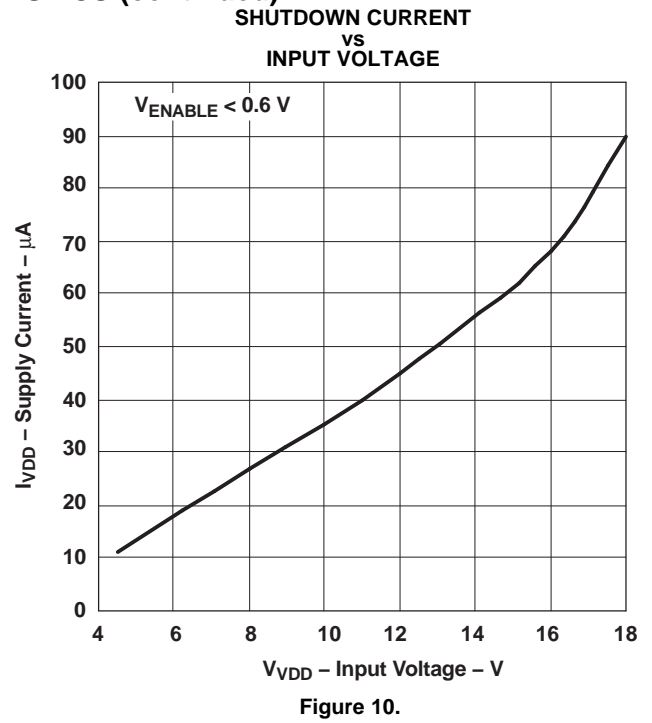
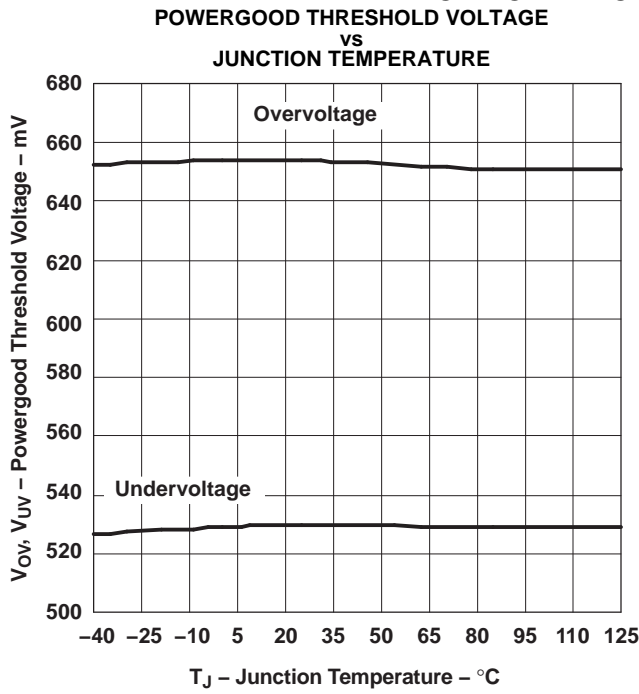

Figure 8.

TYPICAL CHARACTERISTICS (continued)



DEVICE INFORMATION
Table 1. TERMINAL FUNCTIONS

TERMINAL		I/O	DESCRIPTION
NAME	NO.		
BOOT	8	I	Gate drive voltage for the high-side N-channel MOSFET. A capacitor 100 nF typical must be connected between this pin and SW.
BP5	6	O	Output bypass for the internal regulator. Connect at least 1 μ F capacitor from this pin to GND. Larger capacitors, up to 4.7 μ F will improve noise performance when using a low side FET with a gate charge of 25nC or greater. Low power, low noise loads may be connected here if desired. The sum of the external load and the gate drive requirements must not exceed 50 mA. This regulator is turned off when ENABLE is pulled low.
COMP	3	O	Output of the error amplifier.
ENABLE	1	I	Logic level input which starts or stops the controller from an external user command. A high-level turns the controller on. A weak internal pull-up holds this pin high so that the pin may be left floating if this function is not used.
FB	2	I	Inverting input to the error amplifier. In normal operation the voltage on this pin is equal to the internal reference voltage (591 mV typical)
GND	(11)	-	Thermal pad ground connection. Common reference for the device. Connect to the system GND.
HDRV	10	O	Bootstrapped output for driving the gate of the high side N channel FET.
LDRV	7	O	Output to the rectifier MOSFET gate
PGD	5	O	Open drain power good output
SW	9	I	Sense line for the adaptive anti-cross conduction circuitry. Serves as common connection for the flying high side MOSFET driver
VDD	4	I	Power input to the controller

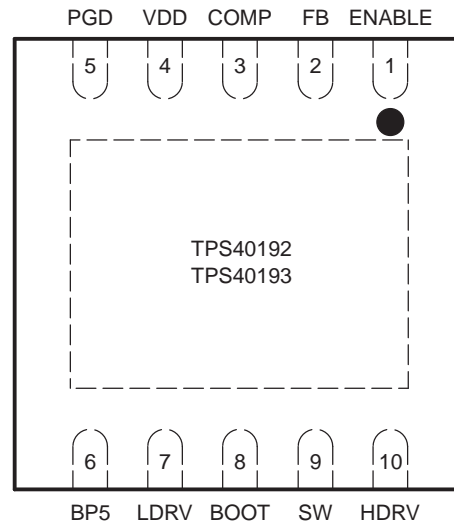
**DRC PACKAGE
(TOP VIEW)**

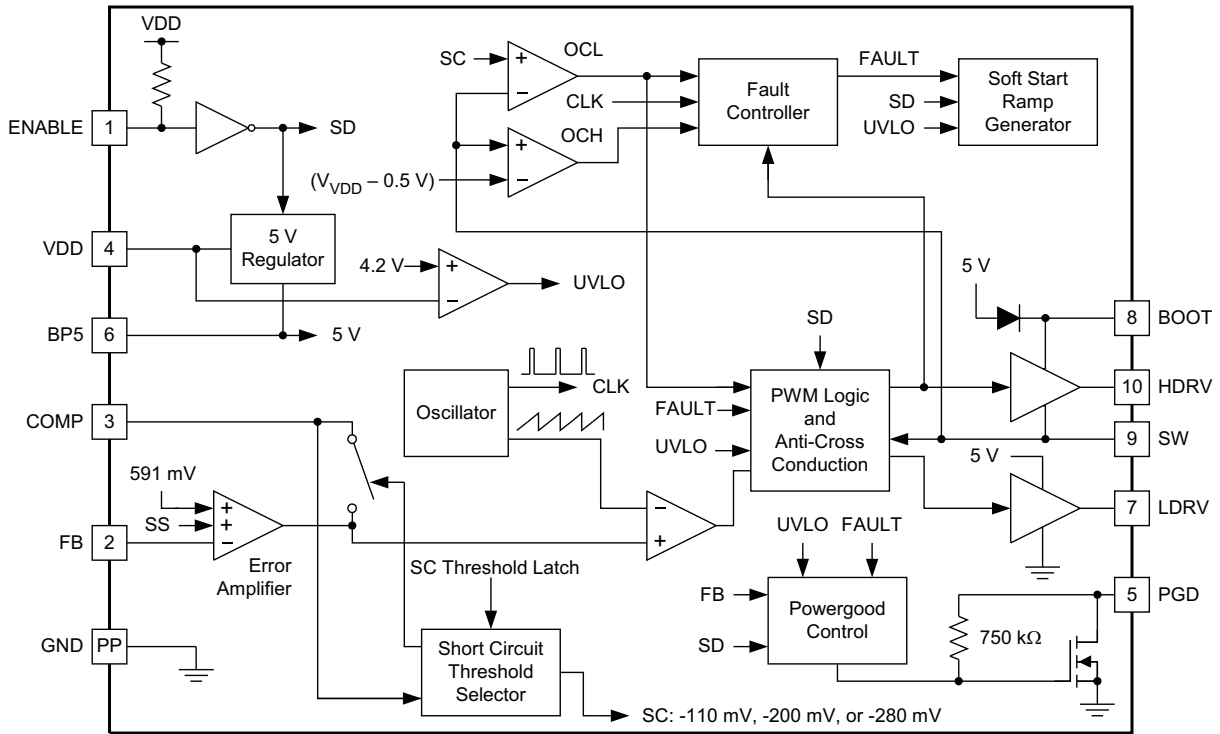

UDG-06064

APPLICATION INFORMATION

Introduction

The TPS40192 and TPS40193 are cost optimized controllers providing all the necessary features to construct a high performance DC/DC converter while keeping costs to a minimum. Support for pre-biased outputs eliminates concerns about damaging sensitive loads during startup. Strong gate drivers for the high side and rectifier N-channel MOSFETs decrease switching losses for increased efficiency. Adaptive gate drive timing prevents shoot through and minimizes body diode conduction in the rectifier MOSFET, also increasing efficiency. Selectable short circuit protection thresholds and hiccup recovery from a short circuit increase design flexibility and minimize power dissipation in the event of a prolonged output fault. The dedicated ENABLE pin allows the converter to be placed in a very low quiescent current shutdown mode. Internally fixed switching frequency and soft-start time reduce external component count, simplifying design and layout, as well as reducing footprint and cost. The 3 mm × 3 mm package size also contributes to a reduced overall converter footprint.

Voltage Reference

The band gap cell is designed with a trimmed 591-mV output. The 0.5% tolerance on the reference voltage allows the user to design a very accurate power-supply.

Oscillator

The TPS40192 has a fixed internal switching frequency of 600 kHz. The TPS40193 operates at a switching frequency of 300 kHz.

UVLO

When the input voltage is below the UVLO threshold, the device holds all gate drive outputs in the low (OFF) state. When the input rises above the UVLO threshold, and the ENABLE pin is above the turn ON threshold, the oscillator begins to operate and the start-up sequence is allowed to begin. The UVLO level is internally fixed at 4.2 V.

Enable Functionality

The TPS40192 and TPS40193 have a dedicated ENABLE pin. This simplifies user level interface design since no multiplexed functions exist. Another benefit is a true low power shutdown mode of operation. When the ENABLE pin is pulled to GND, all unnecessary functions, including the BP5 regulator, are turned off, reducing the device I_{DD} current to 45- μ A. A functionally equivalent circuit of the enable circuitry shown in [Figure 12](#).

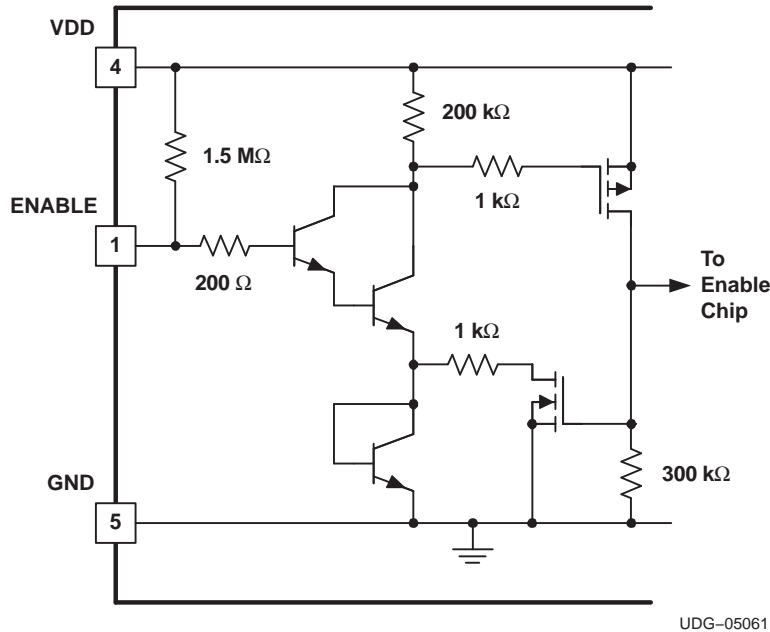

Figure 12. TPS40192 ENABLE Pin Internal Circuitry

If the ENABLE pin is left floating, the chip starts automatically. The pin must be pulled to less than 600 mV to ensure that the TPS40192/3 is in shutdown mode. Note that the ENABLE pin is relatively high impedance. In some situations, there could be enough noise nearby to cause the ENABLE pin to swing below the 600 mV threshold and give erroneous shutdown commands to the rest of the device. There are two solutions to solve this problem.

1. Place a capacitor from ENABLE to GND. A side effect of this is to delay the start of the converter while the capacitor charges past the enable threshold
2. Place a resistor from VDD to ENABLE. This causes more current to flow in the shutdown mode, but does not delay converter startup. If a resistor is used, the total current into the ENABLE pin should be limited to no more than 500 μ A.

The ENABLE pin is self-clamping. The clamp voltage can be as low as 1 V with a 1-k Ω ground impedance. Due to this self-clamping feature, the pull-up impedance on the ENABLE pin should be selected to limit the sink current to less than 500 μ A. Driving the ENABLE pin with a low-impedance source voltage can result in damage to the device. Because of the self-clamping feature, it requires care when connecting multiple ENABLE pins together. For enabling multiple TPS4019x devices (TPS40190, TPS40192, TPS40193, TPS40195, TPS40197), see the Application Report [SLVA509](#).

Startup Sequence and Timing

The TPS40192/3 startup sequence is as follows. After input power is applied, the 5-V onboard regulator comes up. Once this regulator comes up, the device goes through a period where it samples the impedance at the COMP pin and determines the short circuit protection threshold voltage, by placing 400 mV on the COMP pin for approximately 1 ms. During this time, the current is measured and compared against internal thresholds to select the short circuit protection threshold. After this, the COMP pin is brought low for 1 ms. This ensures that the feedback loop is preconditioned at startup and no sudden output rise occurs at the output of the converter when the converter is allowed to start switching. After these initial two milliseconds, the internal soft-start circuitry is engaged and the converter is allowed to start. See [Figure 13](#).

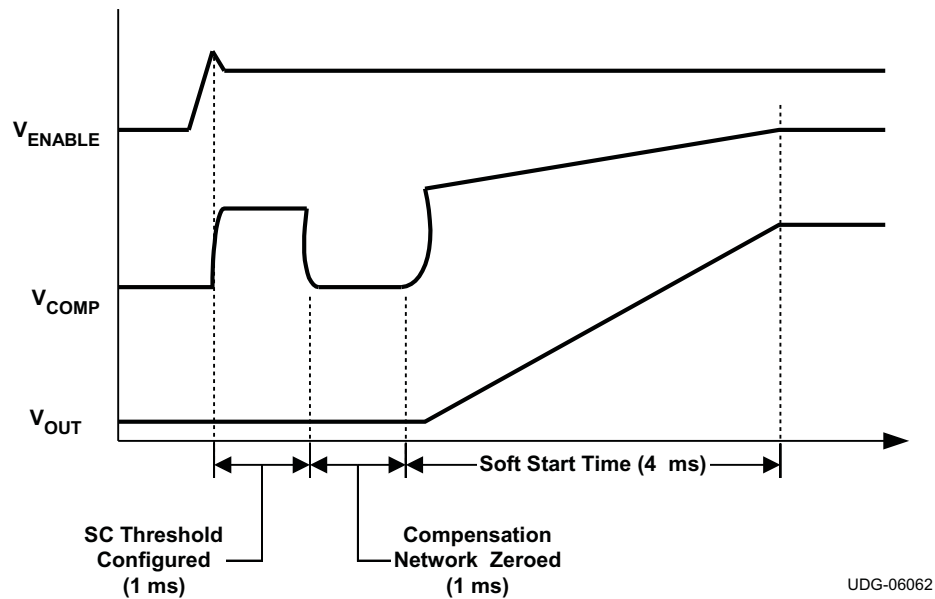

Figure 13. Startup Sequence

Selecting the Short Circuit Current

A short circuit in the TPS40192/3 is detected by sensing the voltage drop across the low-side FET when it is on, and across the high-side FET when it is on. If the voltage drop across either FET exceeds the short circuit threshold in any given switching cycle, a counter increments one count. If the voltage drop across the high-side FET was higher than the short circuit threshold, that FET is turned off early. If the voltage drop across either FET does not exceed the short circuit threshold during a cycle, the counter is decremented for that cycle. If the counter fills up (a count of 7) a fault condition is declared and the drivers turn off both MOSFETs. After a timeout of approximately 50 ms, the controller attempts to restart. If a short circuit is still present at the output, the current quickly ramps up to the short circuit threshold and another fault condition is declared and the process of waiting for the 50 ms an attempting to restart repeats. The low side threshold will increase as the low side on time decreases due to blanking time and comparator response time. See Figure 11 for changes in the threshold as the low side FET conduction time decreases.

The TPS40192/3 provides three selectable short circuit protection thresholds for the low side FET: 100 mV, 200 mV and 280 mV. The particular threshold is selected by connecting a resistor from COMP to GND. Table 2 shows the short circuit thresholds for corresponding resistors from COMP to GND. When designing the compensation for the feedback loop, remember that a low impedance compensation network combined with a long network time constant can cause the short circuit threshold setting to not be as expected. The time constant and impedance of the network connected from COMP to FB should be as in Equation 1 to ensure no interaction with the short circuit threshold setting.

$$\frac{0.4 \text{ V}}{R1} \times e\left(\frac{-t}{R1 \times C1}\right) < 10 \mu\text{A}$$

where

- t is 1 ms, the sampling time of the short circuit threshold setting circuit
- R1 and C1 are the values of the components in Figure 14

(1)

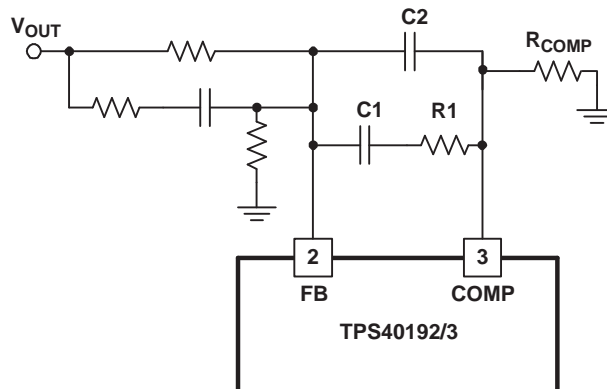

UDG-06061

Figure 14. Short Circuit Threshold Feedback Network

Table 2. Short Circuit Threshold Voltage Selection

COMPARATOR RESISTANCE R _{COMP} (kΩ)	CURRENT LIMIT THRESHOLD VOLTAGE (mV) V _{ILIM} (V)
12 ±10%	280
Open	200
4 ±10%	100

The range of short circuit current thresholds that can be expected is shown in [Equation 2](#) and [Equation 3](#).

$$I_{SCP(max)} = \frac{V_{ILIM(max)}}{R_{DS(on)min}} \quad (2)$$

$$I_{SCP(min)} = \frac{V_{ILIM(min)}}{R_{DS(on)max}}$$

where

- I_{SCP} is the short circuit current
 - V_{ILIM} is the short circuit threshold for the low-side MOSFET
 - $R_{DS(on)}$ is the channel resistance of the low-side MOSFET
- (3)

Note that due to blanking time considerations, overcurrent threshold accuracy may fall off for duty cycle greater than 75% with the TPS40192, or 88% with the TPS40193. The reason for this is that the over current comparator will have only a very short time to sample the SW pin voltage under these conditions and may not have time to respond to voltages very near the threshold.

The short circuit protection threshold for the high-side MOSFET is fixed at 550 mV typical, 400 mV minimum. This threshold is in place to provide a maximum current output using pulse by pulse current limit in the case of a fault. The pulse will be terminated when the voltage drop across the high side FET exceeds the short circuit threshold. The maximum amount of current that can be specified to be sourced from a converter is found by [Equation 4](#).

$$I_{OUT(max)} = \frac{V_{ILIMH(min)}}{R_{DS(on)max}}$$

where

- $I_{OUT(max)}$ is the maximum current that the converter is specified to source
 - $V_{ILIMH(min)}$ is the short circuit threshold for the high-side MOSFET (400 mV)
 - $R_{DS(on)max}$ is the maximum resistance of the high-side MOSFET
- (4)

If the required current from the converter is greater than the calculated $I_{OUT(max)}$, a lower resistance high-side MOSFET must be chosen. Both the high side and low side thresholds use temperature compensation to approximate the change in resistance for a typical power MOSFET. This will help counteract shifts in overcurrent thresholds as temperature increases. For this to be effective, the MOSFETs and the device must be well coupled thermally.

5-V Regulator

These devices have an on board 5-V regulator that allows the parts to operate from a single voltage feed. No separate 5-V feed to the part is required. This regulator needs to have a minimum of 1- μ F of capacitance on the BP5 pin for stability. A ceramic capacitor is suggested for this purpose.

This regulator can also be used to supply power to nearby circuitry, eliminating the need for a separate LDO in some cases. If this pin is used for external loads, be aware that this is the power supply for the internals of the TPS40192/3. While efforts have been made to reduce sensitivity, any noise induced on this line has an adverse effect on the overall performance of the internal circuitry and shows up as increased pulse jitter, or skewed reference voltage. Also, when the device is disabled by pulling the EN pin low, this regulator is turned off and will not be available to supply power.

The amount of power available from this pin varies with the size of the power MOSFETs that the drivers must operate. Larger MOSFETs require more gate drive current and reduce the amount of power available on this pin for other tasks. The total current that can be drawn from this pin by both the gate drive and external loads cannot exceed 50mA. The device uses up to 4mA from the regulator and the total gate drive current can be found from [Equation 5](#).

For regulator stability, a 1- μ F capacitor is required to be connected from BP5 to GND. In some applications using higher gate charge MOSFETs, a larger capacitor is required for noise suppression. For a total gate charge of both the high and low side MOSFETs greater than 20 nC, a 2.2- μ F or larger capacitor is recommended.

$$I_G = f_{SW} \times (Q_{G(\text{high})} + Q_{G(\text{low})})$$

where

- I_G is the required gate drive current
- f_{SW} is the switching frequency (600 kHz for TPS40192, and 300 kHz for TPS40193)
- $Q_{G(\text{high})}$ is the gate charge requirement for the high-side FET when $V_{GS}=5$ V
- $Q_{G(\text{low})}$ is the gate charge requirement for the low-side FET when $V_{GS}=5$ V

(5)

Pre-Bias Startup

The TPS40192/3 contains a unique circuit to prevent current from being *pulled* from the output during startup in the condition the output is pre-biased. When the soft-start commands a voltage higher than the pre-bias level (internal soft-start becomes greater than feedback voltage [V_{FB}]), the controller slowly activates synchronous rectification by starting the first LDRV pulses with a narrow on-time. It then increments that on-time on a cycle-by-cycle basis until it coincides with the time dictated by $(1-D)$, where D is the duty cycle of the converter. This scheme prevents the initial sinking of the pre-bias output, and ensures that the out voltage (V_{OUT}) starts and ramps up smoothly into regulation and the control loop is given time to transition from pre-biased startup to normal mode operation with minimal disturbance to the output voltage. The amount of time from the start of switching until the low-side MOSFET is turned on for the full $(1-D)$ interval is defined by 32 clock cycles.

Drivers

The drivers for the external HDRV and LDRV MOSFETs are capable of driving a gate-to-source voltage of 5 V. The LDRV driver switches between VDD and GND, while HDRV driver is referenced to SW and switches between BOOT and SW. The drivers have non-overlapping timing that is governed by an adaptive delay circuit to minimize body diode conduction in the synchronous rectifier. The drivers are capable of driving MOSFETs that are appropriate for a 15-A (TPS40192) or 20-A (TPS40193) converter.

Power Good

The TPS40192/3 provides an indication that output power is good for the converter. This is an open drain signal and pulls low when any condition exists that would indicate that the output of the supply might be out of regulation. These conditions include:

- V_{FB} is more than $\pm 10\%$ from nominal
- soft-start is active
- an undervoltage condition exists for the device
- a short circuit condition has been detected
- die temperature is over (145°C)

NOTE

When there is no power to the device, PGOOD is not able to pull close to GND if an auxiliary supply is used for the power good indication. In this case, a built in resistor connected from drain to gate on the PGOOD pull down device makes the PGOOD pin look approximately like a diode to GND.

Thermal Shutdown

If the junction temperature of the device reaches the thermal shutdown limit of 145°C , the PWM and the oscillator are turned off and HDRV and LDRV are driven low, turning off both FETs. When the junction cools to the required level (125°C nominal), the PWM initiates soft start as during a normal power up cycle.

Layout Recommendations and Sample Layout

Layout Recommendations:

- PowerPad™ is the only GND connection to the device (U1). PowerPad™ must be connected to ground.
- PowerPad™ should be directly connected to SYNC FET (Q3) source with short, wide trace.
- Locate 3-5 vias in PowerPad™ land to remove heat from the device.
- Connect input capacitors (C7 & C9) and output capacitors (C8 & C10) grounds directly to SYNC FET (Q3) source with wide copper trace or solid power ground island.
- Locate input capacitors (C7 & C9), MOSFETs (Q2 & Q3), inductor (L1) and output capacitor (C8 & C10) over power ground island.
- Use short, wide traces for LDRV and HDRV MOSFET connections.
- Route SW trace near HDRV trace.
- Route GND trace near LDRV trace.
- Use separate analog ground island under feedback components (C1, C2, C3, R5, R6, R7, R8 & R10).
- Connect ground islands at PowerPad™ with 10-mil wide trace opposite SYNC FET (Q2) source connection.

Sample Layout:

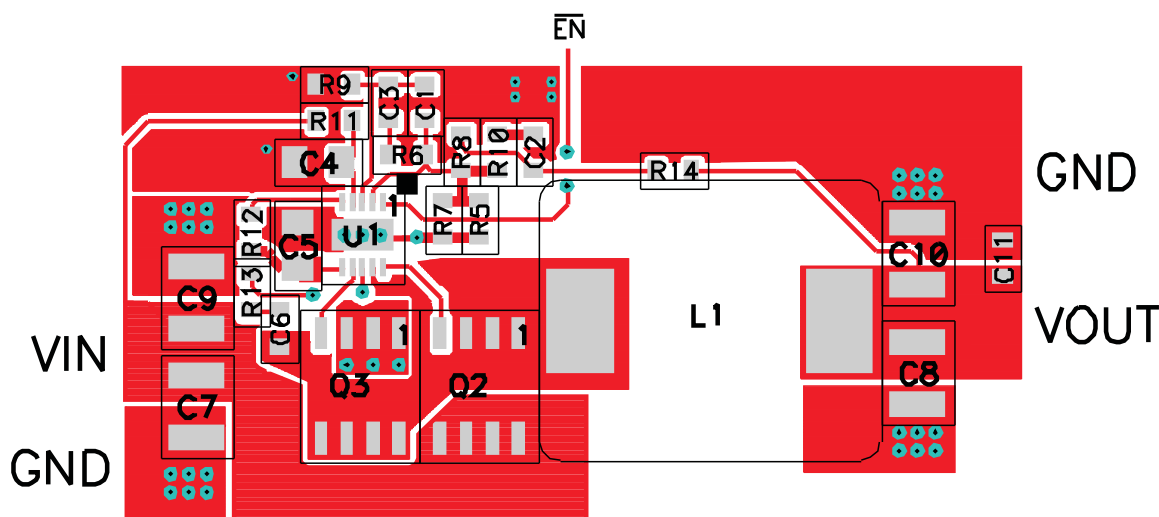

Figure 15. TPS40192/3 Sample Layout - Component Placement and Top Side Copper

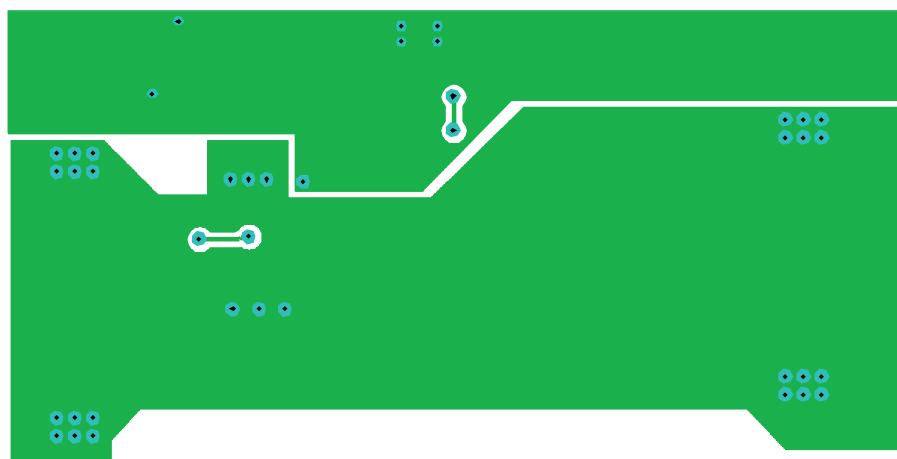

Figure 16. TPS40192/3 Sample Layout - Bottom Side Copper (X-Ray view from Top)

DESIGN EXAMPLE

Introduction

This example illustrates the design process and component selection for a 12 V to 1.8 V point-of-load synchronous buck regulator using the TPS40192. A definition of symbols used can be found in Table 8 of this datasheet.

Table 3. Design Example Electrical Characteristics

PARAMETER	TEST CONDITION	MIN	NOM	MAX	UNIT
V _{IN} Input voltage		8		14	V
V _{IN(ripple)} Input ripple	I _{OUT} = 10 A			0.6	
V _{OUT} Output voltage	0 A ≤ I _{OUT} ≤ 10 A	1.764	1.800	1.836	
Line regulation	8.0 V ≤ V _{IN} ≤ 14 V			0.5%	
Load regulation	0 A ≤ I _{OUT} ≤ 10 A			0.5%	
V _{RIPPLE} Output ripple	I _{OUT} = 10 A			36	mV
V _{OVER} Output overshoot	3 A ≤ I _{OUT} ≤ 7 A		50		
V _{UNDER} Output undershoot			50		
I _{OUT} Output current		0		10	A
I _{SCP} Short circuit current trip point					
η Efficiency	V _{IN} = 12 V, I _{OUT} = 5 A			90%	
f _{SW} Switching frequency			600		kHz
Size					

The list of materials for this application is shown Table 7. The efficiency, line and load regulation from boards built using this design are shown in Figure 17 and Table 3. Gerber Files and additional application information are available from the factory.

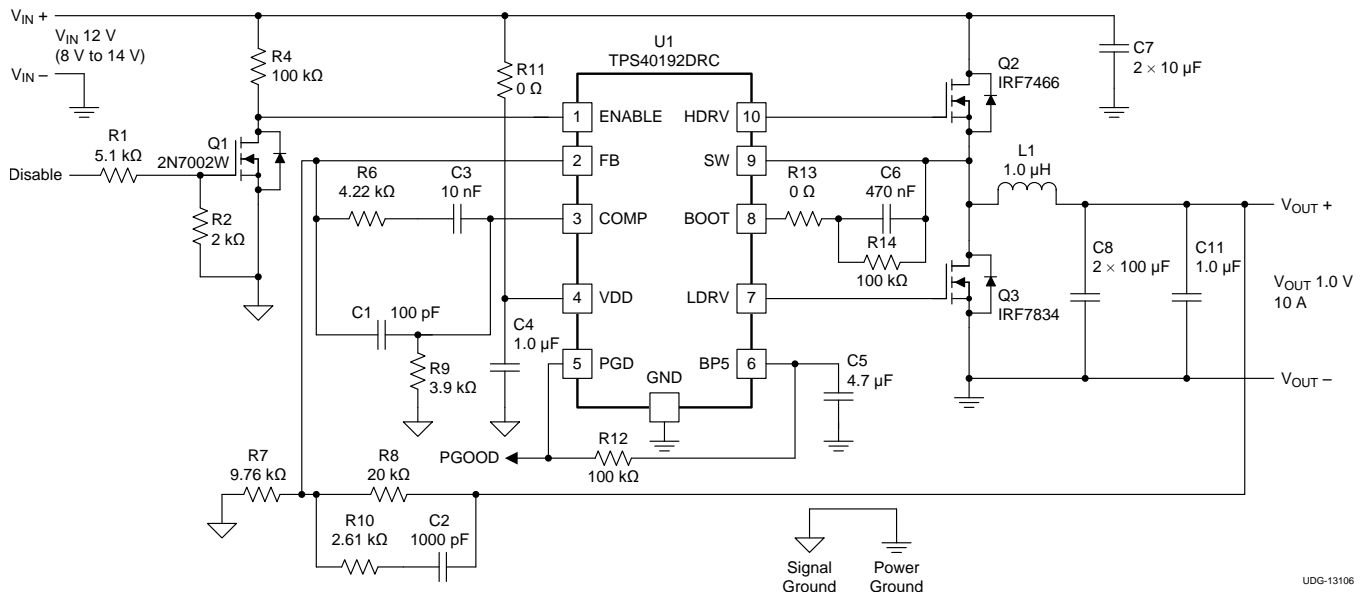

Figure 17. TPS40192 Design Example Schematic

Design Example Considerations

- Optionally use R11 as a VDD filter resistor
- Locate the bypass capacitors (C7) near the power MOSFETs.
- Terminate signal components to a signal ground island separate from power ground

- Connect signal ground island to PowerPad with a single 10-mil wide trace.
- Connect power ground to the source of the synchronous rectifier.
- The PowerPad serves as the only ground for the controller.
- PowerPAD must be connected to signal ground and power ground.

Design Procedure

Selecting the Switching Frequency

For this design the TPS40192, with $f_{SW} = 600$ kHz, is selected to reduce inductor and capacitor sizes.

Inductor Selection

The inductor is typically sized for approximately 30% peak-to-peak ripple current (I_{RIPPLE}). Given this target ripple current, the required inductor size can be calculated by [Equation 6](#).

$$L \approx \frac{V_{IN(max)} - V_{OUT}}{0.3 \times I_{OUT}} \times \frac{V_{OUT}}{V_{IN(max)}} \times \frac{1}{f_{SW}}$$

Solving this for

- $V_{IN(max)} = 14$ V
 - $V_{OUT} = 1.8$ V
 - $I_{OUT} = 10$ A
 - $f_{SW} = 600$ kHz
- (6)

an inductor value of 0.87 μ H is obtained.

A standard value of 1.0 μ H is selected. Solving for I_{RIPPLE} with 1.0 μ H results in 2.6-A peak-to-peak ripple.

The RMS current through the inductor is approximated by [Equation 7](#).

$$I_{L(rms)} = \sqrt{(I_{L(avg)})^2 + \frac{1}{12}(I_{RIPPLE})^2} = \sqrt{(I_{OUT})^2 + \frac{1}{12}(I_{RIPPLE})^2}$$
(7)

Using [Equation 7](#), the maximum RMS current in the inductor is approximately 10.03 A

Output Capacitor Selection (C8)

The selection of the output capacitor is typically driven by the output transient response. The [Equation 8](#) and [Equation 9](#) overestimate the voltage deviation to account for delays in the loop bandwidth and can be used to determine the required output capacitance.

$$V_{OVER} < \frac{I_{TRAN}}{C_{OUT}} \times \Delta T = \frac{I_{TRAN}}{C_{OUT}} \times \frac{I_{TRAN} \times L}{V_{OUT}} = \frac{(I_{TRAN})^2 \times L}{V_{OUT} \times C_{OUT}}$$
(8)

$$V_{UNDER} < \frac{I_{TRAN}}{C_{OUT}} \times \Delta T = \frac{I_{TRAN}}{C_{OUT}} \times \frac{I_{TRAN} \times L}{V_{IN} - V_{OUT}} = \frac{(I_{TRAN})^2 \times L}{(V_{IN} - V_{OUT}) \times C_{OUT}}$$

If

- $V_{IN(min)} > 2 \times V_{OUT}$, use overshoot to calculate minimum output capacitance.
 - $V_{IN(min)} < 2 \times V_{OUT}$, use undershoot to calculate minimum output capacitance.
- (9)

$$C_{OUT(min)} = \frac{(I_{TRAN(max)})^2 \times L}{V_{OUT} \times V_{OVER}}$$
(10)

Based on a 4-A load transient with a maximum 50 mV overshoot at 8.0 V input, calculate a minimum 178- μ F output capacitance.

With a minimum capacitance, the maximum allowable ESR is determined by the maximum ripple voltage and is approximated by [Equation 11](#).

$$ESR_{MAX} < \frac{V_{RIPPLE(tot)} - V_{RIPPLE(cap)}}{C_{OUT}} = \frac{V_{RIPPLE(tot)} - \left(\frac{I_{RIPPLE}}{C_{OUT} \times f_{SW}} \right)}{I_{RIPPLE}} \quad (11)$$

Based on 178 μF of capacitance, 2.6-A ripple current, 600-kHz switching frequency and 36-mV ripple voltage, calculate a capacitive ripple of 24.3 mV and a maximum ESR of 4.4 m Ω .

Two 1206 100- μF , 6.3-V X5R ceramic capacitors are selected to provide more than 178- μF of minimum capacitance and less than 4.4 m Ω of ESR (2.5 m Ω each).

Peak Current Rating of the Inductor

With output capacitance, it is possible to calculate the charge current during start-up and determine the minimum saturation current rating for the inductor. The start-up charging current is approximated by [Equation 12](#).

$$I_{CHARGE} = \frac{V_{OUT} \times C_{OUT}}{T_{SS}} \quad (12)$$

Using the TPS40192's minimum soft-start time of 3.0 ms, $C_{OUT} = 240 \mu\text{F}$ and $V_{OUT} = 1.8 \text{ V}$, $I_{CHARGE} = 144 \text{ mA}$.

$$I_{L(peak)} = I_{OUT(max)} + \frac{1}{2} I_{RIPPLE} + I_{CHARGE} \quad (13)$$

Table 4. Inductor Requirements

PARAMETER	SYMBOL	VALUE	UNITS
Inductance	L	1.0	μH
RMS current (thermal rating)	$I_{L(rms)}$	10.03	A
Peak current (saturation rating)	$I_{L(peak)}$	11.3	

A PG0083.102 1.0- μH is selected for its small size, low DCR (6.6 m Ω) and high current handling capability (12 A thermal, 17 A saturation)

Input Capacitor Selection (C7)

The input voltage ripple is divided between capacitance and ESR. For this design $V_{RIPPLE(cap)} = 400 \text{ mV}$ and $V_{RIPPLE(ESR)} = 200 \text{ mV}$. The minimum capacitance and maximum ESR are estimated by [Equation 14](#).

$$C_{IN(min)} = \frac{I_{LOAD} \times V_{OUT}}{V_{RIPPLE(cap)} \times V_{IN} \times f_{SW}} \quad (14)$$

$$ESR_{MAX} = \frac{V_{RIPPLE(esr)}}{I_{LOAD} + \frac{1}{2} I_{RIPPLE}} \quad (15)$$

For this design $C_{IN} > 9.375 \mu\text{F}$ and $ESR < 17.7 \text{ m}\Omega$. The RMS current in the input capacitors is estimated by [Equation 16](#).

$$I_{RMS(Cin)} = I_{IN(rms)} - I_{IN(avg)} = \left(I_{OUT} + \frac{1}{12} I_{RIPPLE} \right) \sqrt{\frac{V_{OUT}}{V_{IN}}} - \frac{V_{OUT} \times I_{OUT}}{V_{IN}} \quad (16)$$

For this design $V_{IN} = 14 \text{ V}$, $V_{OUT} = 1.8 \text{ V}$, $I_{OUT} = 10 \text{ A}$ and $I_{RIPPLE} = 2.6 \text{ A}$ calculate an RMS of 2.37 A, so the total of our input capacitors must support 2.37 A of RMS ripple current.

Two 1210 10- μF 25V X5R ceramic capacitors with about 2 m Ω ESR and a 2- A_{RMS} current rating are selected. Higher voltage capacitors are selected to minimize capacitance loss at the DC bias voltage to ensure the capacitors have sufficient capacitance at the working voltage.

MOSFET Switch Selection (Q1, Q2)

The switching losses for the high-side FET are estimated by [Equation 17](#).

$$P_{G1_SW} = \frac{1}{2} V_{IN} \times I_{OUT} \times T_{SW} \times f_{SW} = \frac{1}{2} V_{IN} \times I_{OUT} \times \frac{Q_{GD1}}{R_{DRV}} \times f_{SW} \tag{17}$$

For this design switching losses will be highest at high-line. Designing for 1 W of total losses in each MOSFETs and 60% of the total high-side FET losses in switching losses, we can estimate our maximum gate-drain charge for the design by using Equation 18.

$$Q_{GD1} < \frac{P_{G1SW}}{V_{IN} \times I_{OUT}} \times \frac{V_{DD} - V_T}{R_{DRV}} \times \frac{1}{f_{SW}} \tag{18}$$

For a 2-V gate threshold MOSFET, the TPS40192's 5-V gate drive, and the TPS40192's 2.5-Ω drive resistance, we estimate a maximum gate-to-drain charge of 8.5 nC. The switching losses of the synchronous rectifier are lower than the switching losses of the main FET because the voltage across the FET at the point of switching is reduced to the forward voltage drop across the body diode of the SR FET and are estimated by using Equation 19.

The conduction losses in the main FET are estimated by the RMS current through the FET times its $R_{DS(on)}$.

$$P_{G1COM} = \left(I_{OUT} \times \frac{1}{12} I_{RIPPLE} \right)^2 \times R_{DS(on)} \times D = I_{L(rms)} \times R_{DS(on)Q1} \times \frac{V_{OUT}}{V_{IN}} \tag{19}$$

Estimating about 40% of total MOSFET losses to be high-side conduction losses, the maximum $R_{DS(on)}$ of the high-side FET can be estimated by using Equation 20.

$$R_{DS(on)Q1} = \frac{P_{Q1C(on)}}{\left(I_{L(rms)} \right)^2 \times \frac{V_{OUT}}{V_{IN}}} \tag{20}$$

For this design with $I_{L_RMS} = 11.22 A_{RMS}$ and 8 V to 1.8 V design, calculate $R_{DS(on)Q1} < 17.3 \text{ m}\Omega$ for our main switching FET.

Estimating 80% of total low-side MOSFET losses in conduction losses, repeat the calculation for the synchronous rectifier, whose losses are dominated by the conduction losses. Calculate the maximum $R_{DS(on)}$ of the synchronous rectifier by Equation 21.

$$R_{DS(on)Q2} = \frac{P_{Q2C(on)}}{\left(I_{L(rms)} \right)^2 \times \left(1 - \frac{V_{OUT}}{V_{IN}} \right)} \tag{21}$$

For this design $I_{L(RMS)} = 10.22 \text{ A}$ at $V_{IN} = 14 \text{ V}$ to 1.8 V $R_{DS(on)Q2(max)} = 8.8 \text{ m}\Omega$.

Table 5. Inductor Requirements $V_{IN} = 4.5 \text{ V}$

PARAMETER	SYMBOL	VALUE	UNITS
High-side MOSFET on-resistance	$R_{DS(on)}$	17.3	mΩ
High-side MOSFET gate-to-drain charge	Q_{GD1}	8.5	nC
Low-side MOSFET on-resistance	$R_{DS(on)Q2}$	8.8	mΩ

The IRF7466 has an $R_{DS(on)MAX}$ of 17 mΩ at 4.5-V gate drive and only 8.0-nC V_{GD} "Miller" charge with a 4.5-V gate drive, and is chosen as a high-side FET. The IRF7834 has an $R_{DS(on)MAX}$ of 5.5 mΩ at 4.5-V gate drive and 44 nC of total gate charge. These two FETs have maximum total gate charges of 23 nC and 44 nC respectively, which draws 40.2-mA from the 5-V regulator, less than its 50-mA minimum rating.

Boot Strap Capacitor

To ensure proper charging of the high-side FET gate, limit the ripple voltage on the boost capacitor to less than 50 mV.

$$C_{\text{BOOST}} = 20 \times Q_{G1} \quad (22)$$

Based on the IRF7466 MOSFET with a gate charge of 23 nC, we calculate minimum of 460 nF of capacitance. The next higher standard value of 470 nF is selected for the bootstrap capacitor.

NOTE

It is recommended to add a high-resistance resistor in parallel with the bootstrap capacitor. Adding a small amount of load to the bootstrap capacitor (100 kΩ for a 100-nF typical capacitor) creates a discharge time constant for the bootstrap voltage following a shutdown event. This prevents the possibility of an inadvertent turn-on of the high-side FET following shutdown via the ENABLE pin, due to leakage paths within the driver stage which can slowly transfer the bootstrap voltage to the HDRV pin following the shutdown. (See [Figure 17](#))

Input Bypass Capacitor (C6)

As suggested the TPS40192/93 datasheet, select a 1.0-μF ceramic bypass capacitor for VDD.

BP5 Bypass Capacitor (C5)

The TPS40192 recommends a minimum 1.0-μF ceramic capacitance to stabilize the 5-V regulator. To limit regulator noise to less than 10 mV, the bypass capacitor is sized by using [Equation 23](#).

$$C_{\text{BP5}} = 100 \times \text{MAX}(Q_{G1}, Q_{G2}) \quad (23)$$

Since Q2 is larger than Q1 and Q2's total gate charge is 44 nC, a BP5 capacitor of 4.4-μF is calculated, and the next larger standard value of 4.7 μF is selected to limit noise on the BP5 regulator.

Input Voltage Filter Resistor (R11)

$V_{\text{IN(min)}} > 6.0 \text{ V}$ so a 0 Ω resistor is placed in the VDD resistor location. If $V_{\text{IN(min)}} < 6.0 \text{ V}$, an optional 1Ω to 2 Ω series VDD resistor could be used to filter switching noise from the device. Limit the voltage drop across this resistor to less than 50 mV.

$$R_{\text{VDD}} < \frac{V_{\text{RVDD(max)}}}{I_{\text{DD}}} = \frac{50 \text{ mV}}{3 \text{ mA} + (Q_{G1}, Q_{G2}) \times f_{\text{SW}}} \quad (24)$$

Driving the two FETs with 23 nC and 44 nC respectively, we calculate a maximum I_{VDD} current of 43 mA and would select a 1-Ω resistor.

Short Circuit Protection (R9)

The TPS40192/93 use the negative drop across the low-side FET during the OFF time to measure the inductor current. The voltage drop across the low-side FET is given by [Equation 25](#).

$$V_{\text{CS}} = I_{\text{L(peak)}} \times R_{\text{DS(on)}} \quad (25)$$

When $8 \text{ V} \leq V_{\text{IN}} \leq 14 \text{ V}$, $I_{\text{L(peak)}} = 11.5 \text{ A}$ Using the IRF7834 MOSFET, we calculate a peak voltage drop of 63.3 mV.

The TPS40192's internal temperature coefficient helps compensate for the MOSFET's $R_{\text{DS(on)}}$ temperature coefficient. For this design select the short circuit protection voltage threshold of 110 mV by selecting R9 = 3.9 kΩ.

Feedback Compensation

Modeling the Power Stage

The DC gain of the modulator is given by [Equation 26](#).

$$A_{MOD} = \frac{dV_{OUT}}{dV_{COMP}} = \frac{dD}{V_{COMP}} \times V_{IN} = \frac{dt}{dV_{RAMP}} \times \frac{1}{T_{SW}} \times V_{IN} \quad (26)$$

Since the peak-to-peak ramp voltage given in the Electrical Characteristics Table is projected from the ramp slope over a full switching period, the modulator gain can be calculated as [Equation 27](#).

$$A_{MOD} = \frac{V_{IN}}{V_{RAMP(p-p)}} \quad (27)$$

This design finds a maximum modulator gain of 14 (23.0 dB). The L-C filter applies a double pole at the resonance frequency described in [Equation 28](#).

$$f_{RES} = \frac{1}{2\pi \times \sqrt{L \times C}} \quad (28)$$

For this design with a 1.0- μ H inductor and 2 100- μ F capacitors, the resonance frequency is approximately 11.3 kHz. At any lower frequency, the power stage has a DC gain of 23 dB and at any higher frequency the power stage gain drops off at -40 dB per decade. The ESR zero is approximated in [Equation 29](#).

$$f_{ESR} = \frac{1}{2\pi \times C_{OUT} \times R_{ESR}} \quad (29)$$

For $C_{OUT} = 2, 100\text{-}\mu\text{F}$ and $R_{ESR} = 2.5\text{ m}\Omega$ each, $f_{ESR} = 636\text{ kHz}$, greater than 1/5th the switching frequency and outside the scope of the error amplifier design. The gain of the power stage would change to -20 dB per decade above f_{ESR} . The straight line approximation the power stage gain is described in [Figure 18](#).

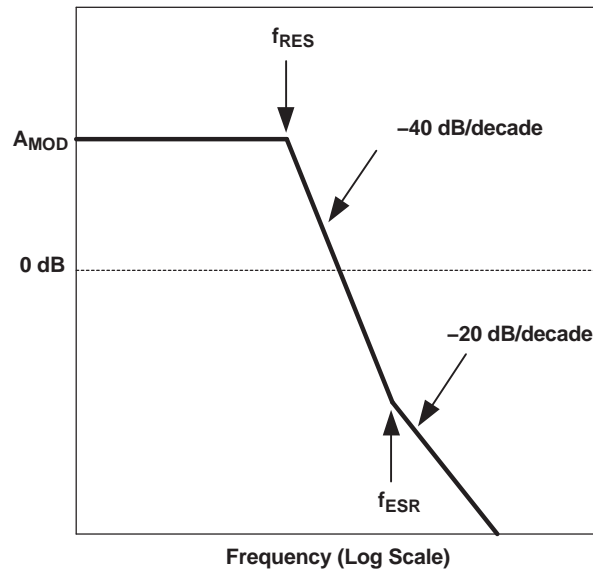

Figure 18. Approximation of Power Stage Gain

The following compensation design procedure assumes $f_{ESR} > f_{RES}$. For designs using large high-ESR bulk capacitors on the output where $f_{ESR} < f_{RES}$. Type-II compensation can be used but is not addressed in this document.

Table 6. Error Amplifier Design Parameters

PARAMETER	SYMBOL	VALUE	UNITS
First zero frequency	F _{Z1}	5.8	kHz
Second zero frequency	F _{Z2}	11.0	
First pole frequency	F _{P1}	60	
Second pole frequency	F _{P2}	500	
Midband gain	A _{MID(band)}	1.86	V/V

Approximate C2 with the formula described in [Equation 32](#).

$$C2 = \frac{1}{2\pi \times R8 \times f_{Z2}} \tag{32}$$

C2 = 1000 pf (A standard capacitor value to calculated 723 pF) and approximate R6 with the formula described in [Equation 33](#).

$$R10 = \frac{1}{2\pi \times C2 \times f_{P1}} \tag{33}$$

R10 = 2.61 kΩ (Closest standard resistor value to calculated 2.65 kΩ) Calculate R3 with [Equation 34](#).

$$R6 = \frac{A_{MID(band)} \times (R10 \times R8)}{R10 + R8} \tag{34}$$

With A_{MID(band)} = 1.86, R10 = 2.61 kΩ and R8 = 20 kΩ , R6 = 4.22 kΩ (Closest standard resistor value to calculated 4.29 kΩ).

Calculate C1 and C3 using [Equation 35](#) and [Equation 36](#).

$$C3 = \frac{1}{2\pi \times R6 \times f_{Z1}} \tag{35}$$

$$C1 = \frac{1}{2\pi \times R6 \times f_{P1}} \tag{36}$$

For R6 = 4.22kΩ , C1 = 100 pF (a standard value close to 75 pF) C3 = 1000 pF (the closest standard value to 7.5 nF) error amplifier straight line approximation transfer function is described in [Figure 20](#).

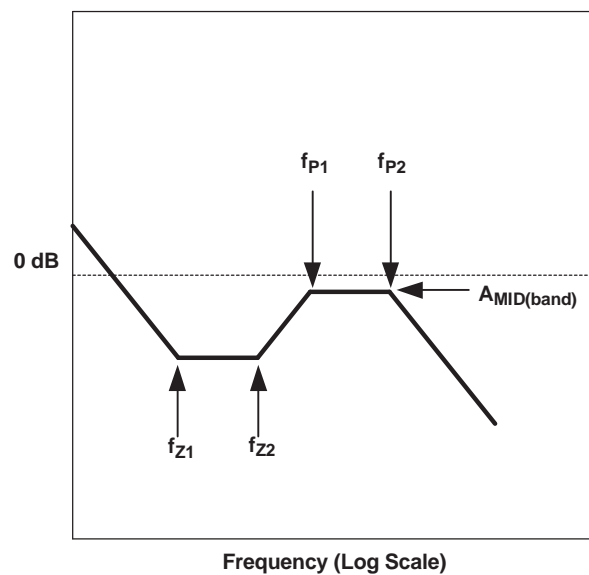

Figure 20. Error Amplifier Transfer Function Approximation

List of Materials
Table 7. List of Materials

QTY	REF DES	Value	Description	Size	Part Number	MFR
1	C1	100 pF	Capacitor, Ceramic, 10V, C0G, 10%	0603	STD	STD
1	C2	1000 pF	Capacitor, Ceramic, 10V, C0G, 10%	0603	STD	STD
1	C3	10 nF	Capacitor, Ceramic, 10V, C0G, 10%	0603	STD	STD
1	C4	1.0 μ F	Capacitor, Ceramic, 25V, X5R, 20%	0805	STD	STD
1	C5	4.7 μ F	Capacitor, Ceramic, 10V, X5R, 20%	0805	STD	STD
1	C6	470 nF	Capacitor, Ceramic, 10V, X5R, 20%	0603	Std	Std
2	C7	10 μ F	Capacitor, Ceramic, 25V, X5R, 20%	1210	C3225X7R1E106M	TDK
2	C8	100 μ F	Capacitor, Ceramic, 6.3V, X5R, 20%	1210	C3225X5R0J107M	TDK
1	C11	1.0 μ F	Capacitor, Ceramic, 6.3V, X5R, 20%	0603	STD	STD
1	L1	1.0 μ H	Inductor, SMT, 1.0- μ F, 6.6 m Ω , 12 A / 17 A	0.268 x 0.268 inch	PG0083.102	Pulse
1	Q1	2N7002W	MOSFET, N-Ch, V_{DS} 60 V, $R_{DS(on)}$ 2 Ω , I_{DD} 115 mA	SOT-323 (SC-70)	2N7002W-7	Diodes Inc
1	Q2	IRF7466	Transistor, MOSFET, N-channel, 30 V, $R_{DS(on)}$ 17 m Ω , 9 A	SO8	IRF7466	IR
1	Q3	IRF7834	Transistor, MOSFET, N-channel, 30 V, $R_{DS(on)}$ 5.5 m Ω , 9 A	SO8	IRF7834	IR
1	R1	5.1 k Ω	Resistor, Chip, 1/16W, 5%	0603	Std	Std
1	R2	2 k Ω	Resistor, Chip, 1/16W, 5%	0603	Std	Std
1	R4	100 k Ω	Resistor, Chip, 1/16W, 1%	0603	Std	Std
1	R6	4.22 k Ω	Resistor, Chip, 1/16W, 1%	0603	Std	Std
1	R7	9.76 k Ω	Resistor, Chip, 1/16W, 1%	0603	Std	Std
1	R8	20 k Ω	Resistor, Chip, 1/16W, 1%	0603	Std	Std
1	R9	3.9 k Ω	Resistor, Chip, 1/16W, 5%	0603	Std	Std
1	R10	2.61 k Ω	Resistor, Chip, 1/16W, 1%	0603	Std	Std
2	R11, R13	0	Resistor, Chip, 1/16W, 5%	0603	Std	Std
2	R12, R14	100 k Ω	Resistor, Chip, 1/16W, 5%	0603	Std	Std
1	U1	TPS40192DRC	Cost Optimized Midrange Input Voltage High-Frequency Synchronous Buck Controller	DRC10	TPS40192DRC	TI

DEFINITION OF SYMBOLS

Table 8. Definition of Symbols

SYMBOL	DESCRIPTION
$V_{IN(max)}$	Maximum Operating Input Voltage
$V_{IN(min)}$	Minimum Operating Input Voltage
$V_{IN(ripple)}$	Peak to Peak AC ripple voltage on V_{IN}
V_{OUT}	Target Output Voltage
$V_{OUT(ripple)}$	Peak to Peak AC ripple voltage on V_{OUT}
$I_{OUT(max)}$	Maximum Operating Load Current
I_{RIPPLE}	Peak-to-Peak ripple current through Inductor
$I_{L(peak)}$	Peak Current through Inductor
$I_{L(rms)}$	Root Mean Squared Current through Inductor
$I_{RMS(Cin)}$	Root Mean Squared Current through Input Capacitor
f_{SW}	Switching Frequency
f_{CO}	Desired Control Loop Crossover frequency
A_{MOD}	Low Frequency Gain of the PWM Modulator ($V_{OUT} / V_{CONTROL}$)
$V_{CONTROL}$	PWM Control Voltage (Error Amplifier Output Voltage V_{COMP})
f_{RES}	L-C Filter Resonant Frequency
f_{ESR}	Output Capacitors' ESR zero Frequency
F_{P1}	First Pole Frequency in Error Amplifier Compensation
F_{P2}	Second Pole Frequency in Error Amplifier Compensation
F_{Z1}	First Zero Frequency in Error Amplifier Compensation
F_{Z2}	Second Pole Frequency in Error Amplifier Compensation
Q_{G1}	Total Gate Charge of Main MOSFET
Q_{G2}	Total Gate Charge of SR MOSFET
$R_{DS(on)Q1}$	"ON" Drain to Source Resistance of Main MOSFET
$R_{DS(on)Q2}$	"ON" Drain to Source Resistance of SR MOSEFT
$P_{Q1C(on)}$	Conduction Losses in Main Switching MOSFET
P_{Q1SW}	Switching Losses in Main Switching MOSFET
$P_{Q2C(on)}$	Conduction Losses in Synchronous Rectifier MOSFET
Q_{GD}	Gate to Drain Charge of Synchronous Rectifier MOSFET
Q_{GS}	Gate to Source Charge of Synchronous Rectifier MOSFET

ADDITIONAL REFERENCES

Related Parts

The following parts have characteristics similar to the TPS40192/3 and may be of interest.

Table 9. Related Parts

DEVICE	DESCRIPTION
TPS40100	Midrange Input Synchronous Controller with Advanced Sequencing and Output Margining
TPS40075	Wide Input Synchronous Controller with Voltage Feed Forward
TPS40190	Low Pin Count Synchronous Buck Controller

References

These references may be found on the web at www.power.ti.com under Technical Documents. Many design tools and links to additional references, including design software, are also found at power.ti.com.

1. *Under The Hood Of Low Voltage DC/DC Converters*, SEM1500 Topic 5, 2002 Seminar Series
2. *Understanding Buck Power Stages in Switchmode Power Supplies*, [SLVA057](#), March 1999
3. *Design and Application Guide for High Speed MOSFET Gate Drive Circuits*, SEM 1400, 2001 Seminar Series
4. *Designing Stable Control Loops*, SEM 1400, 2001 Seminar Series
5. Additional PowerPAD™ information may be found in Applications Briefs SLMA002 and SLMA004
6. QFN/SON PCB Attachment, Texas Instruments Literature Number [SLUA271](#), June 2002

REVISION HISTORY

Changes from Revision B (SEPTEMBER 2007) to Revision C **Page**

- Changed corrected label for pin 8 10
 - Changed corrected waveform 13
-

Changes from Revision C (August 2010) to Revision D **Page**

- Added text to the last paragraph in the Enable Functionality section. 12
-

Changes from Revision D (JULY 2012) to Revision E **Page**

- Added clarity to [Figure 17](#) 19
 - Added note regarding high-resistance resistor. 23
 - Added component R14 to [Table 7](#) 27
-

PACKAGING INFORMATION

Orderable Device	Status (1)	Package Type	Package Drawing	Pins	Package Qty	Eco Plan (2)	Lead/Ball Finish (6)	MSL Peak Temp (3)	Op Temp (°C)	Device Marking (4/5)	Samples
TPS40192DRCCR	ACTIVE	VSON	DRC	10	3000	Green (RoHS & no Sb/Br)	CU NIPDAU	Level-2-260C-1 YEAR	-40 to 85	0192	Samples
TPS40192DRCRG4	ACTIVE	VSON	DRC	10		TBD	Call TI	Call TI	-40 to 85		Samples
TPS40192DRCT	ACTIVE	VSON	DRC	10	250	Green (RoHS & no Sb/Br)	CU NIPDAU	Level-2-260C-1 YEAR	-40 to 85	0192	Samples
TPS40192DRCTG4	ACTIVE	VSON	DRC	10	250	Green (RoHS & no Sb/Br)	CU NIPDAU	Level-2-260C-1 YEAR	-40 to 85	0192	Samples
TPS40193DRCCR	ACTIVE	VSON	DRC	10	3000	Green (RoHS & no Sb/Br)	CU NIPDAU	Level-2-260C-1 YEAR	-40 to 85	0193	Samples
TPS40193DRCRG4	ACTIVE	VSON	DRC	10	3000	Green (RoHS & no Sb/Br)	CU NIPDAU	Level-2-260C-1 YEAR	-40 to 85	0193	Samples
TPS40193DRCT	ACTIVE	VSON	DRC	10	250	Green (RoHS & no Sb/Br)	CU NIPDAU	Level-2-260C-1 YEAR	-40 to 85	0193	Samples
TPS40193DRCTG4	ACTIVE	VSON	DRC	10	250	Green (RoHS & no Sb/Br)	CU NIPDAU	Level-2-260C-1 YEAR	-40 to 85	0193	Samples

(1) The marketing status values are defined as follows:

ACTIVE: Product device recommended for new designs.

LIFEBUY: TI has announced that the device will be discontinued, and a lifetime-buy period is in effect.

NRND: Not recommended for new designs. Device is in production to support existing customers, but TI does not recommend using this part in a new design.

PREVIEW: Device has been announced but is not in production. Samples may or may not be available.

OBSOLETE: TI has discontinued the production of the device.

(2) Eco Plan - The planned eco-friendly classification: Pb-Free (RoHS), Pb-Free (RoHS Exempt), or Green (RoHS & no Sb/Br) - please check <http://www.ti.com/productcontent> for the latest availability information and additional product content details.

TBD: The Pb-Free/Green conversion plan has not been defined.

Pb-Free (RoHS): TI's terms "Lead-Free" or "Pb-Free" mean semiconductor products that are compatible with the current RoHS requirements for all 6 substances, including the requirement that lead not exceed 0.1% by weight in homogeneous materials. Where designed to be soldered at high temperatures, TI Pb-Free products are suitable for use in specified lead-free processes.

Pb-Free (RoHS Exempt): This component has a RoHS exemption for either 1) lead-based flip-chip solder bumps used between the die and package, or 2) lead-based die adhesive used between the die and leadframe. The component is otherwise considered Pb-Free (RoHS compatible) as defined above.

Green (RoHS & no Sb/Br): TI defines "Green" to mean Pb-Free (RoHS compatible), and free of Bromine (Br) and Antimony (Sb) based flame retardants (Br or Sb do not exceed 0.1% by weight in homogeneous material)

(3) MSL, Peak Temp. - The Moisture Sensitivity Level rating according to the JEDEC industry standard classifications, and peak solder temperature.

(4) There may be additional marking, which relates to the logo, the lot trace code information, or the environmental category on the device.

(5) Multiple Device Markings will be inside parentheses. Only one Device Marking contained in parentheses and separated by a "~" will appear on a device. If a line is indented then it is a continuation of the previous line and the two combined represent the entire Device Marking for that device.

(6) Lead/Ball Finish - Orderable Devices may have multiple material finish options. Finish options are separated by a vertical ruled line. Lead/Ball Finish values may wrap to two lines if the finish value exceeds the maximum column width.

Important Information and Disclaimer:The information provided on this page represents TI's knowledge and belief as of the date that it is provided. TI bases its knowledge and belief on information provided by third parties, and makes no representation or warranty as to the accuracy of such information. Efforts are underway to better integrate information from third parties. TI has taken and continues to take reasonable steps to provide representative and accurate information but may not have conducted destructive testing or chemical analysis on incoming materials and chemicals. TI and TI suppliers consider certain information to be proprietary, and thus CAS numbers and other limited information may not be available for release.

In no event shall TI's liability arising out of such information exceed the total purchase price of the TI part(s) at issue in this document sold by TI to Customer on an annual basis.

TAPE AND REEL INFORMATION

QUADRANT ASSIGNMENTS FOR PIN 1 ORIENTATION IN TAPE

*All dimensions are nominal

Device	Package Type	Package Drawing	Pins	SPQ	Reel Diameter (mm)	Reel Width W1 (mm)	A0 (mm)	B0 (mm)	K0 (mm)	P1 (mm)	W (mm)	Pin1 Quadrant
TPS40192DRCR	VSON	DRC	10	3000	330.0	12.4	3.3	3.3	1.1	8.0	12.0	Q2
TPS40192DRCR	VSON	DRC	10	3000	330.0	12.4	3.3	3.3	1.0	8.0	12.0	Q2
TPS40192DRCT	VSON	DRC	10	250	180.0	12.4	3.3	3.3	1.1	8.0	12.0	Q2
TPS40193DRCR	VSON	DRC	10	3000	330.0	12.4	3.3	3.3	1.1	8.0	12.0	Q2
TPS40193DRCR	VSON	DRC	10	3000	330.0	12.4	3.3	3.3	1.0	8.0	12.0	Q2
TPS40193DRCT	VSON	DRC	10	250	180.0	12.4	3.3	3.3	1.1	8.0	12.0	Q2

TAPE AND REEL BOX DIMENSIONS

*All dimensions are nominal

Device	Package Type	Package Drawing	Pins	SPQ	Length (mm)	Width (mm)	Height (mm)
TPS40192DRCR	VSON	DRC	10	3000	367.0	367.0	35.0
TPS40192DRCR	VSON	DRC	10	3000	370.0	355.0	55.0
TPS40192DRCT	VSON	DRC	10	250	210.0	185.0	35.0
TPS40193DRCR	VSON	DRC	10	3000	367.0	367.0	35.0
TPS40193DRCR	VSON	DRC	10	3000	370.0	355.0	55.0
TPS40193DRCT	VSON	DRC	10	250	210.0	185.0	35.0

DRC (S-PVSON-N10)

PLASTIC SMALL OUTLINE NO-LEAD

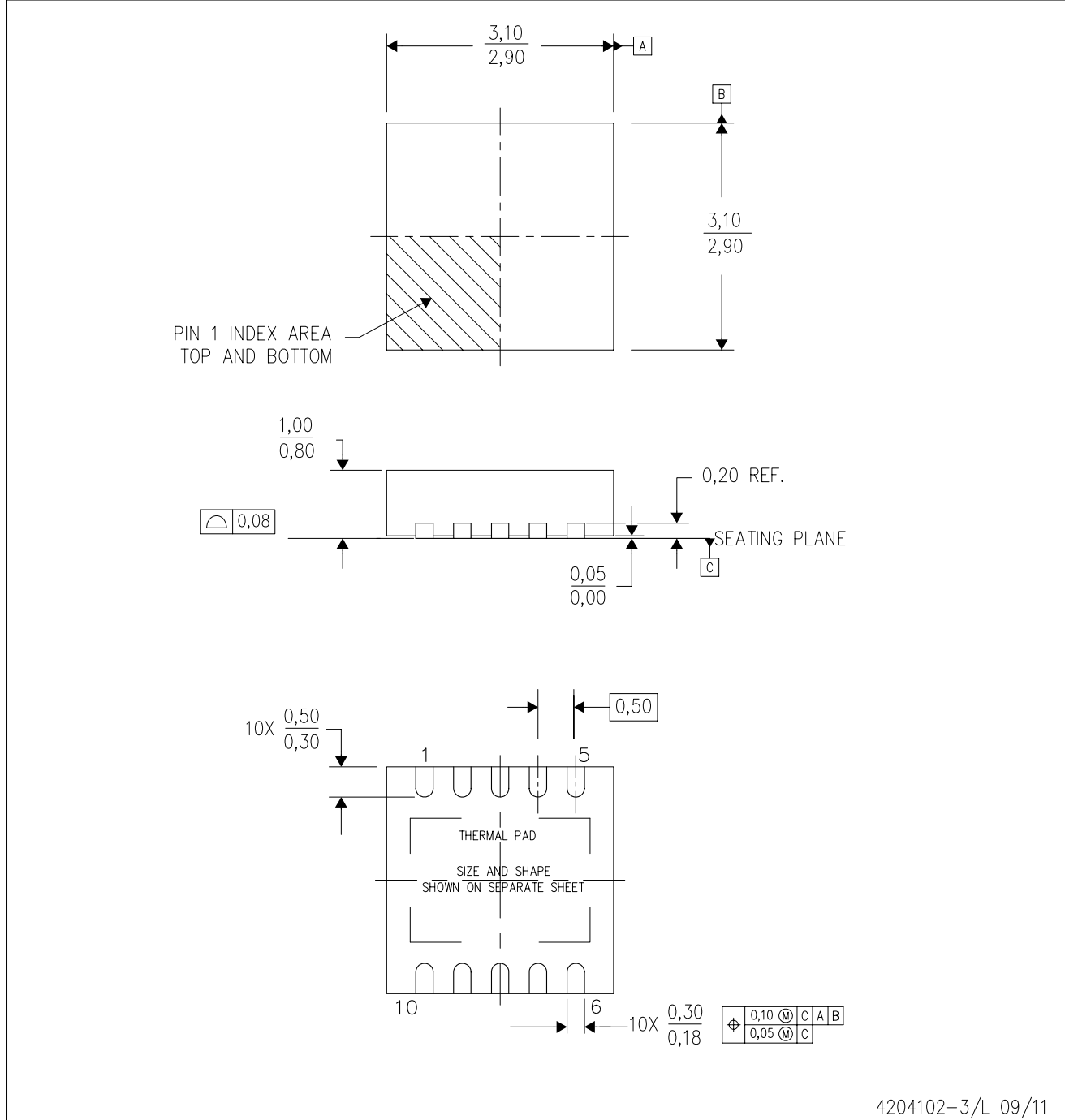

4204102-3/L 09/11

- NOTES:
- All linear dimensions are in millimeters. Dimensioning and tolerancing per ASME Y14.5M-1994.
 - This drawing is subject to change without notice.
 - Small Outline No-Lead (SON) package configuration.
 - The package thermal pad must be soldered to the board for thermal and mechanical performance, if present.
 - See the additional figure in the Product Data Sheet for details regarding the exposed thermal pad features and dimensions, if present

THERMAL PAD MECHANICAL DATA

DRC (S-PVSON-N10)

PLASTIC SMALL OUTLINE NO-LEAD

THERMAL INFORMATION

This package incorporates an exposed thermal pad that is designed to be attached directly to an external heatsink. The thermal pad must be soldered directly to the printed circuit board (PCB). After soldering, the PCB can be used as a heatsink. In addition, through the use of thermal vias, the thermal pad can be attached directly to the appropriate copper plane shown in the electrical schematic for the device, or alternatively, can be attached to a special heatsink structure designed into the PCB. This design optimizes the heat transfer from the integrated circuit (IC).

For information on the Quad Flatpack No-Lead (QFN) package and its advantages, refer to Application Report, QFN/SON PCB Attachment, Texas Instruments Literature No. SLUA271. This document is available at www.ti.com.

The exposed thermal pad dimensions for this package are shown in the following illustration.

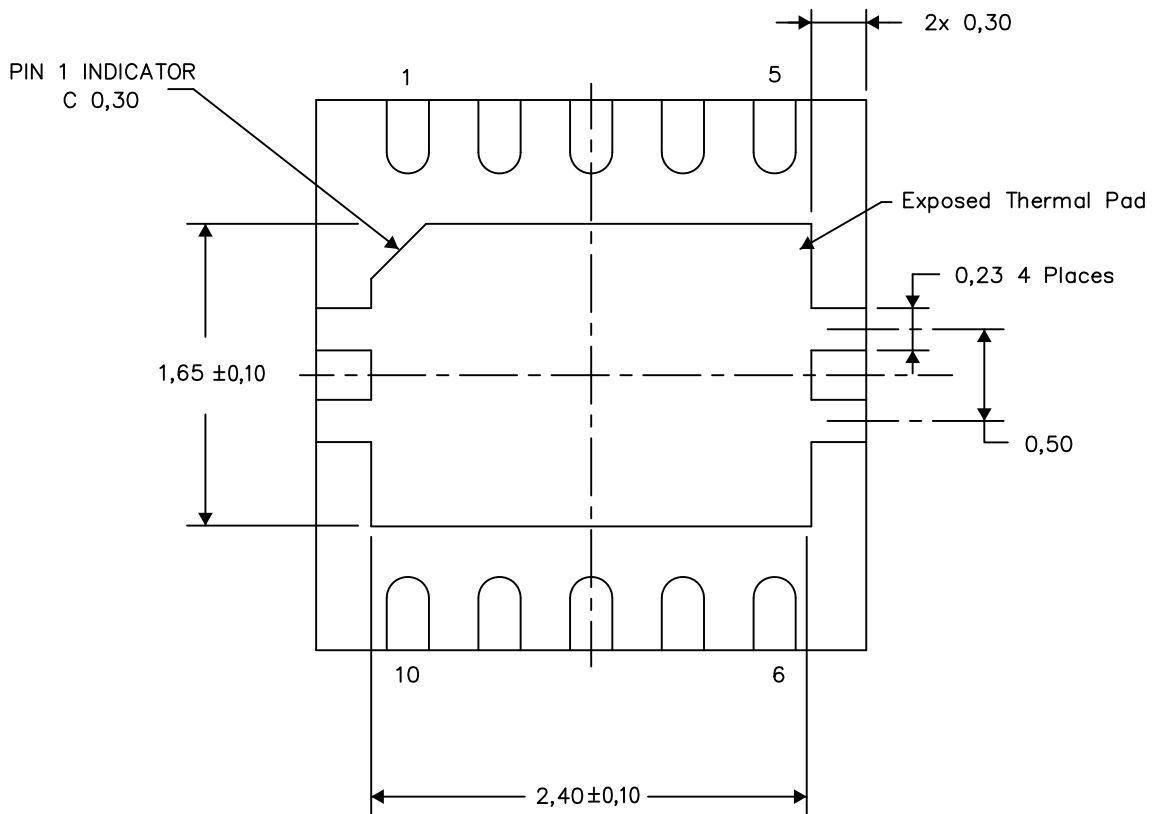

Bottom View

Exposed Thermal Pad Dimensions

4206565-3/X 07/15

NOTE: A. All linear dimensions are in millimeters

IMPORTANT NOTICE

Texas Instruments Incorporated and its subsidiaries (TI) reserve the right to make corrections, enhancements, improvements and other changes to its semiconductor products and services per JESD46, latest issue, and to discontinue any product or service per JESD48, latest issue. Buyers should obtain the latest relevant information before placing orders and should verify that such information is current and complete. All semiconductor products (also referred to herein as "components") are sold subject to TI's terms and conditions of sale supplied at the time of order acknowledgment.

TI warrants performance of its components to the specifications applicable at the time of sale, in accordance with the warranty in TI's terms and conditions of sale of semiconductor products. Testing and other quality control techniques are used to the extent TI deems necessary to support this warranty. Except where mandated by applicable law, testing of all parameters of each component is not necessarily performed.

TI assumes no liability for applications assistance or the design of Buyers' products. Buyers are responsible for their products and applications using TI components. To minimize the risks associated with Buyers' products and applications, Buyers should provide adequate design and operating safeguards.

TI does not warrant or represent that any license, either express or implied, is granted under any patent right, copyright, mask work right, or other intellectual property right relating to any combination, machine, or process in which TI components or services are used. Information published by TI regarding third-party products or services does not constitute a license to use such products or services or a warranty or endorsement thereof. Use of such information may require a license from a third party under the patents or other intellectual property of the third party, or a license from TI under the patents or other intellectual property of TI.

Reproduction of significant portions of TI information in TI data books or data sheets is permissible only if reproduction is without alteration and is accompanied by all associated warranties, conditions, limitations, and notices. TI is not responsible or liable for such altered documentation. Information of third parties may be subject to additional restrictions.

Resale of TI components or services with statements different from or beyond the parameters stated by TI for that component or service voids all express and any implied warranties for the associated TI component or service and is an unfair and deceptive business practice. TI is not responsible or liable for any such statements.

Buyer acknowledges and agrees that it is solely responsible for compliance with all legal, regulatory and safety-related requirements concerning its products, and any use of TI components in its applications, notwithstanding any applications-related information or support that may be provided by TI. Buyer represents and agrees that it has all the necessary expertise to create and implement safeguards which anticipate dangerous consequences of failures, monitor failures and their consequences, lessen the likelihood of failures that might cause harm and take appropriate remedial actions. Buyer will fully indemnify TI and its representatives against any damages arising out of the use of any TI components in safety-critical applications.

In some cases, TI components may be promoted specifically to facilitate safety-related applications. With such components, TI's goal is to help enable customers to design and create their own end-product solutions that meet applicable functional safety standards and requirements. Nonetheless, such components are subject to these terms.

No TI components are authorized for use in FDA Class III (or similar life-critical medical equipment) unless authorized officers of the parties have executed a special agreement specifically governing such use.

Only those TI components which TI has specifically designated as military grade or "enhanced plastic" are designed and intended for use in military/aerospace applications or environments. Buyer acknowledges and agrees that any military or aerospace use of TI components which have **not** been so designated is solely at the Buyer's risk, and that Buyer is solely responsible for compliance with all legal and regulatory requirements in connection with such use.

TI has specifically designated certain components as meeting ISO/TS16949 requirements, mainly for automotive use. In any case of use of non-designated products, TI will not be responsible for any failure to meet ISO/TS16949.

Products

Audio	www.ti.com/audio
Amplifiers	amplifier.ti.com
Data Converters	dataconverter.ti.com
DLP® Products	www.dlp.com
DSP	dsp.ti.com
Clocks and Timers	www.ti.com/clocks
Interface	interface.ti.com
Logic	logic.ti.com
Power Mgmt	power.ti.com
Microcontrollers	microcontroller.ti.com
RFID	www.ti-rfid.com
OMAP Applications Processors	www.ti.com/omap
Wireless Connectivity	www.ti.com/wirelessconnectivity

Applications

Automotive and Transportation	www.ti.com/automotive
Communications and Telecom	www.ti.com/communications
Computers and Peripherals	www.ti.com/computers
Consumer Electronics	www.ti.com/consumer-apps
Energy and Lighting	www.ti.com/energy
Industrial	www.ti.com/industrial
Medical	www.ti.com/medical
Security	www.ti.com/security
Space, Avionics and Defense	www.ti.com/space-avionics-defense
Video and Imaging	www.ti.com/video

TI E2E Community

e2e.ti.com