

TPS5615, TPS5618, TPS5625, TPS5633 SYNCHRONOUS-BUCK HYSTERETIC REGULATOR CONTROLLER

SLVS177B – SEPTEMBER 1998 – REVISED JULY 2000

- $\pm 1\%$ Reference Over Full Operating Temperature Range
- Synchronous Rectifier Driver for $>90\%$ Efficiency
- Fixed Output Voltage Options of 1.5 V, 1.8 V, 2.5 V, and 3.3 V
- User-Selectable Hysteretic-Type Control
- Low Supply Current . . . 3 mA Typ
- 11.4-V to 13-V Input Voltage Range, V_{CC}
- Power Good Output
- Programmable Soft-Start
- Overvoltage/Overcurrent Protection
- Active Deadtime Control

PWP PACKAGE
(TOP VIEW)

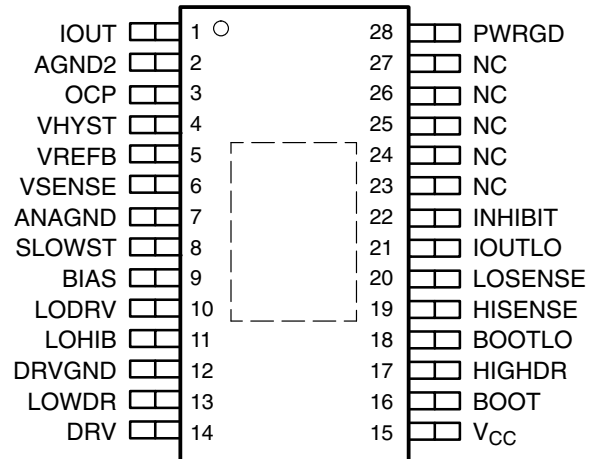

NC – No internal connection

description

The TPS5615 family of synchronous-buck regulator controllers provides an accurate supply voltage to DSPs. The output voltage is internally set by a resistive divider with an accuracy of 1% over the full operating temperature range. A hysteretic controller with user-selectable hysteresis is used to dramatically reduce overshoot and undershoot caused by load transients. Propagation delay from the comparator inputs to the output drivers is less than 250 ns. Overcurrent shutdown and crossover protection for the output drivers combine to eliminate destructive faults in the output FETs. PWRGD monitors the output voltage and pulls the open-collector output low when the output drops below 93% of the nominal output voltage. An overvoltage circuit disables the output drivers if the output voltage rises 15% above the nominal value. The inhibit pin can be used to control power sequencing. Inhibit and undervoltage lockout assures that the 12-V supply voltage and system supply voltage (5 V or 3.3 V) are within proper operating limits before the controller starts. The output driver circuits include 2-A drivers with internal 8-V gate-voltage regulators that can easily provide sufficient power for today's high-powered DSPs. The high-side driver can be configured either as a ground-referenced driver or as a floating bootstrap driver. The TPS5615 family is available in a 28-pin TSSOP PowerPad™ package. It operates over a junction temperature range of 0°C to 125°C.

AVAILABLE OPTIONS

T_J	OUTPUT VOLTAGE	PACKAGE
		TSSOP† (PWP)
0°C to 125°C	1.5 V	TPS5615PWP
	1.8 V	TPS5618PWP
	2.5 V	TPS5625PWP
	3.3 V	TPS5633PWP

† The PWP package is available taped and reeled. Add R suffix to device type (e.g., TPS5615PWPR).



Please be aware that an important notice concerning availability, standard warranty, and use in critical applications of Texas Instruments semiconductor products and disclaimers thereto appears at the end of this data sheet.

PowerPAD is a trademark of Texas Instruments Incorporated.

PRODUCTION DATA information is current as of publication date. Products conform to specifications per the terms of Texas Instruments standard warranty. Production processing does not necessarily include testing of all parameters.



POST OFFICE BOX 655303 • DALLAS, TEXAS 75265

Copyright © 2000, Texas Instruments Incorporated

TPS5615, TPS5618, TPS5625, TPS5633 SYNCHRONOUS-BUCK HYSTERETIC REGULATOR CONTROLLER

SLVS177B – SEPTEMBER 1998 – REVISED JULY 2000

functional block diagram

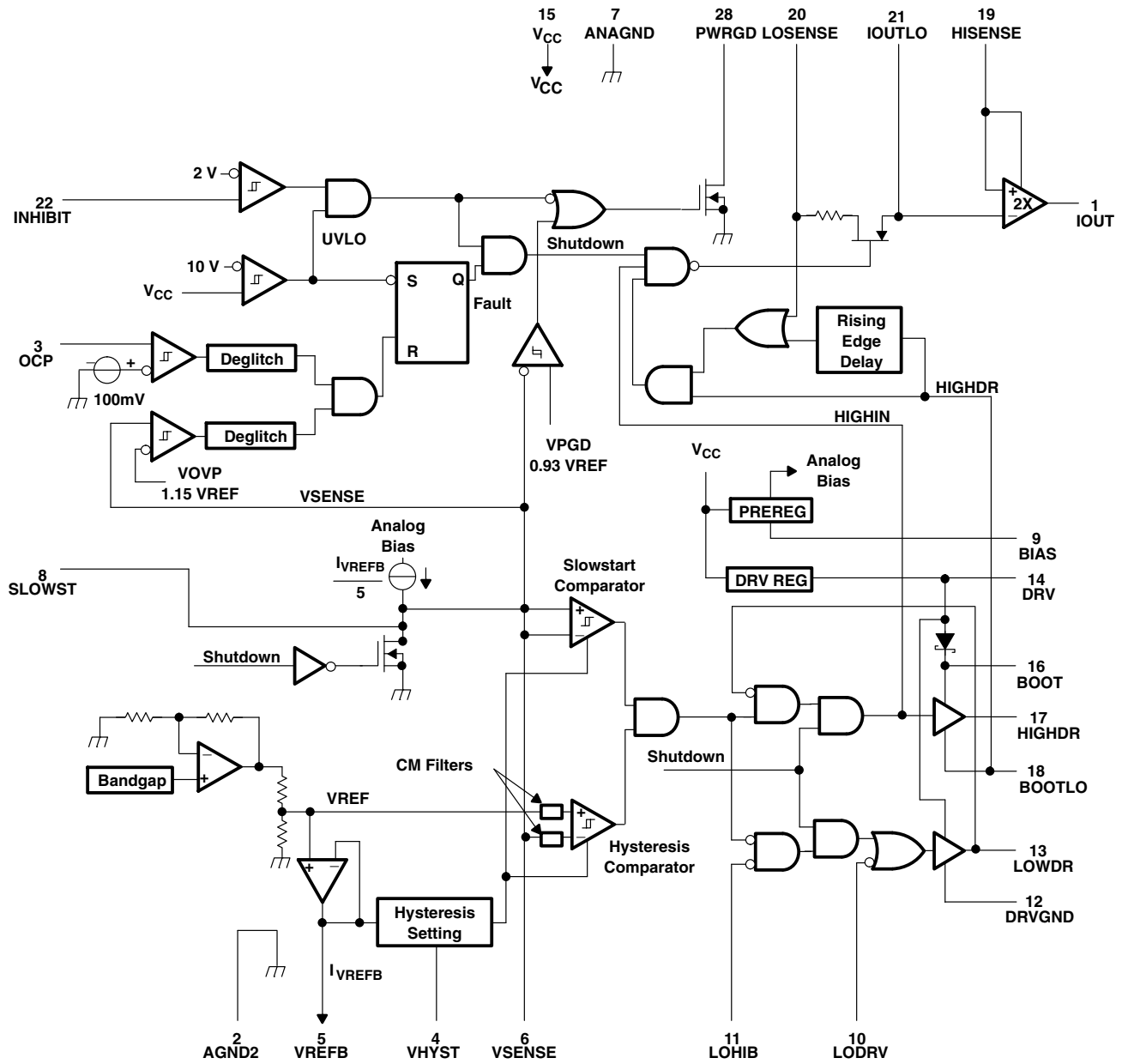

TPS5615, TPS5618, TPS5625, TPS5633 SYNCHRONOUS-BUCK HYSTERETIC REGULATOR CONTROLLER

SLVS177B – SEPTEMBER 1998 – REVISED JULY 2000

Terminal Functions

TERMINAL NAME	NO.	I/O	DESCRIPTION
AGND2	2		Analog ground (must be connected).
ANAGND	7		Analog ground
BIAS	9		Analog bias pin. A 1- μ F capacitor should be connected from BIAS to ANAGND.
BOOT	16		Bootstrap. A 1- μ F capacitor should be connected from BOOT to BOOTLO.
BOOTLO	18		Bootstrap low. Connect to the junction of the high-side and low-side FETs for floating drive configuration. Connect to PGND for ground-reference drive configuration.
DRV	14		Drive regulator for the FET drivers. A 1- μ F capacitor should be connected from DRV to DRVGND.
DRVGND	12		Drive ground. Ground for FET drivers. Connect to FET PWRGND.
HIGHDR	17		High drive. Output drive to high-side power switching FETs.
HISENSE	19		High current sense. For current sensing across high-side FETs, connect to the drain of the high-side FETs; for optional current sensing scheme, connect to power supply side of current-sense resistor placed in series with high-side FET drain.
INHIBIT	22		Disables the drive signals to the MOSFET drivers. Also serves as UVLO for system logic supply (3.3 V or 5 V). An external pullup resistor should be connected to system-logic supply.
IOUT	1		Current out. Output voltage on this terminal is proportional to the load current as measured across the $R_{ds(on)}$ of the high side FET. The voltage on this terminal equals $2 \times R_{DS(ON)} \times I_{OUT}$. In applications where very accurate current-sensing is required, a sense resistor should be connected between the input supply and the drain of the high-side FETs.
IOUTLO	21		Current sense low output. This is the voltage on the LOSENSE terminal when the high-side FETs are on. A ceramic capacitor (between 0.033 μ F and 0.1 μ F) should be connected from IOUTLO to HISENSE to hold the sensed voltage.
LODRV	10		Low drive enable. Normally tied to 5 V. To configure the low-side FET as a crowbar, pull LODRV low.
LOHIB	11		Low side inhibit. Connect to the junction of the high- and low-side FETs to control the anti-cross-conduction and eliminate shoot-through current. Disabled when configured in crowbar mode.
LOSENSE	20		Low current sense. For current sensing across high-side FETs, connect to the source of the high-side FETs; for optional current sensing scheme, connect to high-side FET drain side of current-sense resistor placed in series with high-side FET drain.
LOWDR	13		Low drive. Output drive to synchronous rectifier FETs.
NC	23–27		No connect
OCP	3		Over current protection. Current limit trip point is set with a resistor divider between IOUT and ANAGND.
PWRGD	28		Power good. PWRGD signal goes high when output voltage is within 7% of voltage setpoint. Open-drain output.
SLOWST	8		Slow Start (soft start). A capacitor from SLOWST to ANAGND sets the slowstart time. Slowstart current = $I_{VREFB}/5$
VHYST	4		Hysteresis set input. The hysteresis is set with a resistor divider from VREFB to ANAGND. Hysteresis = $2 \times (V_{REFB} - V_{HYST})$
V _{CC}	15		12-V supply. A 1- μ F capacitor should be connected from V _{CC} to DRVGND.
VREFB	5		Buffered reference voltage
VSENSE	6		Voltage sense Input. To be connected from converter output voltage bus to sense and control output voltage. It is recommended that a RC low-pass filter be connected at this pin to filter noise.



TPS5615, TPS5618, TPS5625, TPS5633 SYNCHRONOUS-BUCK HYSTERETIC REGULATOR CONTROLLER

SLVS177B – SEPTEMBER 1998 – REVISED JULY 2000

detailed description

Vref

The reference voltage section consists of a temperature-compensated bandgap reference and a resistive divider that sets the output voltage option. The output voltage, VREF, is within 1% of the nominal setting over the full junction temperature range of 0°C to 125°C, and a V_{CC} supply voltage range of 11.4 V to 12.6 V. The output of the reference network is indirectly brought out through a buffer to the VREFB pin. The voltage on this pin will be within 2% of VREF. It is not recommended to drive loads with VREFB, other than setting the hysteresis of the hysteretic comparator, because the current drawn from VREFB sets the charging current for the slowstart capacitor. Refer to the *slowstart* section for additional information.

hysteretic comparator

The hysteretic comparator regulates the output voltage of the synchronous-buck converter. The hysteresis is set by 2 external resistors and is centered on VREF. The 2 external resistors form a resistor divider from VREFB to ANAGND, with the output voltage connecting to the VHYST pin. The hysteresis of the propagation delay from the comparator inputs to the driver outputs is 250 ns (maximum). The maximum hysteresis setting is 60 mV.

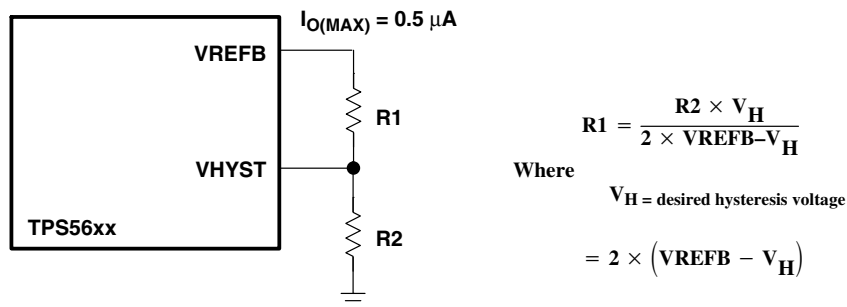

Figure 1. Setting the Hysteresis Voltage

low-side driver

The low-side driver is designed to drive low-R_{ds(on)} n-channel MOSFETs. The current rating of the driver is 2 A, source or sink. The bias to the low-side driver is internally connected to the DRV regulator.

high-side driver

The high-side driver is designed to drive low-R_{ds(on)} n-channel MOSFETs. The current rating of the driver is 2 A, source or sink. The high-side driver can be configured either as a ground-referenced driver or as a floating bootstrap driver. When configured as a floating driver, the bias voltage to the driver is developed from the DRV regulator. The internal bootstrap diode, connected between the DRV and BOOT pins, is a Schottky for improved drive efficiency. The maximum voltage that can be applied between BOOT and DRV_{GND} is 30 V. The driver can be referenced to ground by connecting BOOT_{LO} to DRV_{GND}, and connecting BOOT to either DRV or V_{CC}.

deadtime control

Deadtime control prevents shoot-through current from flowing through the main power FETs during switching transitions by actively controlling the turn-on times of the MOSFET drivers. The high-side driver is not allowed to turn on until the gate-drive voltage to the low-side FET is below 2 V; the low-side driver is not allowed to turn on until the voltage at the junction of the 2 FETs (V_{phase}) is below 2 V.

detailed description (continued)

current sensing

Current sensing is achieved by sampling and holding the voltage across the high-side power FET while the high-side FET is on. The sampling network consists of an internal 60-Ω switch and an external ceramic hold capacitor. Recommended value of the hold capacitor is between 0.033 μF and 0.1 μF. The actual value should give a time constant (60 Ω × C_H) greater than the FET on time. Internal logic controls the turn-on and turn-off of the sample/hold switch such that the switch does not turn on until the V_{phase} voltage transitions high, and the switch turns off when the input to the high-side driver goes low. Thus sampling will occur only when the high side FET is conducting current. The voltage on the IOUT pin equals 2 times the sensed high-side voltage. In applications where a higher accuracy in current-sensing is required, a sense resistor can be placed in series with the high-side FET and the voltage across the sense resistor can be sampled by the current sensing circuit. See Figures 2 and 3.

overcurrent protection

The overcurrent protection (OCP) circuit monitors the current through the high-side FET. The overcurrent threshold is adjustable with an external resistor divider between IOUT and ANAGND, with the divider voltage connected to OCP. If the voltage on OCP (V_S) exceeds 100 mV, then a fault latch is set and the output drivers are turned off. The latch will remain set until V_{CC} goes below the undervoltage lockout value. A 3-μs deglitch timer is included for noise immunity. The OCP circuit is also designed to protect the high-side power FET against a short-to-ground fault on the terminal common to both power FETs (V_{phase}).

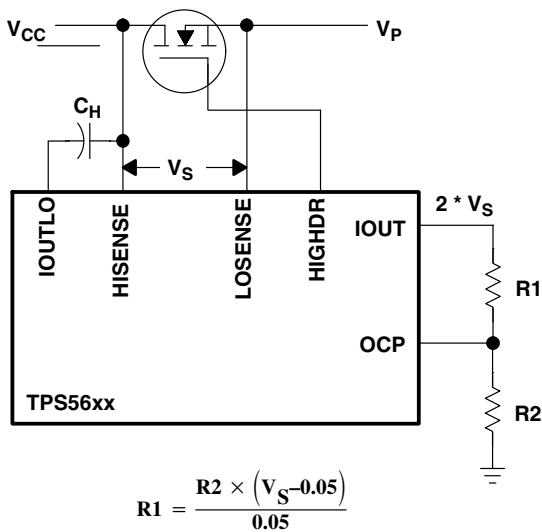

Figure 2. OCP Using FET ON-Resistance

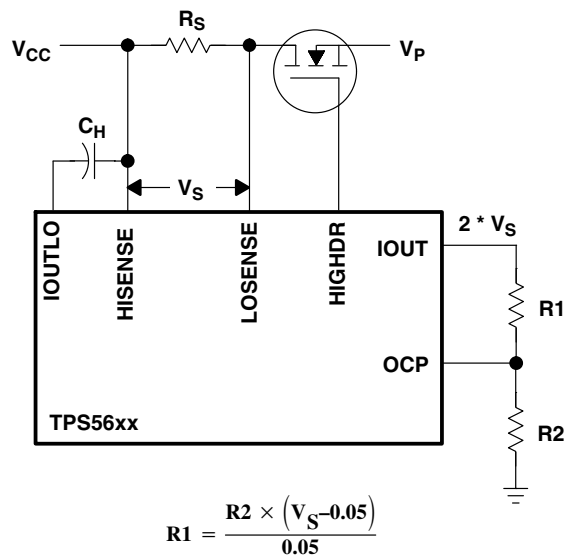

Figure 3. Precision OCP Using External Resistor

inhibit

INHIBIT is a TTL-compatible digital input used to enable the controller. When INHIBIT is low, the output drivers are low and the slowstart capacitor is discharged. When INHIBIT goes high, the short across the slowstart capacitor is released and normal converter operation begins. When the system-logic supply is connected to INHIBIT, it also controls power sequencing by locking out controller operation until the system-logic supply exceeds the input threshold voltage of the inhibit circuit. Thus the 12-V supply and the system-logic supply (either 5 V or 3.3 V) must be above UVLO thresholds before the controller is allowed to start up. The INHIBIT comparator start threshold is 2.1 V and the hysteresis is 100 mV.

TPS5615, TPS5618, TPS5625, TPS5633 SYNCHRONOUS-BUCK HYSTERETIC REGULATOR CONTROLLER

SLVS177B – SEPTEMBER 1998 – REVISED JULY 2000

detailed description (continued)

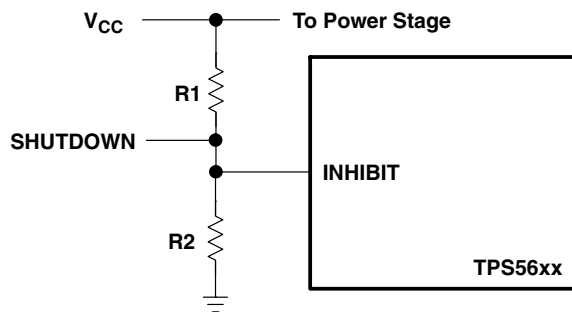

$$R2 = \frac{2.1 \times R1}{V_{TRIP} - 2.1}$$

Where

V_{TRIP} = desired V_{SUPPLY} trip voltage

Figure 4. Input Undervoltage Lockout Circuit Using INHIBIT

V_{CC} undervoltage lockout (UVLO)

The undervoltage lockout circuit disables the controller while the V_{CC} supply is below the 10-V start threshold during power up. While the controller is disabled, the output drivers will be low and the slowstart capacitor will be shorted. When V_{CC} exceeds the start threshold, the short across the slowstart capacitor is released and normal converter operation begins. There is a 2-V hysteresis in the undervoltage lockout circuit for noise immunity.

slowstart

The slowstart circuit controls the rate at which V_O powers up. A capacitor is connected between SLOWST and ANAGND and is charged by an internal current source. The slowstart charging current is determined by the following equation:

$$I_{SLOWSTART} = \frac{I(VREFB)}{5}$$

where $I(VREFB)$ is the current flowing out of $VREFB$. It is recommended that no additional loads be connected to $VREFB$, other than the resistor divider for setting the hysteresis voltage. The maximum current that can be sourced by the $VREFB$ circuit is 500 μ A. The slowstart time is set by:

$$t_{SLOWSTART} = 5 \times C_{SLOWST} \times R_{VREFB}$$

where R_{VREFB} is the total external resistance from $VREFB$ to ANAGND.

power good

The power good circuit monitors for an undervoltage condition on V_O . If V_O is 7% below V_{REF} , then $PWRGD$ is pulled low. $PWRGD$ is an open-drain output.

overvoltage protection

The overvoltage protection (OVP) circuit monitors V_O for an overvoltage condition. If V_O is 15% above V_{REF} , then a fault latch is set and both output drivers are turned off. The latch will remain set until V_{CC} goes below the undervoltage lockout value. A 3- μ s deglitch timer is included for noise immunity. Refer to the LODRV section for information on how to protect the load against overvoltages due to a shorted fault across the high-side power FET.

TPS5615, TPS5618, TPS5625, TPS5633 SYNCHRONOUS-BUCK HYSTERETIC REGULATOR CONTROLLER

SLVS177B – SEPTEMBER 1998 – REVISED JULY 2000

detailed description (continued)

drive regulator

The drive regulator provides drive voltage to the output drivers. The minimum drive voltage is 7 V. The minimum short circuit current is 100 mA. Connect a 1- μ F ceramic capacitor from DRV to DRVGND.

LODRV

The LODRV circuit is designed to protect the load against overvoltages that occur if the high-side FETs become shorted. External components to sense an overvoltage condition are required to use this feature. When an overvoltage fault occurs, LODRV is pulled low and the low-side FET will be turned on, overriding all control signals inside the TPS56xx controller. The crowbar action will short the system-logic supply to ground through the faulted high-side FETs and the low-side FETs. A fuse, in series with V_{IN} , should be added to disconnect the short circuit.

absolute maximum ratings over operating free-air temperature (unless otherwise noted)[†]

Supply voltage range, V_{CC} (see Note 1)	-0.3 to 14 V
Input voltage range: BOOT to DRVGND (high-side driver ON)	-0.3 to 30 V
BOOT to HIGHDRV	-0.3 to 15 V
BOOT to BOOTLO	-0.3 to 15 V
INHIBIT, LODRV	-0.3 to 7.3 V
PWRGD, OCP	-0.3 to 7 V
LOHIB, LOSENSE, IOUTLO, HISENSE	-0.3 to 14 V
VSENSE	-0.3 to 5 V
Voltage difference between ANAGND and DRVGND	± 0.5 V
Output current, VREFB	0.5 mA
Short circuit duration, DRV	Continuous
Continuous total power dissipation	See Dissipation Rating Table
Operating junction temperature range, T_J	0°C to 125°C
Storage temperature range, T_{stg}	-65°C to 150°C
Lead temperature soldering 1,6 mm (1/16 inch) from case for 10 seconds	260°C

[†] Stresses beyond those listed under “absolute maximum ratings” may cause permanent damage to the device. These are stress ratings only, and functional operation of the device at these or any other conditions beyond those indicated under “recommended operating conditions” is not implied. Exposure to absolute-maximum-rated conditions for extended periods may affect device reliability.

NOTE 1: Unless otherwise specified, all voltages are with respect to ANAGND.

DISSIPATION RATING TABLE

PACKAGE	$T_A \leq 25^\circ\text{C}$ POWER RATING	DERATING FACTOR ABOVE $T_A = 25^\circ\text{C}$	$T_A = 70^\circ\text{C}$ POWER RATING	$T_A = 85^\circ\text{C}$ POWER RATING
PWP	1150 mW	11.5 mW/°C	630 mW	460 mW

TPS5615, TPS5618, TPS5625, TPS5633 SYNCHRONOUS-BUCK HYSTERETIC REGULATOR CONTROLLER

SLVS177B – SEPTEMBER 1998 – REVISED JULY 2000

recommended operating conditions

		MIN	MAX	UNIT
Supply voltage, V_{CC}		11.4	13	V
Input voltage	BOOT to DRVND	0	28	V
	BOOT to BOOTLO	0	13	
	INHIBIT, LODRV, PWRGD, OCP	0	6	
	LOHIB, LOSENSE, IOUTLO, HISENSE	0	13	
	VSENSE	0	4.5	
Voltage difference between ANAGND and DRVND		0	±0.2	V
Output current, V_{REFB}^\dagger		0	0.4	mA

† Not recommended to load V_{REFB} other than to set hysteresis since $I_{V_{REFB}}$ sets slowstart time.

electrical characteristics over recommended operating virtual junction temperature range, $V_{CC} = 12\text{ V}$, $I_{DRV} = 0\text{ A}$ (unless otherwise noted)

reference

PARAMETER		TEST CONDITIONS	MIN	TYP	MAX	UNIT
VREF	Reference voltage	$V_{CC} = 11.4\text{ V to }12.6\text{ V}$	1.485		1.515	V
			1.782		1.818	
			2.475		2.525	
			3.267		3.333	
VREFB	Output voltage	$I_{REFB} = 50\ \mu\text{A}$	$V_{REF} - 2\%$	V_{REF}	$V_{REF} + 2\%$	V
VREFB	Output regulation	$10\ \mu\text{A} \leq I_O \leq 500\ \mu\text{A}$	2			mV

power good

PARAMETER		TEST CONDITIONS	MIN	TYP	MAX	UNIT
Undervoltage trip threshold			90	93	95	%VREF
Low-level output voltage, PWRGD		$I_O = 5\text{ mA}$		0.5	0.75	V
High-level input current, PWRGD		$V_{PWRGD} = 6\text{ V}$		1		μA
Hysteresis				10		mV

overvoltage protection

PARAMETER		TEST CONDITIONS	MIN	TYP	MAX	UNIT
Overvoltage trip threshold			112	115	120	%VREF
Hysteresis		See Note 2		10		mV

NOTE 2: Ensured by design, not tested.

slowstart

PARAMETER		TEST CONDITIONS	MIN	TYP	MAX	UNIT
Charge current		$V_{SLOWST} = 0.5\text{ V}$, $I_{V_{REFB}} = 65\ \mu\text{A}$	10.4	13	15.6	μA
Discharge current		$V_{SOFTST} = 1\text{ V}$		3		mA
Comparator input offset voltage					10	mV
Comparator input bias current		See Note 2		10	100	nA
Hysteresis			-7.5		7.5	mV

NOTE 2: Ensured by design, not tested.



TPS5615, TPS5618, TPS5625, TPS5633 SYNCHRONOUS-BUCK HYSTERETIC REGULATOR CONTROLLER

SLVS177B – SEPTEMBER 1998 – REVISED JULY 2000

electrical characteristics over recommended operating virtual junction temperature range,
 $V_{CC} = 12\text{ V}$, $I_{DRV} = 0\text{ A}$ (unless otherwise noted) (continued)

inhibit

PARAMETER	TEST CONDITIONS	MIN	TYP	MAX	UNIT
Startup threshold		1.9	2.1	2.35	V
Hysteresis		0.08	0.1	0.12	V
Stop threshold		1.85			V

input undervoltage lockout

PARAMETER	TEST CONDITIONS	MIN	TYP	MAX	UNIT
Startup threshold		9.25	10	10.75	V
Hysteresis		1.9	2	2.2	V
Stop threshold		7.5			V

hysteretic comparator

PARAMETER	TEST CONDITIONS	MIN	TYP	MAX	UNIT
Input offset voltage		-2.5		2.5	mV
Input bias current	See Note 2			500	nA
Hysteresis accuracy	$V_{REFB} - V_{HYST} = 15\text{ mV}$, (hysteresis window = 30 mV)	-3.5		3.5	mV
Maximum hysteresis setting	$V_{REFB} - V_{HYST} = 30\text{ mV}$		60		mV

NOTE 2: Ensured by design, not tested.

overcurrent protection

PARAMETER	TEST CONDITIONS	MIN	TYP	MAX	UNIT
OCP trip threshold		90	100	110	mV
Input bias current				100	nA



TPS5615, TPS5618, TPS5625, TPS5633 SYNCHRONOUS-BUCK HYSTERETIC REGULATOR CONTROLLER

SLVS177B – SEPTEMBER 1998 – REVISED JULY 2000

electrical characteristics over recommended operating virtual junction temperature range,
 $V_{CC} = 12\text{ V}$, $I_{DRV} = 0\text{ A}$ (unless otherwise noted) (continued)

high-side VDS sensing

PARAMETER	TEST CONDITIONS	MIN	TYP	MAX	UNIT
Gain			2		V/V
Initial accuracy	$V_{HISENSE} = 12\text{ V}$, $V_{LOSENSE} = 11.9\text{ V}$ Differential input to Vds sensing amp = 100 mV	194		206	mV
IOUTLO sink current	$5\text{ V} \leq V_{IOUTLO} \leq 13\text{ V}$			250	nA
IOUT source current	$V_{IOUT} = 0.5\text{ V}$, $V_{IOUTLO} = 11.5\text{ V}$, $V_{HISENSE} = 12\text{ V}$	500			μA
IOUT sink current	$V_{IOUT} = 0.05\text{ V}$, $V_{IOUTLO} = 12\text{ V}$, $V_{HISENSE} = 12\text{ V}$	50			μA
Output voltage swing	$R_{IOUT} = 10\text{ k}\Omega$	$V_{HISENSE} = 11\text{ V}$	0	2	V
		$V_{HISENSE} = 4.5\text{ V}$	0	1.5	
		$V_{HISENSE} = 3\text{ V}$	0	0.75	
LOSENSE high-level input voltage	$V_{HISENSE} = 4.5\text{ V}$, See Note 2	2.85			V
LOSENSE low-level input voltage	$V_{HISENSE} = 4.5\text{ V}$, See Note 2			2.4	V
Sample/hold resistance	$11.4\text{ V} \leq V_{HISENSE} \leq 12.6\text{ V}$, LOSENSE connected to HISENSE, $V_{HISENSE} - V_{IOUTLO} = 0.15\text{ V}$	50	60	80	Ω
	$4.5\text{ V} \leq V_{HISENSE} \leq 5.5\text{ V}$, LOSENSE connected to HISENSE, $V_{HISENSE} - V_{IOUTLO} = 0.15\text{ V}$	62	85	123	
	$3\text{ V} \leq V_{HISENSE} \leq 3.6\text{ V}$, LOSENSE connected to HISENSE, $V_{HISENSE} - V_{IOUTLO} = 0.15\text{ V}$	67	95	144	
CMRR	$V_{HISENSE} = 12.6\text{ V}$ to 3 V , $V_{HISENSE} - V_{IOUTLO} = 100\text{ mV}$	69	75		dB

NOTE 2: Ensured by design, not tested.

deadtime

PARAMETER	TEST CONDITIONS	MIN	TYP	MAX	UNIT
LOHIB	High-level input voltage	See Note 2	2.4		V
LODR		See Note 2	3		
LOHIB	Low-level input voltage	See Note 2		1.4	V
LODR		See Note 2		1.7	

NOTE 2: Ensured by design, not tested.

LODRV

PARAMETER	TEST CONDITIONS	MIN	TYP	MAX	UNIT
LODRV	High-level input voltage	1.85			V
	Low-level input voltage			0.95	V

drive regulator

PARAMETER	TEST CONDITIONS	MIN	TYP	MAX	UNIT
Output voltage	$11.4\text{ V} \leq V_{CC} \leq 12.6\text{ V}$, $I_{DRV} = 50\text{ mA}$	7		9	V
Output regulation	$1\text{ mA} \leq I_{DRV} \leq 500\text{ mA}$		100		mV
Short-circuit current		100			mA



TPS5615, TPS5618, TPS5625, TPS5633 SYNCHRONOUS-BUCK HYSTERETIC REGULATOR CONTROLLER

SLVS177B – SEPTEMBER 1998 – REVISED JULY 2000

**electrical characteristics over recommended operating virtual junction temperature range,
 $V_{CC} = 12\text{ V}$, $I_{DRV} = 0\text{ A}$ (unless otherwise noted) (continued)**

bias regulator

PARAMETER	TEST CONDITIONS	MIN	TYP	MAX	UNIT
Output voltage	$11.4\text{ V} \leq V_{CC} \leq 12.6\text{ V}$, See Note 3	6			V

NOTE 3: The bias regulator is designed to provide a quiet bias supply for the TPS56xx controller. External loads should not be driven by the bias regulator.

output drivers

PARAMETER (see Note 4)	TEST CONDITIONS	MIN	TYP	MAX	UNIT	
Peak output current	High-side sink	Duty cycle < 2%, $t_{pw} < 100\ \mu\text{s}$, $T_J = 125^\circ\text{C}$, $V_{BOOT} - V_{BOOTLO} = 6.5\text{ V}$, $V_{HIGHDR} = 1.5\text{ V (SRC)}$ or 5 V (sink) , See Note 2	2		A	
	High-side source		2			
	Low-side sink		2			
	Low-side source		2			
Output resistance	High-side sink	$T_J = 125^\circ\text{C}$, $V_{BOOT} - V_{BOOTLO} = 6.5\text{ V}$, $V_{HIGHDR} = 1.5\text{ V (SRC)}$ or 5 V (sink)		3	Ω	
	High-side source			45		
	Low-side sink		$T_J = 125^\circ\text{C}$, $V_{DRV} = 6.5\text{ V}$,			5.7
	Low-side source		$V_{LOWDR} = 1.5\text{ V (SRC)}$ or 5 V (sink)			45

NOTES: 2. Ensured by design, not tested.

4. The pull up/down circuits of the drivers are bipolar and MOSFET transistors in parallel. The peak output current rating is the combined current from the bipolar and MOSFET transistors. The output resistance is the $R_{DS(ON)}$ of the MOSFET transistor when the voltage on the driver output is less than the saturation voltage of the bipolar transistor.

supply current

PARAMETER	TEST CONDITIONS	MIN	TYP	MAX	UNIT
V_{CC} supply voltage range		11.4	12	13	V
V_{CC} quiescent current	$V_{INHIBIT} = 5\text{ V}$, $V_{BOOTLO} = 0\text{ V}$, $V_{CC} > 10.75\text{ V}$ at startup, See Note 2		3	10	mA
	$V_{INHIBIT} = 5\text{ V}$, $V_{BOOTLO} = 0\text{ V}$, $C_{HIGHDR} = 50\text{ pF}$, $C_{LOWDR} = 50\text{ pF}$, $f_{swx} = 200\text{ kHz}$		5		
High-side drive regulator quiescent current	$V_{INHIBIT} = 0\text{ V}$ or $V_{CC} < 9.25\text{ V}$ at startup, $V_{BOOT} = 13\text{ V}$, $V_{BOOTLO} = 0\text{ V}$			80	μA
	$V_{INHIBIT} = 5\text{ V}$, $V_{BOOT} = 13\text{ V}$, $C_{HIGHDR} = 50\text{ pF}$, $V_{BOOTLO} = 0\text{ V}$, $f_{swx} = 200\text{ kHz}$		2		mA

NOTE 2: Ensured by design, not tested.



TPS5615, TPS5618, TPS5625, TPS5633 SYNCHRONOUS-BUCK HYSTERETIC REGULATOR CONTROLLER

SLVS177B – SEPTEMBER 1998 – REVISED JULY 2000

switching characteristics over recommended operating virtual junction temperature range,
 $V_{CC} = 12\text{ V}$, $I_{DRV} = 0\text{ V}$ (unless otherwise noted)

PARAMETER		TEST CONDITIONS	MIN	TYP	MAX	UNIT
Propagation delay	VSENSE to HIGHDR or LOWDR (excluding deadtime)	Overdrive = 10 mV (see Note 2)		150	250	ns
	OCP comparator	See Note 2		1		μs
	OVP comparator	See Note 2		1		
	PWRGD comparator	See Note 2		1		
	SLOWST comparator	Overdrive = 10 mV (see Note 2)		560	900	ns
Rise time	HIGHDR output	$C_L = 9\text{ nF}$, $V_{BOOT} = 6.5\text{ V}$, $V_{BOOTLO} = 0\text{ V}$, $T_J = 125^\circ\text{C}$			60	ns
	LOWDR output	$C_L = 9\text{ nF}$, $V_{DRV} = 6.5\text{ V}$, $T_J = 125^\circ\text{C}$			60	
Fall time	HIGHDR output	$C_L = 9\text{ nF}$, $V_{BOOT} = 6.5\text{ V}$, $V_{BOOTLO} = 0\text{ V}$, $T_J = 125^\circ\text{C}$			60	ns
	LOWDR output	$C_L = 9\text{ nF}$, $V_{DRV} = 6.5\text{ V}$, $T_J = 125^\circ\text{C}$			60	
Deglitch time (includes comparator propagation delay)	OCP	See Note 2	2		5	μs
	OVP	See Note 2	2		5	
Response time	High-side VDS sensing	$V_{HISENSE} = 12\text{ V}$, V_{IOUTLO} pulsed from 12 V to 11.9 V, 100 ns rise/fall times, See Note 2			2	μs
		$V_{HISENSE} = 4.5\text{ V}$, V_{IOUTLO} pulsed from 4.5 V to 4.4 V, 100 ns rise/fall times, See Note 2			3	
		$V_{HISENSE} = 3\text{ V}$, V_{IOUTLO} pulsed from 3 V to 2.9 V, 100 ns rise/fall times, See Note 2			3	
Short-circuit protection rising-edge delay	SCP	$LOSENSE = 0\text{ V}$, (see Note 2)	300		500	ns
Turn-on/turn-off delay	V_{DS} sensing sample/hold switch	$3\text{ V} \leq V_{HISENSE} \leq 11\text{ V}$, $V_{LOSENSE} = V_{HISENSE}$ (see Note 2)	30		100	ns
Crossover delay time	LOWDR to HIGHDRV, and LOHIB to LOWDR	See Note 2	30		100	ns
Prefilter pole frequency	Hysteretic comparator	See Note 2		5		MHz
Propagation delay	LODRV	See Note 2			400	ns

NOTE 2: Ensured by design, not tested.



TYPICAL CHARACTERISTICS

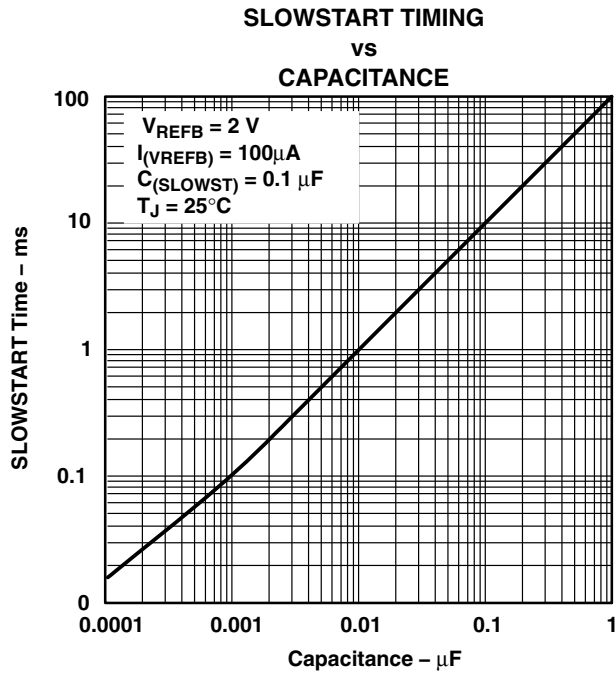

Figure 5

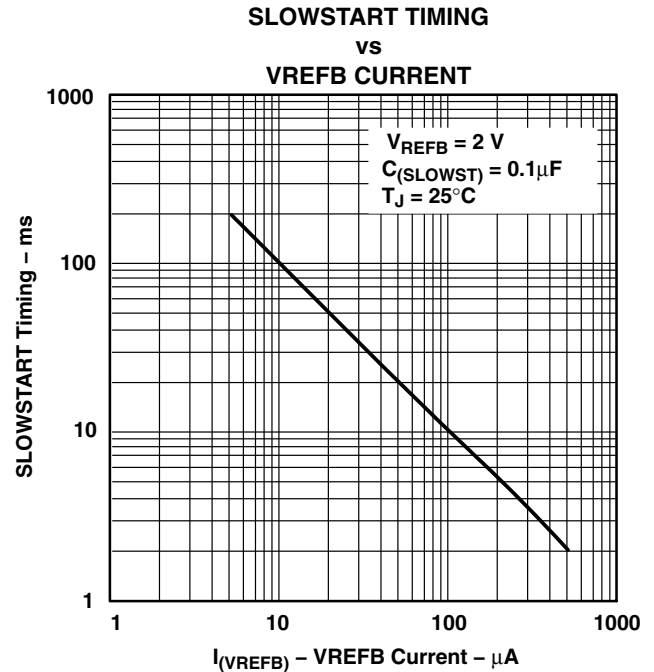

Figure 6

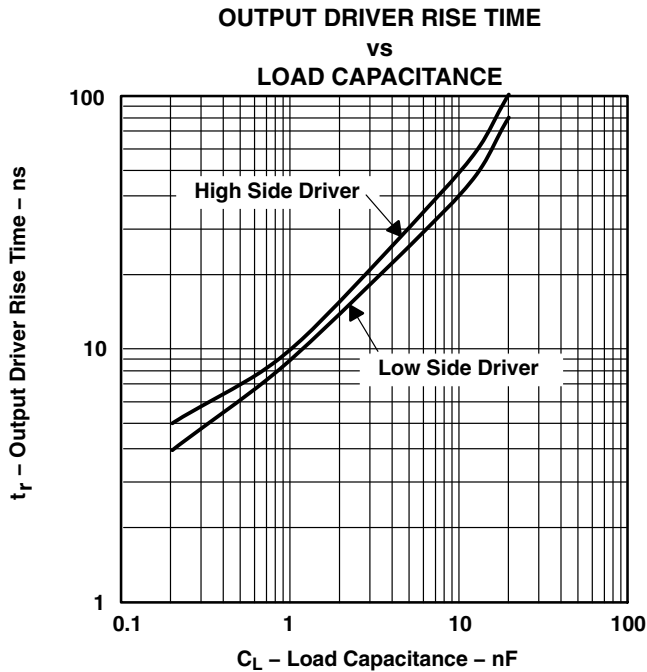

Figure 7

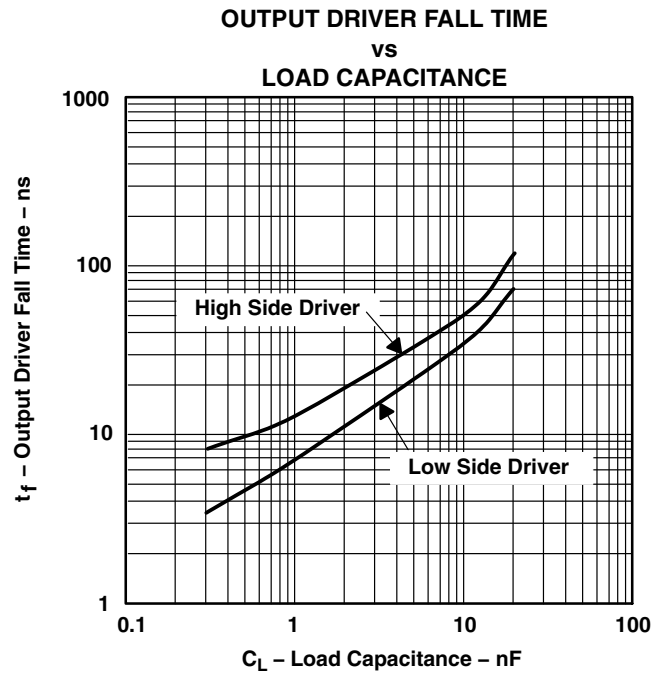

Figure 8

TPS5615, TPS5618, TPS5625, TPS5633 SYNCHRONOUS-BUCK HYSTERETIC REGULATOR CONTROLLER

SLVS177B – SEPTEMBER 1998 – REVISED JULY 2000

TYPICAL CHARACTERISTICS

**OVP THRESHOLD VOLTAGE
vs
JUNCTION TEMPERATURE**

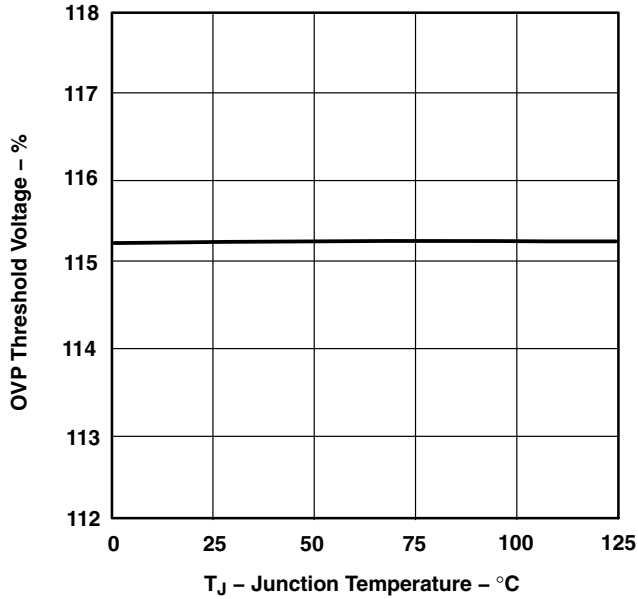

Figure 9

**OCP THRESHOLD VOLTAGE
vs
JUNCTION TEMPERATURE**

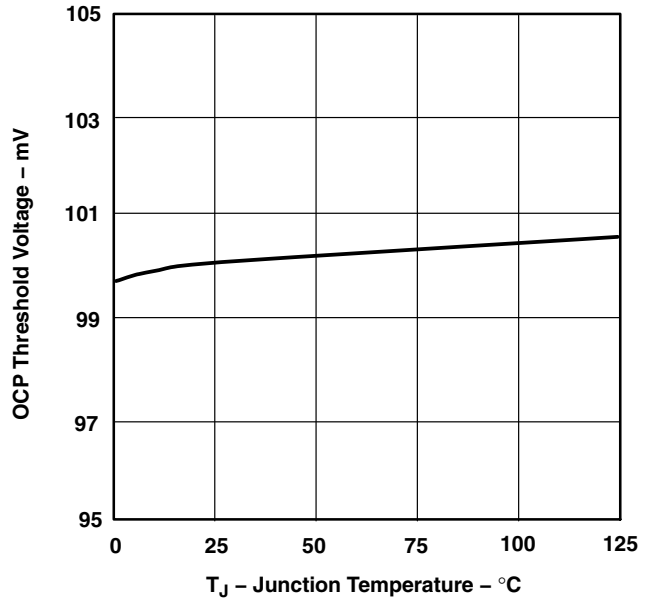

Figure 10

**INHIBIT START THRESHOLD VOLTAGE
vs
JUNCTION TEMPERATURE**

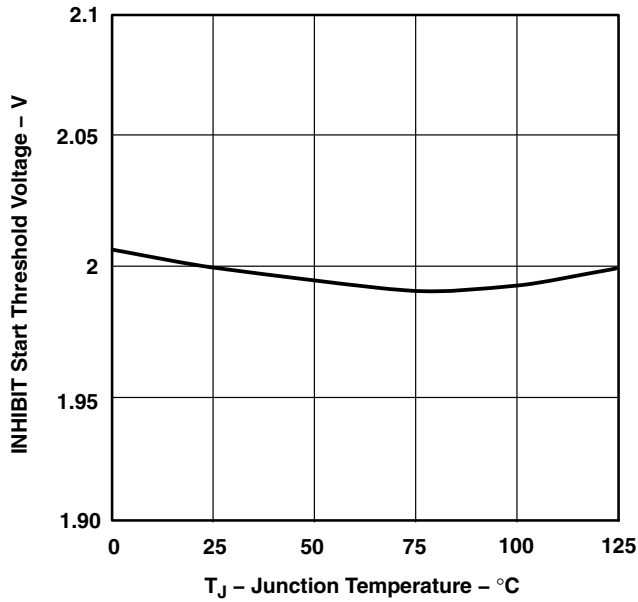

Figure 11

**INHIBIT HYSTERESIS VOLTAGE
vs
JUNCTION TEMPERATURE**

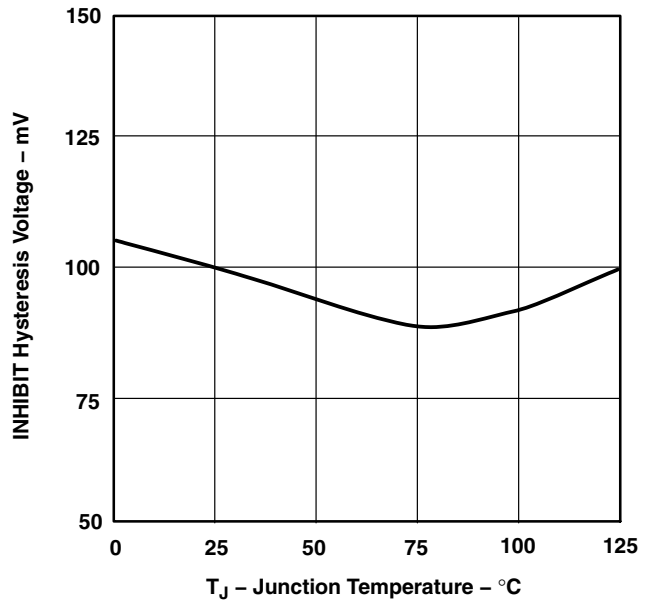
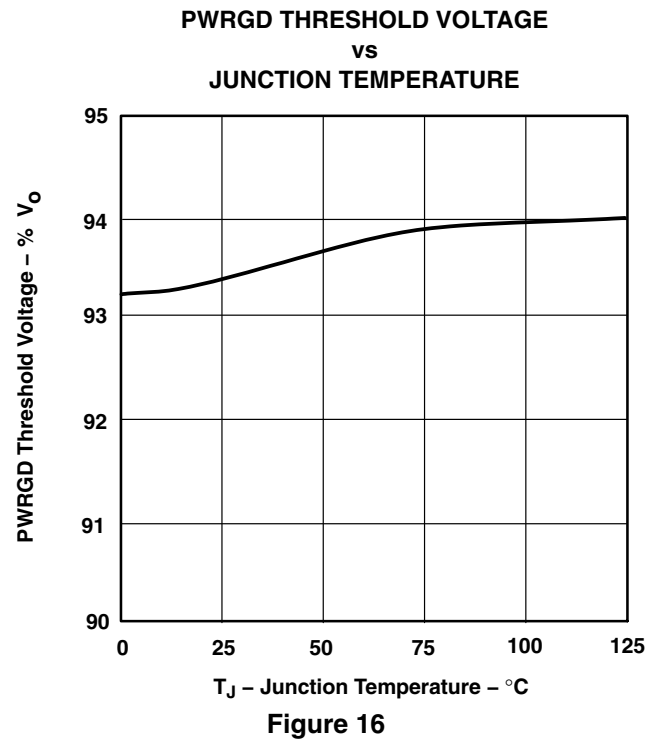
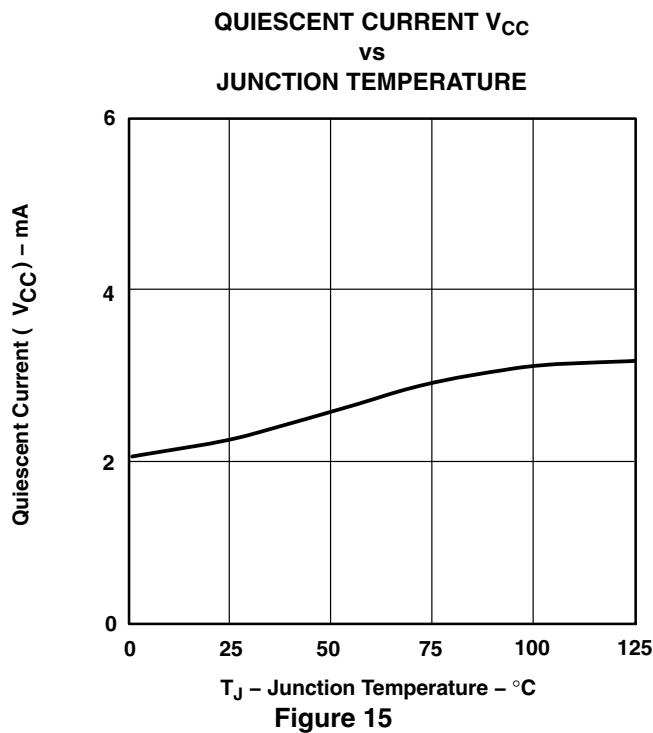
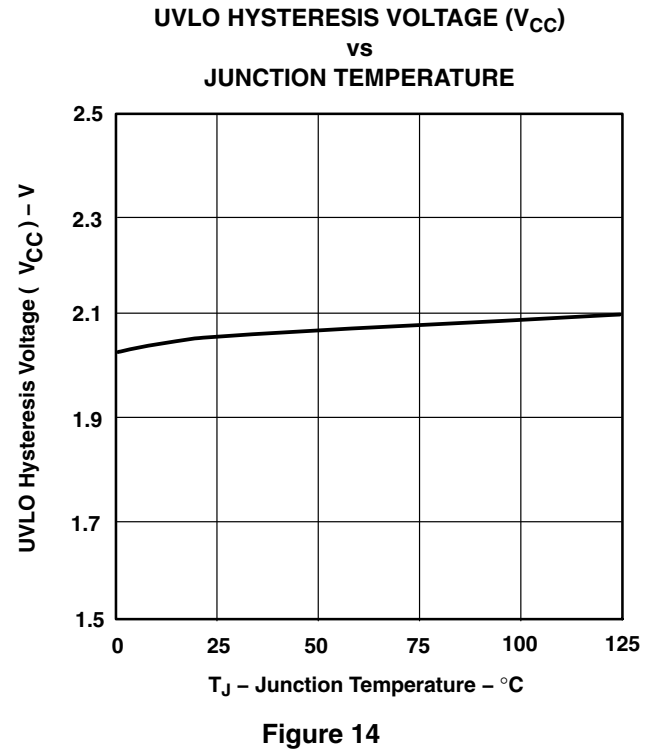
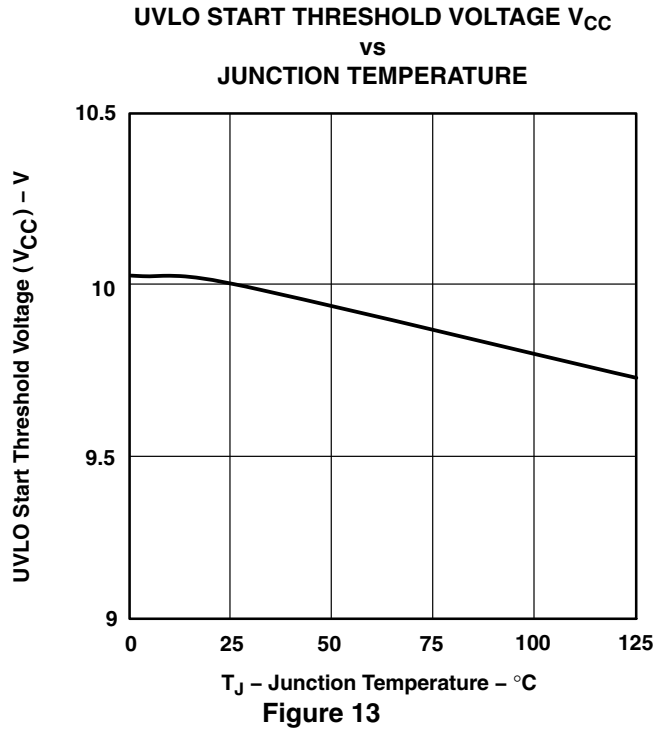

Figure 12



TYPICAL CHARACTERISTICS



TPS5615, TPS5618, TPS5625, TPS5633 SYNCHRONOUS-BUCK HYSTERETIC REGULATOR CONTROLLER

SLVS177B – SEPTEMBER 1998 – REVISED JULY 2000

TYPICAL CHARACTERISTICS

**SLOWSTART CHARGE CURRENT
vs
JUNCTION TEMPERATURE**

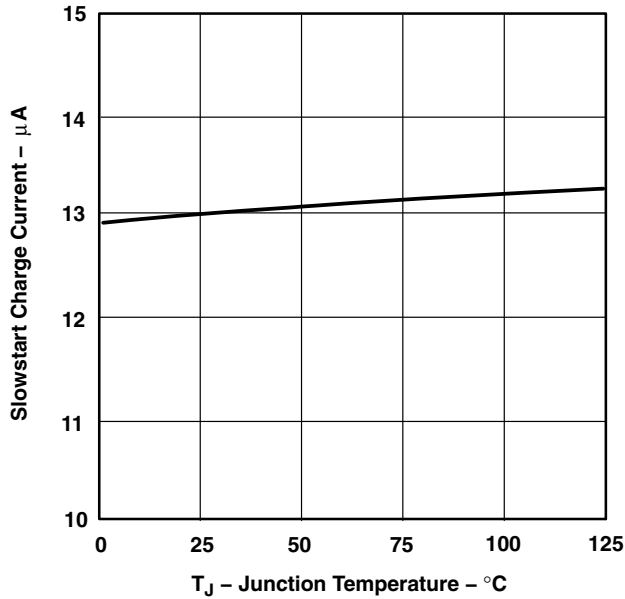

Figure 17

**VDS SAMPLE/HOLD RESISTANCE
vs
JUNCTION TEMPERATURE**

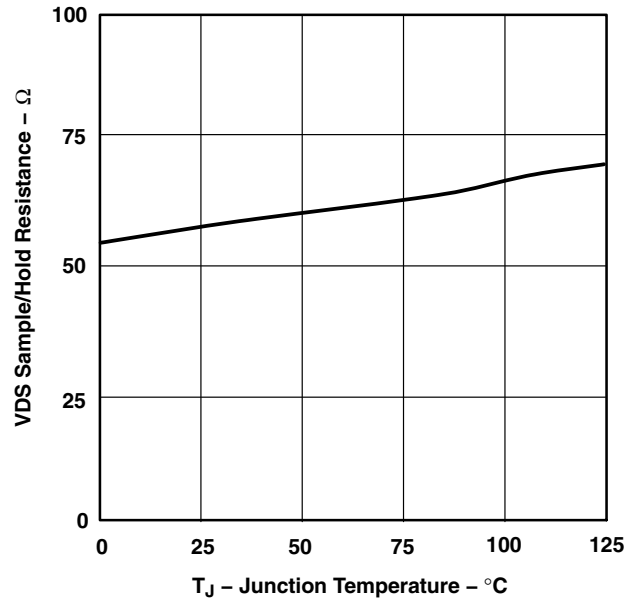

Figure 18

**DRIVE REGULATOR OUTPUT VOLTAGE
vs
JUNCTION TEMPERATURE**

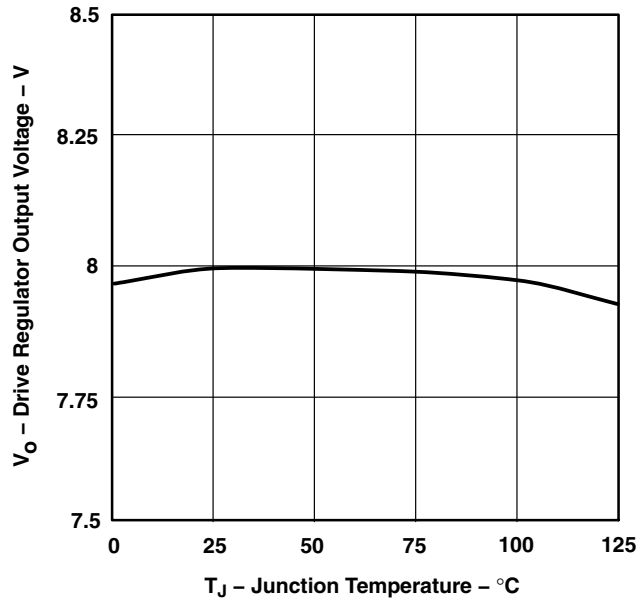

Figure 19

**DRIVE REGULATOR LOAD REGULATION
vs
JUNCTION TEMPERATURE**

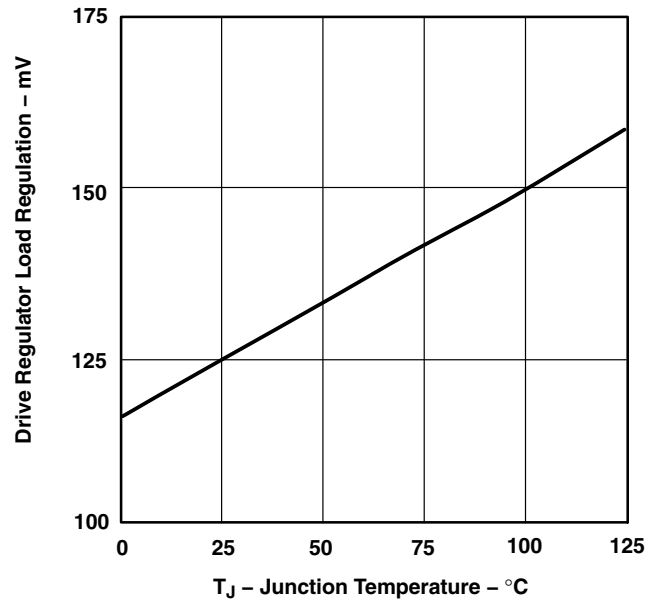

Figure 20



TYPICAL CHARACTERISTICS

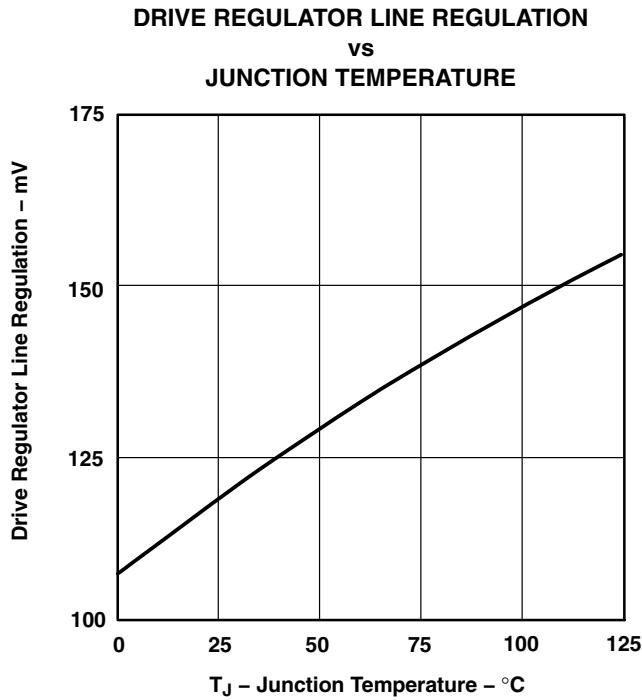

Figure 21

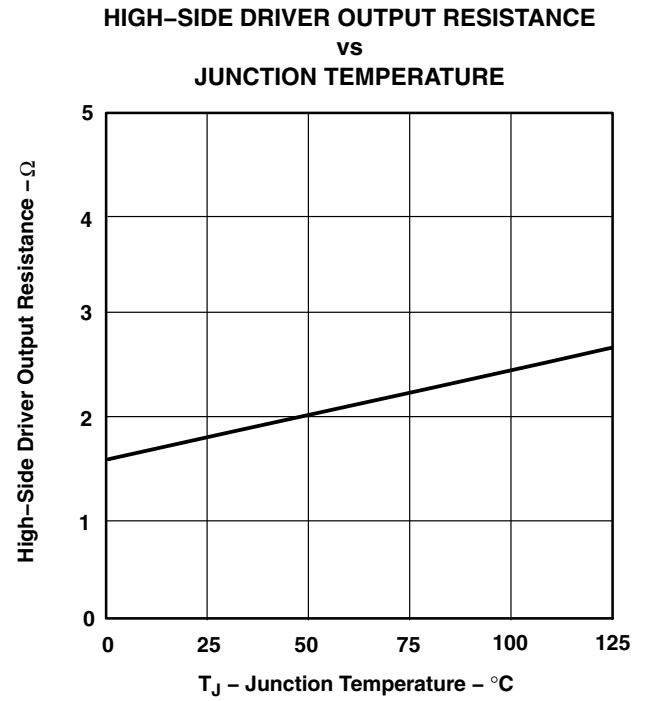

Figure 22

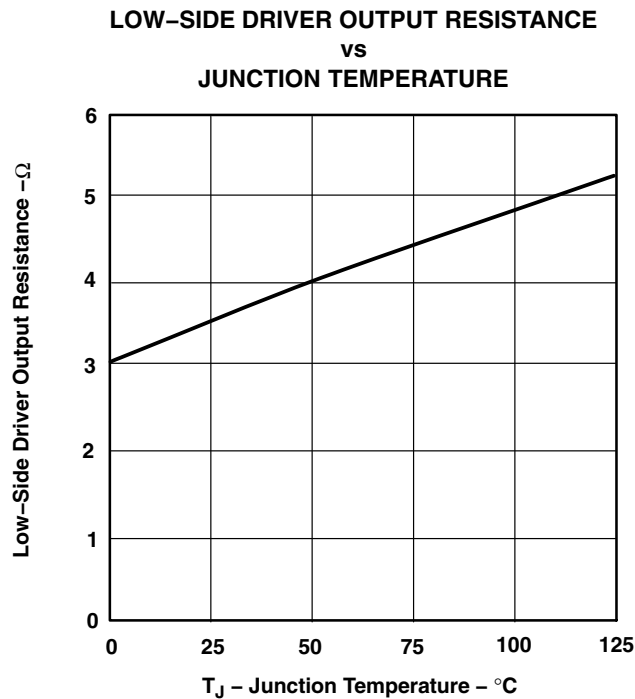

Figure 23

TPS5615, TPS5618, TPS5625, TPS5633 SYNCHRONOUS-BUCK HYSTERETIC REGULATOR CONTROLLER

SLVS177B – SEPTEMBER 1998 – REVISED JULY 2000

APPLICATION INFORMATION

Synchronous rectifier buck regulator circuits are used where high efficiency and low dropout voltages are required. The TPS56xx controller is useful in applications with very high transient loads and wide dc load ranges, such as multiple-DSP applications.

The circuit below will meet a wide variety of applications with maximum continuous-rated output currents of up to 8 A. Design tradeoffs, such as cost, size, or efficiency may need to be addressed for specific applications. Care should be taken in the proper layout (see last section of this data sheet for specific layout guidelines), especially in the higher-current configurations, to ensure that noise and ripple are kept to a minimum. Basic layout considerations are discussed in the *1996 Power Supply Circuits Databook* (Literature no. SLVD002). Design guidelines and equations are discussed in *Synchronous Buck Converter Design Using TPS56xx Controllers in SLVP10x EVMs User's Guide* (Literature no. SLVU007).



POST OFFICE BOX 655303 • DALLAS, TEXAS 75265

TPS5615, TPS5618, TPS5625, TPS5633 SYNCHRONOUS-BUCK HYSTERETIC REGULATOR CONTROLLER

SLVS177B – SEPTEMBER 1998 – REVISED JULY 2000

APPLICATION INFORMATION

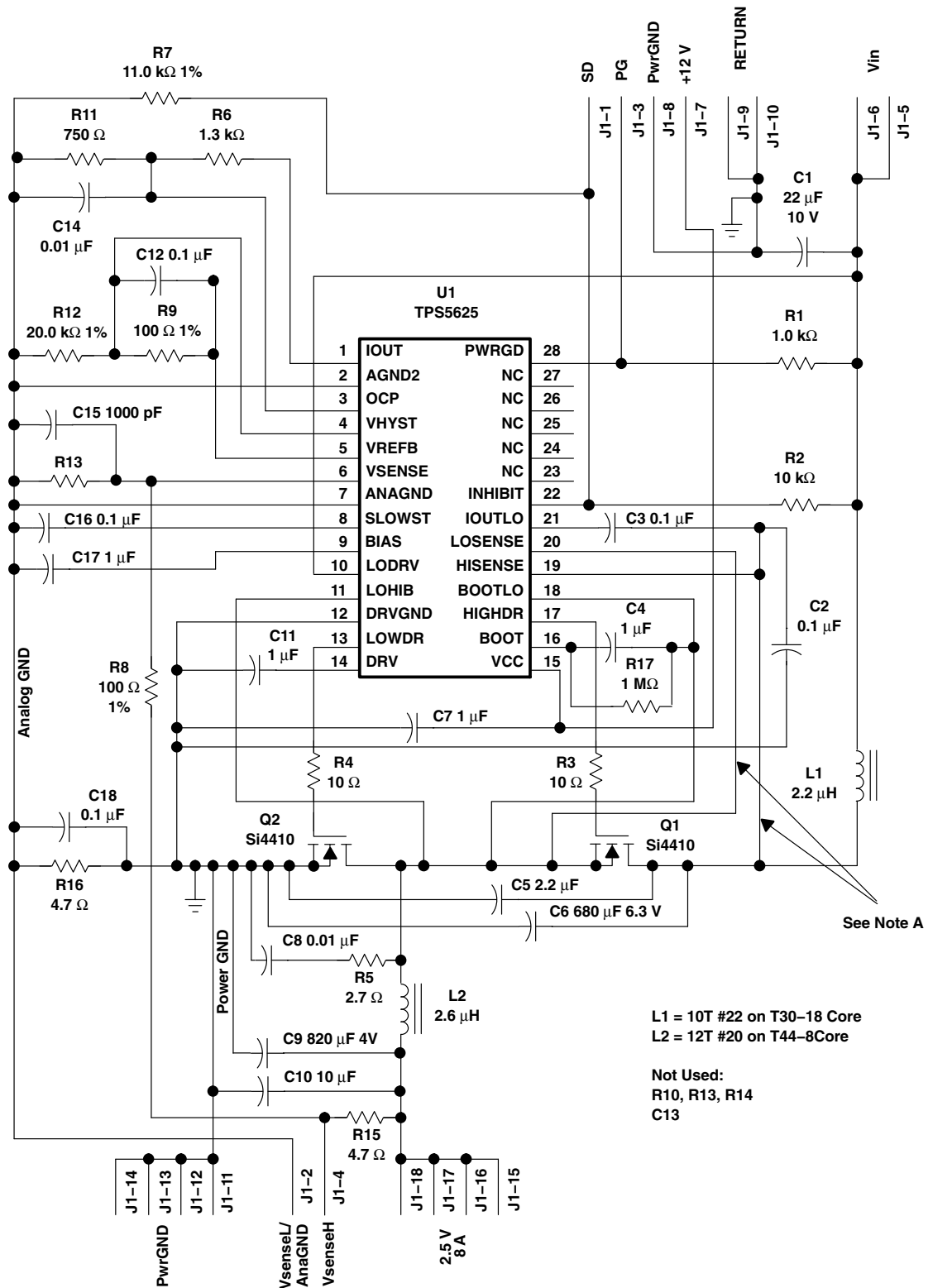

NOTE A: These two traces should be physically close to each other for good noise immunity.

Figure 24. Typical Design Schematic



TPS5615, TPS5618, TPS5625, TPS5633 SYNCHRONOUS-BUCK HYSTERETIC REGULATOR CONTROLLER

SLVS177B – SEPTEMBER 1998 – REVISED JULY 2000

Table 1. Test Results for 2.5-V, 8-A Converter

TEST	CONDITIONS	QTY	UNITS
Output voltage	$V_{IN} = 5.25\text{ V}$, $I_O = 8\text{ A}$	2.50	V
Load regulation	$V_{IN} = 5.25\text{ V}$, $I_O = 0.8\text{ to }8\text{ A}$	0.4	%
Line regulation	$I_O = 6\text{ A}$, $V_{CC} = 4.5\text{ V to }6\text{ V}$	0.2	%
Ripple	$V_{IN} = 5.25\text{ V}$, $I_O = 8\text{ A}$	50	mVpp
Efficiency	$V_{IN} = 5.25\text{ V}$, $I_O = 8\text{ A}$	89	%

Table 2. 2.5-V, 8-A Converter Bill of Materials

REF DES	QTY	PART NUMBER	DESCRIPTION	MFG
C1	1	10SS22M	Capacitor, Os-Con, 22 μF , 10 V, 20%	Sanyo
C2	4	GRM39X7R104K016A	Capacitor, Ceramic, 0.1 μF , 16 V, 10%, X7R	muRata
C3		GRM39X7R104K016A	Capacitor, Ceramic, 0.1 μF , 16 V, 10%, X7R	muRata
C4	4	GRM42-6Y5V105Z016A	Capacitor, Ceramic, 1 μF , 16 V, +80%–20%	muRata
C5	1	GRM42-6Y5V225Z016A	Capacitor, Os-Con, 2.2 μF , 16 V, Y5U	muRata
C6	1	6SP680M	Capacitor, Os-Con, 680 μF , 6.3 V, 20%	Sanyo
C7		GRM42-6Y5V105Z016A	Capacitor, Ceramic, 1 μF , 16 V, +80%–20%	muRata
C8	2	GRM39X7R103K025A	Capacitor, Ceramic, 0.01 μF , 25 V, 10%, X7R	muRata
C9	1	4SP820M	Capacitor, Os-Con, 820 μF , 4 V, 20%	Sanyo
C10	1	GRM235Y5V106Z016A	Capacitor, Ceramic, 10 μF , 16 V, Y5V	muRata
C11		GRM42-6Y5V105Z016A	Capacitor, Ceramic, 1 μF , 16 V, +80%–20%	muRata
C12		GRM39X7R104K016A	Capacitor, Ceramic, 0.1 μF , 16 V, 10%, X7R	muRata
C14		GRM39X7R103K025A	Capacitor, Ceramic, 0.01 μF , 25 V, 10%, X7R	muRata
C15	1	GRM39X7R102K050A	Capacitor, Ceramic, 1000 pF, 50 V, 10%, X7R	muRata
C16		GRM39X7R104K016A	Capacitor, Ceramic, 0.1 μF , 16 V, 10%, X7R	muRata
C17		GRM42-6Y5V105Z016A	Capacitor, Ceramic, 1 μF , 16 V, +80%–20%	muRata
C18		GRM39X7R104K016A	Capacitor, Ceramic, 0.1 μF , 16 V, 10%, X7R	muRata
J1	1	S1122-18-ND	Header, RA, 18-pin, 0.23 Posts \times 0.20 Tails	Sullins
L1	1		Inductor, Filter, 2.2 μH , 8.5 A (10T #22 on T30-18 Core)	
L2	1		Inductor, Filter, 2.6 μH , 8.5 A (12T #20 on T44-8 Core)	
Q1	2	Si4410DY	FET, N-ch, 30-V, 10-A, 13-m Ω	Siliconix
Q2		Si4410DY	FET, N-ch, 30-V, 10-A, 13-m Ω	Siliconix
R1	3	Std	Resistor, Chip, 1.0 k Ω , 1/16W, 5%	
R2	1	Std	Resistor, Chip, 10 k Ω , 1/16W, 5%	
R3	2	Std	Resistor, Chip, 10 Ω , 1/10W, 5%	
R4		Std	Resistor, Chip, 10 Ω , 1/10W, 5%	
R5	1	Std	Resistor, Chip, 2.7 Ω , 1/4W, 5%	
R6		Std	Resistor, Chip, 1.3 k Ω , 1/16W, 5%	
R7	1	Std	Resistor, Chip, 11.0 k Ω , 1/16W, 1%	
R8	2	Std	Resistor, Chip, 100 Ω , 1/16W, 1%	
R9		Std	Resistor, Chip, 100 Ω , 1/16W, 1%	
R11		Std	Resistor, Chip, 750 Ω , 1/16W, 5%	
R12	1	Std	Resistor, Chip, 20.0 k Ω , 1/16W, 1%	
R15	2	Std	Resistor, Chip, 4.7 Ω , 1/16W, 5%	
R16		Std	Resistor, Chip, 4.7 Ω , 1/16W, 5%	
R17	1	Std	Resistor, Chip, 1 M Ω , 1/16W, 5%	
U1	1	TPS5625PWP	IC, PWM Ripple Controller, Fixed 2.5 V	TI



APPLICATION INFORMATION

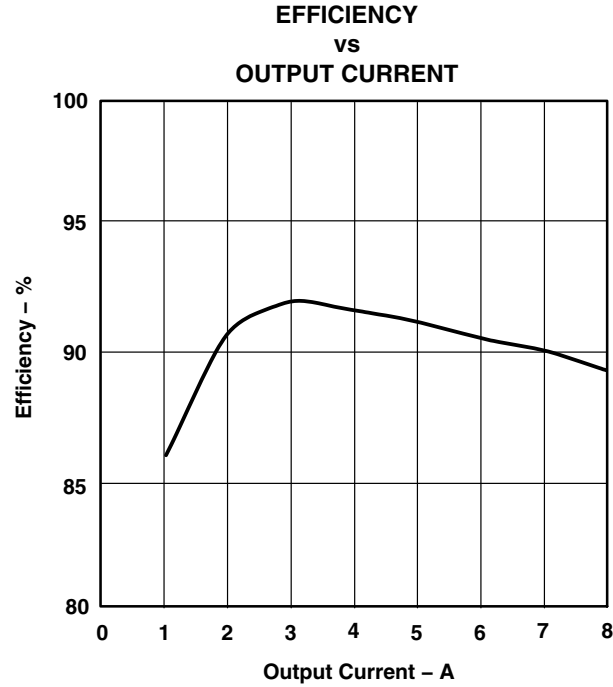

Figure 25

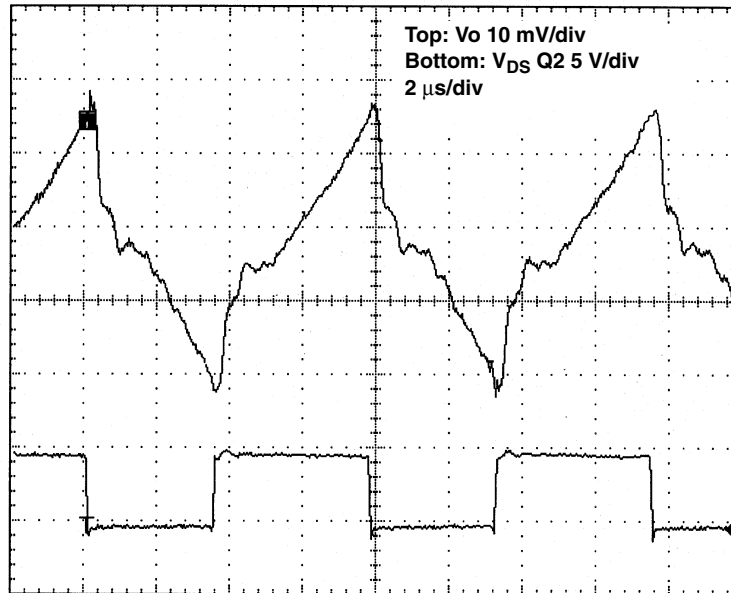

Figure 26. Output Voltage Ripple at 8 A

TPS5615, TPS5618, TPS5625, TPS5633 SYNCHRONOUS-BUCK HYSTERETIC REGULATOR CONTROLLER

SLVS177B – SEPTEMBER 1998 – REVISED JULY 2000

APPLICATION INFORMATION

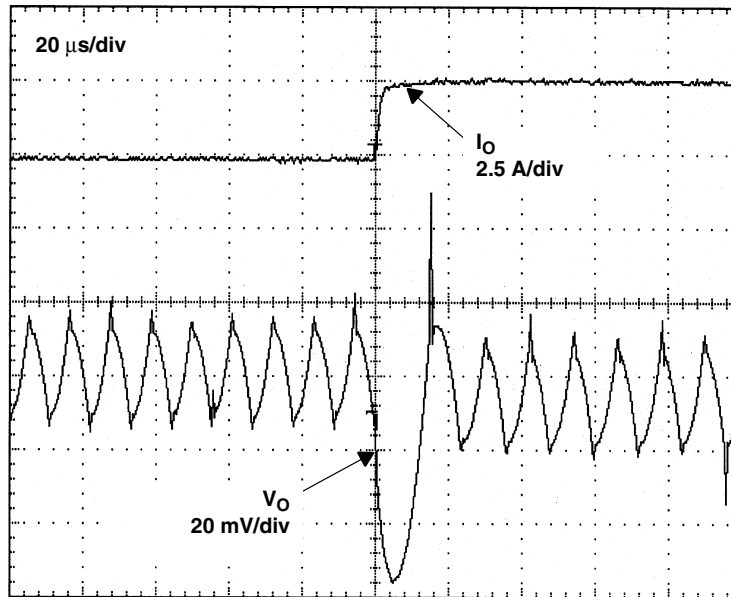

Figure 27. Rising Load Transient Response

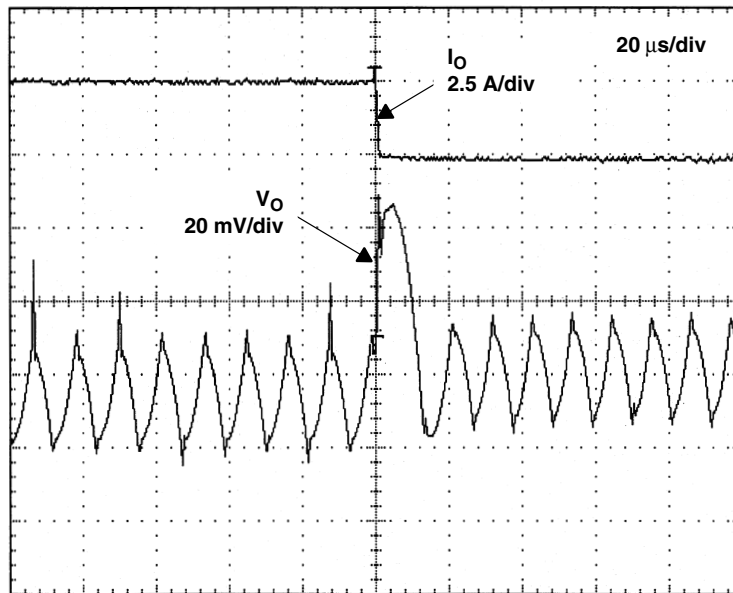

Figure 28. Falling Load Transient Response

APPLICATION INFORMATION

layout guidelines

Good power supply results will only occur when care is given to proper design and layout. Layout will affect noise pickup and generation and can cause a good design to perform with less than expected results. With a range of currents from milliamps to tens or even hundreds of amps, good power supply layout is much more difficult than most general PCB design. The general design should proceed from the switching node to the output, then back to the driver section and, finally, place the low-level components. Below are several specific points to consider before layout of a TPS56xx design begins.

1. All sensitive analog components should be referenced to ANAGND. These include components connected to SLOWST, IOUT, OCP, VSENSE, VREFB, VHYST, BIAS, and LOHIB.
2. Analog ground and drive ground should be isolated as much as possible. Ideally, analog ground will connect to the ground side of the bulk storage capacitors, on V_O , and drive ground will connect to the main ground plane close to the source of the low-side FET.
3. Connections from the drivers to the gate of the power FETs should be as short and wide as possible to reduce stray inductance. This becomes more critical if external gate resistors are not being used.
4. The bypass capacitor for the DRV regulator should be placed close to the TPS56xx and be connected to DRVGND.
5. The bypass capacitor for V_{CC} should be placed close to the TPS56xx and be connected to DRVGND.
6. When configuring the high-side driver as a floating driver, the connection from BOOTLO to the power FETs should be as short and as wide as possible. The other pins that also connect to the power FETs, LOHIB and LOSENSE, should have a separate connection to the FETs, since BOOTLO will have large peak currents flowing through it.
7. When configuring the high-side driver as a floating driver, the bootstrap capacitor (connected from BOOT to BOOTLO) should be placed close to the TPS56xx.
8. When configuring the high-side driver as a ground referenced driver, BOOTLO should be connected to DRVGND.
9. The bulk storage capacitors across V_I should be placed close to the power FETs. High-frequency bypass capacitors should be placed in parallel with the bulk capacitors and connected close to the drain of the high-side FET and close to the source of the low-side FET.
10. High-frequency bypass capacitors should be placed across the bulk storage capacitors on V_O .
11. HISENSE and LOSENSE should be connected very close to the drain and source, respectively, of the high-side FET. HISENSE and LOSENSE should be routed very close to each other to minimize differential-mode noise coupling to these traces.

PACKAGING INFORMATION

Orderable Device	Status (1)	Package Type	Package Drawing	Pins	Package Qty	Eco Plan (2)	Lead/Ball Finish (6)	MSL Peak Temp (3)	Op Temp (°C)	Device Marking (4/5)	Samples
TPS5618PWP	ACTIVE	HTSSOP	PWP	28	50	Green (RoHS & no Sb/Br)	CU NIPDAU	Level-2-260C-1 YEAR		TPS5618	Samples
TPS5633PWP	ACTIVE	HTSSOP	PWP	28	50	Green (RoHS & no Sb/Br)	CU NIPDAU	Level-2-260C-1 YEAR		TPS5633	Samples

(1) The marketing status values are defined as follows:

ACTIVE: Product device recommended for new designs.

LIFEBUY: TI has announced that the device will be discontinued, and a lifetime-buy period is in effect.

NRND: Not recommended for new designs. Device is in production to support existing customers, but TI does not recommend using this part in a new design.

PREVIEW: Device has been announced but is not in production. Samples may or may not be available.

OBSELETE: TI has discontinued the production of the device.

(2) Eco Plan - The planned eco-friendly classification: Pb-Free (RoHS), Pb-Free (RoHS Exempt), or Green (RoHS & no Sb/Br) - please check <http://www.ti.com/productcontent> for the latest availability information and additional product content details.

TBD: The Pb-Free/Green conversion plan has not been defined.

Pb-Free (RoHS): TI's terms "Lead-Free" or "Pb-Free" mean semiconductor products that are compatible with the current RoHS requirements for all 6 substances, including the requirement that lead not exceed 0.1% by weight in homogeneous materials. Where designed to be soldered at high temperatures, TI Pb-Free products are suitable for use in specified lead-free processes.

Pb-Free (RoHS Exempt): This component has a RoHS exemption for either 1) lead-based flip-chip solder bumps used between the die and package, or 2) lead-based die adhesive used between the die and leadframe. The component is otherwise considered Pb-Free (RoHS compatible) as defined above.

Green (RoHS & no Sb/Br): TI defines "Green" to mean Pb-Free (RoHS compatible), and free of Bromine (Br) and Antimony (Sb) based flame retardants (Br or Sb do not exceed 0.1% by weight in homogeneous material)

(3) MSL, Peak Temp. - The Moisture Sensitivity Level rating according to the JEDEC industry standard classifications, and peak solder temperature.

(4) There may be additional marking, which relates to the logo, the lot trace code information, or the environmental category on the device.

(5) Multiple Device Markings will be inside parentheses. Only one Device Marking contained in parentheses and separated by a "~" will appear on a device. If a line is indented then it is a continuation of the previous line and the two combined represent the entire Device Marking for that device.

(6) Lead/Ball Finish - Orderable Devices may have multiple material finish options. Finish options are separated by a vertical ruled line. Lead/Ball Finish values may wrap to two lines if the finish value exceeds the maximum column width.

Important Information and Disclaimer: The information provided on this page represents TI's knowledge and belief as of the date that it is provided. TI bases its knowledge and belief on information provided by third parties, and makes no representation or warranty as to the accuracy of such information. Efforts are underway to better integrate information from third parties. TI has taken and continues to take reasonable steps to provide representative and accurate information but may not have conducted destructive testing or chemical analysis on incoming materials and chemicals. TI and TI suppliers consider certain information to be proprietary, and thus CAS numbers and other limited information may not be available for release.

In no event shall TI's liability arising out of such information exceed the total purchase price of the TI part(s) at issue in this document sold by TI to Customer on an annual basis.

MECHANICAL DATA

PWP (R-PDSO-G28)

PowerPAD™ PLASTIC SMALL OUTLINE

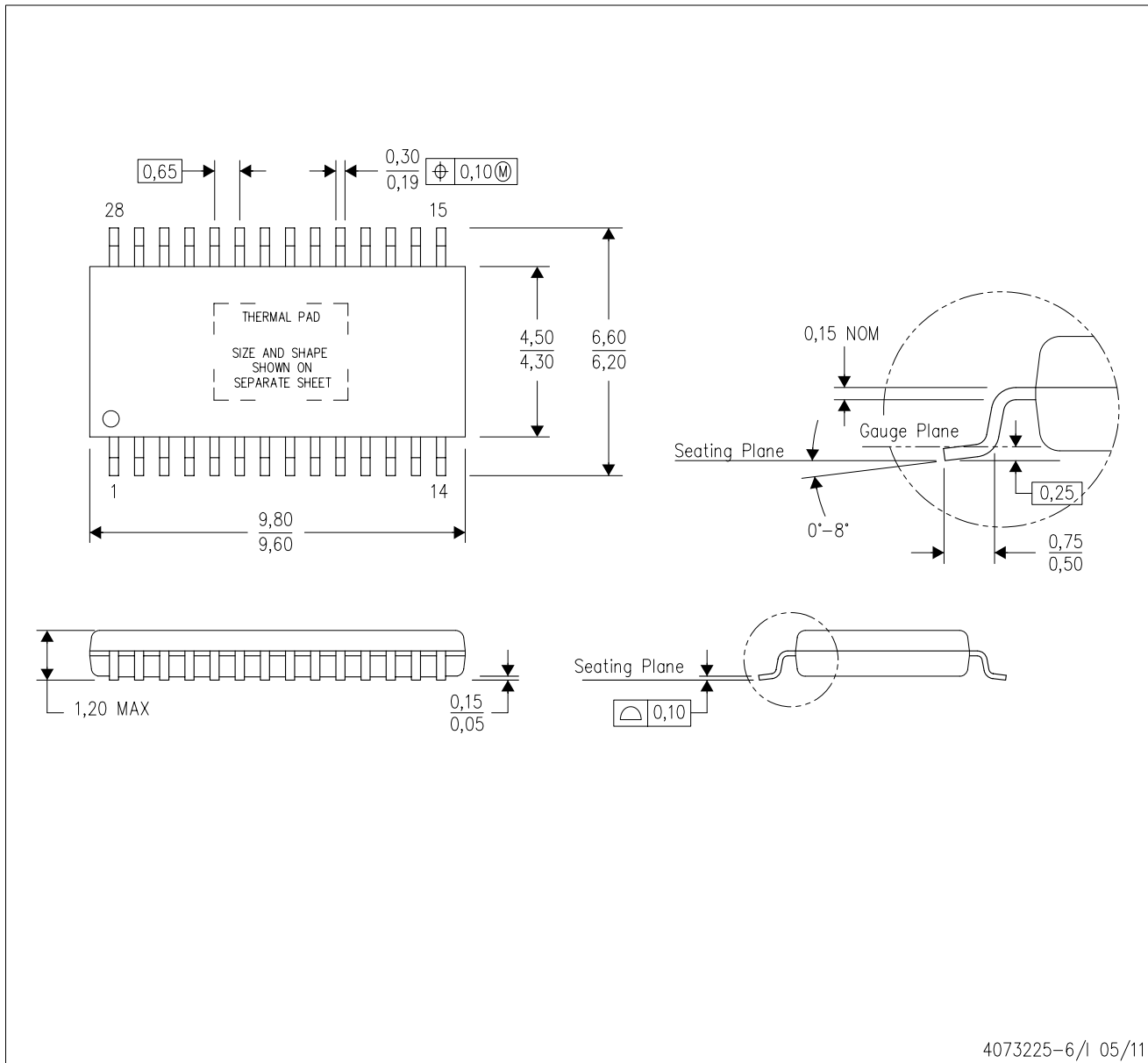

- NOTES:
- All linear dimensions are in millimeters.
 - This drawing is subject to change without notice.
 - Body dimensions do not include mold flash or protrusions. Mold flash and protrusion shall not exceed 0.15 per side.
 - This package is designed to be soldered to a thermal pad on the board. Refer to Technical Brief, PowerPad Thermally Enhanced Package, Texas Instruments Literature No. SLMA002 for information regarding recommended board layout. This document is available at www.ti.com <<http://www.ti.com>>.
 - See the additional figure in the Product Data Sheet for details regarding the exposed thermal pad features and dimensions.
 - Falls within JEDEC MO-153

PowerPAD is a trademark of Texas Instruments.

THERMAL PAD MECHANICAL DATA

PWP (R-PDSO-G28) PowerPAD™ SMALL PLASTIC OUTLINE

THERMAL INFORMATION

This PowerPAD™ package incorporates an exposed thermal pad that is designed to be attached to a printed circuit board (PCB). The thermal pad must be soldered directly to the PCB. After soldering, the PCB can be used as a heatsink. In addition, through the use of thermal vias, the thermal pad can be attached directly to the appropriate copper plane shown in the electrical schematic for the device, or alternatively, can be attached to a special heatsink structure designed into the PCB. This design optimizes the heat transfer from the integrated circuit (IC).

For additional information on the PowerPAD package and how to take advantage of its heat dissipating abilities, refer to Technical Brief, PowerPAD Thermally Enhanced Package, Texas Instruments Literature No. SLMA002 and Application Brief, PowerPAD Made Easy, Texas Instruments Literature No. SLMA004. Both documents are available at www.ti.com.

The exposed thermal pad dimensions for this package are shown in the following illustration.

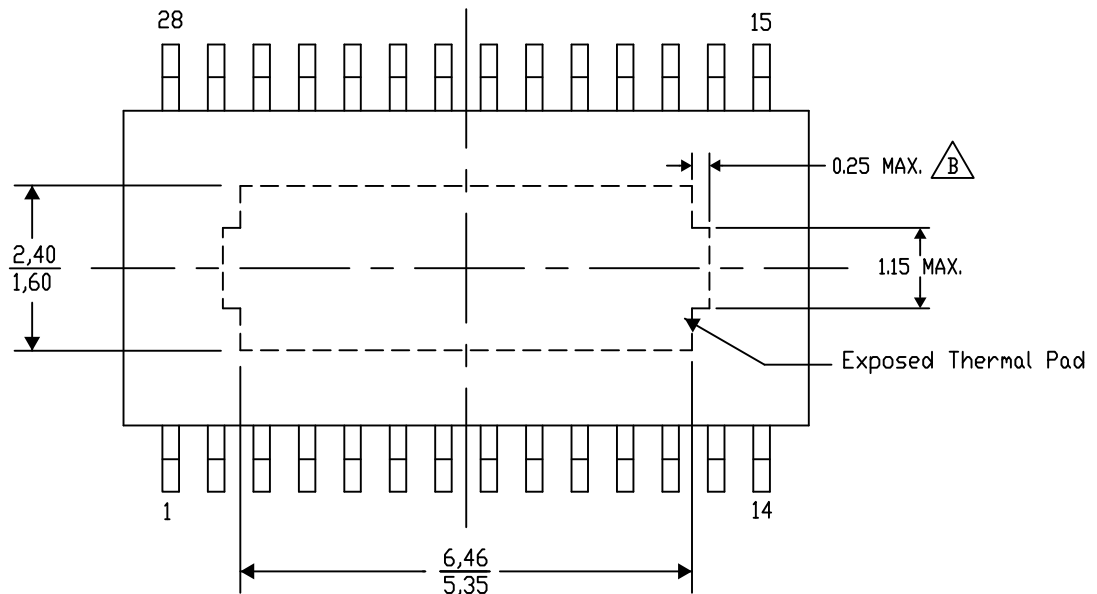

Top View

Exposed Thermal Pad Dimensions

4206332-34/AH 11/13

NOTE: A. All linear dimensions are in millimeters
 $\triangle B$. Exposed tie strap features may not be present.

PowerPAD is a trademark of Texas Instruments

PWP (R-PDSO-G28)

PowerPAD™ PLASTIC SMALL OUTLINE

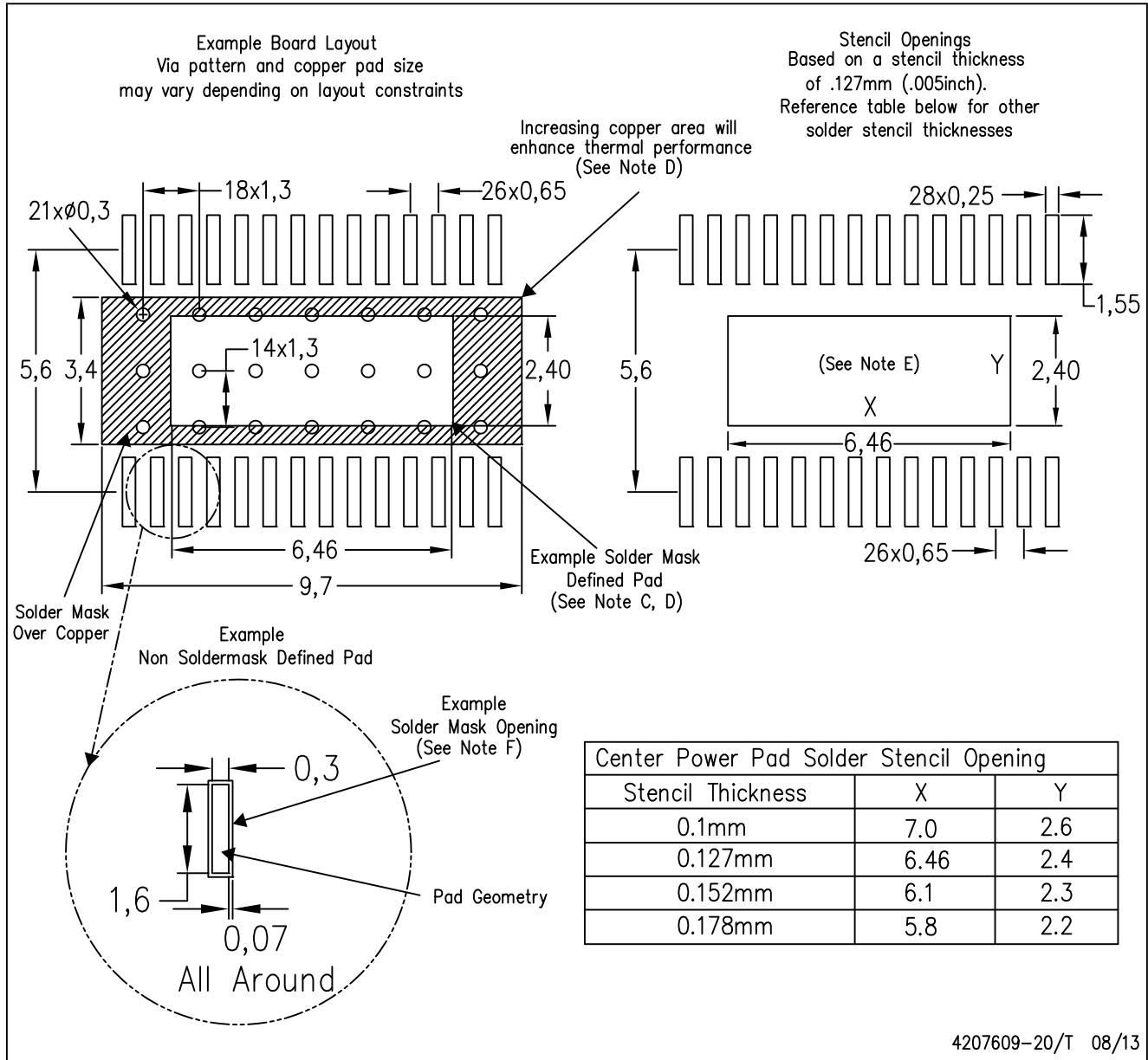

- NOTES:
- All linear dimensions are in millimeters.
 - This drawing is subject to change without notice.
 - Customers should place a note on the circuit board fabrication drawing not to alter the center solder mask defined pad.
 - This package is designed to be soldered to a thermal pad on the board. Refer to Technical Brief, PowerPAD Thermally Enhanced Package, Texas Instruments Literature No. SLMA002, SLMA004, and also the Product Data Sheets for specific thermal information, via requirements, and recommended board layout. These documents are available at www.ti.com <<http://www.ti.com>>. Publication IPC-7351 is recommended for alternate designs.
 - Laser cutting apertures with trapezoidal walls and also rounding corners will offer better paste release. Customers should contact their board assembly site for stencil design recommendations. Example stencil design based on a 50% volumetric metal load solder paste. Refer to IPC-7525 for other stencil recommendations.
 - Customers should contact their board fabrication site for solder mask tolerances between and around signal pads.

IMPORTANT NOTICE

Texas Instruments Incorporated and its subsidiaries (TI) reserve the right to make corrections, enhancements, improvements and other changes to its semiconductor products and services per JESD46, latest issue, and to discontinue any product or service per JESD48, latest issue. Buyers should obtain the latest relevant information before placing orders and should verify that such information is current and complete. All semiconductor products (also referred to herein as "components") are sold subject to TI's terms and conditions of sale supplied at the time of order acknowledgment.

TI warrants performance of its components to the specifications applicable at the time of sale, in accordance with the warranty in TI's terms and conditions of sale of semiconductor products. Testing and other quality control techniques are used to the extent TI deems necessary to support this warranty. Except where mandated by applicable law, testing of all parameters of each component is not necessarily performed.

TI assumes no liability for applications assistance or the design of Buyers' products. Buyers are responsible for their products and applications using TI components. To minimize the risks associated with Buyers' products and applications, Buyers should provide adequate design and operating safeguards.

TI does not warrant or represent that any license, either express or implied, is granted under any patent right, copyright, mask work right, or other intellectual property right relating to any combination, machine, or process in which TI components or services are used. Information published by TI regarding third-party products or services does not constitute a license to use such products or services or a warranty or endorsement thereof. Use of such information may require a license from a third party under the patents or other intellectual property of the third party, or a license from TI under the patents or other intellectual property of TI.

Reproduction of significant portions of TI information in TI data books or data sheets is permissible only if reproduction is without alteration and is accompanied by all associated warranties, conditions, limitations, and notices. TI is not responsible or liable for such altered documentation. Information of third parties may be subject to additional restrictions.

Resale of TI components or services with statements different from or beyond the parameters stated by TI for that component or service voids all express and any implied warranties for the associated TI component or service and is an unfair and deceptive business practice. TI is not responsible or liable for any such statements.

Buyer acknowledges and agrees that it is solely responsible for compliance with all legal, regulatory and safety-related requirements concerning its products, and any use of TI components in its applications, notwithstanding any applications-related information or support that may be provided by TI. Buyer represents and agrees that it has all the necessary expertise to create and implement safeguards which anticipate dangerous consequences of failures, monitor failures and their consequences, lessen the likelihood of failures that might cause harm and take appropriate remedial actions. Buyer will fully indemnify TI and its representatives against any damages arising out of the use of any TI components in safety-critical applications.

In some cases, TI components may be promoted specifically to facilitate safety-related applications. With such components, TI's goal is to help enable customers to design and create their own end-product solutions that meet applicable functional safety standards and requirements. Nonetheless, such components are subject to these terms.

No TI components are authorized for use in FDA Class III (or similar life-critical medical equipment) unless authorized officers of the parties have executed a special agreement specifically governing such use.

Only those TI components which TI has specifically designated as military grade or "enhanced plastic" are designed and intended for use in military/aerospace applications or environments. Buyer acknowledges and agrees that any military or aerospace use of TI components which have **not** been so designated is solely at the Buyer's risk, and that Buyer is solely responsible for compliance with all legal and regulatory requirements in connection with such use.

TI has specifically designated certain components as meeting ISO/TS16949 requirements, mainly for automotive use. In any case of use of non-designated products, TI will not be responsible for any failure to meet ISO/TS16949.

Products

Audio	www.ti.com/audio
Amplifiers	amplifier.ti.com
Data Converters	dataconverter.ti.com
DLP® Products	www.dlp.com
DSP	dsp.ti.com
Clocks and Timers	www.ti.com/clocks
Interface	interface.ti.com
Logic	logic.ti.com
Power Mgmt	power.ti.com
Microcontrollers	microcontroller.ti.com
RFID	www.ti-rfid.com
OMAP Applications Processors	www.ti.com/omap
Wireless Connectivity	www.ti.com/wirelessconnectivity

Applications

Automotive and Transportation	www.ti.com/automotive
Communications and Telecom	www.ti.com/communications
Computers and Peripherals	www.ti.com/computers
Consumer Electronics	www.ti.com/consumer-apps
Energy and Lighting	www.ti.com/energy
Industrial	www.ti.com/industrial
Medical	www.ti.com/medical
Security	www.ti.com/security
Space, Avionics and Defense	www.ti.com/space-avionics-defense
Video and Imaging	www.ti.com/video

TI E2E Community

e2e.ti.com