

## SYNCHRONOUS BOOST CONVERTER WITH DOWN MODE HIGH POWER WHITE LED DRIVER

### FEATURES

- **80% Efficient Synchronous Boost Converter**
  - 500-mA LED Current From 3.3-V Input (TPS61058)
  - 800-mA LED Current From 3.3-V Input (TPS61059)
- **Input Voltage Range: 2.7 V to 5.5 V**
- **Fixed Frequency 650 kHz (Typ) Operation**
- **LED Disconnect During Shutdown**
- **Open/Shorted LED Protection**
- **Over-Temperature Protection**
- **Low Shutdown Current: 100 nA (Typ)**
- **Total Solution Of Less Than 80 mm<sup>2</sup>**
- **Small 3mm x 3mm QFN-10 Package**

### APPLICATIONS

- **Torch/Camera White LED Supply for Cell Phones, Smart-Phones and PDAs**

### DESCRIPTION

The TPS61058/9 devices are fixed frequency, synchronous boost dc-dc converters with an integrated down conversion mode. The devices are optimized for driving high power single cell white LEDs up to 800 mA from a 2.7-V to 5.5-V input. The LED current can be programmed to different levels (e.g. torch, flashlight) by a set of external resistors.

The boost converter is based on a 650 kHz fixed frequency, pulse-width-modulation (PWM) controller using a synchronous rectifier to obtain maximum efficiency. The maximum peak current in the boost switch is limited to 1000 mA (TPS61058) and 1500 mA (TPS61059).

The converter can be disabled to maximize battery life. In the shutdown mode, the load is completely disconnected and the current consumption is reduced to less than 1  $\mu$ A. Built-in precharge and soft-start circuitry prevents excessive inrush current during start-up.

The device is packaged in a 10-pin QFN PowerPAD™ package measuring 3 mm x 3 mm (DRC).

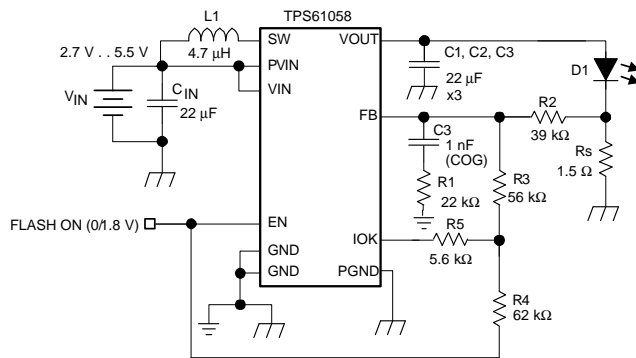

Figure 1. 500 mA Flashlight Application

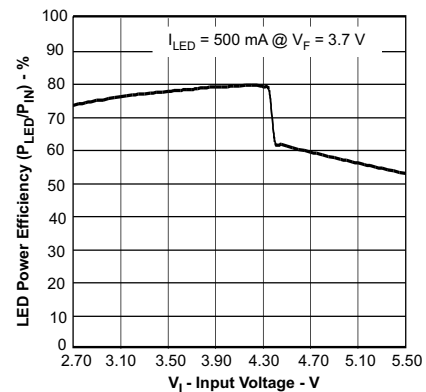

Figure 2. Flashlight Efficiency vs  $V_{IN}$

**TPS61058**  
**TPS61059**

SLVS572B–APRIL 2005–REVISED DECEMBER 2005

These devices have limited built-in ESD protection. The leads should be shorted together or the device placed in conductive foam during storage or handling to prevent electrostatic damage to the MOS gates.

**AVAILABLE OPTIONS**

$T_A$	CURRENT LIMIT	PACKAGE MARKING	PACKAGE	PART NUMBER <sup>(1)(2)</sup>
-40°C to 85°C	1000 mA	BNF	10-Pin QFN	TPS61058DRC
	1500 mA	BNG		TPS61059DRC

- (1) The DRC package is available taped and reeled. Add R suffix to device type (e.g. TPS61058DRCR, TPS61059DRCR) to order quantities of 3000 devices per reel.
- (2) For the most current package and ordering information, see the Package Option Addendum at the end of this document, or see the TI website at [www.ti.com](http://www.ti.com).

**ABSOLUTE MAXIMUM RATINGS**

over operating free-air temperature range (unless otherwise noted)<sup>(1)</sup>

	<b>TPS61058/9</b>
Input voltage range on PVIN, VIN, EN, FB, IOK, SW, VOUT	-0.3 V to 7 V
Power dissipation	Internally limited
Operation temperature range, $T_A$	-40°C to 85°C
Maximum operating junction temperature, $T_J(\text{max})$	150°C
Storage temperature range, $T_{\text{stg}}$	-65°C to 150°C

- (1) Stresses beyond those listed under "absolute maximum ratings" may cause permanent damage to the device. These are stress ratings only, and functional operation of the device at these or any other conditions beyond those indicated under "recommended operating conditions" is not implied. Exposure to absolute-maximum-rated conditions for extended periods may affect device reliability.

**DISSIPATION RATINGS TABLE**

PACKAGE	THERMAL RESISTANCE $\Theta_{JA}$	POWER RATING $T_A \leq 25^\circ\text{C}$	DERATING FACTOR ABOVE $T_A = 25^\circ\text{C}$
DRC	48.7 °C/W	2040 mW	21 mW/°C

**ELECTRICAL CHARACTERISTICS**

$V_{IN} = 3.6\text{ V}$ ,  $I_{LED} = 500\text{ mA}$ ,  $EN = V_{IN}$ ,  $L = 4.7\text{ }\mu\text{H}$ ,  $C_O = 3 \times 22\text{ }\mu\text{F}$ ,  $T_A = -40^\circ\text{C}$  to  $85^\circ\text{C}$ , typical values are at  $T_A = 25^\circ\text{C}$  (unless otherwise noted)

<b>DC/DC STAGE</b>						
<b>PARAMETER</b>		<b>TEST CONDITIONS</b>	<b>MIN</b>	<b>TYP</b>	<b>MAX</b>	<b>UNIT</b>
$V_{IN}$	Input voltage range	$V_O > 2.0\text{ V}$ @ $I_{LED} = 50\text{ mA}$	2.7		5.5	V
$V_{OUT}$	TPS61058/9 output voltage range		2.5		5.5	V
$V_{OVP}$	Output overvoltage protection		5.9	6.1	6.3	V
$V_{FB}$	TPS61058/9 feedback voltage		490	500	510	mV
f	Oscillator frequency		550	650	750	kHz
$I_{SW}$	Switch current limit (TPS61058)	$V_O = 3.3\text{ V}$	900	1100	1300	mA
	Switch current limit (TPS61059)	$V_O = 3.3\text{ V}$	1200	1500	1800	mA
	Pre-charge current	$V_O = 2.5\text{ V}$ , $T_A = -10^\circ\text{C}$ to $85^\circ\text{C}$	84			mA
$r_{DS(on)}$	SWN switch on resistance	$V_O = 3.3\text{ V}$		260		m $\Omega$
	SWP switch on resistance	$V_O = 3.3\text{ V}$		290		m $\Omega$
	Total accuracy (including line and load regulation)		-3%		3%	
$I_Q$	Quiescent current	$I_{LED} = 0\text{ mA}$ , $V_O = 5.0\text{ V}$ , Device switching at 650 kHz		5.5		mA
$I_{(SD)}$	Shutdown current	$EN = \text{GND}$ , $T_A = 25^\circ\text{C}$		0.1	1	$\mu\text{A}$
<b>CONTROL STAGE</b>						
	IOK switch on-resistance	$V_O = 5.0\text{ V}$ , $I_{IOK} = 100\text{ }\mu\text{A}$	0.6	0.8	1	k $\Omega$
	IOK output low current			100	300	$\mu\text{A}$
	IOK output leakage current	$V_{IOK} = 7\text{ V}$		0.01	0.1	$\mu\text{A}$
$V_{(IL)}$	EN low-level input voltage				0.4	V
$V_{(IH)}$	EN high-level input voltage		1.4			V
$I_{(I)}$	EN input leakage current	Input tied to GND		0.01	0.1	$\mu\text{A}$
	EN pull-down resistance			400		k $\Omega$
	Overtemperature protection			140		$^\circ\text{C}$
	Overtemperature hysteresis			20		$^\circ\text{C}$

**TPS61058**  
**TPS61059**

SLVS572B–APRIL 2005–REVISED DECEMBER 2005

**PIN ASSIGNMENTS**

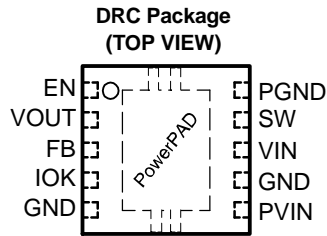

**Terminal Functions**

TERMINAL NAME	NO.	I/O	DESCRIPTION
EN	1	I	This is the enable pin of the device. Connect this pin to ground forces the device into shutdown mode. Pulling this pin above 1.4V enables the device. This pin has an internal pull-down resistor.
VOUT	2	O	This is the output of the dc-dc converter.
FB	3	I	This is the feedback pin of the device. The feedback pin measures the LED current through the sense resistor. The feedback voltage is set internally to 500mV.
IOK	4	O	This pin indicates that the dc-dc converter is ready for high current operation (open drain output).
GND	5, 7		Control / logic ground.
PVIN	6	I	This is the input voltage pin of the device. Connect directly to the input bypass capacitor.
VIN	8	I	This pin needs to be tied to the input voltage pin of the device.
SW	9	I	This is the switching pin of the converter.
PGND	10		Power ground.
PowerPAD™			Must be soldered to achieve appropriate power dissipation. Should be connected to PGND.

FUNCTIONAL BLOCK DIAGRAM (TPS61058/9)

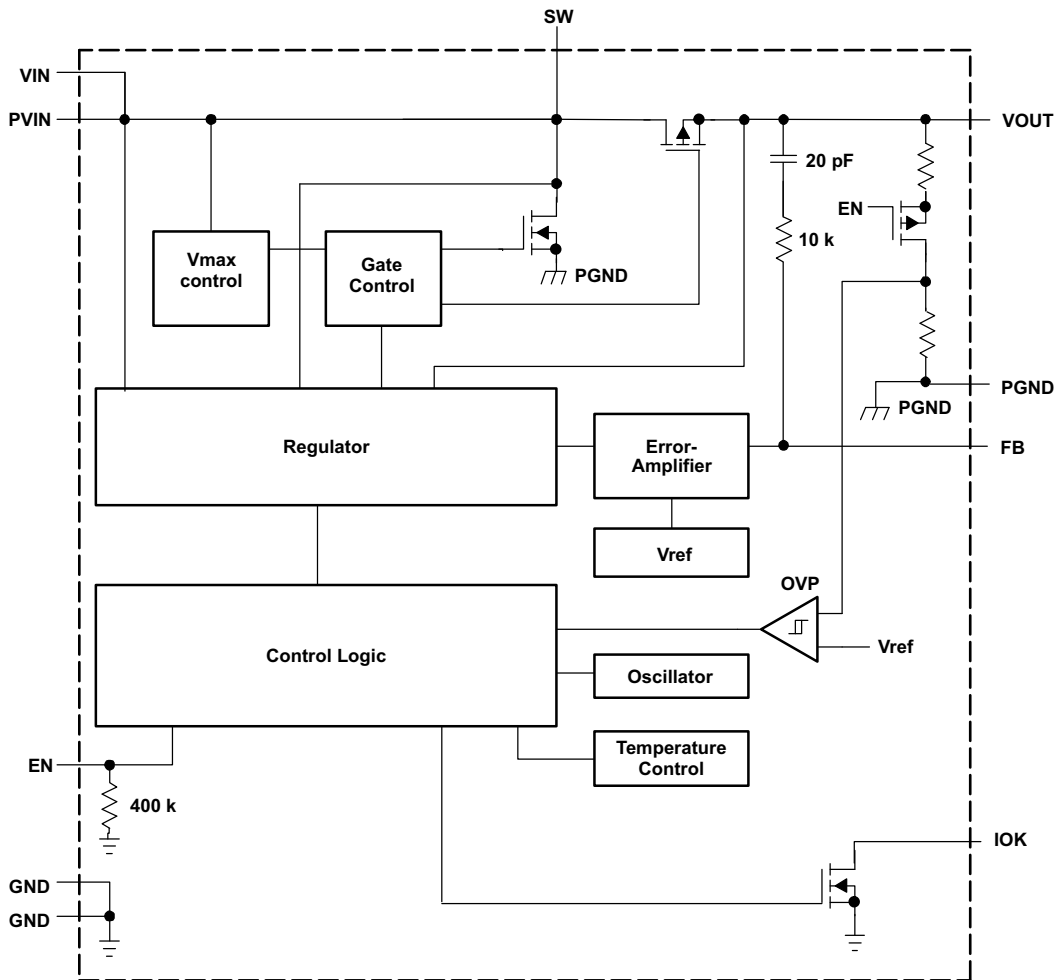

TPS61058  
TPS61059

SLVS572B – APRIL 2005 – REVISED DECEMBER 2005

PARAMETER MEASUREMENT INFORMATION

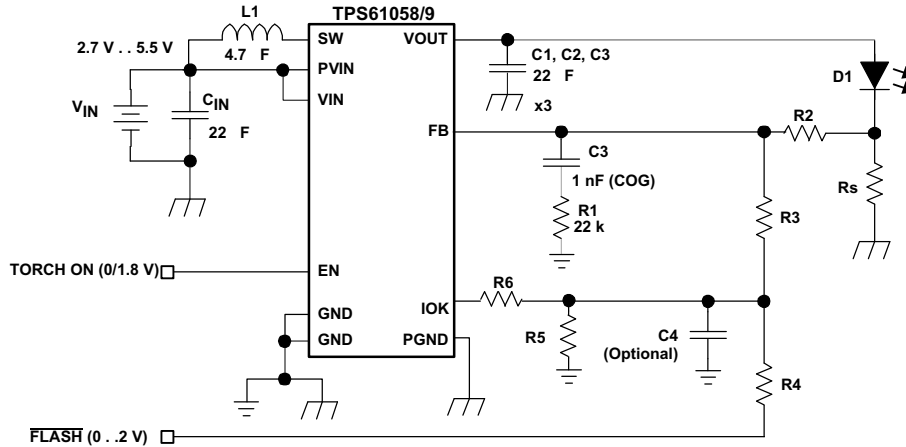

List of Components:

L1 = TDK VLF5014AT-4R7  
C1,C2,C3 = TDK C2012X5R0J226MTJ

500 mA Flashlight Application

Rs = 1.3  
R2 = 56 k  
R3 = 100 k  
R4 = 2.4 k  
R5 = 6.2 k  
R6 = 91 k

700 mA Flashlight Application

Rs = 1.2  
R2 = 47 k  
R3 = 51 k  
R4 = 3.3 k  
R5 = 4.3 k  
R6 = 120 k  
C4 = 100 nF

TYPICAL CHARACTERISTICS

Table of Graphs

		FIGURE
(TPS61058) LED Power Efficiency	vs. Input Voltage	3
(TPS61059) LED Power Efficiency	vs. Input Voltage	4
(TPS61058) LED Power Efficiency	vs LED Current	5
(TPS61058) DC Input Current	vs. Input Voltage	6
(TPS61058) LED Current	vs. Input Voltage	7
Oscillator Frequency		8
(TPS61059) Current Limit	vs. Temperature	9
Waveforms	Switching Waveforms in Boost Mode (TPS61058)	10
	Switching Waveforms in Down-Mode (TPS61058)	11
	High Current Flashlight Pulse Waveform (TPS61058)	12
	Torch to Flashlight Transistion (TPS61058)	13
	Start-Up After Enable (TPS61058)	14
	Overvoltage Protection (TPS61058)	15
	Duty Cycle Jitter (TPS61058)	16

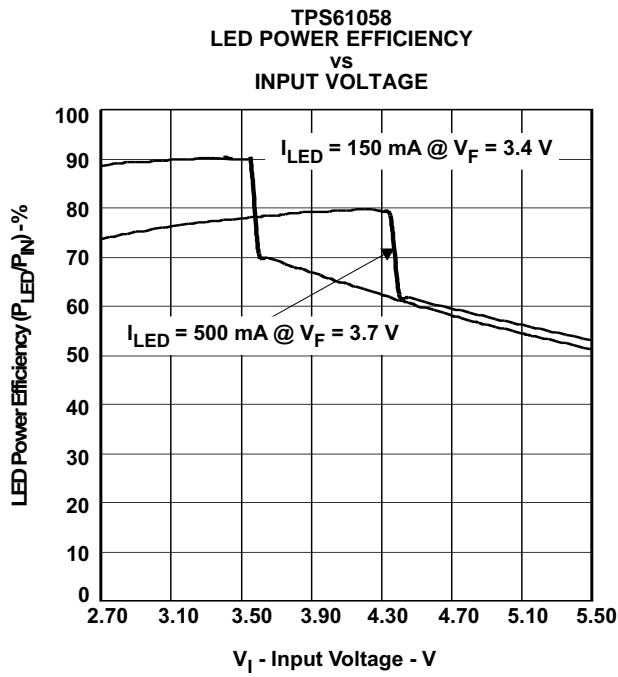

Figure 3.

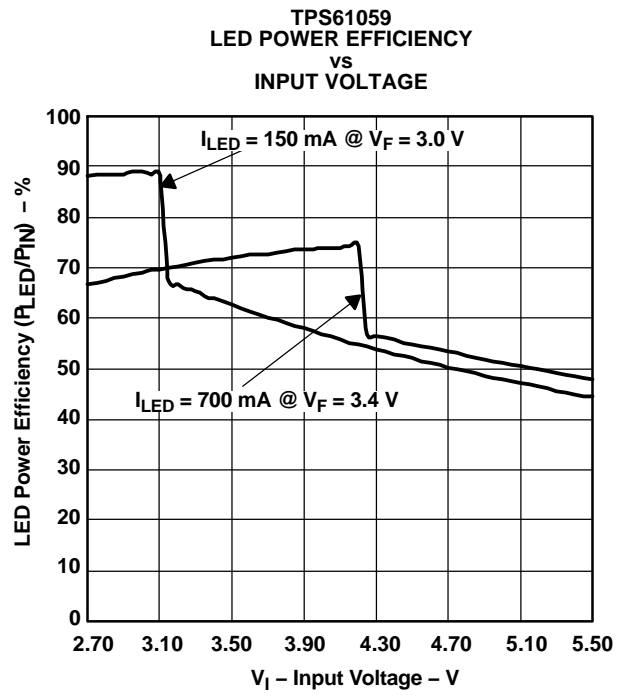

Figure 4.

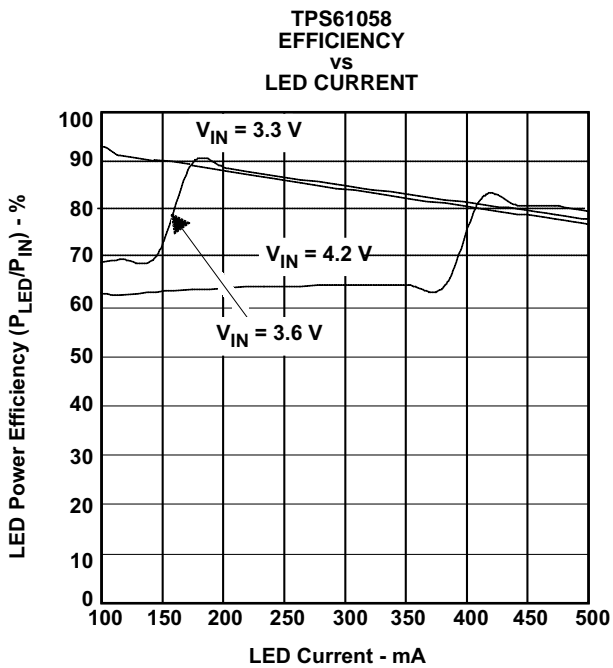

Figure 5.

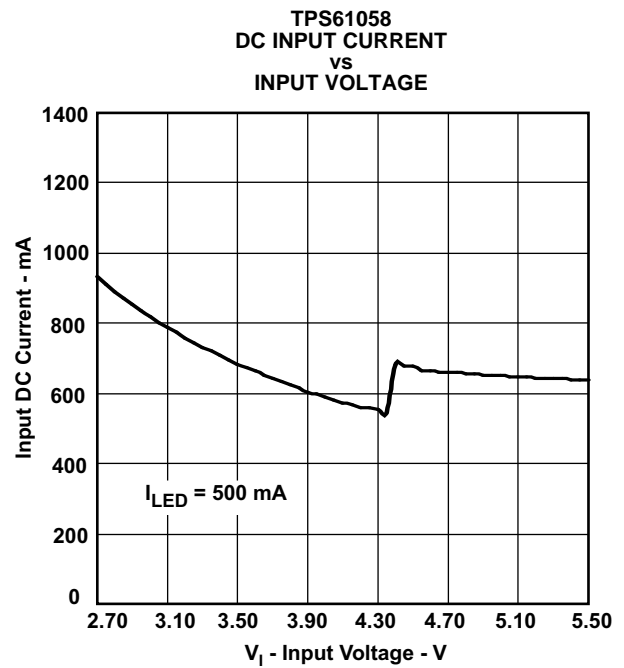

Figure 6.

TPS61058  
TPS61059

SLVS572B – APRIL 2005 – REVISED DECEMBER 2005

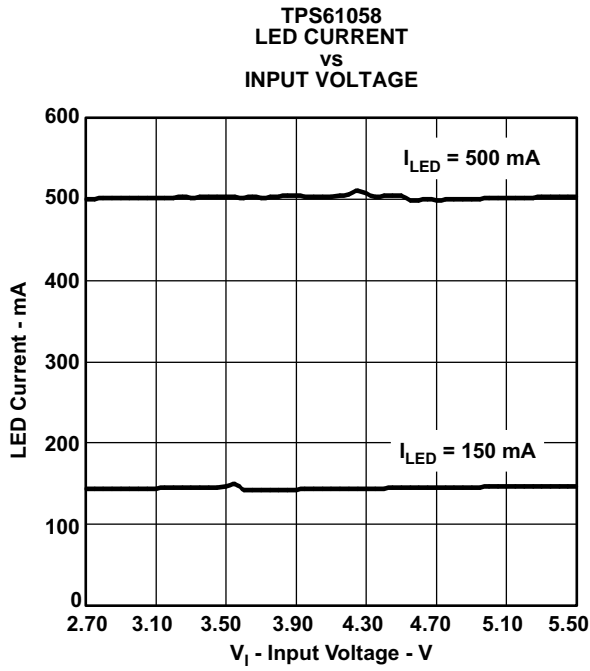

Figure 7.

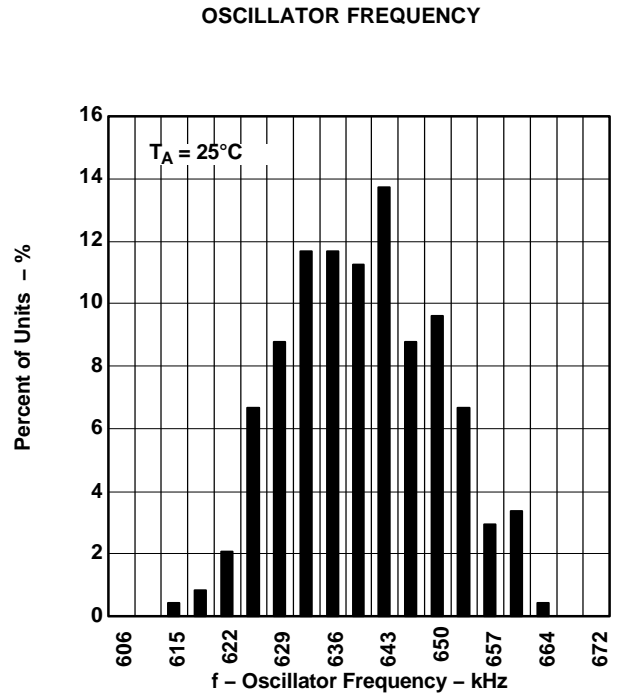

Figure 8.

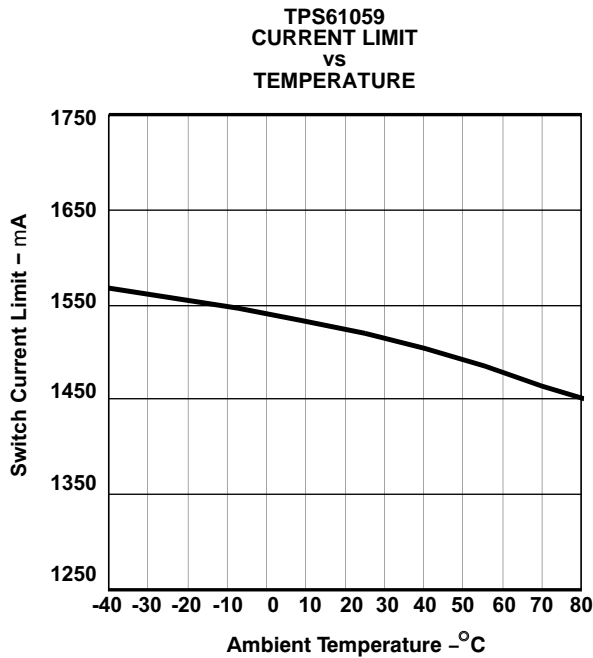

Figure 9.

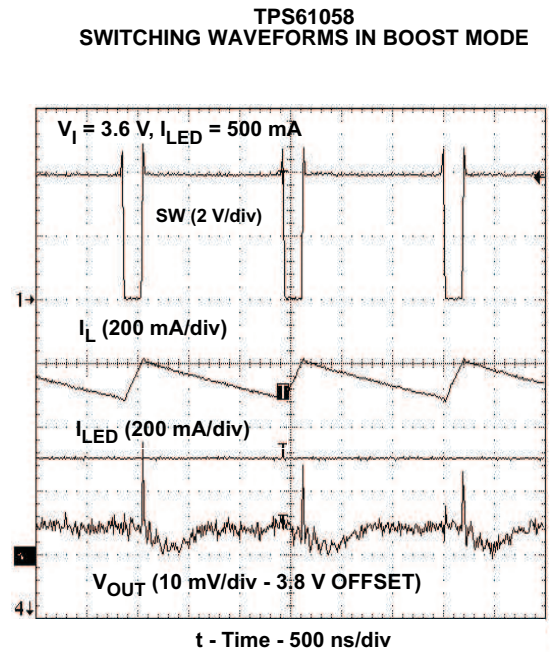

Figure 10.

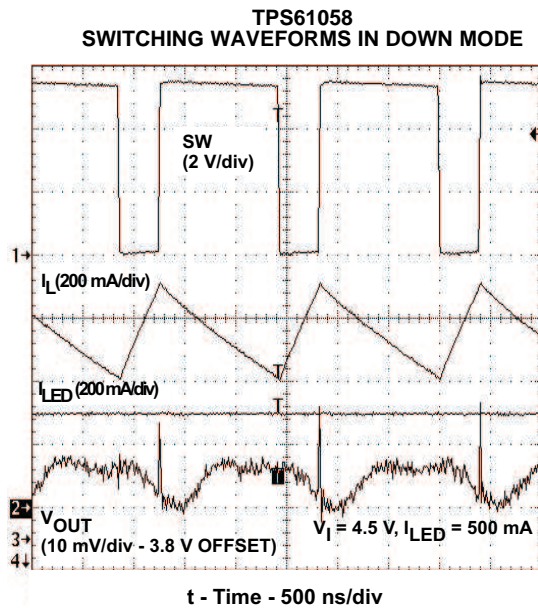

Figure 11.

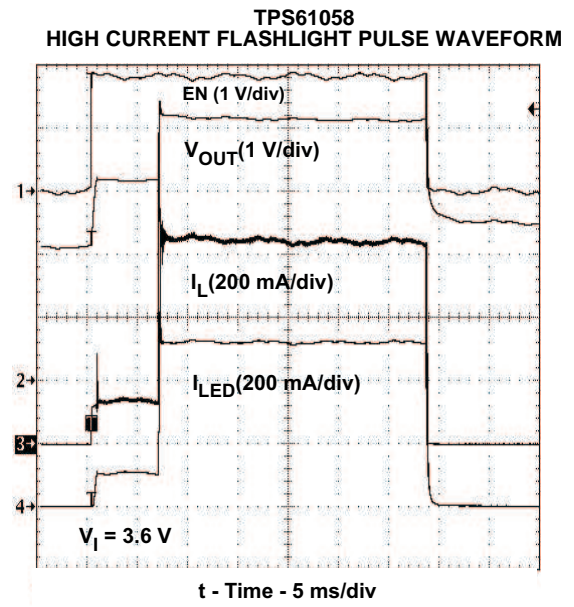

Figure 12.

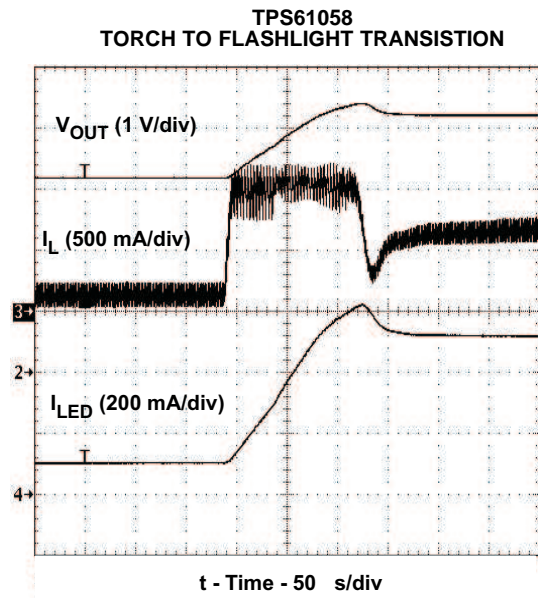

Figure 13.

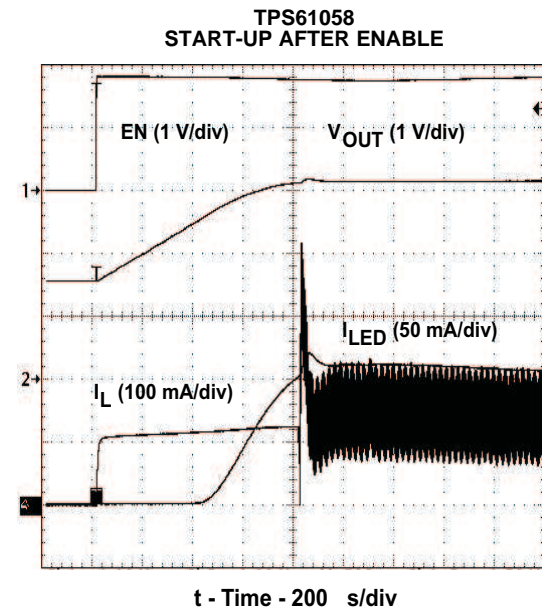

Figure 14.

TPS61058  
TPS61059

SLVS572B–APRIL 2005–REVISED DECEMBER 2005

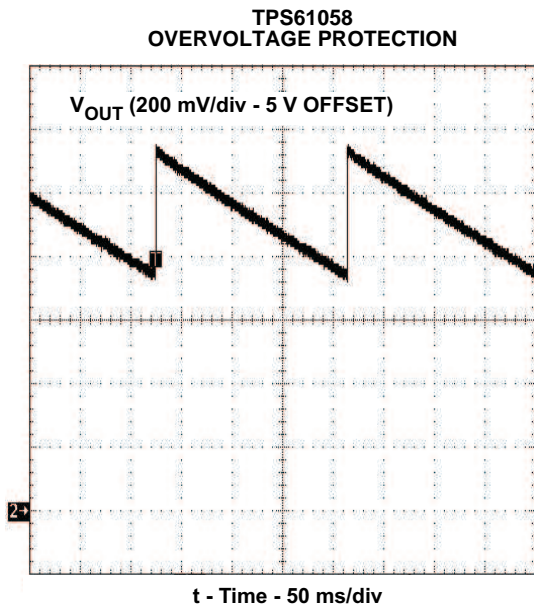

Figure 15.

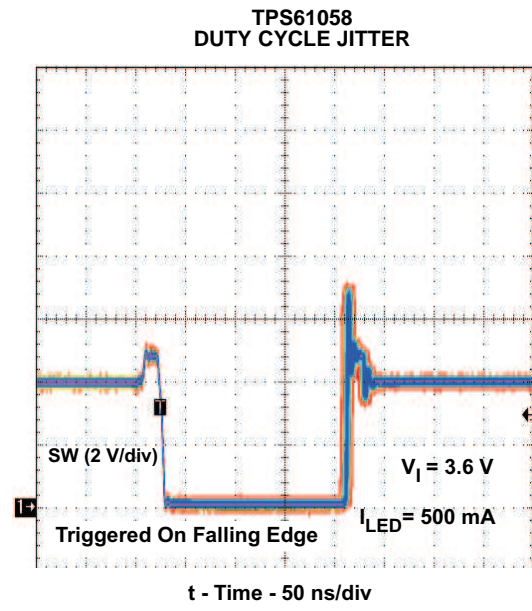

Figure 16.

---

## DETAILED DESCRIPTION

### OPERATION

The TPS61058/9 family is based on a fixed frequency multiple feedforward controller topology. Input voltage, output voltage, and voltage drop on the NMOS switch are monitored and forwarded to the regulator. So changes in the operating conditions of the converter directly affect the duty cycle and must not take the indirect and slow way through the control loop and the error amplifier.

The control loop, determined by the error amplifier, only has to handle small signal errors. The input for it is the feedback voltage on the FB pin. It is compared with the internal reference voltage to generate an accurate and stable LED current.

The peak current of the NMOS switch is also sensed to limit the maximum current flowing through the switch and the inductor. The typical peak current limit is set to 1000mA (TPS61058) and 1500 mA (TPS61059). An internal temperature sensor prevents the device from getting overheated in case of excessive power dissipation.

### Synchronous Rectifier

The device integrates an N-channel and a P-channel MOSFET transistor to realize a synchronous rectifier. Because the commonly used discrete Schottky rectifier is replaced with a low RDS(ON) PMOS switch, the power conversion stage itself can reach 96% efficiency.

In order to avoid ground shift due to the high currents in the NMOS switch, two separate ground pins are used. The reference for all control functions is the GND pin. The source of the NMOS switch is connected to PGND. Both grounds must be connected on the PCB at only one point close to the GND pin.

A special circuit is applied to disconnect the load from the input during shutdown of the converter. In conventional synchronous rectifier circuits, the backgate diode of the high-side PMOS is forward biased in shutdown and allows current flow from the battery to the output. This device however uses a special circuit which takes the cathode of the backgate diode of the high-side PMOS and disconnects it from the source when the regulator is not enabled (EN = Low).

The benefit of this feature for the system design engineer is that the battery is not depleted during shutdown of the converter. No additional components have to be added to the design to make sure that the battery is disconnected from the output of the converter.

### Down Regulation

In general, a boost converter only regulates output voltages which are higher than the input voltage. This device operates differently and is capable of driving high power single die white LEDs from a fully charged Li-Ion cell. To control this applications properly, a down conversion mode is implemented.

If the input voltage reaches or exceeds the output voltage necessary to maintain the LED current within regulation, the converter changes to a down conversion mode. In this mode, the control circuit changes the behavior of the rectifying PMOS transistor. It sets the voltage drop across the PMOS as high as needed to regulate the output voltage. This means the power losses in the converter increase. This has to be taken into account for thermal consideration especially when operating with low  $V_F$  LEDs, high battery voltages and high LED currents.

### Enable

The device is put into operation when EN is set high. It is put into a shutdown mode when EN is set to GND. The EN input pin has an internal 400-k $\Omega$  pull-down resistor to disable the device when this pin is floating.

In shutdown mode, the regulator stops switching, the internal control circuitry is switched off, and the load is isolated from the input (as described in the Synchronous Rectifier Section). This also means that the output voltage can drop below the input voltage during shutdown.

**DETAILED DESCRIPTION (continued)****Softstart**

To avoid high inrush current during start-up, special care is taken to control the inrush current. When the device is first enabled, the output capacitor is charged with a constant pre-charge current of 115mA (typ) until either the output voltage is typically 0.1V below the input voltage or the feedback voltage is 500mV (typ). The rectifying switch is current limited during the pre-charge phase. This also limits the output current under short circuit conditions at the output.

The fixed pre-charge current during start-up allows the device to start up without problems when driving single die white LEDs as long as the LED start-up current is set to a value lower than the pre-charge current (84 mA min.). Refer to the application section for more details.

When the device has finished start-up and is ready for high current operation, the device forces IOK output to ground, starts switching and regulates the LED current to the desired value (e.g. torch or flashlight current level).

**Overvoltage Protection (OVP)**

As with any current source, the output voltage rises when the load becomes high impedance or gets disconnected. To prevent the output voltage exceeding the maximum switch voltage rating (7 V) of the main switch, an overvoltage protection circuit is integrated. As soon as the output voltage exceeds the OVP threshold, the converter stops switching and the output voltage decreases. When the output voltage falls below the OVP threshold, the converter continues operation until the output voltage exceeds the OVP threshold again.

**Efficiency and Sense Voltage**

The voltage across the sense resistor ( $R_S$ ) has a direct effect of the converter efficiency. Because the sense voltage does not contribute to the output power ( $P_{LED}$ ), the lower this voltage the higher the efficiency. It is therefore recommended to operate with a sense voltage of approximately 0.75V at maximum LED current.

**Thermal Shutdown**

An internal thermal shutdown is implemented and turns off the internal MOSFETs when the typical junction temperature of 140°C is exceeded. The thermal shutdown has a hysteresis of typically 20°C. Refer to the *Thermal Information* section.

## APPLICATION INFORMATION

## DESIGN PROCEDURE

The standard application circuit (Figure 17) of the TPS61058/9 is a complete solution to drive high-power white LEDs with two discrete current steps.

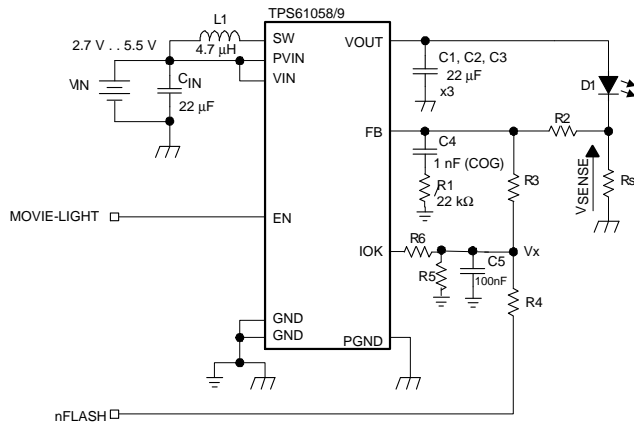

Figure 17. Typical Application

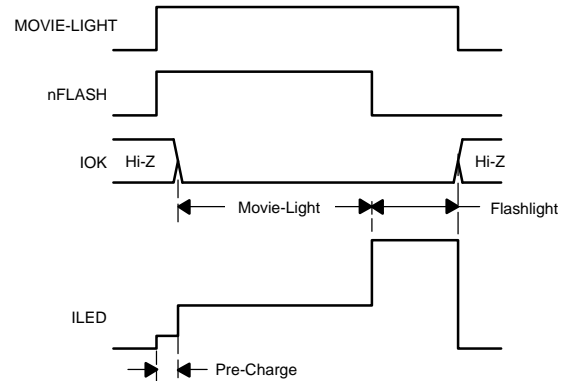

Figure 18. Waveform Profiles

The LED current is programmed using external resistors ( $R_S$ ,  $R_2$ ,  $R_3$ ,  $R_4$ ,  $R_5$ , and  $R_6$ ). The first step to turn on the LED is to enable the device ( $EN = \text{High}$ ). After charging the output capacitor, the device forces  $I_{OK}$  to ground, starts switching, and regulates the LED current to the desired value. The control signal,  $nFLASH$ , injects current into the feedback network through  $R_4$ , thereby, changing the LED current. For this reason, the  $nFLASH$  control signal needs at least to be biased up until  $I_{OK}$  goes low. In case this is not done properly the converter stays stuck in the pre-charge phase.

To facilitate the sizing of the external resistor network, it is recommended to use the calculation sheet available in the device product folder.

1. Sense resistor,  $R_S$ 

The voltage across the sense resistor should be set to approximately 0.75 V at maximum LED current.

$$R_S = \frac{V_{SENSE}}{I_{LED}} \quad (1)$$

Check the power rating of the sense resistor ( $P_D = R_S \times I_{LED}^2$ ).

## 2. LED current setting

Figure 19 shows an equivalent circuit for the feedback network. The regulation loop is using an external control voltage ( $nFLASH$ ) to set the LED current. With the help of this voltage the feedback bias current ( $I_{BIAS}$ ) can be adjusted which, in effect, controls the LED current without changing any externals.

In most applications a variable control voltage is not available to set the LED current. In practical applications,  $nFLASH$  can either be:

A constant bias voltage (2.8 V for example) which in combination with  $I_{OK}$  can be used to switch between two LED currents (Off, Flashlight).

A logic signal generated by the imaging processor. This configuration permits three different LED currents: Off, Movie-light ( $nFLASH = \text{High}$ ), Flashlight ( $nFLASH = \text{Low}$ ).

**TPS61058**  
**TPS61059**

SLVS572B–APRIL 2005–REVISED DECEMBER 2005

The circuit operation can be split into different phases:

1. Pre-Charge Phase (IOK = Hi-Z)

During this phase IOK is kept high-impedance. For proper startup the external loop components need to be chosen so that the regulation loop can settle for a maximum LED current of less than 84 mA. This can be achieved by increasing the bias voltage ( $V_x$ ) of the feedback network.

$$I_{LED} = \frac{0.5 - (R2 \times I_{BIAS})}{R_S} \quad (2)$$

$$I_{BIAS} \approx \frac{R5}{R3 \times (R4 + R5)} nFLASH - \frac{0.5}{R3}, \text{ assuming } R4//R5 \text{ is small compared } R3. \quad (3)$$

2. High-Current Operation (IOK = GND)

After the pre-charge phase, IOK is automatically pulled to ground. This modifies the feedback divider network changing the potential of the  $V_x$  node. As a consequence the LED current is adjusted accordingly.

$$I_{LED} = \frac{0.5 - (R2 \times I_{BIAS2})}{R_S} \approx \frac{1}{2 \times R_S} + \frac{R2}{2 \times R3 \times R_S} - \frac{R2}{R3 \times R_S} V_x \quad (4)$$

$$I_{BIAS2} \approx \frac{R5'}{R3 \times (R4 + R5')} nFLASH - \frac{0.5}{R3}, \text{ with } R5' = \frac{R5 \times R6}{R5 + R6} \quad (5)$$

For operation at maximum LED current (flashlight mode), nFLASH needs to be set to ground level.

$$I_{LED(FLASH)} \approx \frac{R2 + R3}{2 \times R3 \times R_S}, \text{ assuming } R4//R5//R6 \text{ is small compared } R3. \quad (6)$$

For operation at other LED currents (movie-light or pre-charge), nFLASH applies a positive bias voltage (1.8 V for example) to the feedback divider network. The following equations show the relationship between LED current and bias voltage  $V_x$ .

$$V_x \approx \frac{1}{2} + \frac{R3}{2 \times R2} - I_{LED(MOVIE-LIGHT, PRE-CHARGE)} \frac{R3 + R_S}{R2} \quad (7)$$

$$V_x \approx \frac{R5'}{R4 + R5'} nFLASH, \text{ with } R5' = \frac{R5 \times R6}{R5 + R6} \quad (8)$$

For stable operation, it is recommended that R3 be set in the range of 50 kΩ to 150 kΩ and R5 in the range of 3.3 kΩ to 10 kΩ. Best performance is obtained with a pre-charge current of 45 mA typ.

For single current level applications (e.g. torch or flashlight only) it is recommended to operate with R4 in the range of 50kΩ to 200 kΩ. In that case R5 is not need anymore.

The following example is used to explain the procedure to size the external components for a given set of requirements:

- Movie-light mode:  $I_{LED} = 150 \text{ mA}$
- Flashlight mode:  $I_{LED} = 500 \text{ mA}$
- LED forward voltage:  $V_{F(MAX)} = 4.4 \text{ V}$  at  $500 \text{ mA}$
- nFLASH signal is  $1.8 \text{ V}$  logic compliant ( $0 \text{ V}$  and  $1.8 \text{ V} \pm 4\%$ )

Step 1 – Current Sense Resistor Calculation –  $R_S$

$$R_S = \frac{V_{SENSE}}{I_{LED}} = \frac{0.75}{0.5} = 1.5 \Omega \quad \left| \quad V_{OUT(MAX)} = 4.4 + 0.75 = 5.15 \text{ V} \right. \quad (9)$$

Step 2 – Feedback Divider Resistor Calculation –  $R_2, R_3$

$$I_{LED(FLASH)} \approx \frac{R_2 + R_3}{2 \times R_3 \times R_S} \quad \left| \quad \begin{array}{l} R_3 = 100 \text{ k}\Omega \text{ (recommended value)} \\ R_2 = 47 \text{ k}\Omega \text{ (calculated)} \end{array} \right. \quad (10)$$

Step 3 – Bias Resistor Network Calculation –  $R_4, R_5, R_6$

$$V_X \approx \frac{1}{2} + \frac{R_3}{2 \times R_2} - I_{LED} \frac{R_3 \times R_S}{R_2} \quad \left| \quad \begin{array}{l} V_X = 1.1 \text{ V @ } I_{LED} = 150 \text{ mA (movie-light)} \\ V_X = 1.4 \text{ V @ } I_{LED} = 45 \text{ mA (pre-load)} \end{array} \right. \quad (11)$$

During the pre-charge phase, IOK is high impedance.

$$V_X \approx \frac{R_5}{R_4 + R_5} \text{ nFLASH} \quad \left| \quad \begin{array}{l} \frac{R_5}{R_4 + R_5} = 0.78 \\ R_5 = 10 \text{ k}\Omega \text{ (recommended value)} \\ R_4 = 2.7 \text{ k}\Omega \text{ (calculated)} \end{array} \right. \quad (12)$$

In movie-light mode, IOK is grounded.

$$V_X \approx \frac{R_5'}{R_4 + R_5'} \text{ nFLASH} \quad \left| \quad \begin{array}{l} \frac{R_5'}{R_4 + R_5'} = 0.61, R_5' = 1.57 \times R_4, R_5' = \frac{R_5 \times R_6}{R_5 + R_6} \\ R_6 = 7.5 \text{ k}\Omega \text{ (calculated)} \end{array} \right. \quad (13)$$

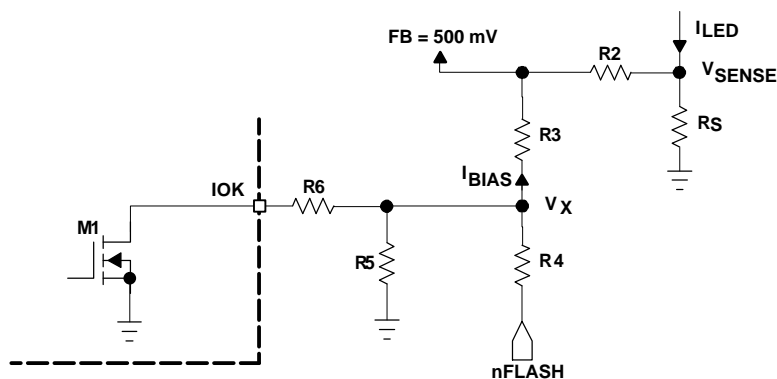

Figure 19. Feedback Network Equivalent Circuit

## TPS61058

## TPS61059

SLVS572B–APRIL 2005–REVISED DECEMBER 2005

### INDUCTOR SELECTION

A boost converter normally requires two main passive components for storing energy during the conversion. A boost inductor and a storage capacitor at the output are required. To select the boost inductor, it is recommended to keep the possible peak inductor current below the current limit threshold of the power switch in the chosen configuration. For example, the current limit threshold of the TPS61059 switch is 1700 mA at an output voltage of 5 V. The highest peak current through the inductor and the switch depends on the output load, the input voltage and the output voltage. Estimation of the maximum average inductor current can be done using [Equation 14](#):

$$I_L = I_{OUT} \times \frac{V_{OUT}}{V_{IN} \times 0.8} \quad (14)$$

$$V_{OUT} = V_{F(LED)} + R_S \times I_{LED} \quad (15)$$

For example, for an output current of 500 mA at 4.5 V, at least 800 mA of average current flows through the inductor at a minimum input voltage of 3.3 V.

The second parameter for choosing the inductor is the desired current ripple in the inductor. In order to optimized the solution size, inductor ripple currents as high as 40% of the average inductor current can be tolerated. A smaller ripple reduces the magnetic hysteresis losses in the inductor, as well as output voltage ripple and EMI. With those parameters, it is possible to calculate the value for the inductor by using [Equation 16](#):

$$L = \frac{V_{IN} \times (V_{OUT} - V_{IN})}{\Delta I_L \times f \times V_{OUT}} \quad (16)$$

Parameter  $f$  is the switching frequency and  $\Delta I_L$  is the ripple current in the inductor, i.e.,  $40\% \times I_L$ . In this example, the desired inductor has the value of 4.5  $\mu\text{H}$ . With this calculated value and the calculated currents, it is possible to choose a suitable inductor. In typical high current white LED applications a 4.7  $\mu\text{H}$  inductance is recommended. Care has to be taken that load transients and losses in the circuit can lead to higher currents as estimated in [Equation 16](#). Also, the losses in the inductor caused by magnetic hysteresis losses and copper losses are a major parameter for total circuit efficiency.

The following inductor series from different suppliers have been used with the TPS61058/9 converters:

**Table 1. List of Inductors**

MANUFACTURER	SERIES	DIMENSIONS	REMARKS
COILCRAFT	LPS3015	3 mm x 3 mm x 1.5 mm max. height	TPS61058
TDK	VLF3014AT	2.6 mm x 2.8 mm x 1.4 mm max. height	TPS61058
	VLF5014AT	4.5 mm x 4.7 mm x 1.4 mm max. height	TPS61059
TAIYO YUDEN	NP04SZB	5 mm x 5 mm x 2.0 mm max. height	TPS61059

## CAPACITOR SELECTION

### Input Capacitor

For good input voltage filtering low ESR ceramic capacitors are recommended. At least a 10- $\mu$ F input capacitor is recommended to improve transient behavior of the regulator and EMI behavior of the total power supply circuit. The input capacitor should be placed as close as possible to the input pin of the converter.

### Output Capacitor

The major parameter necessary to define the output capacitor is the maximum allowed output voltage ripple of the converter. This ripple is determined by two parameters of the capacitor, the capacitance and the ESR. It is possible to calculate the minimum capacitance needed for the defined ripple, supposing that the ESR is zero, by using [Equation 17](#):

$$C_{\min} = \frac{I_{\text{OUT}} \times (V_{\text{OUT}} - V_{\text{IN}})}{f \times \Delta V \times V_{\text{OUT}}} \quad (17)$$

Parameter  $f$  is the switching frequency and  $\Delta V$  is the maximum allowed ripple.

With a chosen ripple voltage of 10 mV, a minimum capacitance of 22  $\mu$ F is needed. The total ripple is larger due to the ESR of the output capacitor. This additional component of the ripple can be calculated using [Equation 18](#):

$$\Delta V_{\text{ESR}} = I_{\text{OUT}} \times R_{\text{ESR}} \quad (18)$$

The total ripple is the sum of the ripple caused by the capacitance and the ripple caused by the ESR of the capacitor. Additional ripple is caused by load transients. This means that the output capacitor has to completely supply the load during the charging phase of the inductor. A reasonable value of the output capacitance depends on the speed of the load transients and the load current during the load change.

For the high current white LED application, a minimum of 20  $\mu$ F effective output capacitance is usually required when operating with 4.7  $\mu$ H (typ) inductors. For solution size reasons, this is usually one or more X5R/X7R ceramic capacitors. In order to maintain the control loop stable, the addition of a compensation network formed by R1 (22 k $\Omega$ ) and C3 (1 nF COG) is necessary.

## CHECKING LOOP STABILITY

The first step of circuit and stability evaluation is to look from a steady-state perspective at the following signals:

- Switching node, SW
- Inductor current,  $I_L$
- Output ripple voltage,  $V_{\text{OUT(AC)}}$

These are the basic signals that need to be measured when evaluating a switching converter. When the switching waveform shows large duty cycle jitter or the output voltage or inductor current shows oscillations, the regulation loop may be unstable. This is often a result of board layout and/or L-C combination.

As a next step in the evaluation of the regulation loop, the load transient response is tested.  $V_{\text{OUT}}$  can be monitored for settling time, overshoot or ringing that helps judge the converter's stability. Without any ringing, the loop has usually more than 45° of phase margin.

Because the damping factor of the circuitry is directly related to several resistive parameters (e.g., MOSFET  $r_{\text{DS(on)}}$ ) that are temperature dependant, the loop stability analysis has to be done over the input voltage range, LED current range, and temperature range.

TPS61058  
TPS61059

SLVS572B–APRIL 2005–REVISED DECEMBER 2005

LAYOUT CONSIDERATIONS

As for all switching power supplies, the layout is an important step in the design, especially at high peak currents and high switching frequencies. If the layout is not carefully done, the regulator could show stability problems as well as EMI problems. Therefore, use wide and short traces for the main current path and for the power ground tracks.

The input capacitor, output capacitor, and the inductor should be placed as close as possible to the IC. Use a common ground node for power ground and a different one for control ground to minimize the effects of ground noise. Connect these ground nodes at any place close to one of the ground pins of the IC.

The compensation network as well as the current setting resistors should be placed as close as possible to the control ground pin of the IC. To lay out the control ground, it is recommended to use short traces as well, separated from the power ground traces. This avoids ground shift problems, which can occur due to superimposition of power ground current and control ground current.

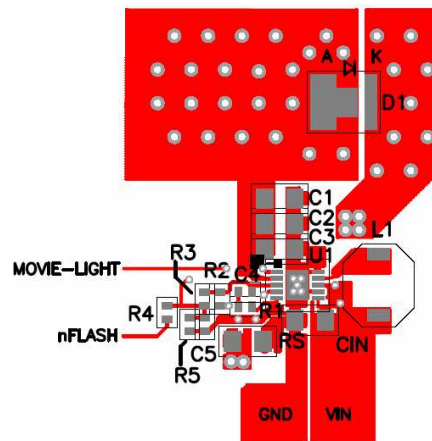

Figure 20. Suggested Layout – Top Side

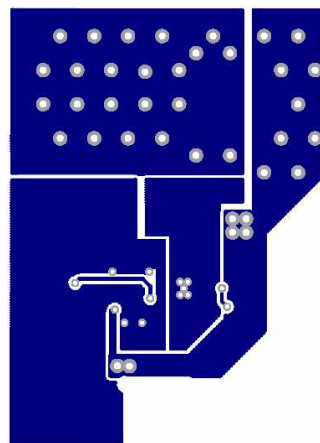
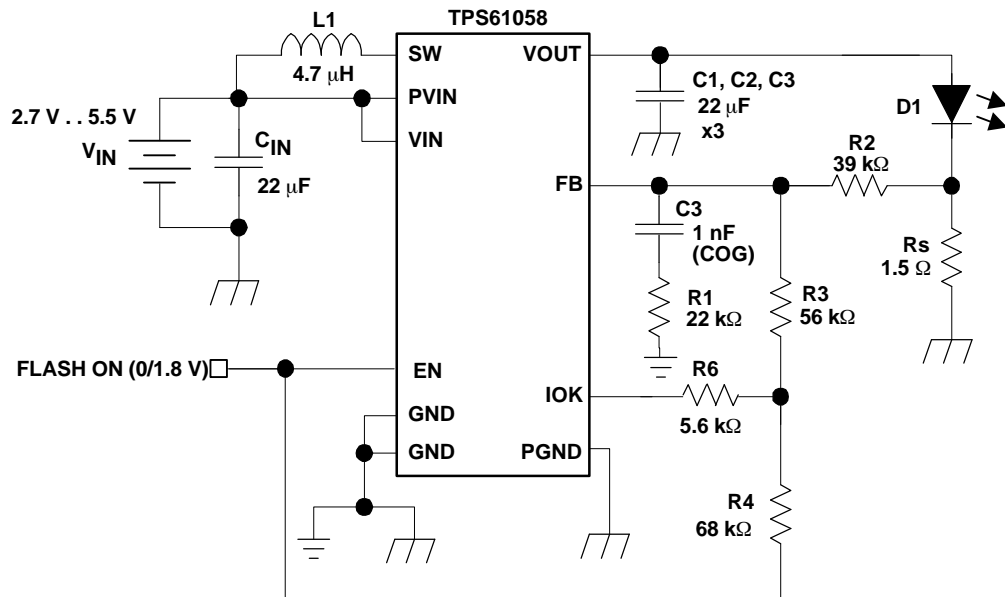

Figure 21. Suggested Layout – Bottom Side

APPLICATION EXAMPLES



List of Components:

L1 = COILCRAFT LPS3015–4R7  
C1,C2, C3 = TDK C2012X5R0J226MTJ

Figure 22. 500 mA Flashlight Application - 1.8 V Logic

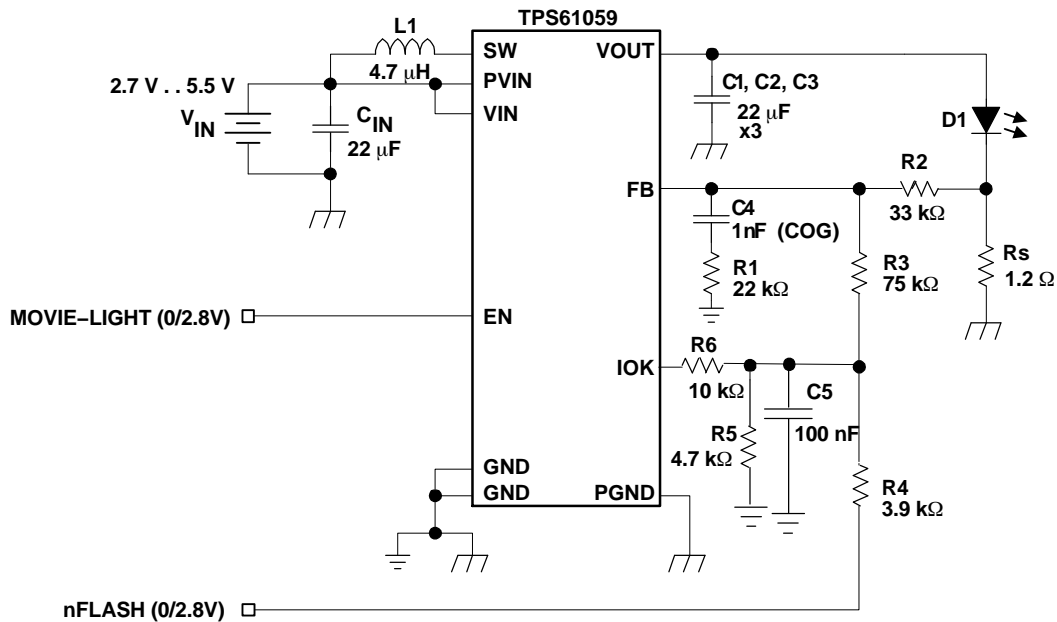

List of Components:

L1 = TDK VLF5014AT–4R7  
C1,C2, C3 = TDK C2012X5R0J226MTJ

Note: Before turning into the flashlight mode, the device to be driven into movie-light mode. See the Design Procedure section for more details.

MOVIE-LIGHT	nFLASH	ILED
0	0	OFF
0	1	OFF
1	0	FLASHLIGHT
1	1	MOVIE-LIGHT

Figure 23. 150 mA Movie-Light/600 mA Flashlight Application - 2.8 V Logic

TPS61058  
TPS61059

SLVS572B–APRIL 2005–REVISED DECEMBER 2005

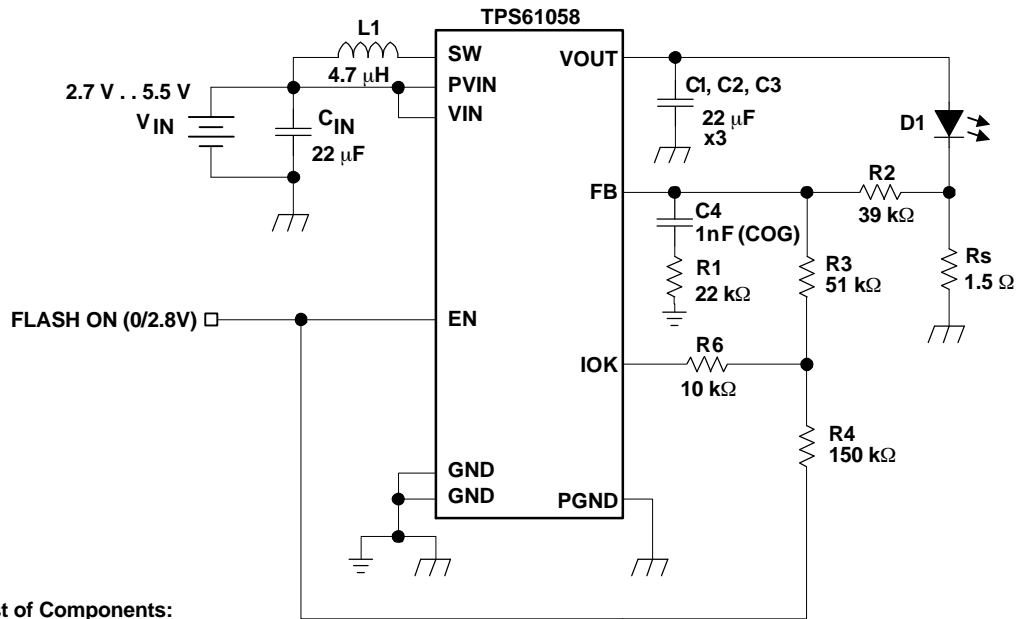

List of Components:

- L1 = COILCRAFT LPS3015-4R7
- C1,C2, C3 = TDK C2012X5R0J226MTJ

Figure 24. 500 mA Flashlight Application - 2.8 V Logic

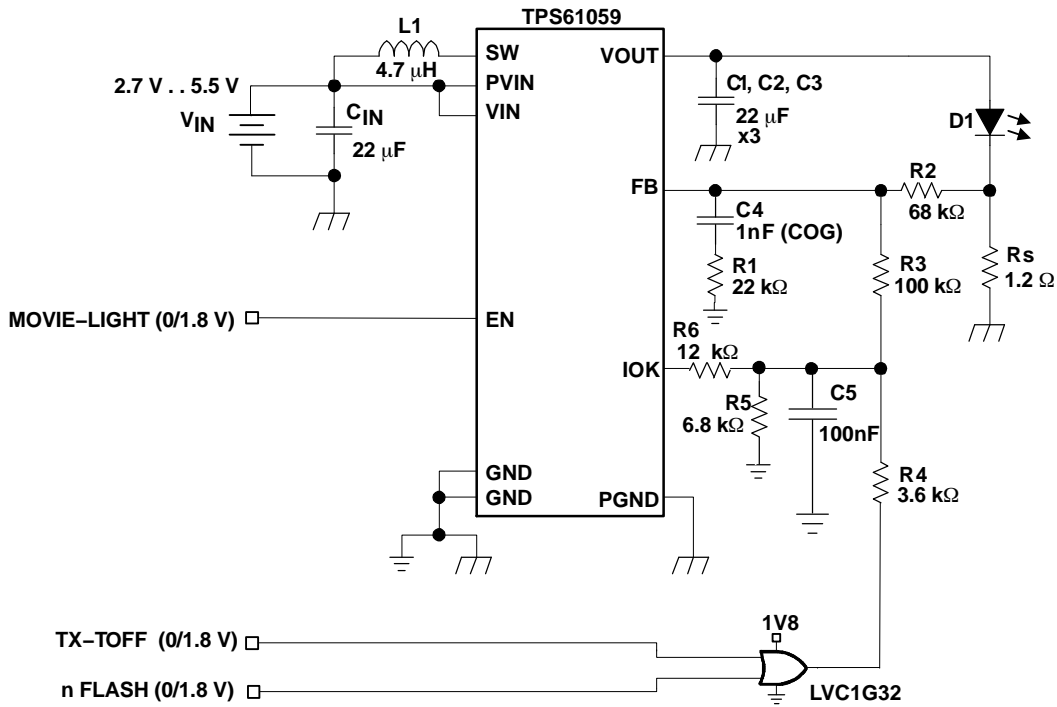

List of Components:

- L1 = TDK VLF5014AT-4R7
- C1,C2, C3 = TDK C2012X5R0J226MTJ

Figure 25. 150 mA Movie-Light/700 mA Flashlight with No-Latency Current Reduction

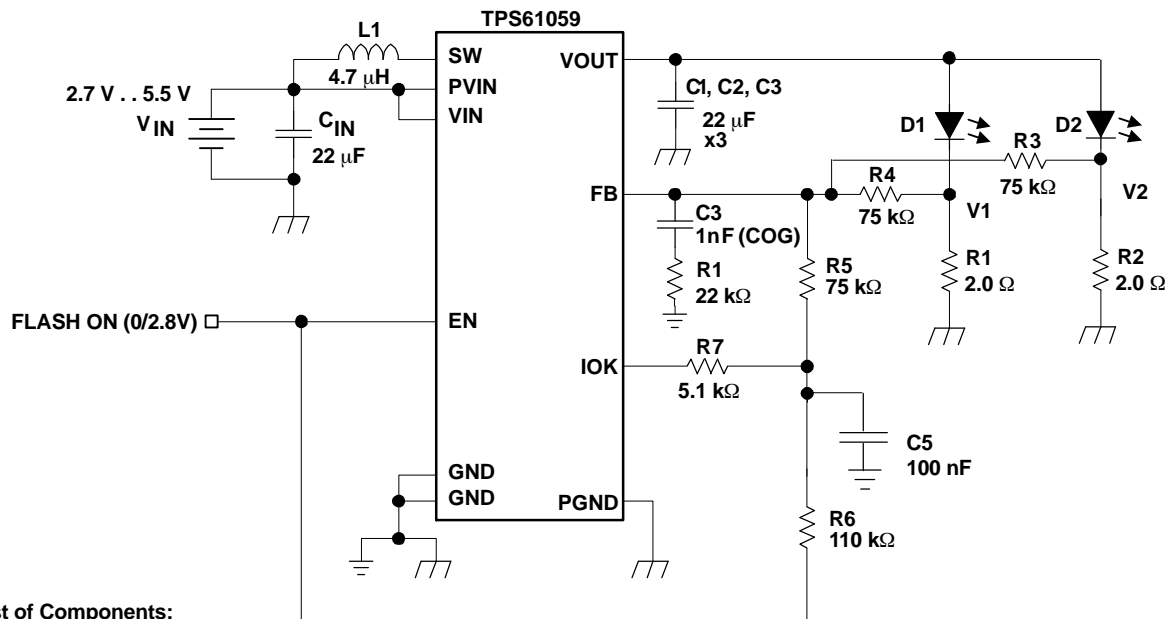

List of Components:

L1 = TDK VLF5014AT-4R7

C1,C2, C3 = TDK C2012X5R0J226MTJ

Figure 26. 2x 350 mA Flashlight Application - 2.8 V Logic

TPS61058

TPS61059

SLVS572B–APRIL 2005–REVISED DECEMBER 2005

---

**THERMAL INFORMATION**

Implementation of integrated circuits in low-profile and fine-pitch surface-mount packages typically requires special attention to power dissipation. Many system-dependent issues such as thermal coupling, airflow, added heat sinks and convection surfaces, and the presence of other heat-generating components affect the power-dissipation limits of a given component.

Three basic approaches for enhancing thermal performance are listed below.

- Improving the power dissipation capability of the PCB design
- Improving the thermal coupling of the component to the PCB
- Introducing airflow in the system

The maximum recommended junction temperature ( $T_J$ ) of the TPS61058/9 devices is 125°C. The thermal resistance of the 10-pin QFN 3 x 3 package (DRC) is  $R_{\theta JA} = 48.7 \text{ }^\circ\text{C/W}$ , if the PowerPAD is soldered. Specified regulator operation is assured to a maximum ambient temperature  $T_A$  of 85°C. Therefore, the maximum power dissipation is about 820 mW. More power can be dissipated if the maximum ambient temperature of the application is lower.

$$P_{D(\text{MAX})} = \frac{T_{J(\text{MAX})} - T_A}{R_{\theta JA}} = \frac{125^\circ\text{C} - 85^\circ\text{C}}{48.7 \text{ }^\circ\text{C/W}} = 820 \text{ mW} \quad (19)$$

## PACKAGING INFORMATION

Orderable Device	Status (1)	Package Type	Package Drawing	Pins	Package Qty	Eco Plan (2)	Lead/Ball Finish (6)	MSL Peak Temp (3)	Op Temp (°C)	Device Marking (4/5)	Samples
TPS61058DRCR	NRND	VSON	DRC	10	3000	Green (RoHS & no Sb/Br)	CU NIPDAU	Level-2-260C-1 YEAR	-40 to 85	BNF	
TPS61059DRCR	OBSOLETE	VSON	DRC	10		TBD	Call TI	Call TI	-40 to 85	BNG	
TPS61059DRCRG4	OBSOLETE	VSON	DRC	10		TBD	Call TI	Call TI	-40 to 85		
TPS61059DRCT	NRND	VSON	DRC	10	250	Green (RoHS & no Sb/Br)	CU NIPDAU	Level-2-260C-1 YEAR	-40 to 85	BNG	

(1) The marketing status values are defined as follows:

**ACTIVE:** Product device recommended for new designs.

**LIFEBUY:** TI has announced that the device will be discontinued, and a lifetime-buy period is in effect.

**NRND:** Not recommended for new designs. Device is in production to support existing customers, but TI does not recommend using this part in a new design.

**PREVIEW:** Device has been announced but is not in production. Samples may or may not be available.

**OBSOLETE:** TI has discontinued the production of the device.

(2) Eco Plan - The planned eco-friendly classification: Pb-Free (RoHS), Pb-Free (RoHS Exempt), or Green (RoHS & no Sb/Br) - please check <http://www.ti.com/productcontent> for the latest availability information and additional product content details.

**TBD:** The Pb-Free/Green conversion plan has not been defined.

**Pb-Free (RoHS):** TI's terms "Lead-Free" or "Pb-Free" mean semiconductor products that are compatible with the current RoHS requirements for all 6 substances, including the requirement that lead not exceed 0.1% by weight in homogeneous materials. Where designed to be soldered at high temperatures, TI Pb-Free products are suitable for use in specified lead-free processes.

**Pb-Free (RoHS Exempt):** This component has a RoHS exemption for either 1) lead-based flip-chip solder bumps used between the die and package, or 2) lead-based die adhesive used between the die and leadframe. The component is otherwise considered Pb-Free (RoHS compatible) as defined above.

**Green (RoHS & no Sb/Br):** TI defines "Green" to mean Pb-Free (RoHS compatible), and free of Bromine (Br) and Antimony (Sb) based flame retardants (Br or Sb do not exceed 0.1% by weight in homogeneous material)

(3) MSL, Peak Temp. - The Moisture Sensitivity Level rating according to the JEDEC industry standard classifications, and peak solder temperature.

(4) There may be additional marking, which relates to the logo, the lot trace code information, or the environmental category on the device.

(5) Multiple Device Markings will be inside parentheses. Only one Device Marking contained in parentheses and separated by a "~" will appear on a device. If a line is indented then it is a continuation of the previous line and the two combined represent the entire Device Marking for that device.

(6) Lead/Ball Finish - Orderable Devices may have multiple material finish options. Finish options are separated by a vertical ruled line. Lead/Ball Finish values may wrap to two lines if the finish value exceeds the maximum column width.

**Important Information and Disclaimer:** The information provided on this page represents TI's knowledge and belief as of the date that it is provided. TI bases its knowledge and belief on information provided by third parties, and makes no representation or warranty as to the accuracy of such information. Efforts are underway to better integrate information from third parties. TI has taken and

# PACKAGE OPTION ADDENDUM

30-Sep-2014

---

continues to take reasonable steps to provide representative and accurate information but may not have conducted destructive testing or chemical analysis on incoming materials and chemicals. TI and TI suppliers consider certain information to be proprietary, and thus CAS numbers and other limited information may not be available for release.

In no event shall TI's liability arising out of such information exceed the total purchase price of the TI part(s) at issue in this document sold by TI to Customer on an annual basis.

## TAPE AND REEL INFORMATION

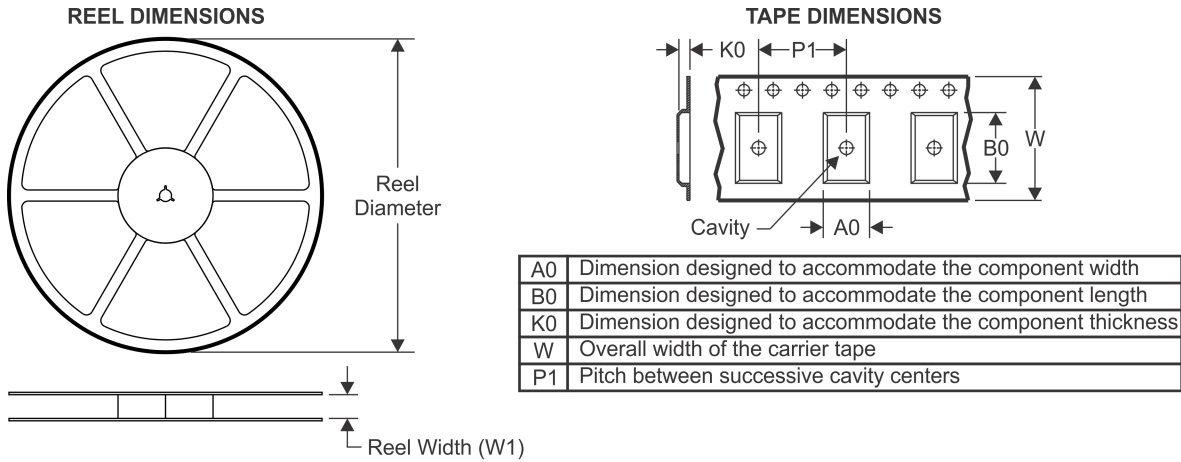

### QUADRANT ASSIGNMENTS FOR PIN 1 ORIENTATION IN TAPE

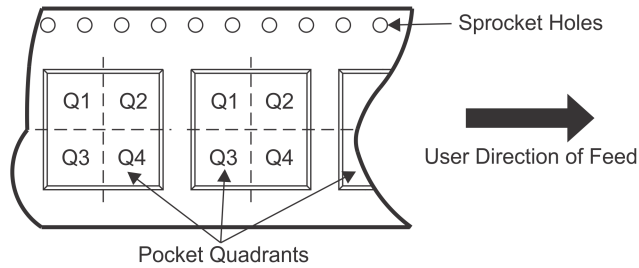

\*All dimensions are nominal

Device	Package Type	Package Drawing	Pins	SPQ	Reel Diameter (mm)	Reel Width W1 (mm)	A0 (mm)	B0 (mm)	K0 (mm)	P1 (mm)	W (mm)	Pin1 Quadrant
TPS61058DRCR	VSON	DRC	10	3000	330.0	12.4	3.3	3.3	1.1	8.0	12.0	Q2
TPS61059DRCT	VSON	DRC	10	250	180.0	12.4	3.3	3.3	1.1	8.0	12.0	Q2

## TAPE AND REEL BOX DIMENSIONS

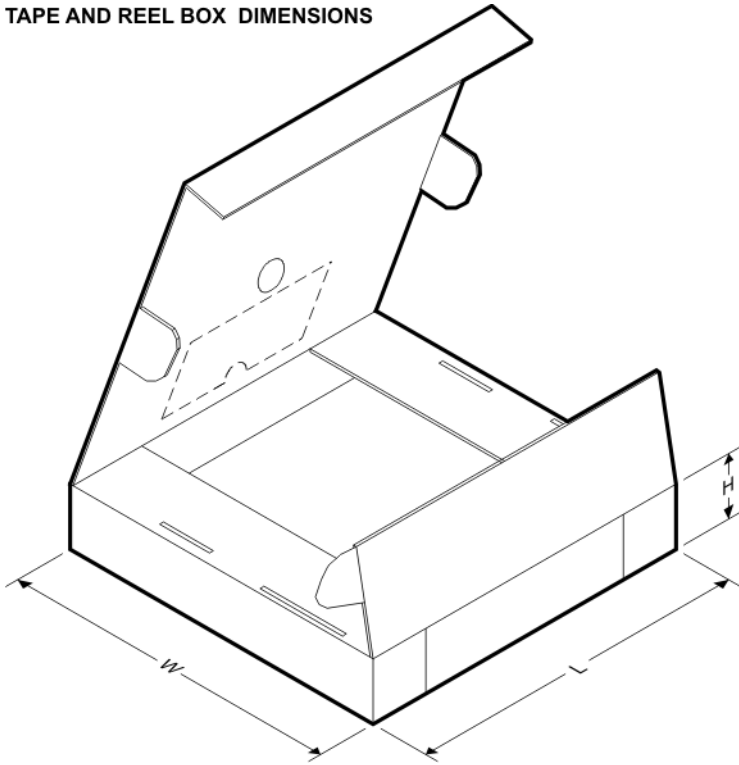

\*All dimensions are nominal

Device	Package Type	Package Drawing	Pins	SPQ	Length (mm)	Width (mm)	Height (mm)
TPS61058DRCR	VSON	DRC	10	3000	367.0	367.0	35.0
TPS61059DRCT	VSON	DRC	10	250	210.0	185.0	35.0

DRC (S-PVSON-N10)

PLASTIC SMALL OUTLINE NO-LEAD

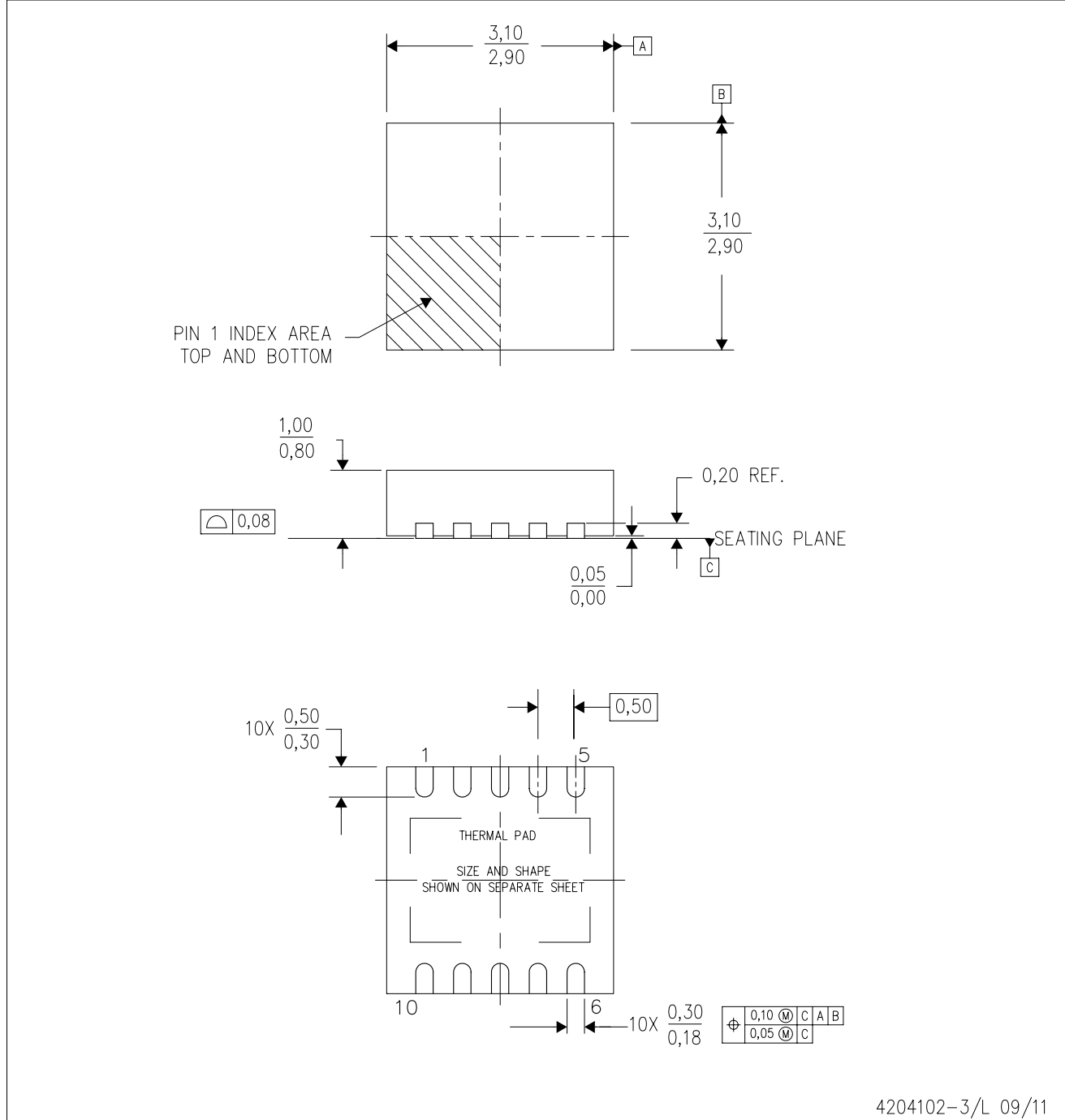

4204102-3/L 09/11

- NOTES:
- All linear dimensions are in millimeters. Dimensioning and tolerancing per ASME Y14.5M-1994.
  - This drawing is subject to change without notice.
  - Small Outline No-Lead (SON) package configuration.
  - The package thermal pad must be soldered to the board for thermal and mechanical performance, if present.
  - See the additional figure in the Product Data Sheet for details regarding the exposed thermal pad features and dimensions, if present

# THERMAL PAD MECHANICAL DATA

DRC (S-PVSON-N10)

PLASTIC SMALL OUTLINE NO-LEAD

## THERMAL INFORMATION

This package incorporates an exposed thermal pad that is designed to be attached directly to an external heatsink. The thermal pad must be soldered directly to the printed circuit board (PCB). After soldering, the PCB can be used as a heatsink. In addition, through the use of thermal vias, the thermal pad can be attached directly to the appropriate copper plane shown in the electrical schematic for the device, or alternatively, can be attached to a special heatsink structure designed into the PCB. This design optimizes the heat transfer from the integrated circuit (IC).

For information on the Quad Flatpack No-Lead (QFN) package and its advantages, refer to Application Report, QFN/SON PCB Attachment, Texas Instruments Literature No. SLUA271. This document is available at [www.ti.com](http://www.ti.com).

The exposed thermal pad dimensions for this package are shown in the following illustration.

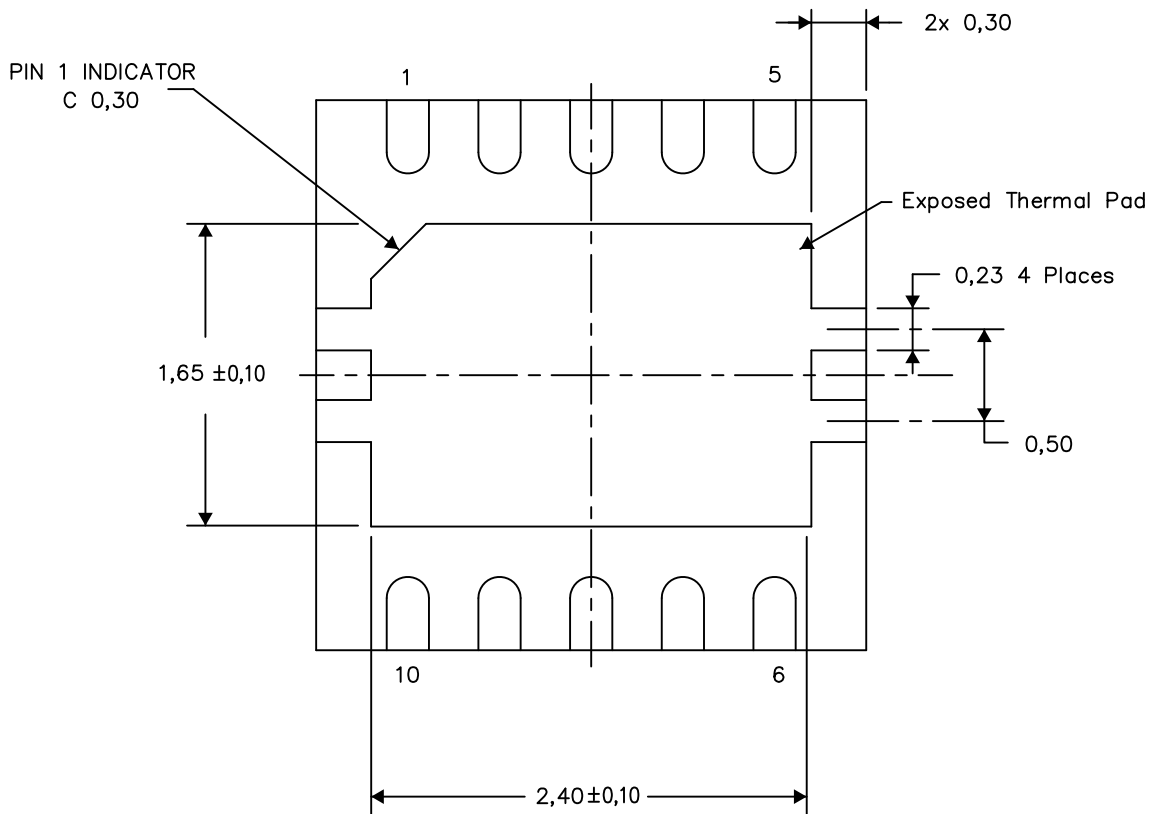

Bottom View

Exposed Thermal Pad Dimensions

4206565-3/U 04/14

NOTE: A. All linear dimensions are in millimeters

DRC (S-PVSON-N10)

PLASTIC SMALL OUTLINE NO-LEAD

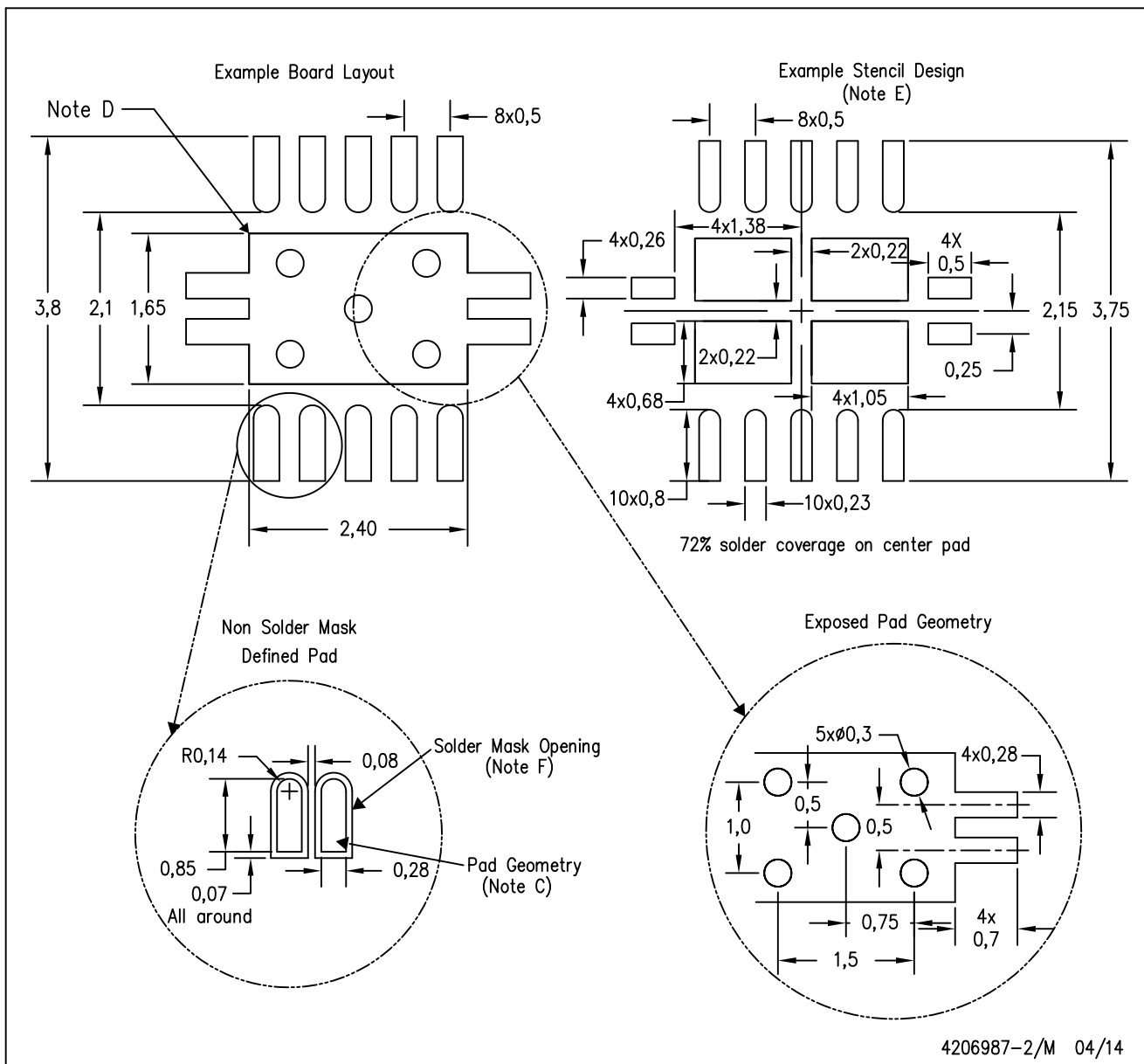

- NOTES:
- A. All linear dimensions are in millimeters.
  - B. This drawing is subject to change without notice.
  - C. Publication IPC-7351 is recommended for alternate designs.
  - D. This package is designed to be soldered to a thermal pad on the board. Refer to Application Note, Quad Flat-Pack Packages, Texas Instruments Literature No. SLUA271, and also the Product Data Sheets for specific thermal information, via requirements, and recommended board layout. These documents are available at [www.ti.com](http://www.ti.com) <<http://www.ti.com>>.
  - E. Laser cutting apertures with trapezoidal walls and also rounding corners will offer better paste release. Customers should contact their board assembly site for stencil design recommendations. Refer to IPC 7525 for stencil design considerations.
  - F. Customers should contact their board fabrication site for minimum solder mask web tolerances between signal pads.