

650-kHz/1.2-MHz 18.5-V STEP-UP DC-DC CONVERTER

Check for Samples: [TPS61085T](#)

FEATURES

- 2.3-V to 6-V Input Voltage Range
- 18.5-V Boost Converter With 2.0-A Switch Current
- 650-kHz/1.2-MHz Selectable Switching Frequency
- Adjustable Soft-Start
- Thermal Shutdown
- Undervoltage Lockout
- 8-Pin MSOP Package

APPLICATIONS

- Handheld Devices
- GPS Receiver
- Digital Still Camera
- Portable Applications
- DSL Modem
- PCMCIA Card
- TFT LCD Bias Supply

DESCRIPTION

The TPS61085 is a high-frequency high-efficiency dc-to-dc converter with an integrated 2.0-A 0.13-Ω power switch capable of providing an output voltage up to 18.5 V. The selectable frequency of 650 kHz and 1.2 MHz allows the use of small external inductors and capacitors and provides fast transient response. The external compensation allows optimizing the application for specific conditions. A capacitor connected to the soft-start pin minimizes inrush current at startup.

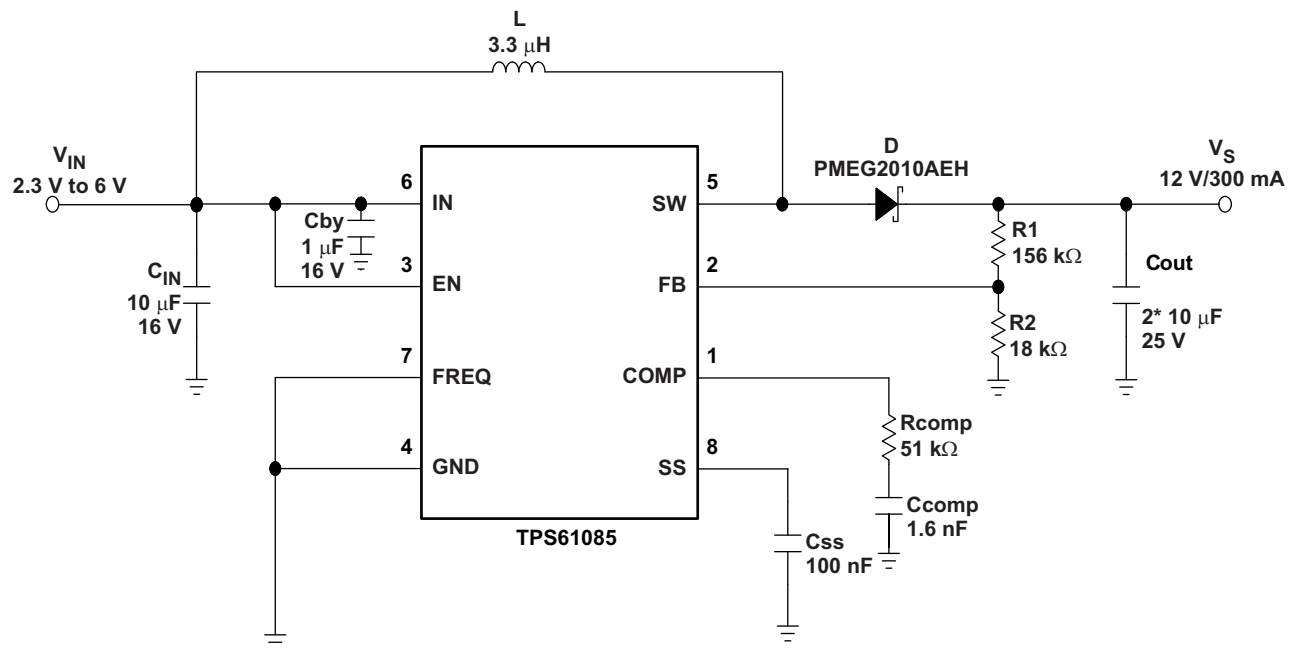

Please be aware that an important notice concerning availability, standard warranty, and use in critical applications of Texas Instruments semiconductor products and disclaimers thereto appears at the end of this data sheet.



This integrated circuit can be damaged by ESD. Texas Instruments recommends that all integrated circuits be handled with appropriate precautions. Failure to observe proper handling and installation procedures can cause damage.

ESD damage can range from subtle performance degradation to complete device failure. Precision integrated circuits may be more susceptible to damage because very small parametric changes could cause the device not to meet its published specifications.

ORDERING INFORMATION⁽¹⁾

T _A	PACKAGE ⁽²⁾		ORDERABLE PART NUMBER	TOP-SIDE MARKING
-40°C to 105°C	MSOP-8 – DGK	Reel of 2500	TPS61085TDGKR	PTQI
	TSSOP-8 – PW	Reel of 2000	TPS61085TPWR	61085T

- (1) For the most current package and ordering information, see the Package Option Addendum at the end of this document, or see the TI web site at www.ti.com.
- (2) Package drawings, thermal data, and symbolization are available at www.ti.com/packaging.

ABSOLUTE MAXIMUM RATINGS

over operating free-air temperature range (unless otherwise noted)⁽¹⁾

	VALUE	UNIT
Input voltage range I _N ⁽²⁾	-0.3 to 7	V
Voltage range on pins EN, FB, SS, FREQ, COMP	-0.3 to 7	V
Voltage on pin SW	20	V
ESD rating HBM	2	kV
ESD rating MM	200	V
ESD rating CDM	500	V
Continuous power dissipation	See Dissipation Rating Table	
Operating junction temperature range	-40 to 150	°C
Storage temperature range	-65 to 150	°C
Lead temperature (soldering, 10 sec)	260	°C

- (1) Stresses beyond those listed under *absolute maximum ratings* may cause permanent damage to the device. These are stress ratings only, and functional operation of the device at these or any other conditions beyond those indicated under *recommended operating conditions* is not implied. Exposure to absolute-maximum-rated conditions for extended periods may affect device reliability
- (2) All voltage values are with respect to network ground terminal.

DISSIPATION RATINGS^{(1) (2)}

PACKAGE	R _{θJA}	T _A ≤ 25°C POWER RATING	T _A = 70°C POWER RATING	T _A = 105°C POWER RATING
MSOP	181°C/W	552 mW	303 mW	110 mW
TSSOP	160°C/W	625 mW	343 mW	125 mW

- (1) P_D = (T_J - T_A) / R_{θJA}
- (2) R_{θJA} given for High-K PCB board

RECOMMENDED OPERATING CONDITIONS

	MIN	TYP	MAX	UNIT
V _{IN} Input voltage range	2.3		6	V
V _S Boost output voltage range	V _{IN} + 0.5		18.5	V
T _A Operating free-air temperature	-40		105	°C
T _J Operating junction temperature	-40		125	°C

ELECTRICAL CHARACTERISTICS
 $V_{IN} = 3.3\text{ V}$, $EN = IN$, $V_S = 12\text{ V}$, $T_A = -40^\circ\text{C}$ to 105°C , typical values are at $T_A = 25^\circ\text{C}$ (unless otherwise noted)

PARAMETER		TEST CONDITIONS	MIN	TYP	MAX	UNIT
SUPPLY						
V_{IN}	Input voltage range		2.3		6	V
I_Q	Operating quiescent current into IN	Device not switching, $V_{FB} = 1.3\text{ V}$		70	100	μA
I_{SDVIN}	Shutdown current into IN	$EN = \text{GND}$			1	μA
UVLO	Undervoltage lockout threshold	V_{IN} falling			2.2	V
		V_{IN} rising			2.3	V
T_{SD}	Thermal shutdown	Temperature rising		150		$^\circ\text{C}$
$T_{SD(HYS)}$	Thermal shutdown hysteresis			14		$^\circ\text{C}$
LOGIC SIGNALS EN, FREQ						
V_{IH}	High level input voltage	$V_{IN} = 2.3\text{ V}$ to 6 V	2			V
V_{IL}	Low level input voltage	$V_{IN} = 2.3\text{ V}$ to 6 V			0.5	V
I_{lkg}	Input leakage current	$EN = \text{FREQ} = \text{GND}$			0.1	μA
BOOST CONVERTER						
V_S	Boost output voltage		$V_{IN} + 0.5$		18.5	V
V_{FB}	Feedback regulation voltage		1.230	1.238	1.246	V
gm	Transconductance error amplifier			107		$\mu\text{A/V}$
I_{FB}	Feedback input bias current	$V_{FB} = 1.238\text{ V}$			0.1	μA
$R_{DS(on)}$	N-channel MOSFET on-resistance	$V_{IN} = V_{GS} = 5\text{ V}$, $I_{SW} = \text{current limit}$		0.13	0.20	Ω
		$V_{IN} = V_{GS} = 3.3\text{ V}$, $I_{SW} = \text{current limit}$		0.15	0.24	
I_{lkg}	SW leakage current	$EN = \text{GND}$, $V_{SW} = 6\text{ V}$			10	$\hat{\mu}\text{A}$
I_{LIM}	N-Channel MOSFET current limit		2.0	2.6	3.2	A
I_{SS}	Soft-start current	$V_{SS} = 1.238\text{ V}$	7	10	13	μA
f_{osc}	Oscillator frequency	FREQ = high	0.9	1.2	1.5	MHz
		FREQ = low	480	650	820	kHz
	Line regulation	$V_{IN} = 2.3\text{ V}$ to 6 V , $I_{OUT} = 10\text{ mA}$		0.0002		%/V
	Load regulation	$V_{IN} = 3.3\text{ V}$, $I_{OUT} = 1\text{ mA}$ to 400 mA		0.11		%/A

PIN ASSIGNMENT

DGK, PW PACKAGES (TOP VIEW)

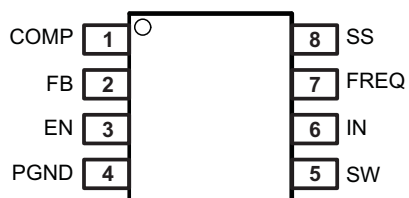

8-PIN 4.9mm x 3mm x 1.1mm MSOP (DGK)

8-PIN 6.4mm x 3mm x 1.2mm TSSOP (PW)

TERMINAL FUNCTIONS

TERMINAL		I/O	DESCRIPTION
NAME	NO.		
COMP	1	I/O	Compensation pin
FB	2	I	Feedback pin
EN	3	I	Shutdown control input. Connect this pin to logic high level to enable the device
PGND	4		Power ground
SW	5		Switch pin
IN	6		Input supply pin
FREQ	7	I	Frequency select pin. The power switch operates at 650 kHz if FREQ is connected to GND and at 1.2 MHz if FREQ is connected to IN
SS	8		Soft-start control pin. Connect a capacitor to this pin if soft-start needed. Open = no soft-start

TYPICAL CHARACTERISTICS

TABLE OF GRAPHS

			FIGURE
η	Efficiency	vs Load current, $V_S = 12\text{ V}$, $V_{IN} = 3.3\text{ V}$	Figure 1
η	Efficiency	vs Load current, $V_S = 9\text{ V}$, $V_{IN} = 3.3\text{ V}$	Figure 2
	PWM switching - discontinuous conduction		Figure 3
	PWM switching - continuous conduction		Figure 4
	Load transient response	at High frequency	Figure 5
	Load transient response	at Low frequency	Figure 6
	Soft-start		Figure 7
	Supply current	vs Supply voltage	Figure 8
	Frequency	vs Load current	Figure 9
	Frequency	vs Supply voltage	Figure 10

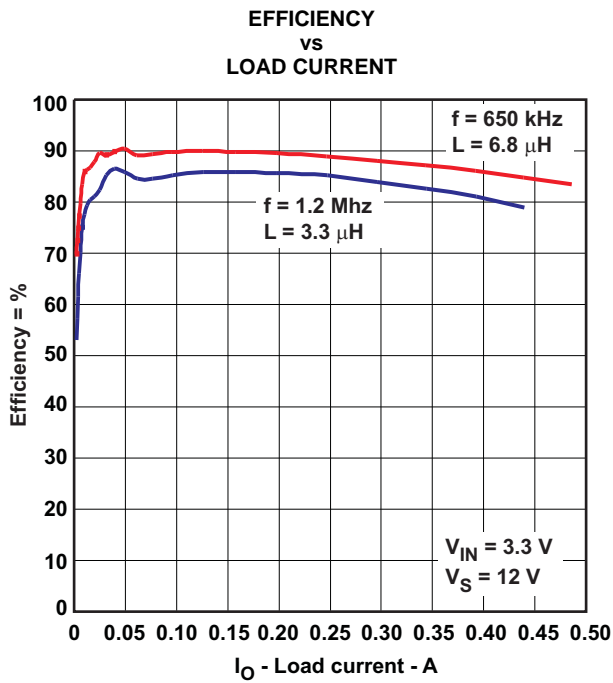

Figure 1.

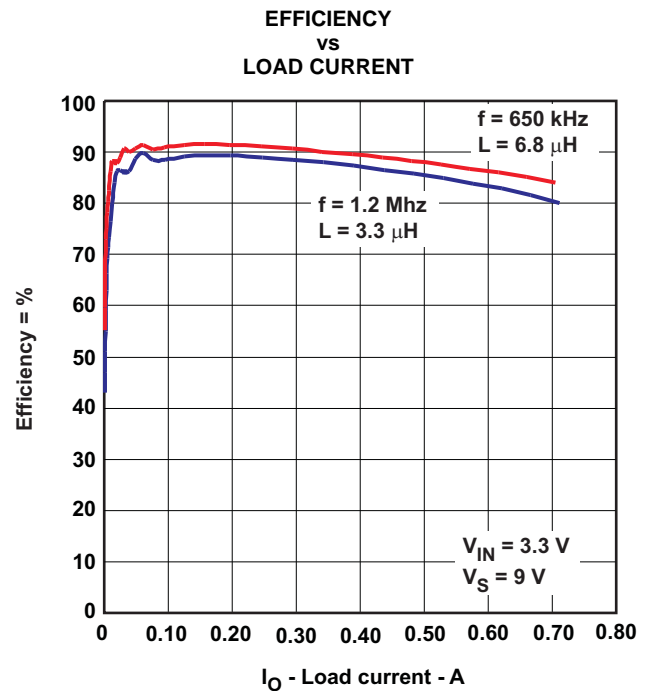

Figure 2.

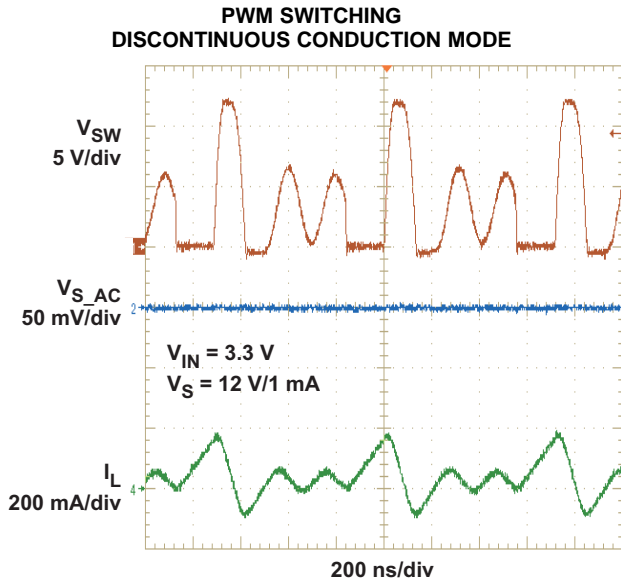

Figure 3.

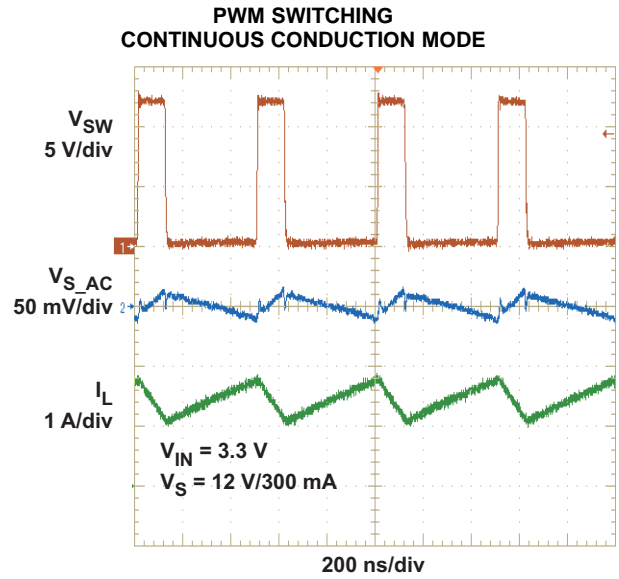

Figure 4.

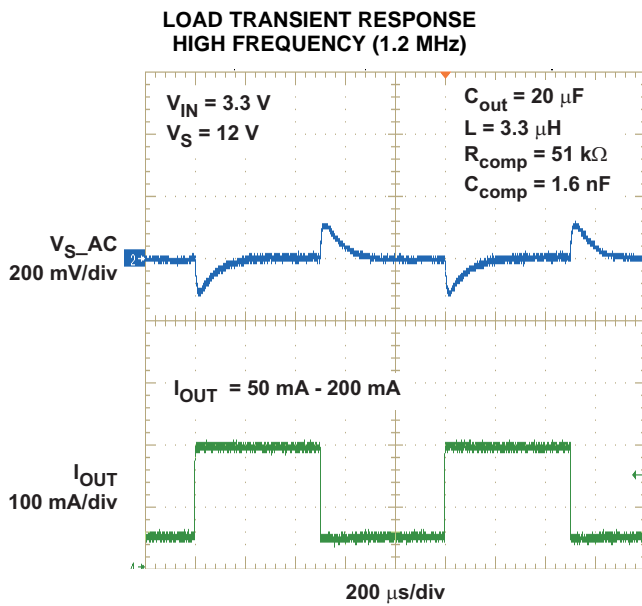

Figure 5.

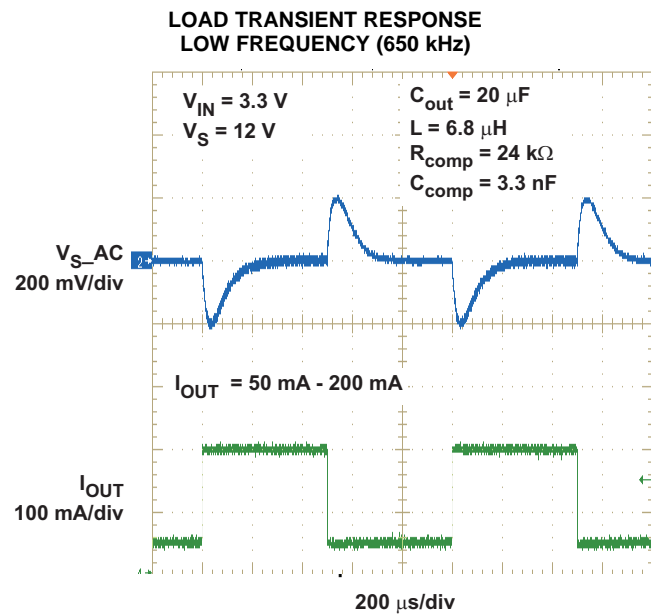

Figure 6.

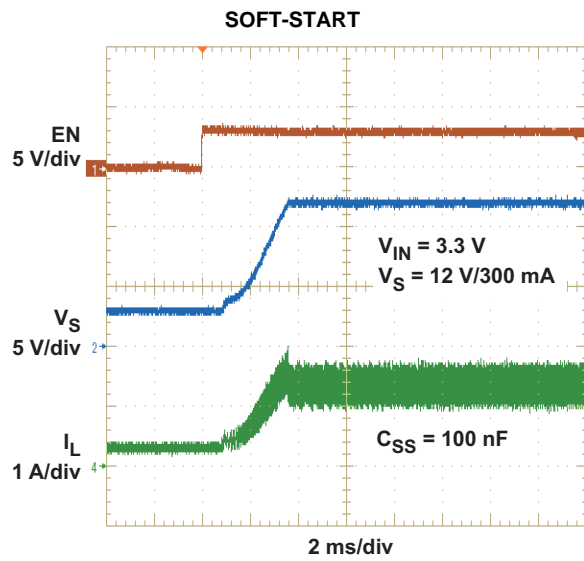

Figure 7.

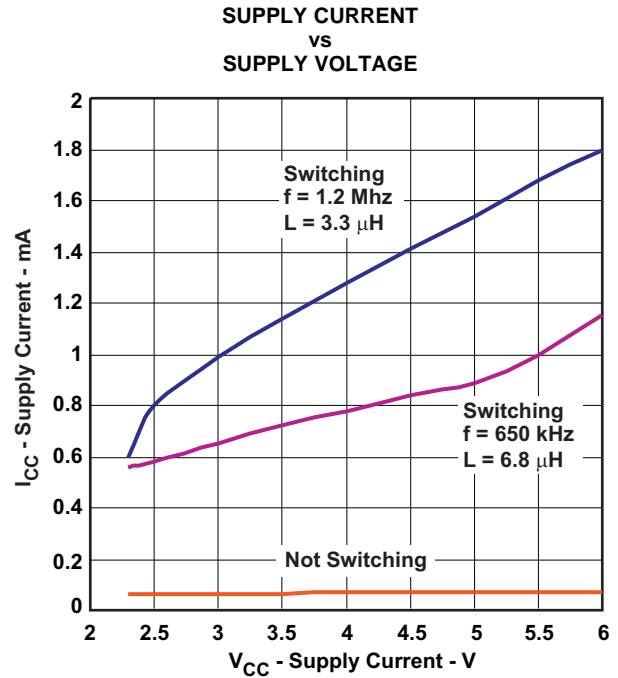

Figure 8.

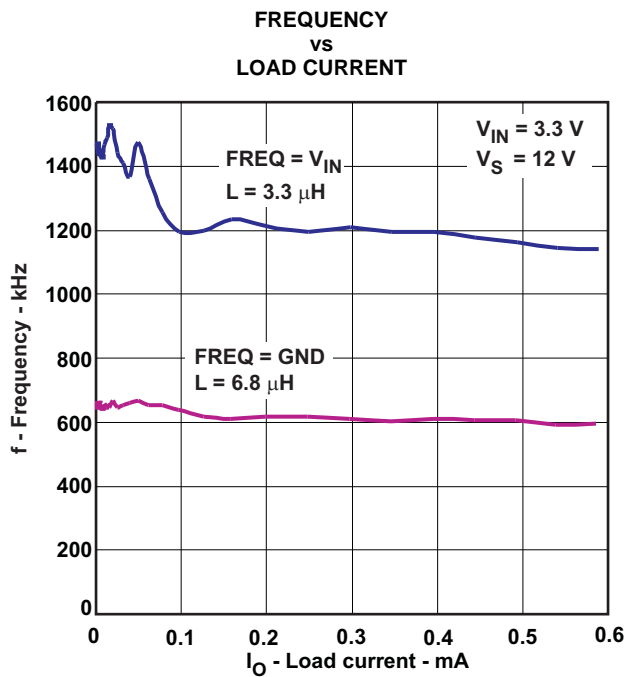

Figure 9.

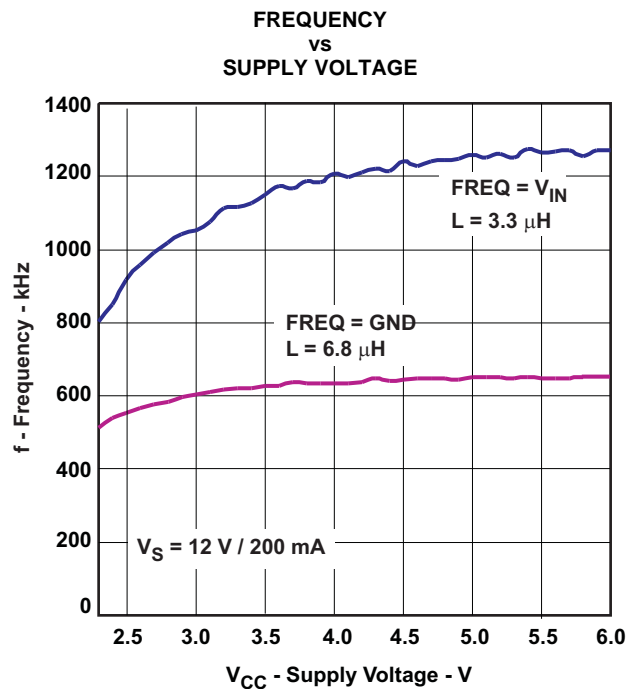

Figure 10.

DETAILED DESCRIPTION

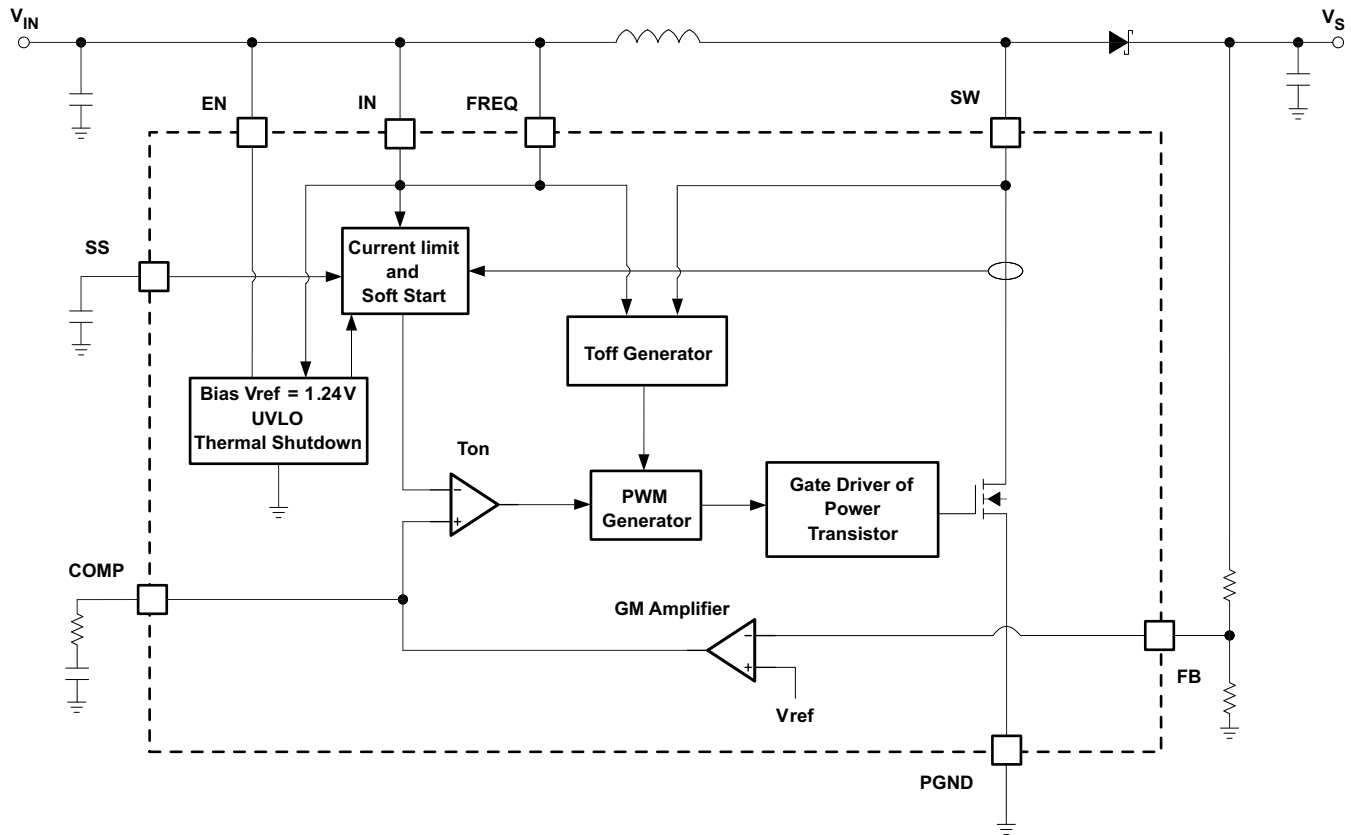

Figure 11. Block Diagram

The boost converter is designed for output voltages up to 18.5 V with a switch peak current limit of 2.0 A minimum. The device, which operates in a current mode scheme with quasi-constant frequency, is externally compensated for maximum flexibility and stability. The switching frequency is selectable between 650 kHz and 1.2 MHz and the minimum input voltage is 2.3 V. To control the inrush current at start-up a soft-start pin is available.

During the on-time, the voltage across the inductor causes the current in it to rise. When the current reaches a threshold value set by the internal GM amplifier, the power transistor is turned off, the energy stored into the inductor is then released and the current flows through the Schottky diode towards the output of the boost converter. The off-time is fixed for a certain V_{IN} and V_S , and therefore maintains the same frequency when varying these parameters.

However, for different output loads, the frequency may slightly change due to the voltage drop across the $R_{ds(on)}$ of the power transistor which will have an effect on the voltage across the inductor and thus on t_{ON} (t_{OFF} remains fixed). Some slight frequency changes might also appear with a fixed output load due to the fact that the output voltage V_S is not sensed directly but via the SW Pin, which affects accuracy.

Because of the quasi-constant frequency behavior of the device, the TPS61085 eliminates the need for an internal oscillator and slope compensation, which provides better stability for the system over a wide of input and output voltages range, and more stable and accurate current limiting operation compared to boost converters operating with a conventional PWM scheme. The TPS61085 topology has also the benefits of providing very good load and line regulations, and excellent load transient response.

Design Procedure

The first step in the design procedure is to verify that the maximum possible output current of the boost converter supports the specific application requirements. A simple approach is to estimate the converter efficiency, by taking the efficiency numbers from the provided efficiency curves or to use a worst case assumption for the expected efficiency, e.g. 90%.

$$D = 1 - \frac{V_{IN} \times \eta}{V_S}$$

1. Duty Cycle:

$$I_{out} = \left(I_{swpeak} - \frac{\Delta I_L}{2} \right) \times (1 - D)$$

2. Maximum output current:

$$I_{swpeak} = \frac{\Delta I_L}{2} + \frac{I_{out}}{1 - D}$$

3. Peak switch current:

$$\Delta I_L = \frac{V_{IN} \times D}{f_s \times L}$$

with

and

I_{swpeak} = converter switch current (minimum switch current limit = 2.0 A)

f_s = Converter switching frequency (typically 1.2 MHz)

L = Selected inductor value

η = Estimated converter efficiency (please use the number from the efficiency plots or 90% as an estimation)

ΔI_L = Inductor peak-to-peak ripple current

The peak switch current is the steady state peak switch current that the integrated switch, inductor and external Schottky diode has to be able to handle. The calculation must be done for the minimum input voltage where the peak switch current is the highest.

Soft-start

The boost converter has an adjustable soft-start to prevent high inrush current during start-up. To minimize the inrush current during start-up an external capacitor connected to the soft-start pin SS is used to slowly ramp up the internal current limit of the boost converter when charged with a constant current. When the EN pin is pulled high, the soft-start capacitor C_{SS} is immediately charged to 0.3 V. The capacitor is then charged at a constant current of 10 μ A typically until the output of the boost converter V_S has reached its Power Good threshold (90% of V_S nominal value). During this time, the SS voltage directly controls the peak inductor current, starting with 0 A at $V_{SS} = 0.3$ V up to the full current limit at $V_{SS} \approx 800$ mV. The maximum load current is available after the soft-start is completed. The larger the capacitor the slower the ramp of the current limit and the longer the soft-start time. A 100 nF capacitor is usually sufficient for most of the applications. When the EN pin is pulled low, the soft-start capacitor is discharged to ground.

Inductor Selection

The TPS61085 is designed to work with a wide range of inductors. The main parameter for the inductor selection is the saturation current of the inductor which should be higher than the peak switch current as calculated in the *Design Procedure* section with additional margin to cover for heavy load transients. An alternative, more conservative, is to choose an inductor with a saturation current at least as high as the maximum switch current limit of 3.2 A. The other important parameter is the inductor dc resistance. Usually, the lower the dc resistance the higher the efficiency. It is important to note that the inductor dc resistance is not the only parameter determining the efficiency. Especially for a boost converter where the inductor is the energy storage element, the type and core material of the inductor influences the efficiency as well. At high switching frequencies of 1.2 MHz inductor core losses, proximity effects and skin effects become more important. Usually, an inductor with a larger form factor gives higher efficiency. The efficiency difference between different inductors can vary between 2% to 10%. For the TPS61085, inductor values between 3 μ H and 6 μ H are a good choice with a switching frequency of 1.2 MHz, typically 3.3 μ H. At 650 kHz we recommend inductors between 6 μ H and 13 μ H, typically 6.8 μ H. Possible inductors are shown in [Table 1](#).

Typically, it is recommended that the inductor current ripple is below 20% of the average inductor current. The following equation can therefore be used to calculate the inductor value:

$$L = \left(\frac{V_{IN}}{V_S} \right)^2 \times \left(\frac{V_S - V_{IN}}{I_{out_max} \times f} \right) \times \left(\frac{\eta}{0.35} \right) \quad (1)$$

Table 1. Inductor Selection

L (μH)	SUPPLIER	COMPONENT CODE	SIZE (L×W×H mm)	DCR TYP (mΩ)	Isat (A)
1.2 MHz					
3.3	Sumida	CDH38D09	4 × 4 × 1	240	1.25
4.7	Sumida	CDPH36D13	5 × 5 × 1.5	155	1.36
3.3	Sumida	CDPH4D19F	5.2 × 5.2 × 2	33	1.5
3.3	Sumida	CDRH6D12	6.7 × 6.7 × 1.5	62	2.2
4.7	WÄ¼rth Elektronik	7447785004	5.9 × 6.2 × 3.3	60	2.5
5	Coilcraft	MSS7341	7.3 × 7.3 × 4.1	24	2.9
650 kHz					
6.8	Sumida	CDP14D19	5.2 × 5.2 × 2	50	1
10	Coilcraft	LPS4414	4.3 × 4.3 × 1.4	380	1.2
6.8	Sumida	CDRH6D12/LD	6.7 × 6.7 × 1.5	95	1.25
10	Sumida	CDR6D23	5 × 5 × 2.4	133	1.75
10	WÄ¼rth Elektronik	744778910	7.3 × 7.3 × 3.2	51	2.2
6.8	Sumida	CDRH6D26HP	7 × 7 × 2.8	52	2.9

Rectifier Diode Selection

To achieve high efficiency, a Schottky type should be used for the rectifier diode. The reverse voltage rating should be higher than the maximum output voltage of the converter. The averaged rectified forward current I_{avg} , the Schottky diode needs to be rated for, is equal to the output current I_{out} :

$$I_{avg} = I_{out} \quad (2)$$

Usually a Schottky diode with 2 A maximum average rectified forward current rating is sufficient for most applications. The Schottky rectifier can be selected with lower forward current capability depending on the output current I_{out} but has to be able to dissipate the power. The dissipated power is the average rectified forward current times the diode forward voltage.

$$P_D = I_{avg} \times V_{forward}$$

Typically the diode should be able to dissipate around 500mW depending on the load current and forward voltage.

Table 2. Rectifier Diode Selection

CURRENT RATING I_{avg}	Vr	V _{forward} / I_{avg}	SUPPLIER	COMPONENT CODE	PACKAGE TYPE
750 mA	20 V	0.425 V / 750 mA	Fairchild Semiconductor	FYV0704S	SOT 23
1 A	20 V	0.39 V / 1 A	NXP	PMEG2010AEH	SOD 123
1 A	20 V	0.52 V / 1 A	Vishay Semiconductor	B120	SMA
1 A	20 V	0.5 V / 1 A	Vishay Semiconductor	SS12	SMA
1 A	20 V	0.44 V / 1 A	Vishay Semiconductor	MSS1P2L	μ-SMP (Low Profile)

Setting the Output Voltage

The output voltage is set by an external resistor divider. Typically, a minimum current of 50 μ A flowing through the feedback divider gives good accuracy and noise covering. A standard low side resistor of 18 k Ω is typically selected. The resistors are then calculated as:

$$R2 = \frac{V_{ref}}{70\mu A} \approx 18k\Omega \quad R1 = R2 \times \left(\frac{V_s}{V_{ref}} - 1 \right) \quad (3)$$

Compensation (COMP)

The regulator loop can be compensated by adjusting the external components connected to the COMP pin. The COMP pin is the output of the internal transconductance error amplifier. Standard values of $R_{COMP} = 13$ k Ω and $C_{COMP} = 3.3$ nF will work for the majority of the applications.

Please refer to [Table 3](#) for dedicated compensation networks giving an improved load transient response. The following equations can be used to calculate R_{COMP} and C_{COMP} :

$$R_{COMP} = \frac{125 \times V_{IN} \times V_s \times C_{out}}{L \times I_{out_max}} \quad C_{COMP} = \frac{V_s \times C_{out}}{5 \times I_{out_max} \times R_{COMP}} \quad (4)$$

Table 3. Recommended Compensation Network Values at High/Low Frequency

FREQUENCY	L	V _s	V _{IN} \pm 20%	R _{COMP}	C _{COMP}
High (1.2 MHz)	3.3 μ H	15 V	5 V	82 k Ω	1.1 nF
			3.3 V	75 k Ω	1.6 nF
		12 V	5 V	51 k Ω	1.1 nF
			3.3 V	47 k Ω	1.6 nF
		9 V	5 V	30 k Ω	1.1 nF
			3.3 V	27 k Ω	1.6 nF
Low (650 kHz)	6.8 μ H	15 V	5 V	43 k Ω	2.2 nF
			3.3 V	39 k Ω	3.3 nF
		12 V	5 V	27 k Ω	2.2 nF
			3.3 V	24 k Ω	3.3 nF
		9 V	5 V	15 k Ω	2.2 nF
			3.3 V	13 k Ω	3.3 nF

[Table 3](#) gives conservatives Rcomp and Comp values for certain inductors, input and output voltages providing a very stable system. For a faster response time, a higher Rcomp value can be used to enlarge the bandwidth, as well as a slightly lower value of Ccomp to keep enough phase margin. These adjustments should be performed in parallel with the load transient response monitoring of TPS61085.

Input Capacitor Selection

For good input voltage filtering low ESR ceramic capacitors are recommended. TPS61085 has an analog input IN. Therefore, a 1 μ F bypass is highly recommended as close as possible to the IC from IN to GND.

One 10 μ F ceramic input capacitors are sufficient for most of the applications. For better input voltage filtering this value can be increased. Refer to [Table 4](#) and typical applications for input capacitor recommendations.

Output Capacitor Selection

For best output voltage filtering a low ESR output capacitor like ceramic capacitor is recommended. Two 10 μ F ceramic output capacitors (or one 22 μ F) work for most of the applications. Higher capacitor values can be used to improve the load transient response. Refer to [Table 4](#) for the selection of the output capacitor.

Table 4. Rectifier Input and Output Capacitor Selection

	CAPACITOR	VOLTAGE RATING	SUPPLIER	COMPONENT CODE
C _{IN}	10 μ F/1206	16 V	Taiyo Yuden	EMK212 BJ 106KG
IN bypass	1 μ F/0603	16 V	Taiyo Yuden	EMK107 BJ 105KA
C _{OUT}	10 μ F/1206	25 V	Taiyo Yuden	TMK316 BJ 106KL

Frequency Select Pin (FREQ)

The frequency select pin FREQ allows to set the switching frequency of the device to 650 kHz (FREQ = low) or 1.2 MHz (FREQ = high). Higher switching frequency improves load transient response but reduces slightly the efficiency. The other benefits of higher switching frequency are a lower output ripple voltage. Usually, it is recommended to use 1.2 MHz switching frequency unless light load efficiency is a major concern.

Undervoltage Lockout (UVLO)

To avoid mis-operation of the device at low input voltages an undervoltage lockout is included that disables the device, if the input voltage falls below 2.2 V.

Thermal Shutdown

A thermal shutdown is implemented to prevent damages due to excessive heat and power dissipation. Typically the thermal shutdown threshold is 150°C. When the thermal shutdown is triggered the device stops switching until the temperature falls below typically 136°C. Then the device starts switching again.

APPLICATION INFORMATION

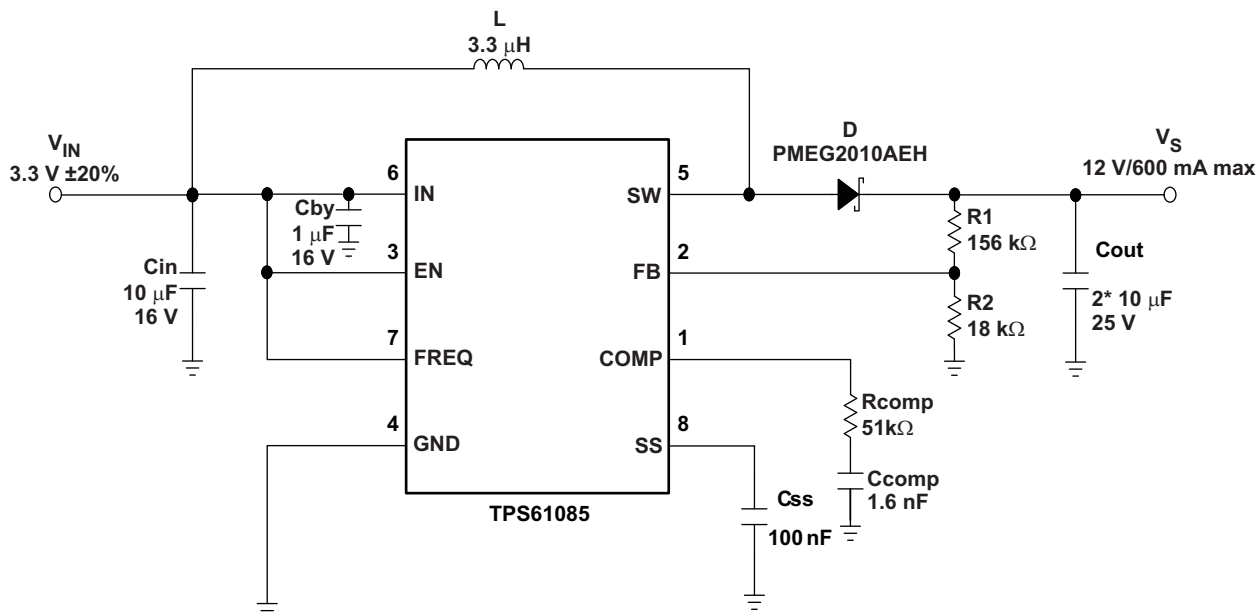

Figure 12. Typical Application, 3.3 V to 12 V ($f_{sw} = 1.2$ MHz)

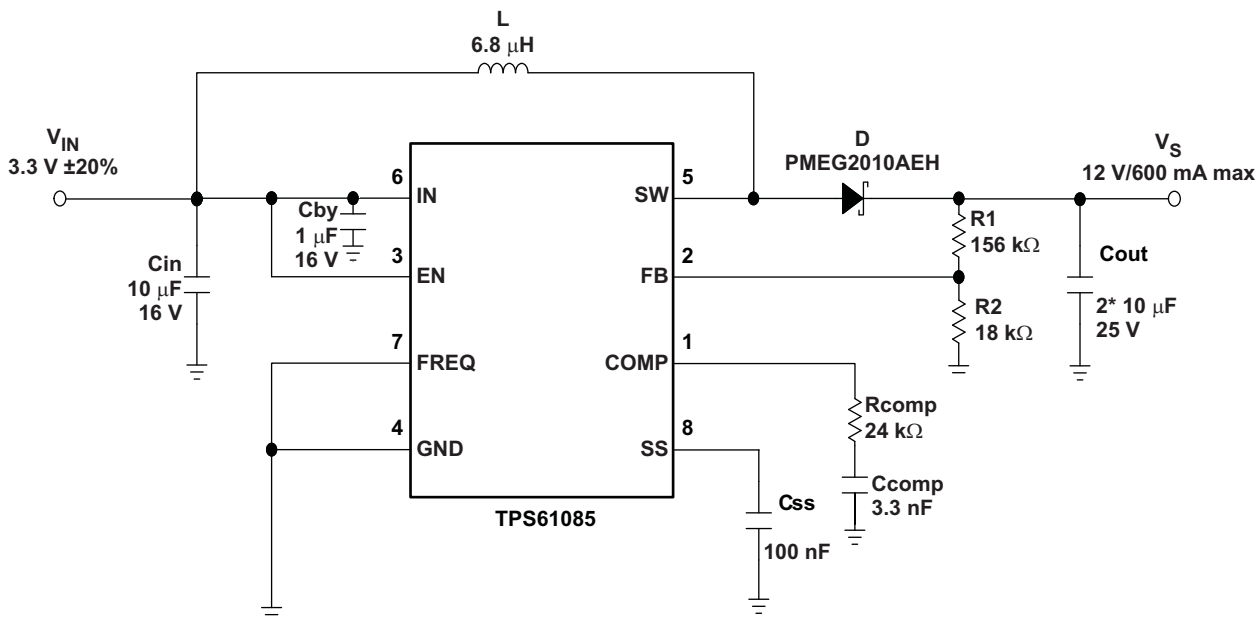

Figure 13. Typical Application, 3.3 V to 12 V ($f_{sw} = 650$ kHz)

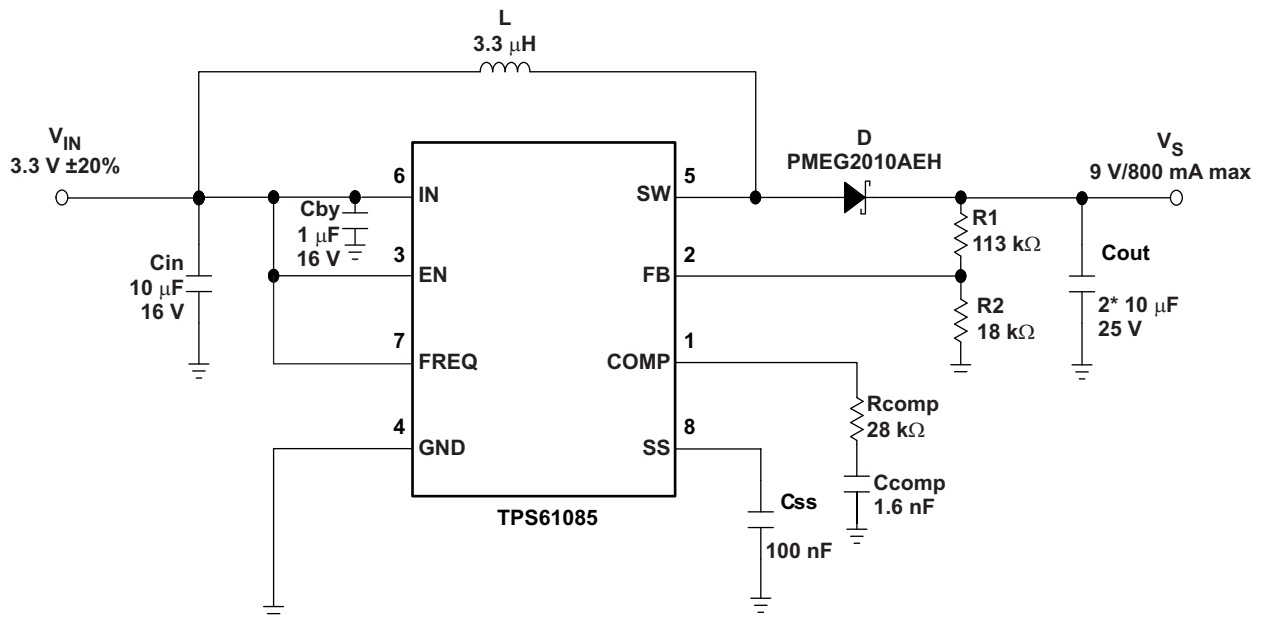

Figure 14. Typical Application, 3.3 V to 9 V ($f_{sw} = 1.2\ \text{MHz}$)

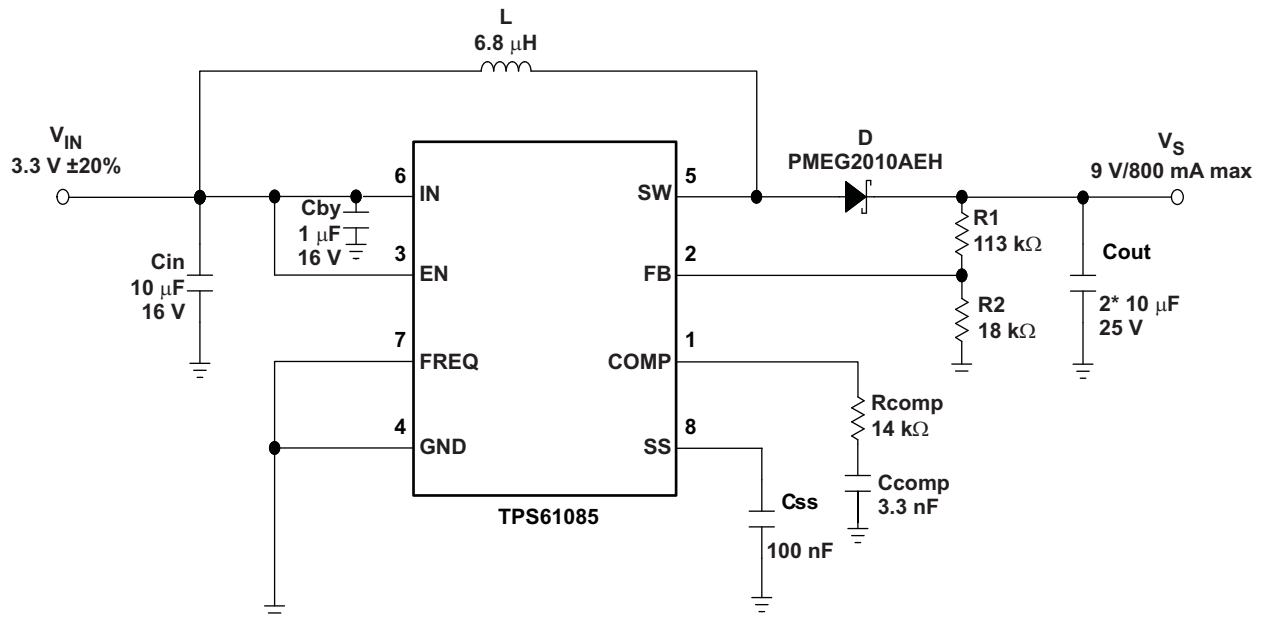

Figure 15. Typical Application, 3.3 V to 9 V ($f_{sw} = 650\ \text{kHz}$)

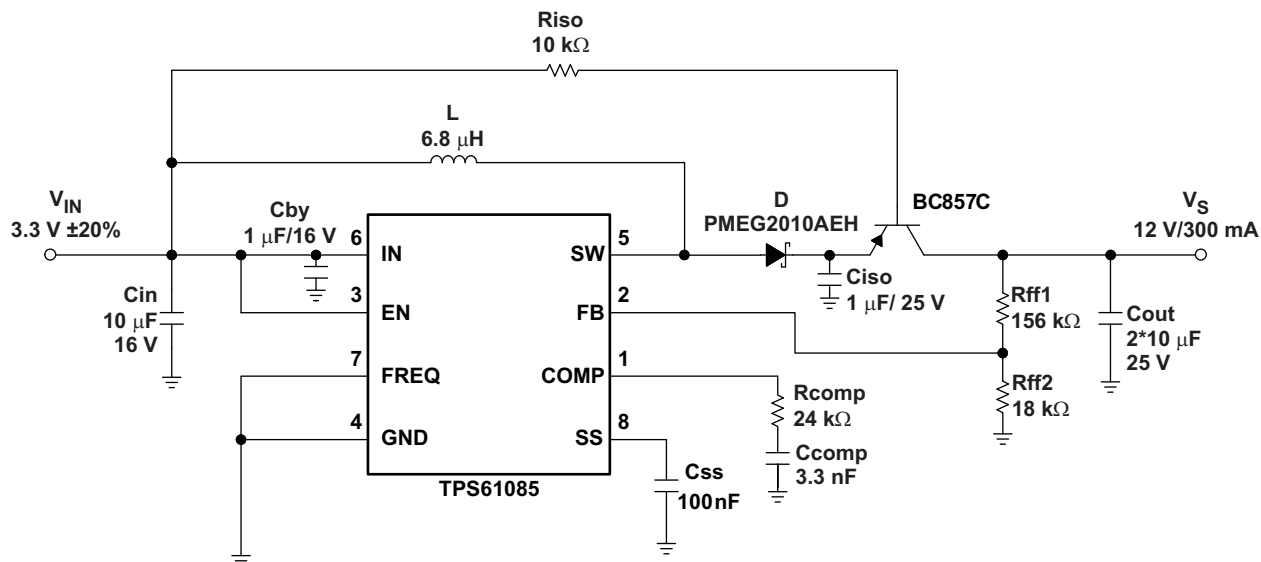

Figure 16. Typical Application with External Load Disconnect Switch

TFT LCD APPLICATION

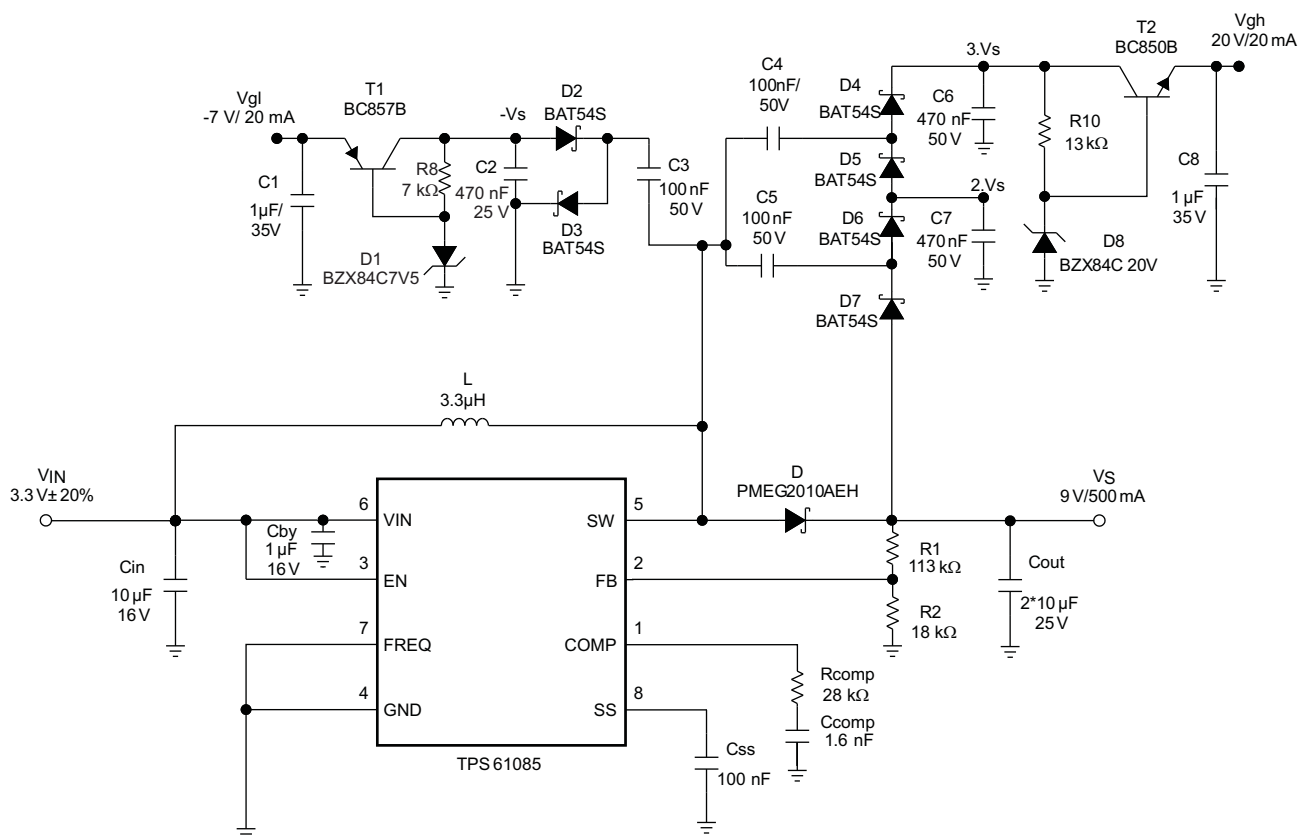

Figure 17. Typical Application 3.3 V to 9 V ($f_{sw} = 1.2$ MHz) for TFT LCD with External Charge Pumps (VGH, VGL)

WHITE LED APPLICATIONS

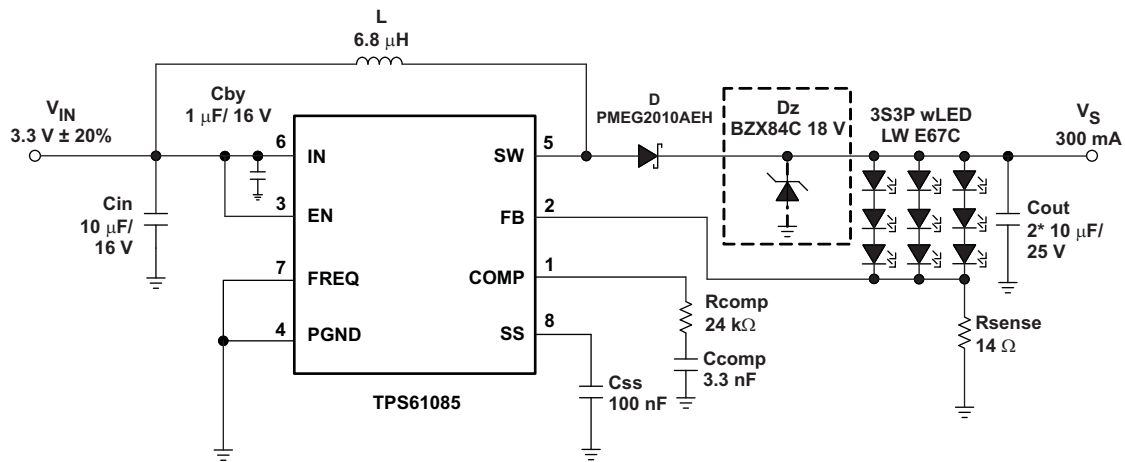

Figure 18. Simple Application (3.3V input - $f_{sw} = 650\ \text{kHz}$) for wLED Supply (3S3P) (with optional clamping Zener diode)

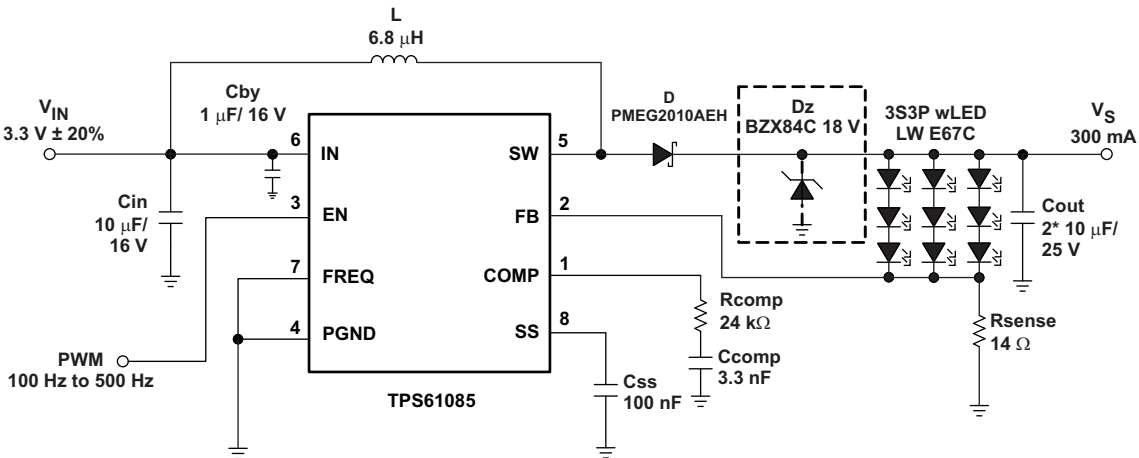

Figure 19. Simple Application (3.3V input - $f_{sw} = 650\ \text{kHz}$) for wLED Supply (3S3P) with Adjustable Brightness Control using a PWM Signal on the Enable Pin (with optional clamping Zener diode)

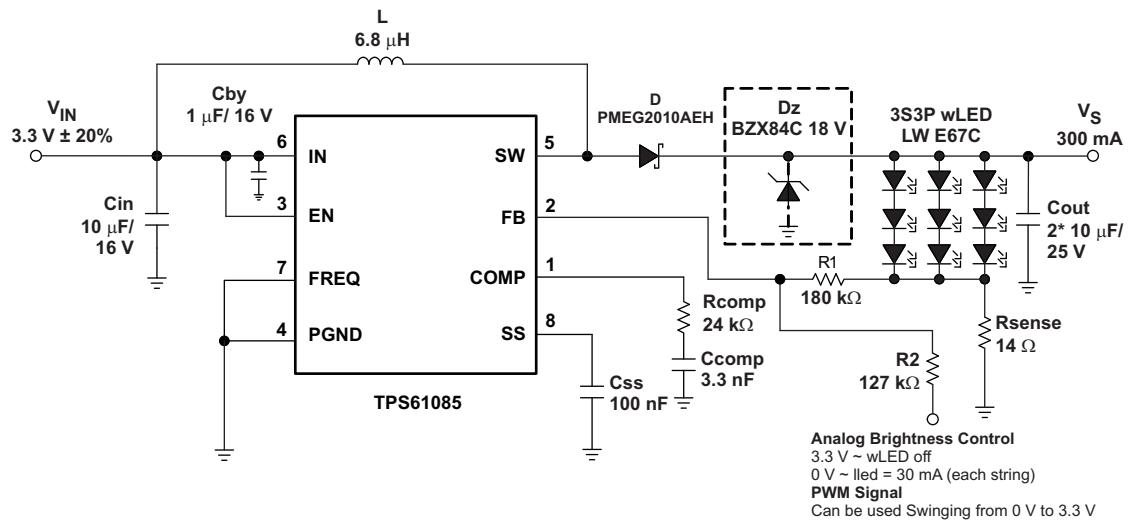

Figure 20. Simple Application (3.3V input - $f_{sw} = 650$ kHz) for wLED Supply (3S3P) with Adjustable Brightness Control using an Analog Signal on the Feedback Pin (with optional clamping Zener diode)

PACKAGING INFORMATION

Orderable Device	Status (1)	Package Type	Package Drawing	Pins	Package Qty	Eco Plan (2)	Lead/Ball Finish	MSL Peak Temp (3)	Op Temp (°C)	Top-Side Markings (4)	Samples
TPS61085TDGKR	ACTIVE	VSSOP	DGK	8	2000	Green (RoHS & no Sb/Br)	CU NIPDAU	Level-1-260C-UNLIM	-40 to 105	PTQI	Samples
TPS61085TPWR	ACTIVE	TSSOP	PW	8	2000	Green (RoHS & no Sb/Br)	CU NIPDAU	Level-1-260C-UNLIM	-40 to 105	61085T	Samples

(1) The marketing status values are defined as follows:

ACTIVE: Product device recommended for new designs.

LIFEBUY: TI has announced that the device will be discontinued, and a lifetime-buy period is in effect.

NRND: Not recommended for new designs. Device is in production to support existing customers, but TI does not recommend using this part in a new design.

PREVIEW: Device has been announced but is not in production. Samples may or may not be available.

OBSOLETE: TI has discontinued the production of the device.

(2) Eco Plan - The planned eco-friendly classification: Pb-Free (RoHS), Pb-Free (RoHS Exempt), or Green (RoHS & no Sb/Br) - please check <http://www.ti.com/productcontent> for the latest availability information and additional product content details.

TBD: The Pb-Free/Green conversion plan has not been defined.

Pb-Free (RoHS): TI's terms "Lead-Free" or "Pb-Free" mean semiconductor products that are compatible with the current RoHS requirements for all 6 substances, including the requirement that lead not exceed 0.1% by weight in homogeneous materials. Where designed to be soldered at high temperatures, TI Pb-Free products are suitable for use in specified lead-free processes.

Pb-Free (RoHS Exempt): This component has a RoHS exemption for either 1) lead-based flip-chip solder bumps used between the die and package, or 2) lead-based die adhesive used between the die and leadframe. The component is otherwise considered Pb-Free (RoHS compatible) as defined above.

Green (RoHS & no Sb/Br): TI defines "Green" to mean Pb-Free (RoHS compatible), and free of Bromine (Br) and Antimony (Sb) based flame retardants (Br or Sb do not exceed 0.1% by weight in homogeneous material)

(3) MSL, Peak Temp. -- The Moisture Sensitivity Level rating according to the JEDEC industry standard classifications, and peak solder temperature.

(4) Multiple Top-Side Markings will be inside parentheses. Only one Top-Side Marking contained in parentheses and separated by a "~" will appear on a device. If a line is indented then it is a continuation of the previous line and the two combined represent the entire Top-Side Marking for that device.

Important Information and Disclaimer: The information provided on this page represents TI's knowledge and belief as of the date that it is provided. TI bases its knowledge and belief on information provided by third parties, and makes no representation or warranty as to the accuracy of such information. Efforts are underway to better integrate information from third parties. TI has taken and continues to take reasonable steps to provide representative and accurate information but may not have conducted destructive testing or chemical analysis on incoming materials and chemicals. TI and TI suppliers consider certain information to be proprietary, and thus CAS numbers and other limited information may not be available for release.

In no event shall TI's liability arising out of such information exceed the total purchase price of the TI part(s) at issue in this document sold by TI to Customer on an annual basis.

TAPE AND REEL INFORMATION

REEL DIMENSIONS

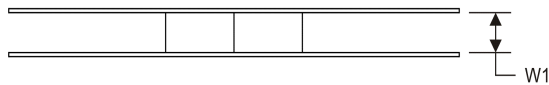
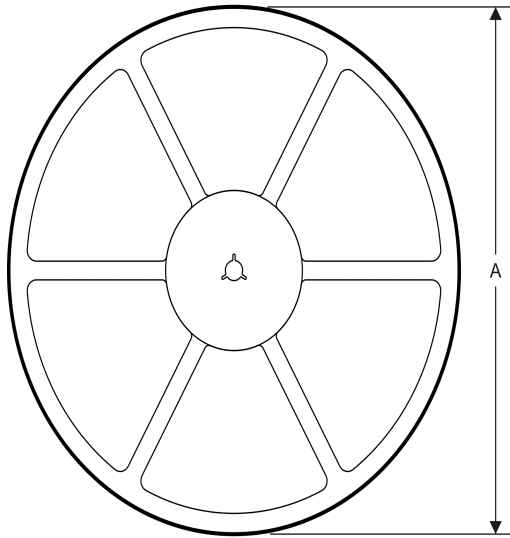

TAPE DIMENSIONS

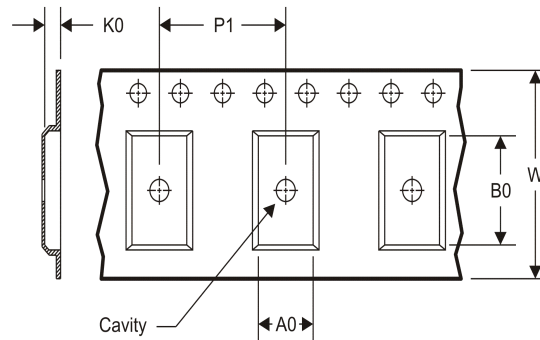

A0	Dimension designed to accommodate the component width
B0	Dimension designed to accommodate the component length
K0	Dimension designed to accommodate the component thickness
W	Overall width of the carrier tape
P1	Pitch between successive cavity centers

TAPE AND REEL INFORMATION

*All dimensions are nominal

Device	Package Type	Package Drawing	Pins	SPQ	Reel Diameter (mm)	Reel Width W1 (mm)	A0 (mm)	B0 (mm)	K0 (mm)	P1 (mm)	W (mm)	Pin1 Quadrant
TPS61085TDGKR	VSSOP	DGK	8	2000	330.0	12.4	5.3	3.4	1.4	8.0	12.0	Q1
TPS61085TPWR	TSSOP	PW	8	2000	330.0	12.4	7.0	3.6	1.6	8.0	12.0	Q1

TAPE AND REEL BOX DIMENSIONS

*All dimensions are nominal

Device	Package Type	Package Drawing	Pins	SPQ	Length (mm)	Width (mm)	Height (mm)
TPS61085TDGKR	VSSOP	DGK	8	2000	367.0	367.0	35.0
TPS61085TPWR	TSSOP	PW	8	2000	367.0	367.0	35.0

DGK (S-PDSO-G8)

PLASTIC SMALL-OUTLINE PACKAGE

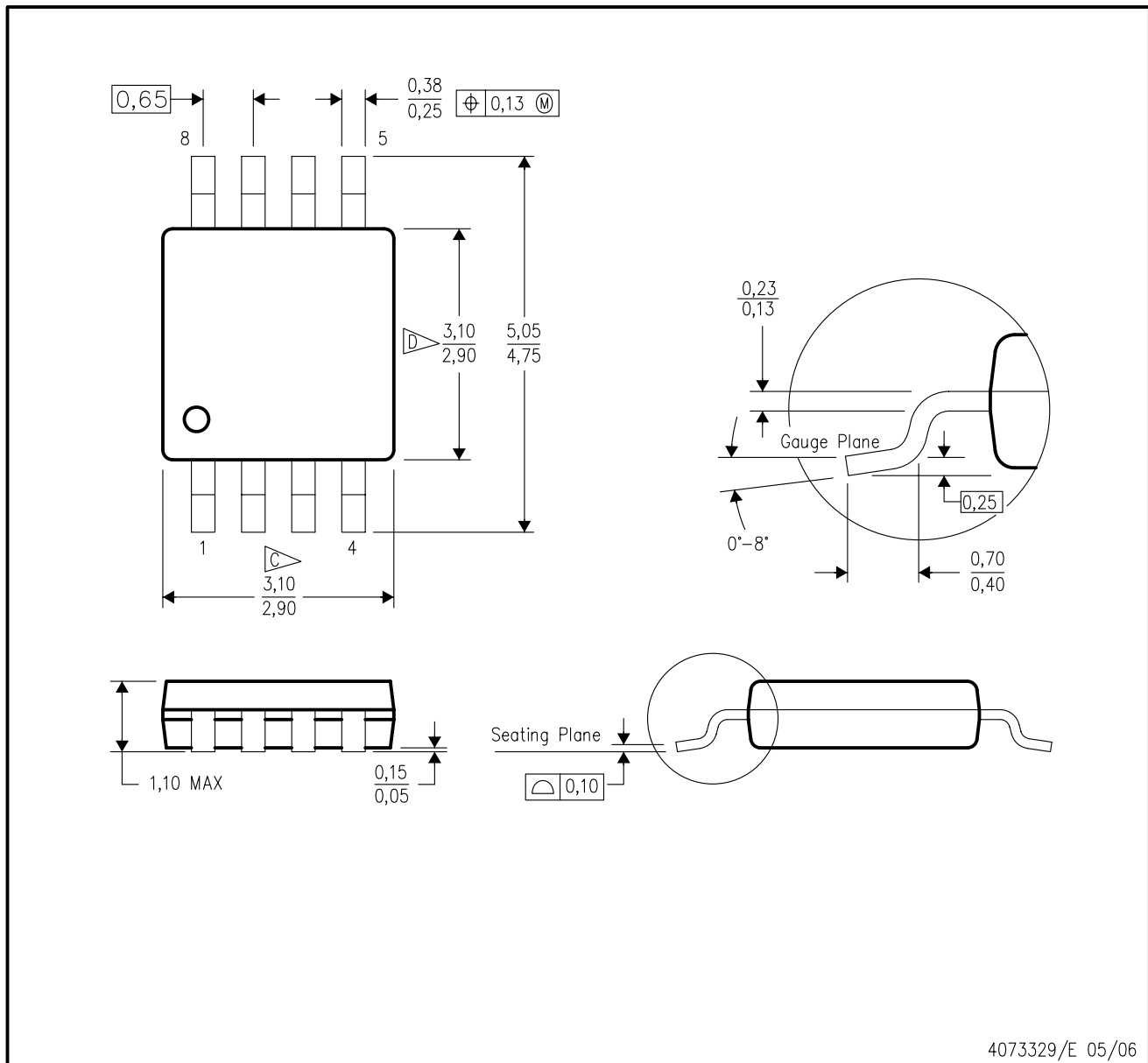

- NOTES:
- A. All linear dimensions are in millimeters.
 - B. This drawing is subject to change without notice.
 - C. Body length does not include mold flash, protrusions, or gate burrs. Mold flash, protrusions, or gate burrs shall not exceed 0.15 per end.
 - D. Body width does not include interlead flash. Interlead flash shall not exceed 0.50 per side.
 - E. Falls within JEDEC MO-187 variation AA, except interlead flash.



- NOTES:
- A. All linear dimensions are in millimeters.
 - B. This drawing is subject to change without notice.
 - C. Publication IPC-7351 is recommended for alternate designs.
 - D. Laser cutting apertures with trapezoidal walls and also rounding corners will offer better paste release. Customers should contact their board assembly site for stencil design recommendations. Refer to IPC-7525 for other stencil recommendations.
 - E. Customers should contact their board fabrication site for solder mask tolerances between and around signal pads.

PW0008A



PACKAGE OUTLINE

TSSOP - 1.2 mm max height

SMALL OUTLINE PACKAGE



4221848/A 02/2015

NOTES:

1. All linear dimensions are in millimeters. Any dimensions in parenthesis are for reference only. Dimensioning and tolerancing per ASME Y14.5M.
2. This drawing is subject to change without notice.
3. This dimension does not include mold flash, protrusions, or gate burrs. Mold flash, protrusions, or gate burrs shall not exceed 0.15 mm per side.
4. This dimension does not include interlead flash. Interlead flash shall not exceed 0.25 mm per side.
5. Reference JEDEC registration MO-153, variation AA.

EXAMPLE BOARD LAYOUT

PW0008A

TSSOP - 1.2 mm max height

SMALL OUTLINE PACKAGE



LAND PATTERN EXAMPLE
SCALE:10X



SOLDER MASK DETAILS
NOT TO SCALE

4221848/A 02/2015

NOTES: (continued)

- 6. Publication IPC-7351 may have alternate designs.
- 7. Solder mask tolerances between and around signal pads can vary based on board fabrication site.

EXAMPLE STENCIL DESIGN

PW0008A

TSSOP - 1.2 mm max height

SMALL OUTLINE PACKAGE



SOLDER PASTE EXAMPLE
BASED ON 0.125 mm THICK STENCIL
SCALE:10X

4221848/A 02/2015

NOTES: (continued)

8. Laser cutting apertures with trapezoidal walls and rounded corners may offer better paste release. IPC-7525 may have alternate design recommendations.
9. Board assembly site may have different recommendations for stencil design.

IMPORTANT NOTICE

Texas Instruments Incorporated and its subsidiaries (TI) reserve the right to make corrections, enhancements, improvements and other changes to its semiconductor products and services per JESD46, latest issue, and to discontinue any product or service per JESD48, latest issue. Buyers should obtain the latest relevant information before placing orders and should verify that such information is current and complete. All semiconductor products (also referred to herein as "components") are sold subject to TI's terms and conditions of sale supplied at the time of order acknowledgment.

TI warrants performance of its components to the specifications applicable at the time of sale, in accordance with the warranty in TI's terms and conditions of sale of semiconductor products. Testing and other quality control techniques are used to the extent TI deems necessary to support this warranty. Except where mandated by applicable law, testing of all parameters of each component is not necessarily performed.

TI assumes no liability for applications assistance or the design of Buyers' products. Buyers are responsible for their products and applications using TI components. To minimize the risks associated with Buyers' products and applications, Buyers should provide adequate design and operating safeguards.

TI does not warrant or represent that any license, either express or implied, is granted under any patent right, copyright, mask work right, or other intellectual property right relating to any combination, machine, or process in which TI components or services are used. Information published by TI regarding third-party products or services does not constitute a license to use such products or services or a warranty or endorsement thereof. Use of such information may require a license from a third party under the patents or other intellectual property of the third party, or a license from TI under the patents or other intellectual property of TI.

Reproduction of significant portions of TI information in TI data books or data sheets is permissible only if reproduction is without alteration and is accompanied by all associated warranties, conditions, limitations, and notices. TI is not responsible or liable for such altered documentation. Information of third parties may be subject to additional restrictions.

Resale of TI components or services with statements different from or beyond the parameters stated by TI for that component or service voids all express and any implied warranties for the associated TI component or service and is an unfair and deceptive business practice. TI is not responsible or liable for any such statements.

Buyer acknowledges and agrees that it is solely responsible for compliance with all legal, regulatory and safety-related requirements concerning its products, and any use of TI components in its applications, notwithstanding any applications-related information or support that may be provided by TI. Buyer represents and agrees that it has all the necessary expertise to create and implement safeguards which anticipate dangerous consequences of failures, monitor failures and their consequences, lessen the likelihood of failures that might cause harm and take appropriate remedial actions. Buyer will fully indemnify TI and its representatives against any damages arising out of the use of any TI components in safety-critical applications.

In some cases, TI components may be promoted specifically to facilitate safety-related applications. With such components, TI's goal is to help enable customers to design and create their own end-product solutions that meet applicable functional safety standards and requirements. Nonetheless, such components are subject to these terms.

No TI components are authorized for use in FDA Class III (or similar life-critical medical equipment) unless authorized officers of the parties have executed a special agreement specifically governing such use.

Only those TI components which TI has specifically designated as military grade or "enhanced plastic" are designed and intended for use in military/aerospace applications or environments. Buyer acknowledges and agrees that any military or aerospace use of TI components which have **not** been so designated is solely at the Buyer's risk, and that Buyer is solely responsible for compliance with all legal and regulatory requirements in connection with such use.

TI has specifically designated certain components as meeting ISO/TS16949 requirements, mainly for automotive use. In any case of use of non-designated products, TI will not be responsible for any failure to meet ISO/TS16949.

Products

Audio	www.ti.com/audio
Amplifiers	amplifier.ti.com
Data Converters	dataconverter.ti.com
DLP® Products	www.dlp.com
DSP	dsp.ti.com
Clocks and Timers	www.ti.com/clocks
Interface	interface.ti.com
Logic	logic.ti.com
Power Mgmt	power.ti.com
Microcontrollers	microcontroller.ti.com
RFID	www.ti-rfid.com
OMAP Applications Processors	www.ti.com/omap
Wireless Connectivity	www.ti.com/wirelessconnectivity

Applications

Automotive and Transportation	www.ti.com/automotive
Communications and Telecom	www.ti.com/communications
Computers and Peripherals	www.ti.com/computers
Consumer Electronics	www.ti.com/consumer-apps
Energy and Lighting	www.ti.com/energy
Industrial	www.ti.com/industrial
Medical	www.ti.com/medical
Security	www.ti.com/security
Space, Avionics and Defense	www.ti.com/space-avionics-defense
Video and Imaging	www.ti.com/video

TI E2E Community

e2e.ti.com