

TPS61196 6-String 400-mA WLED Driver with Independent PWM Dimming for Each String

1 Features

- 8-V to 30-V Input Voltage
- Up to 120-V Output Voltage
- 100-KHz to 800-kHz Programmable Switching Frequency
- Adaptive Boost Output for LED Voltages
- Six Current Sinks, 200-mA Continuous Output, 400-mA Pulse Output for Each String
- $\pm 1.5\%$ Current Matching Between Strings
- High Precision PWM Dimming Resolution up to 5000:1
- Programmable Overvoltage Threshold at Output and Each Current Sink
- Programmable Undervoltage Threshold at Input with Adjustable Hysteresis
- Adjustable Soft Start Time Independent of Dimming Duty Cycle
- Built-in LED Open and LED Short Protection
- Built-in Schottky Diode Open/Short Protection
- Built-in ISET Short Protection
- Built-in IFB Short Protection
- Thermal Shutdown

2 Applications

- LCD TV Backlight
- Scan Mode LCD TV Backlight

3 Description

The TPS61196 provides a highly integrated solution for LCD TV backlight with an independent PWM dimming function for each string. This device is a current mode boost controller driving up to six WLED strings with multiple LEDs in series. Each string has an independent current regulator providing a LED current adjustable from 50 mA to 400 mA within $\pm 1.5\%$ matching accuracy. The minimal voltage at the current sink is programmable in the range of 0.3 V to 1 V to fit with different LED current settings. The input voltage range for the device is from 8 V to 30 V.

The device adjusts the boost controller's output voltage automatically to provide only the voltage required by the LED string with the largest forward voltage drop plus the minimum required voltage at that string's IFB pin, thereby optimizing driver efficiency. Its switching frequency is programmed by an external resistor from 100 kHz to 800 kHz.

The TPS61196 supports direct PWM brightness dimming. Each string has an independent PWM control input. During the PWM dimming, the LED current is turned on or turned off at the frequency and duty cycle which are determined by the external PWM signal. The PWM frequency ranges from 90 Hz to 22 kHz.

The device integrates overcurrent protection, output short-circuit protection, ISET short-to-ground protection, diode open and short protection, LED open and short protection, and overtemperature shutdown circuit. In addition, the TPS61196 can detect the IFB pin short to ground to protect the LED string. The device also provides programmable input undervoltage lockout threshold and output overvoltage protection threshold.

The TPS61196 has a built-in linear regulator which steps down the input voltage to the V_{DD} voltage for powering the internal circuitry. A soft-start circuit is implemented internally to work with an external capacitor to adjust the soft start-up time to minimize the in-rush current during boost converter start-up. The device is available in a 28-pin HTSSOP package with PowerPAD™.

Device Information⁽¹⁾

PART NUMBER	PACKAGE	BODY SIZE (NOM)
TPS61196	HTSSOP (28)	9.70 mm x 4.40 mm

(1) For all available packages, see the orderable addendum at the end of the datasheet.

Simplified Schematic

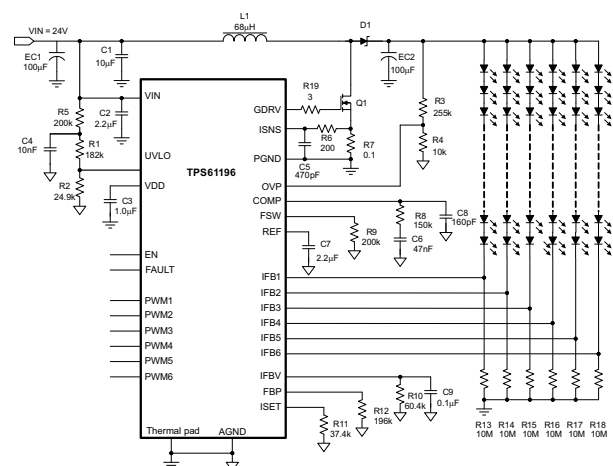

Table of Contents

1 Features 1 2 Applications 1 3 Description 1 4 Revision History 2 5 Pin Configuration and Functions 3 6 Specifications 4 6.1 Absolute Maximum Ratings 4 6.2 ESD Ratings 4 6.3 Recommended Operating Conditions 4 6.4 Thermal Information 5 6.5 Electrical Characteristics 5 6.6 Switching Characteristics 7 6.7 Typical Characteristics 8 7 Detailed Description 11 7.1 Overview 11	7.2 Functional Block Diagram 11 7.3 Feature Description 12 7.4 Device Functional Modes 16 8 Application and Implementation 19 8.1 Application Information 19 8.2 Typical Application 20 9 Power Supply Recommendations 23 10 Layout 24 10.1 Layout Guidelines 24 10.2 Layout Example 24 11 Device and Documentation Support 25 11.1 Trademarks 25 11.2 Electrostatic Discharge Caution 25 11.3 Glossary 25 12 Mechanical, Packaging, and Orderable Information 25
---	--

4 Revision History

NOTE: Page numbers for previous revisions may differ from page numbers in the current version.

Changes from Revision C (March 2013) to Revision D

Page

- Added *Device Information* and *ESD Rating* tables, *Feature Description*, *Device Functional Modes*, *Application and Implementation*, *Power Supply Recommendations*, *Layout*, *Device and Documentation Support*, and *Mechanical, Packaging, and Orderable Information* sections; moved some curves to *Application Curves* section; remove *Device Comparison* table 1
- Changed location of several specs from *EC* table to *Switching Char* 7

Changes from Revision B (January 2013) to Revision C

Page

- Changed V_L max value from 1.0 V to 0.8 V 5
- Changed $V_{IN} = 7$ V to $V_{IN} = 8$ V in Test Conditions for $V_{ISNS(OC)}$ 6

Changes from Revision A (November 2012) to Revision B

Page

- Changed R_{PD} max value from 2.4 M Ω to 3.0 M Ω 5
- Changed V_{ISET} min value from 1.220 V to 1.217 V 5
- Deleted I_{FLT_L} max value 6
- Changed R7 to R9 in [Table 1](#) 12

Changes from Original (October 2012) to Revision A

Page

- Changed [Figure 20](#) 14

5 Pin Configuration and Functions

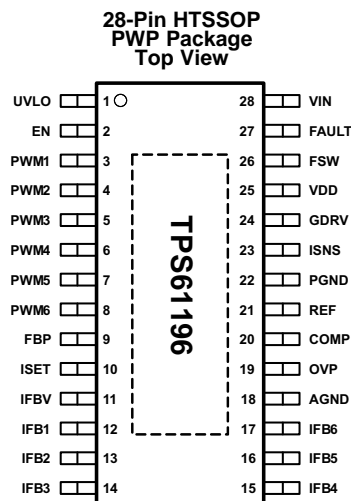

Pin Functions

PIN		TYPE	DESCRIPTION
NUMBER	NAME		
1	UVLO	I	Low input voltage lockout. Use a resistor divider from V_{IN} to this pin to set the UVLO threshold.
2	EN	I	Enable and disable pin. EN high = enable, EN low = disable.
3,4,5,6,7,8	PWM1 to PWM6	I	PWM signal input pins. The frequency of PWM signal is in the range of 90 Hz to 22 kHz.
9	FBP	O	LED cross-short protection threshold program pin. Use a resistor to GND to set the threshold.
10	ISET	O	Connecting a resistor to the pin programs the IFB pin current level for full brightness (that is, 100% dimming).
11	IFBV	O	Minimum feedback voltage setting for LED strings.
12,13,14,15,16,17	IFB1 to IFB6	I	Regulated current sink input pins
18	AGND	G	Analog ground
19	OVP	I	Overvoltage protection detection input. Connect a resistor divider from output to this pin to program the OVP threshold.
20	COMP	O	Loop compensation for the boost converter. Connect a RC network to make loop stable.
21	REF	O	Internal reference voltage for the boost converter. Use a capacitor at this pin to adjust the soft start time. When two chips operate in parallel, connect the master's REF pin to the slave's COMP pin.
22	PGND	G	External MOSFET current sense ground input.
23	ISNS	I	External MOSFET current sense positive input.
24	GDRV	o	External switch MOSFET gate driver output.
25	VDD	O	Internal regulator output for device internal power supply. Connect a 1- μ F ceramic capacitor to this pin.
26	FSW	O	Switching frequency setting pin. Use a resistor to set the frequency between 100 kHz to 800 kHz. An external input voltage above 3.5 V or below 0.5 V disables the internal clock and makes the device as slave device.
27	FAULT	O	Fault indicator. Open-drain output. Output high impedance when fault conditions happens.
28	VIN	I	Power supply input pin

6 Specifications

6.1 Absolute Maximum Ratings

over operating free-air temperature range (unless otherwise noted)⁽¹⁾

		MIN	MAX	UNIT
Voltage ⁽²⁾	V _{IN} pin	-0.3	33	V
	FAULT pin	-0.3	V _{IN}	
	FB1 to IFB6 pins	-0.3	40	
	FBP, ISET, ISNS, IFBV pins	-0.3	3.3	
	EN, PWM1 to PWM6 pins	-0.3	20	
	GDRV pins	-0.3	7	
	GDRV 10-ns transient pins	-2	9	
	All other pins	-0.3	7	
Continuous power dissipation		See Thermal Information		
Operating junction temperature		-40	150	°C
Storage temperature, T _{stg}		-65	150	°C

- (1) Stresses beyond those listed under *Absolute Maximum Ratings* may cause permanent damage to the device. These are stress ratings only, which do not imply functional operation of the device at these or any other conditions beyond those indicated under *Recommended Operating Conditions*. Exposure to absolute-maximum-rated conditions for extended periods may affect device reliability.
- (2) All voltage values are with respect to network ground terminal.

6.2 ESD Ratings

		VALUE	UNIT
V _(ESD) Electrostatic discharge	Human-body model (HBM), per ANSI/ESDA/JEDEC JS-001 ⁽¹⁾	±2000	V
	Charged-device model (CDM), per JEDEC specification JESD22-C101 ⁽²⁾	±1000	
	Machine model	200 (max)	

- (1) JEDEC document JEP155 states that 500-V HBM allows safe manufacturing with a standard ESD control process.
- (2) JEDEC document JEP157 states that 250-V CDM allows safe manufacturing with a standard ESD control process.

6.3 Recommended Operating Conditions

over operating free-air temperature range (unless otherwise noted)⁽¹⁾

		MIN	NOM	MAX	UNIT
V _{IN}	Input voltage	8		30	V
V _{OUT}	Output voltage	V _{IN}		120	V
L ₁	Inductor	10		100	μH
C _{IN}	Input capacitor	10			μF
C _{OUT}	Output capacitor	22		220	μF
f _{SW}	Boost regulator switching frequency	100		800	kHz
f _{DIM}	PWM dimming frequency	0.09		22	kHz
T _A	Operating ambient temperature	-40		85	°C
T _J	Operating junction temperature	-40		125	°C

- (1) Customers need to verify the component value in their application if the values are different from the recommended values.

6.4 Thermal Information

THERMAL METRIC ⁽¹⁾		TPS61196	UNIT
		PWP	
		28 PINS	
R _{θJA}	Junction-to-ambient thermal resistance	33.8	°C/W
R _{θJC(top)}	Junction-to-case (top) thermal resistance	18.8	
R _{θJB}	Junction-to-board thermal resistance	15.6	
ψ _{JT}	Junction-to-top characterization parameter	0.6	
ψ _{JB}	Junction-to-board characterization parameter	15.4	
R _{θJC(bot)}	Junction-to-case (bottom) thermal resistance	2.5	

(1) For more information about traditional and new thermal metrics, see the *IC Package Thermal Metrics* application report, [SPRA953](#).

6.5 Electrical Characteristics

V_{IN} = 24 V, minimum and maximum limits are at T_A = –40°C to +85°C, typical values are at T_A = 25°C, C1 = 10 μF, C2 = 2.2 μF, C3 = 1 μF, EC1 = EC2 = 100 μF (unless otherwise noted).

PARAMETER	TEST CONDITIONS	MIN	TYP	MAX	UNIT	
POWER SUPPLY						
V _{IN}	Input voltage range	8		30	V	
V _{VIN_UVLO}	Undervoltage lockout threshold	V _{IN} falling	6.5	7	V	
V _{VIN_HYS}	V _{IN} UVLO hysteresis		300		mV	
I _{q_VIN}	Operating quiescent current into VIN	Device enabled, no switching, V _{IN} = 30 V		2	mA	
I _{SD}	Shutdown current	V _{IN} = 12 V, V _{IN} = 30 V		25 50	μA	
V _{DD}	Regulation voltage for internal circuit	0 mA < I _{DD} < 15 mA	5.7	6	6.3	V
EN and PWMx						
V _H	Logic high input on EN, PWMx	V _{IN} = 8 V to 30 V	1.8		V	
V _L	Logic low input on EN, PWMx	V _{IN} = 8 V to 30 V		0.8	V	
R _{PD}	Pull-down resistance on EN, PWMx		0.8	1.6	3	MΩ
UVLO						
V _{UVLOTH}	Threshold voltage at UVLO pin		1.204	1.229	1.253	V
I _{UVLO}	UVLO input bias current	V _{UVLO} = V _{UVLOTH} – 50 mV V _{UVLO} = V _{UVLOTH} + 50 mV	–0.1 –4.3		0.1 –3.3	μA
SOFT START						
I _{SS}	Soft start charging current	PWM ON, V _{REF} < 2 V PWM ON, V _{REF} > 2 V		200 10		μA
CURRENT REGULATION						
V _{ISET}	ISET pin voltage		1.217	1.229	1.240	V
I _{ISET_P}	ISET short-to-ground protection threshold		120	150	180	μA
K _{ISET}	Current multiple I _{IFB} /I _{ISET}	I _{ISET} = 32.56 μA, V _{IFB} = 0.5 V	3932	3992	4052	
I _{IFB(AVG)}	Current accuracy	I _{ISET} = 32.56 μA, V _{IFB} = 0.5 V	127.4	130	132.6	mA
K _{IFB(M)}	Current matching: (I _{IFB(MAX)} – I _{IFB(MIN)})/2I _{IFB(AVG)}	I _{ISET} = 32.56 μA, V _{IFB} = 0.5 V		0.5%	1.5%	
I _{IFB_LEAK}	IFB pin leakage current at dimming off	IFB voltage < 40 V			1	μA
I _{IFB_max}	Current sink max output current	V _{IFBV} = 350 mV	130			mA

Electrical Characteristics (continued)

$V_{IN} = 24\text{ V}$, minimum and maximum limits are at $T_A = -40^\circ\text{C}$ to $+85^\circ\text{C}$, typical values are at $T_A = 25^\circ\text{C}$, $C_1 = 10\ \mu\text{F}$, $C_2 = 2.2\ \mu\text{F}$, $C_3 = 1\ \mu\text{F}$, $EC_1 = EC_2 = 100\ \mu\text{F}$ (unless otherwise noted).

PARAMETER	TEST CONDITIONS	MIN	TYP	MAX	UNIT		
IFB REGULATION VOLTAGE							
V_{IFB}	Regulation voltage at IFB	Measured on $V_{IFB(\text{min})}$, other IFB voltages are 0.5 V above $V_{IFB(\text{min})}$. $I_{IFB} = 130\ \text{mA}$, $V_{IFBV} = 0.5\ \text{V}$		508	mV		
I_{IFBV}	IFB Regulation voltage setting sourcing current at IFBV	$V_{IFBV} = 0.5\ \text{V}$		0.247	0.25	0.253	I_{SET}
V_{IFBV}	IFBV voltage setting range			0.3	1	V	
BOOST REFERENCE VOLTAGE							
V_{REF}	Reference voltage range for boost controller			0	3.1	V	
$I_{\text{REF_LEAK}}$	Leakage current at REF pin			-25	25	nA	
OSCILLATOR							
V_{FSW}	FSW pin reference voltage			1.8	V		
$V_{\text{FSW_H}}$	Logic high input voltage			3.5	V		
$V_{\text{FSW_L}}$	Logic low input voltage			0.5	V		
ERROR AMPLIFIER							
I_{SINK}	Comp pin sink current	$V_{\text{OVP}} = V_{\text{REF}} + 200\ \text{mV}$, $V_{\text{COMP}} = 1\ \text{V}$		20	μA		
I_{SOURCE}	Comp pin source current	$V_{\text{OVP}} = V_{\text{REF}} - 200\ \text{mV}$, $V_{\text{COMP}} = 1\ \text{V}$		20	μA		
G_{mEA}	Error amplifier transconductance			90	120	150	μS
R_{EA}	Error amplifier output resistance			20	M Ω		
GATE DRIVER							
$R_{\text{GDRV(SRC)}}$	Gate driver impedance when sourcing	$V_{\text{DD}} = 6\ \text{V}$, $I_{\text{GDRV}} = -20\ \text{mA}$		2	3	Ω	
$R_{\text{GDRV(SNK)}}$	Gate driver impedance when sinking	$V_{\text{DD}} = 6\ \text{V}$, $I_{\text{GDRV}} = 20\ \text{mA}$		1	1.5	Ω	
$I_{\text{GDRV(SRC)}}$	Gate driver source current	$V_{\text{GDRV}} = 5\ \text{V}$		200	mA		
$I_{\text{GDRV(SNK)}}$	Gate driver sink current	$V_{\text{GDRV}} = 1\ \text{V}$		400	mA		
$V_{\text{ISNS(OC)}}$	Overcurrent detection threshold	$V_{\text{IN}} = 8\ \text{V}$ to $30\ \text{V}$, $T_J = 25^\circ\text{C}$ to 125°C		376	400	424	mV
OVERVOLTAGE PROTECTION (OVP)							
V_{OVPTH}	Output voltage OVP threshold			2.95	3.02	3.09	V
I_{OVP}	Leakage current			-100	0	100	nA
$V_{\text{IFB_OVP}}$	IFBx over voltage threshold	PWM ON		38	V		
LED SHORT DETECTION							
I_{FBP}	LED short detection sourcing current	$V_{\text{FBP}} = 1\ \text{V}$		0.247	0.25	0.253	I_{SET}
FAULT INDICATOR							
$I_{\text{FLT_H}}$	Leakage current in high impedance	$V_{\text{FLT}} = 24\ \text{V}$		1	nA		
$I_{\text{FLT_L}}$	Sink current at low output	$V_{\text{FLT}} = 1\ \text{V}$		1	2	mA	
THERMAL SHUTDOWN							
T_{shutdown}	Thermal shutdown threshold			150	$^\circ\text{C}$		
T_{hys}	Thermal shutdown threshold hysteresis			15	$^\circ\text{C}$		

6.6 Switching Characteristics

over operating free-air temperature range (unless otherwise noted)

PARAMETER		TEST CONDITIONS	MIN	TYP	MAX	UNIT
f_{SW}	Switching frequency	$R_{FSW} = 200\text{ k}\Omega$	187	200	213	kHz
D_{max}	Maximum duty cycle	$f_{SW} = 200\text{ kHz}$	90%	94%	98%	
$t_{on(min)}$	Minimum pulse width			200		ns
f_{EA}	Error amplifier crossover frequency			1000		kHz

6.7 Typical Characteristics

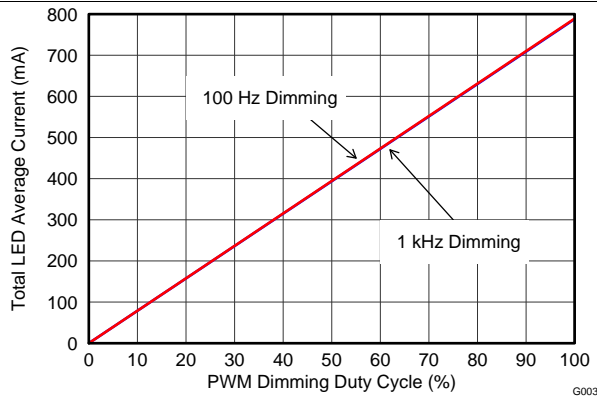

Figure 1. Dimming Linearity

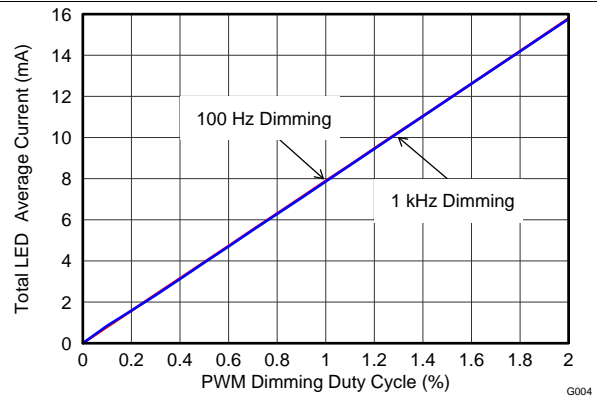

Figure 2. Dimming Linearity at Low Dimming Duty Cycle

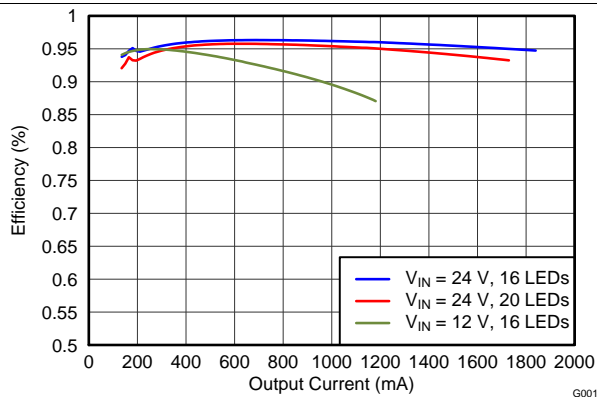

Figure 3. DC Load Efficiency

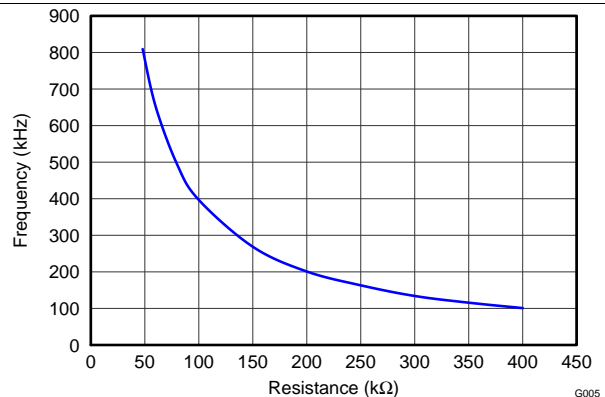

Figure 4. Switching Frequency Setting

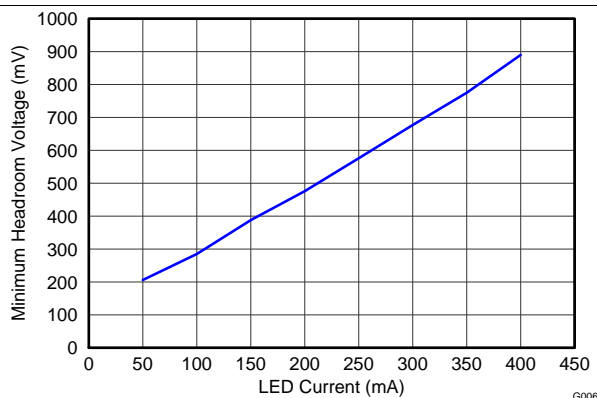

Figure 5. Recommended Minimum Headroom Voltage

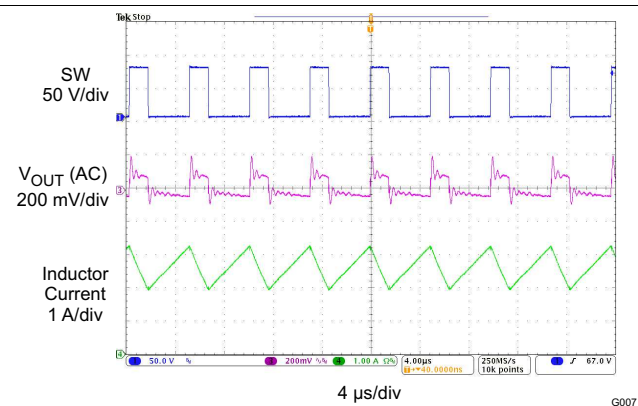

Figure 6. Boost Switching Waveform

Typical Characteristics (continued)

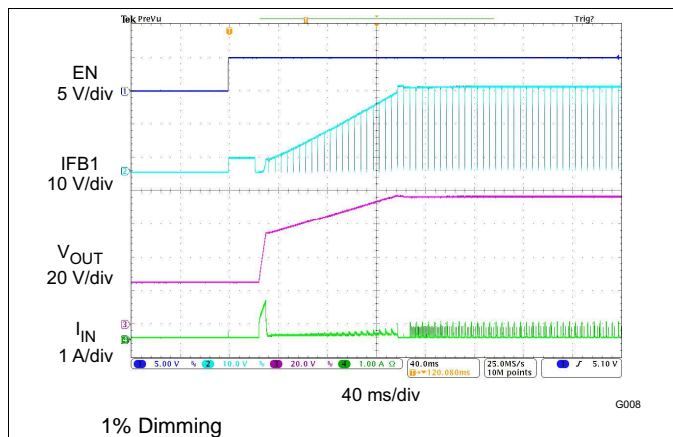

Figure 7. Start-up Waveform

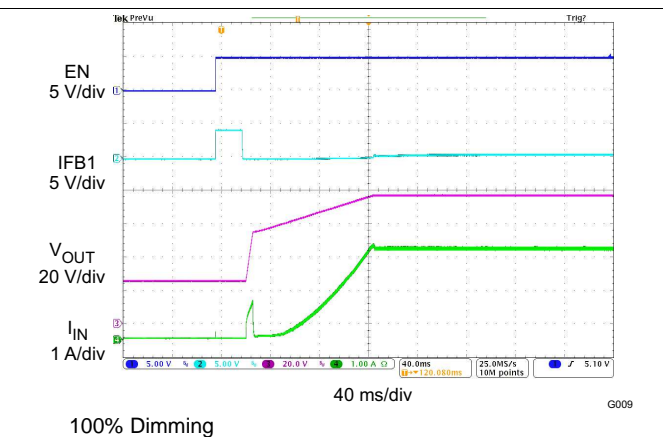

Figure 8. Start-up Waveform

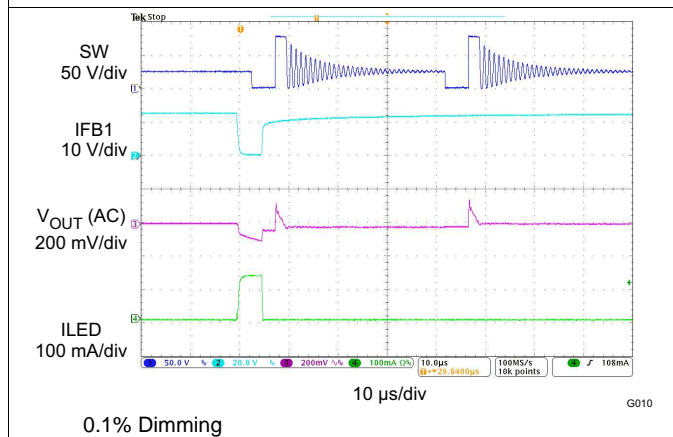

Figure 9. Dimming Waveform

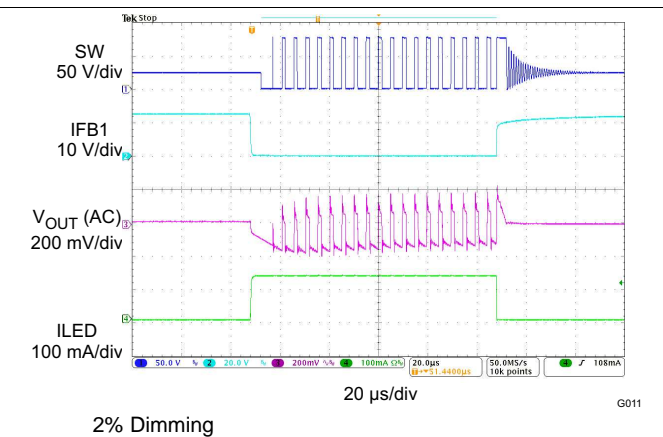

Figure 10. Dimming Waveform

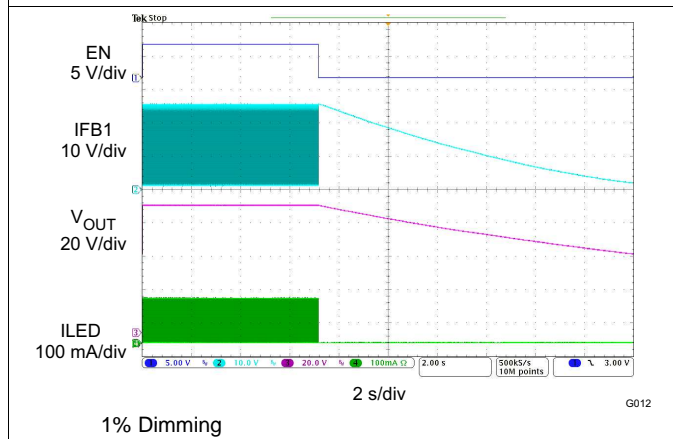

Figure 11. Shutdown Waveform

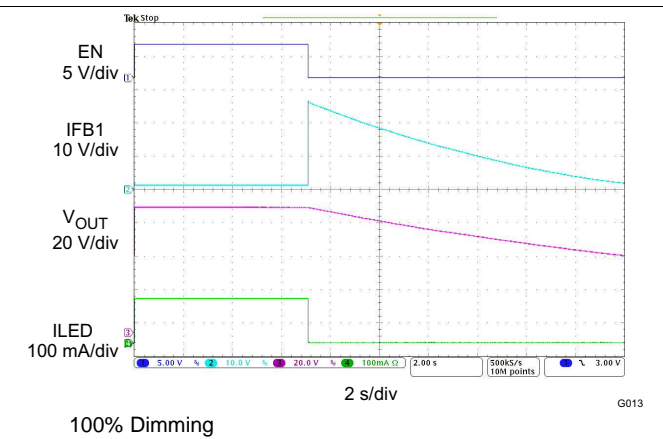

Figure 12. Shutdown Waveform

Typical Characteristics (continued)

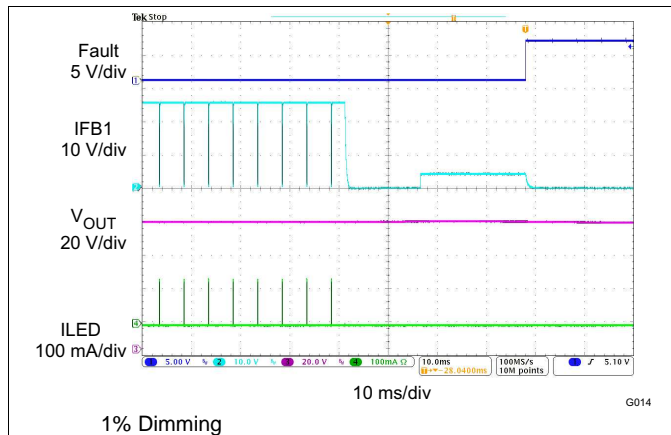

Figure 13. LED Open Protection

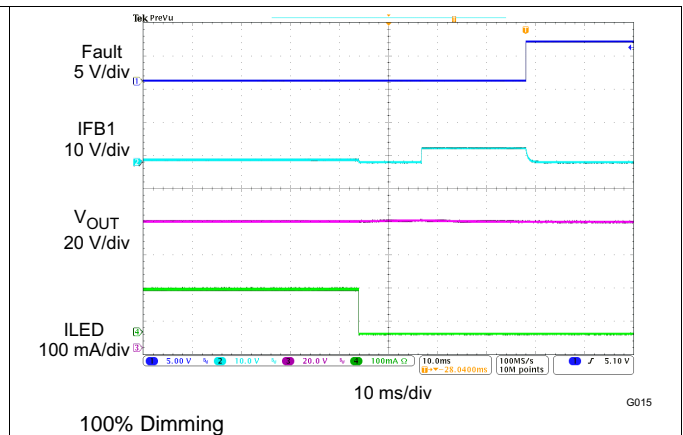

Figure 14. LED Open Protection

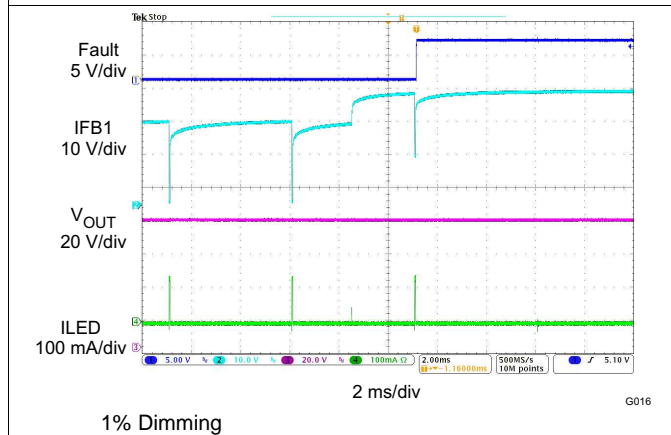

Figure 15. LED Short Protection

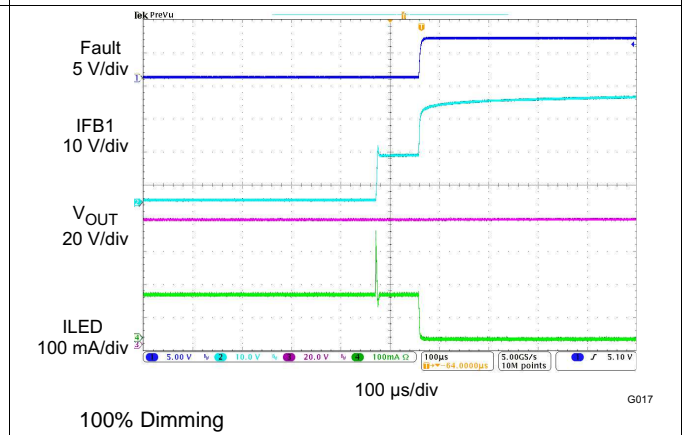

Figure 16. LED Short Protection

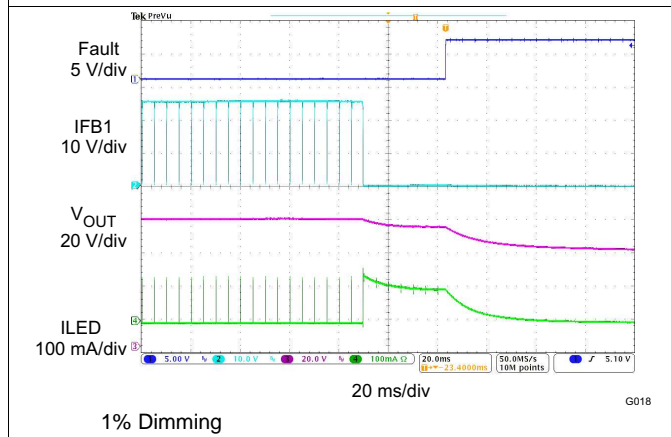

Figure 17. IFB Short-to-Ground Protection

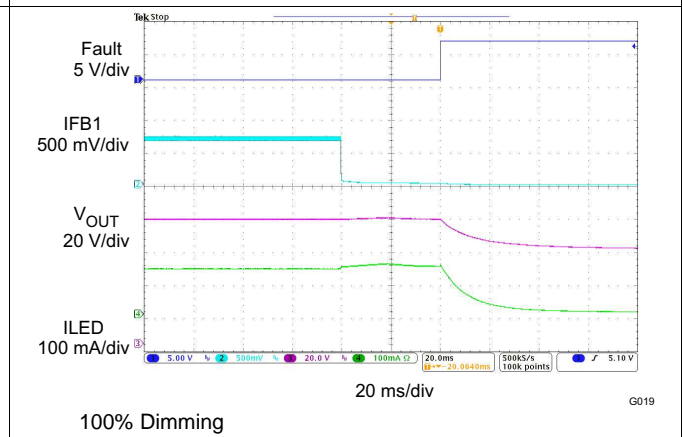

Figure 18. IFB Short-to-Ground Protection

7 Detailed Description

7.1 Overview

The TPS61196 provides a highly integrated solution for LCD TV backlight with an independent PWM dimming function for each string. This device is a current mode boost controller driving up to six WLED strings with multiple LEDs in series. Each string has an independent current regulator providing a LED current adjustable from 50 mA to 400 mA within $\pm 1.5\%$ matching accuracy. The minimal voltage at the current sink is programmable in the range of 0.3 V to 1 V to fit with different LED current settings. The input voltage range for the device is from 8 V to 30 V.

7.2 Functional Block Diagram

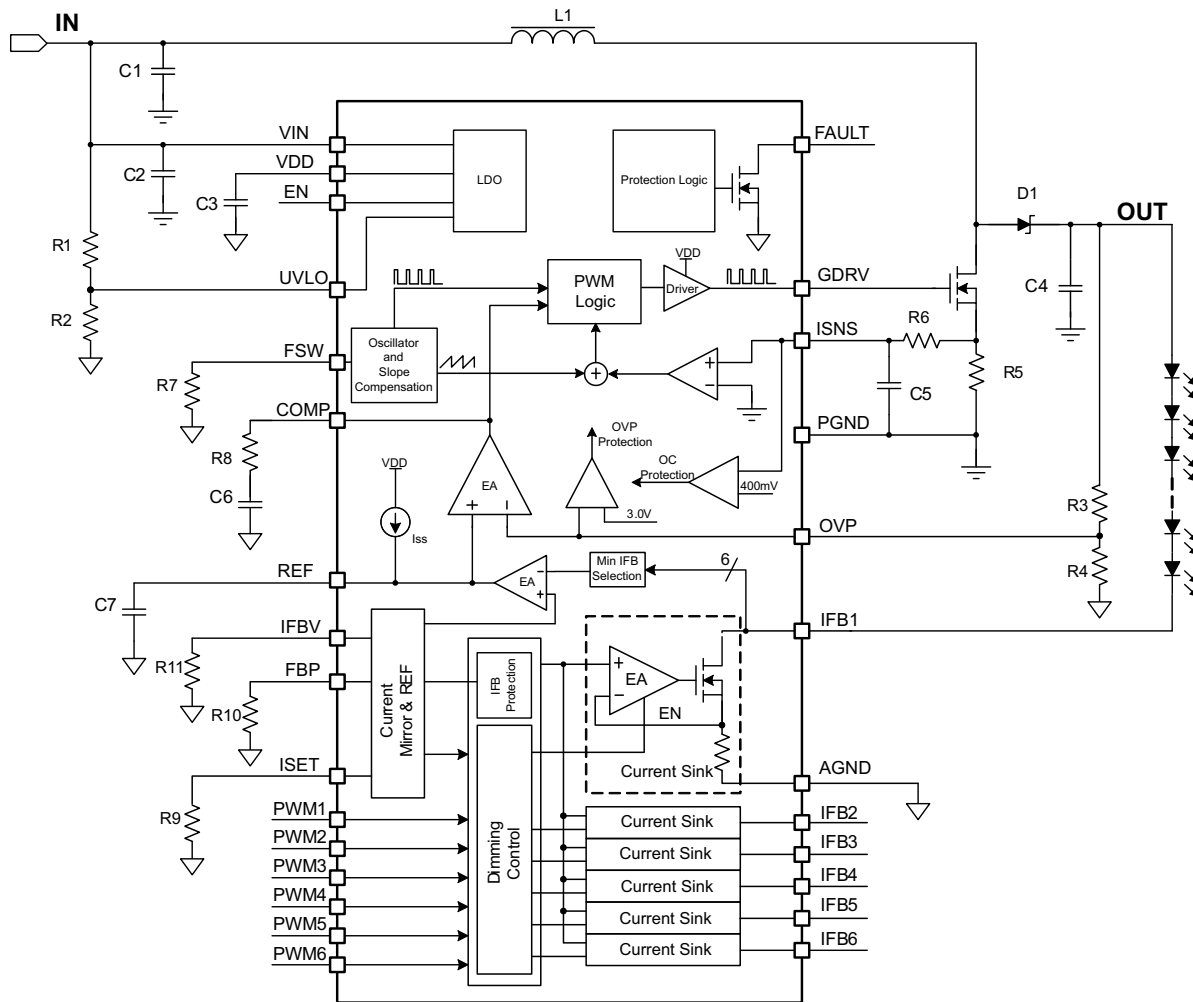

7.3 Feature Description

7.3.1 Supply Voltage

The TPS61196 has a built-in linear regulator to supply the device analog and logic circuitry. The VDD pin, output of the regulator, must be connected to a 1- μ F bypass capacitor. VDD only has a current sourcing capability of 15 mA. VDD voltage is ready after the EN pin is pulled high.

7.3.2 Boost Controller

The TPS61196 regulates the output voltage with current mode pulse width modulation (PWM) control. The control circuitry turns on an external switch FET at the beginning of each switching cycle. The input voltage is applied across the inductor and stores the energy as the inductor current ramps up. During this portion of the switching cycle, the load current is provided by the output capacitor. When the inductor current rises to the threshold set by the Error Amplifier (EA) output, the switch FET is turned off and the external Schottky diode is forward biased. The inductor transfers stored energy to replenish the output capacitor and supply the load current. This operation repeats each switching cycle. The switching frequency is programmed by an external resistor.

A ramp signal from the oscillator is added to the current ramp to provide slope compensation, shown in [Figure 23](#). The duty cycle of the converter is then determined by the PWM Logic block which compares the EA output and the slope compensated current ramp. The feedback loop regulates the OVP pin to a reference voltage generated by the minimum voltage across the IFB pins. The output of the EA is connected to the COMP pin. An external RC compensation network must be connected to the COMP pin to optimize the feedback loop for stability and transient response.

The TPS61196 consistently adjusts the boost output voltage to account for any changes in LED forward voltages. In the event that the boost controller is not able to regulate the output voltage due to the minimum pulse width ($t_{on(min)}$, in the [Electrical Characteristics](#)), the TPS61196 enters pulse skip mode. In this mode, the device keeps the power switch off for several switching cycles to prevent the output voltage from rising above the regulated voltage. This operation typically occurs in light load condition or when the input voltage is higher than the output voltage.

7.3.3 Switching Frequency

The switching frequency is programmed between 100 kHz to 800 kHz by an external resistor (R9 in [Figure 23](#)). To determine the resistance by a given frequency, use the curve in [Figure 4](#) or calculate the resistance value by [Equation 1](#). [Table 1](#) shows the recommended resistance values for some switching frequencies.

$$f_{sw} = \frac{40000}{R9} (\text{kHz}) \quad (1)$$

Table 1. Recommended Resistance Values For Switching Frequencies

R9	f_{sw}
400 k	100 kHz
200 k	200 kHz
100 k	400 kHz
80 k	500 kHz
48 k	800 kHz

7.3.4 Enable and Undervoltage Lockout

The TPS61196 is enabled with the soft start-up when the EN pin voltage is higher than 1.8 V. A voltage of less than 1 V disables the device.

An undervoltage lockout (UVLO) protection feature is provided. When the voltage at the VIN pin is less than 6.5 V, the TPS61196 is powered off. The TPS61196 resumes the operation once the voltage at the VIN pin recovers above the hysteresis (V_{VIN_HYS}) more than the UVLO threshold of input falling voltage. If a higher UVLO voltage is required, use the UVLO pin as shown in [Figure 19](#) to adjust the input UVLO threshold by using an external resistor divider. Once the voltage at the UVLO pin exceeds the 1.229-V threshold, the device is powered on, and

a hysteresis current source of 3.9 μA is added. When the voltage at the UVLO pin drops lower than 1.229 V, the current source is removed. The resistors of R1, R2, and R5 can be calculated by Equation 2 from required V_{START} and V_{STOP} . To avoid noise coupling, the resistor divider R1 and R2 must be close to the UVLO pin. Placing a filter capacitor of more than 10 nF as shown in Figure 19 can eliminate the impact of the switching ripple and improve the noise immunity.

If the UVLO function is not used, pull up the UVLO pin to the VDD pin.

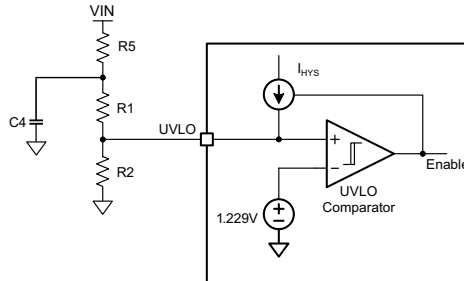

Figure 19. Undervoltage Lockout Circuit

$$R1 + R5 = \frac{V_{\text{START}} - V_{\text{STOP}}}{I_{\text{HYS}}}$$

$$R2 = (R1 + R5) \times \frac{1.229\text{V}}{V_{\text{START}} - 1.229\text{V}}$$

where

- I_{HYS} is 3.9 μA sourcing current from the UVLO pin. (2)

When the UVLO condition happens, the FAULT pin outputs high impedance. As long as the UVLO condition removes, the FAULT pin outputs low impedance.

7.3.5 Power-up Sequencing and Soft Start-up

The input voltage, UVLO pin voltage, EN input signal and the input dimming PWM signal control the power up of the TPS61196. After the input voltage is above the required minimal input voltage of 7.5 V, the internal circuit is ready to be powered up. After the UVLO pin is above the threshold of 1.229 V and the EN signal is high, the internal LDO and logic circuit are activated. The device outputs a 20-ms pulse to detect the unused channels and remove them from the control loop. When any PWM dimming signal is high, the soft start-up begins. If the PWM dimming signals come before the EN signal is high, the soft start-up begins immediately after the detection of unused channels.

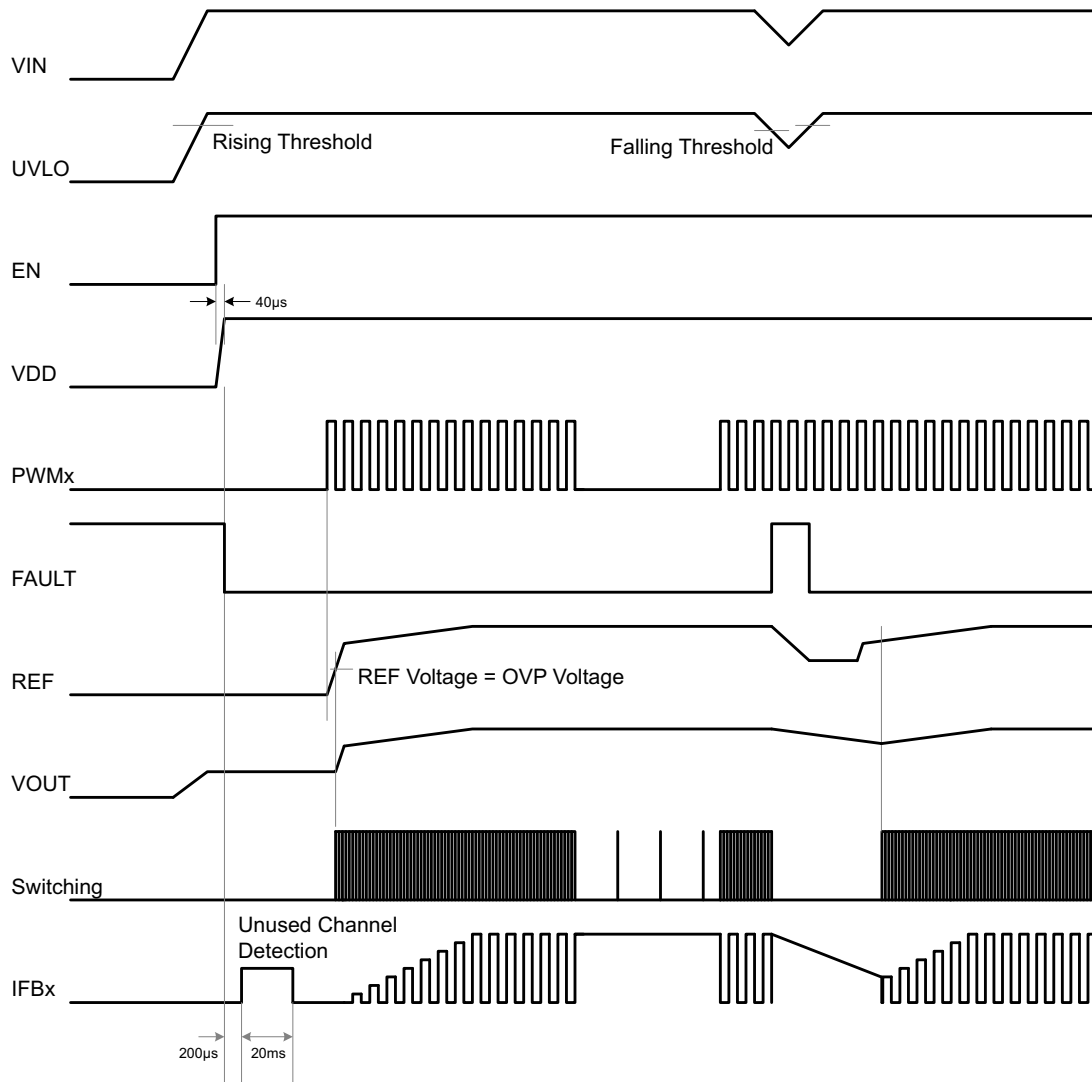
Figure 20. Power-Up Sequencing

The TPS61196 has integrated the soft-start circuitry working with an external capacitor at the REF pin to avoid inrush current during start-up. During the start-up period, the capacitor at the REF pin is charged with a soft-start current source. When the REF pin voltage is higher than the output feedback voltage at the OVP pin, the boost controller starts switching and the output voltage starts to ramp up. At the same time, the LED current sink starts to drive the LED strings. At the beginning of the soft start, the charge current is 200 µA. Once the voltage of the REF pin exceeds 2 V, the charge current changes to 10 µA and continues to charge the capacitor. When the current sinks are driving the LED strings, the IFB voltages are monitored. When the minimum IFB voltage is above 200 mV less than the setting voltage at the IFBV pin, the charge current is stopped, and the soft start-up is finished. The TPS61196 enters normal operation to regulate the minimum IFB voltage to the required voltage set by the resistor at the IFBV pin. The total soft start time is determined by the external capacitance. The capacitance must be within 1 µF to 4.7 µF for different start-up time and different output voltage.

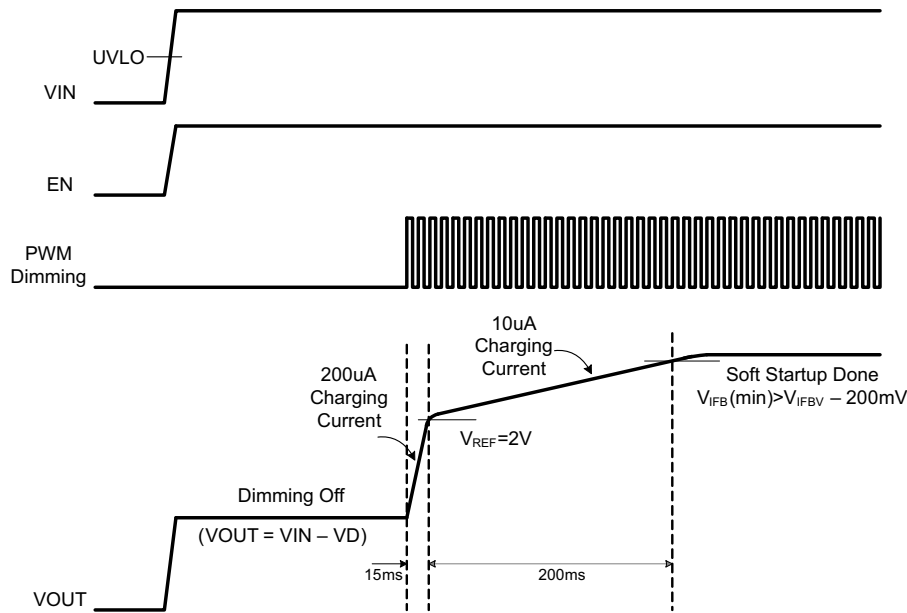

Figure 21. Soft-Start Waveforms

7.3.6 Unused LED String

If the application requires less than six LED strings, the TPS61196 simply requires connecting the unused IFB pin to ground through a resistor between 20 kΩ and 36 kΩ. Once the TPS61196 is turned on, the TPS61196 uses a 60-µA current source to detect the IFB pin voltage. If the IFB voltage is between 1 V and 2.5 V, the device immediately disables this string during start-up.

7.3.7 Current Regulation

The six channel current sink regulators can be configured to provide up to 400 mA per string. The expected LED current is programmed by a resistor (R11 in [Figure 23](#)) at the ISET using [Equation 3](#).

$$I_{LED} = \frac{V_{ISET}}{R11} \times K_{ISET}$$

where

- V_{ISET} is the ISET pin voltage of 1.229 V
- K_{ISET} is the current multiple of 3992.

To sink the set LED current, the current sink regulator requires a minimum headroom voltage at the IFB pins for working properly. For example, when the LED current is set to 130 mA, the minimum voltage required at the IFB pin must be higher than 0.35 V. For other LED currents, refer to [Figure 5](#) for recommended minimum headroom voltage required. The TPS61196 regulates the minimum voltage of the IFB pins to the IFBV voltage. The IFBV voltage is adjustable with an external resistor (R10 in the [Figure 23](#)) at the IFBV pin. After choosing the minimum IFB voltage, the IFBV voltage must be set to this value and the setting resistance can be calculated by [Equation 4](#).

$$V_{IFBV} = \frac{R10}{R11} \times 307.3(\text{mV})$$

If a large LED current is set, the headroom voltage is required higher. This leads to more heat on the device. To maintain the total power dissipation in the range of the package limit, normally all strings can not sink large current in continuous mode but pulse mode. The backlight of an active shutter glass 3-D TV may work with large LED current in pulse mode.

7.3.8 PWM Dimming

LED brightness dimming is set by applying an external PWM signal of 90 Hz to 22 kHz to the PWM pins. Each LED string has an independent PWM input. Varying the PWM duty cycle from 0% to 100% adjusts the LED from minimum to maximum brightness respectively. The recommended minimum on time of the LED string is 10 μsec. Thus, the device has a minimum dimming duty cycle of 500:1 at 200 Hz.

When all PWM voltages are pulled low during dimming off, the TPS61196 turns off the LED strings and keeps the boost converter running at PFM mode. The output voltage is kept at the level which is a little bit lower than that when PWM is high. Thus, the device limits the output ripple due to the load transient that occurs during PWM dimming.

When all PWM voltages are pulled low for more than 20 ms, to avoid the REF pin voltage dropping due to the leakage current, the voltage of the REF pin is held by an internal reference voltage which equals to the REF pin voltage in normal dimming operation. Thus, the output voltage will be kept at the same level as the normal output voltage.

Since the output voltage in long time dimming off status is almost the same as the normal voltage for turning the LED on, the TPS61196 turns on the LED very fast without any flicker when recovering from long time dimming off to small duty cycle dimming on.

7.4 Device Functional Modes

7.4.1 Protections

The TPS61196 has a full set of protections making the system safe to any abnormal conditions. Some protections will latch the TPS61196 in off state until its power supply is recycled or it is disabled and then enabled again. In latch off state, the REF pin voltage is discharged to 0 V.

7.4.1.1 Switch Current Limit Protection Using the ISNS Pin

The TPS61196 monitors the inductor current through the voltage across a sense resistor (R7 in the [Figure 23](#)) in order to provide current limit protection. During the switch FET on period, when the voltage at the ISNS pin rises above 400 mV (V_{ISNS} in the [Electrical Characteristics](#) table), the TPS61196 turns off the FET immediately and does not turn it back on until the next switch cycle. The switch current limit is equal to 400 mV / R7.

7.4.1.2 LED Open Protection

When one of the LED strings is open, the voltage at the IFB pin connecting to this LED string drops to zero during dimming-on time. The TPS61196 monitors the IFB voltage for 20 ms. If the IFB voltage is still below the threshold of 0.2 V, the current sink is disabled and an internal pull-up current is activated to detect the IFB voltage again. If the IFB voltage is pulled up to a high voltage, this LED string is recognized as LED open. As a result, the device deactivates the open IFB pin and removes it from the voltage feedback loop. Afterwards, the output voltage returns to the voltage required for the connected LED strings. The IFB pin currents of the connected strings remain in regulation during this process. If all the LED strings are open, the TPS61196 is latched off.

7.4.1.3 LED Short-Cross Protection Using the FBP Pin

If one or several LEDs short in one string, the corresponding IFB pin voltage rises but continues to sink the LED current, causing increased device power dissipation. To protect the device, the TPS61196 provides a programmable LED short-across protection feature by properly sizing the resistor on the FBP pin (R12 in [Figure 23](#)) using [Equation 5](#).

$$V_{LED_SHORT} = \frac{R12}{R11} \times 1.229V \quad (5)$$

If any IFB pin voltage exceeds the threshold (V_{LED_SHORT}), the device turns off the corresponding current sink and removes this IFB pin from the output voltage regulation loop. Current regulation of the remaining IFB pins is not affected.

Device Functional Modes (continued)

7.4.1.4 Schottky Diode Open Protection

When the device is powered on, it checks the topology connection first. After the TPS61196 delays 400 μ s, it checks the voltage at the OVP pin to see if the Schottky diode is not connected or the boost output is hard-shortened to ground. If the voltage at the OVP pin is lower than 70 mV, the TPS61196 is locked in off state until the input power is recycled or it is enabled again.

7.4.1.5 Schottky Diode Short Protection

If the rectifier Schottky diode is shorted, the reverse current from output capacitor to ground is very large when the switcher MOSFET is turned on. Because the current mode control topology has a minimum edge blanking time to immunize against the spike current through the switcher, if the parasite inductance between the output capacitor through the switcher to ground is zero, the external MOSFET will be damaged in this short period due to the huge power dissipation in this case. But with a small parasite inductance, the power dissipation is limited. The boost converter works in minimum pulse width in this situation due to cycle by cycle over-current protection. The output voltage drops and the all-string-open protection is triggered because of the low voltage at all IFB pins. The TPS61196 is latched off.

7.4.1.6 IFB Overvoltage Protection During Start-up

When any of IFB pins reaches the threshold (V_{OVP_IFB}) of 38 V during start-up, the device stops switching and stays in latch-off immediately to protect from damage. In latch-off state, the REF pin voltage is discharged.

7.4.1.7 Output Overvoltage Protection Using the OVP Pin

Use a resistor divider to program the maximum output voltage of the boost converter. To ensure the LED string can be turned on with setting current, the maximum output voltage must be higher than the forward voltage drop of the LED string. The maximum required voltage can be calculated by multiplying the maximum LED forward voltage ($V_{FWD(max)}$) and number (n) of series LEDs, and adding extra 1 V to account for regulation and resistor tolerances and load transients.

The recommended bottom feedback resistor of the resistor divider (R4 in [Figure 23](#)) is 10 k Ω . Calculate the top resistor (R3 in the [Figure 23](#)) using [Equation 6](#), where V_{OVP} is the maximum output voltage of the boost converter.

$$R3 = \left(\frac{V_{OVP}}{3.02} - 1 \right) \times R4 \quad (6)$$

When the device detects that the voltage at the OVP pin exceeds overvoltage protection threshold of 3.02 V, indicating that the output voltage has exceeded the clamp threshold voltage, the TPS61196 clamps the output voltage to the set threshold. When the OVP pin voltage does not drop from the OVP threshold for more than 500 ms, the device is latched off until the input power or the EN pin voltage is re-cycled.

7.4.1.8 Output Short-to-Ground Protection

When the inductor peak current reaches twice the switch current limit in each switching cycle, the device immediately disables the boost controller until the fault is cleared. This protects the device and external components from damage if the output is shorted to ground.

7.4.1.9 IFB Short-to-Ground Protection

The IFB pin short to ground makes the LED current uncontrollable if there is no protection. If the device tries to increase the boost converter's output voltage to lift the IFB voltage, it will make the situation worse and the LED string may be burned due to the high current. The TPS61196 implements a protection mechanism to protect the LED string in this failure mode.

If the IFB is short to ground before the TPS61196 is turned on, the device detects the IFB voltage by sourcing a 60 μ A current during start-up. If the IFB voltage is less than 0.4 V during start-up, the start-up stops and the device outputs fault indication so as to protect the LED string during start-up.

Device Functional Modes (continued)

When a LED feedback pin is shorted to ground during normal operation, the device first turns off this LED string for a very short time and detects the IFB voltage again. If the IFB voltage is lower than 1.8 V, it sources a 60- μ A current and detects the IFB voltage again in off state. If the IFB voltage is still less than 1.8 V, this means the IFB pin is shorted to ground. The boost converter is turned off and the REF voltage is discharged to ground to protect the LED string.

7.4.1.10 ISET Short-to-Ground Protection

The TPS61196 monitors the ISET pin voltage when the device is enabled. When the sourcing current from the ISET pin is larger than a threshold of 150 μ A, the device disables the current sink because the ISET pin may be short to ground or the current setting resistor is too small. Once the current sourcing from the ISET pin recovers to the normal value, the current sink resumes working.

7.4.1.11 Thermal Protection

When the device junction temperature is over 150°C, the thermal protection circuit is triggered and shuts down the device immediately. The device automatically restarts when the junction temperature falls back to less than 135°C, with approximate 15°C hysteresis.

Table 2. Protection List

PROTECTION ITEM	RESULT	FAULT	LATCH OFF / RETRY
Diode open	Cannot start up	Y	Latch off
Diode short	Output voltage low	Y	Latch off
LED string open	LED string off	Y	LED string latch off
LED string short during start-up	IFB OVP	Y	Latch off
LEDshort	LED string off	Y	LED string latch off
IFB short to GND	Boost off	Y	Latch off
ISET short to GND	All LED strings off	Y	Retry
All LED strings open during start-up	VOUT OVP	Y	Latch off
Input voltage UVLO	Boost off	Y	Retry
Thermal shutdown	Shutdown	Y	Retry

7.4.2 Indication For Fault Conditions

The TPS61196 has an open-drain fault indicator pin to indicate abnormal conditions. When the device is operating normally, the voltage at the FAULT pin is low. When any fault condition happens, it is in high impedance, which can be pulled to high level through an external resistor. The FAULT pin can indicate following conditions:

- Overvoltage condition at the OVP or the IFB pin
- LED short and open
- IFB short to ground
- ISET short to ground
- Diode open and short
- Output short circuit
- Overtemperature

8 Application and Implementation

NOTE

Information in the following applications sections is not part of the TI component specification, and TI does not warrant its accuracy or completeness. TI's customers are responsible for determining suitability of components for their purposes. Customers should validate and test their design implementation to confirm system functionality.

8.1 Application Information

When more LED strings are required in the application, the TPS61196 can work in master/slave mode. The TPS61196 can be set as slave device when the voltage at the FSW pin is below 0.5 V or above 3.5 V. The master TPS61196 has booster controller and outputs the power rail for all LED strings. The slave TPS61196 only works as a LED driver and feedbacks the required headroom voltage to the master by connecting the slave's COMP pin to the master's REF pin. The ISNS pin of the slave TPS61196 must be connected to ground. The slave's OVP pin voltage must be 3% higher than the voltage at the master's OVP pin. The slave device can combine all fault conditions happening on both master and slave devices by connecting the master's FAULT output to the FSW pin of the slave device. The slave's FAULT pin outputs the indication signal for all fault conditions.

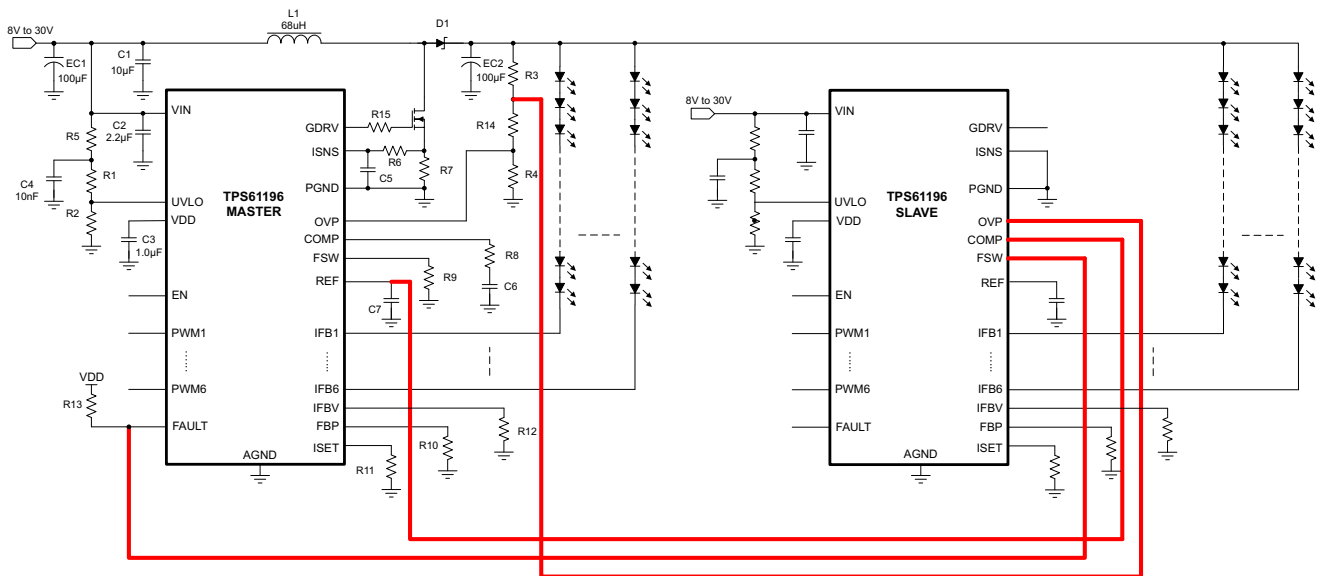

Figure 22. Multi-Chip Operation In Parallel

8.2 Typical Application

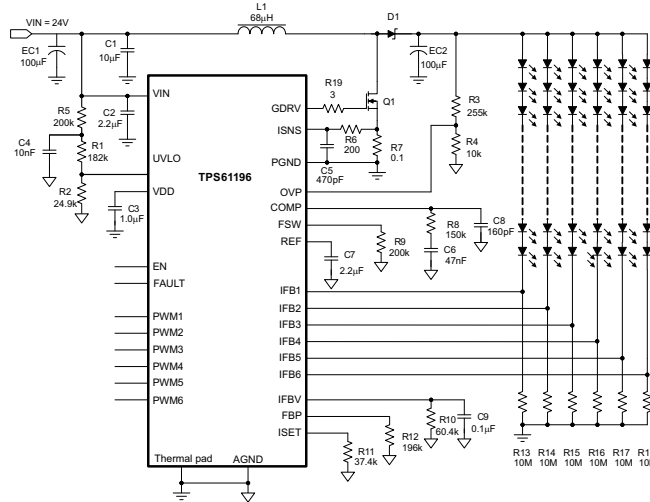

Figure 23. TPS61196 Typical Application

8.2.1 Design Requirements

8.2.1.1 Design Requirements

DESIGN PARAMETER	EXAMPLE VALUE
Input voltage range	10 V – 15 V
LED forward voltage range	56 V - 64 V
Number of LED strings × number of LEDs per string	6 x 20
LED string current	150 mA per channel
Switching frequency	500 kHz

8.2.2 Detailed Design Procedure

8.2.2.1 Inductor Selection

The inductor is the most important component in switching power regulator design because it affects power supply steady state operation, transient behavior, and loop stability. The inductor value, DC resistance (DCR), and saturation current are important specifications to be considered for better performance. Although the boost power stage can be designed to operate in discontinuous mode at maximum load, where the inductor current ramps down to zero during each switching cycle, most applications will be more efficient if the power stage operates in continuous conduction mode, where a DC current flows through the inductor. Therefore, the Equation 8 and Equation 9 below are for CCM operation only. The TPS61196 is designed to work with inductor values between 10 µH and 100 µH, depending on the switching frequency. Running the controller at higher switching frequencies allows the use of smaller and/or lower profile inductors in the 10-µH range. Running the controller at slower switching frequencies requires the use of larger inductors, near 100 µH, to maintain the same inductor current ripple but may improve overall efficiency due to smaller switching losses. Inductor values can have ±20% tolerance with no current bias. When the inductor current approaches saturation level, its inductance can decrease 20% to 35% from the 0-A value depending on how the inductor vendor defines saturation.

In a boost regulator, the inductor DC current can be calculated with Equation 7.

$$I_{L(DC)} = \frac{V_{OUT} \times I_{OUT}}{V_{IN} \times \eta}$$

where

- V_{OUT} = boost output voltage
- I_{OUT} = boost output current

- V_{IN} = boost input voltage
 - η = power conversion efficiency, use 95% for TPS61196 applications
- (7)

The inductor current peak-to-peak ripple can be calculated with [Equation 8](#).

$$\Delta I_{L(P-P)} = \frac{V_{IN} \times (V_{OUT} - V_{IN})}{L \times f_{SW} \times V_{OUT}}$$

where

- $\Delta I_{L(P-P)}$ = inductor ripple current
 - L = inductor value
 - f_{SW} = switching frequency
 - V_{OUT} = boost output voltage
 - V_{IN} = boost input voltage
- (8)

Therefore, the inductor peak current is calculated with [Equation 9](#).

$$I_{L(P)} = I_{L(DC)} + \frac{\Delta I_{L(P-P)}}{2}$$
(9)

Select an inductor, which saturation current is higher than calculated peak current. To calculate the worst-case inductor peak current, use the minimum input voltage, maximum output voltage, and maximum load current.

Regulator efficiency is dependent on the resistance of its high current path and switching losses associated with the switch FET and power diode. Besides the external switch FET, the overall efficiency is also affected by the inductor DCR. Usually the lower DC resistance shows higher efficiency. However, there is a trade-off between DCR and the inductor footprint; furthermore, shielded inductors typically have higher DCR than unshielded ones.

8.2.2.2 Schottky Diode

The TPS61196 demands a high-speed rectification for optimum efficiency. Ensure that the diode's average and peak current rating exceed the output LED current and inductor peak current. In addition, the diode's reverse breakdown voltage must exceed the application output voltage.

8.2.2.3 Switch MOSFET and Gate Driver Resistor

The TPS61196 demands a power N-MOSFET (see Q1 in the [Figure 23](#)) as a switch. The voltage and current rating of the MOSFET must be higher than the application output voltage and the inductor peak current. The applications benefit from the addition of a resistor (See R19 in the [Figure 23](#)) connected between the GDRV pin and the gate of the switch MOSFET. With this resistor, the gate driving current is limited and the EMI performance is improved. A 3- Ω resistor value is recommended. The TPS61196 exhibits lower efficiency when the resistor value is above 3 Ω due to the more switching loss of the external MOSFET.

8.2.2.4 Current Sense and Current Sense Filtering

R7 determines the correct overcurrent limit protection. To choose the right value of R7, start with the total system power needed P_{OUT} , and calculate the input current I_{IN} by [Equation 7](#). Efficiency can be estimated between 90% to 95%. The second step is to calculate the inductor peak current based on the inductor value L using [Equation 8](#) and [Equation 9](#). The maximum R7 can now be calculated as $R7(max) = V_{ISNS} / I_{L(P)}$. It is recommended to add 20% or more margins to account for component variations. A small filter placed on the ISNS pin improves performance of the converter (See R6 and C5 in [Figure 23](#)). The time constant of this filter should be approximately 100 ns. The range of R6 should be from about 100 Ω to 1 k Ω for best results. The C5 should be located as close as possible to the ISNS pin to provide noise immunity.

8.2.2.5 Output Capacitor

The output capacitor is mainly selected to meet the requirements for output ripple and loop stability of the whole system. This ripple voltage is related to the capacitance of the capacitor and its equivalent series resistance (ESR). Assuming a capacitor with zero ESR, the minimum capacitance needed for a given ripple can be calculated by:

$$V_{\text{RIPPLE}(C)} = \frac{I_{\text{OUT}} \times D_{\text{MAX}}}{f_{\text{SW}} \times C_{\text{OUT}}}$$

where

- V_{RIPPLE} is the peak to peak output voltage ripple
- D_{MAX} is the duty cycle of the boost converter. (10)

D_{MAX} is approximately equal to $(V_{\text{OUT}(\text{MAX})} - V_{\text{IN}(\text{MIN})} / V_{\text{OUT}(\text{MAX})}$) in applications. Care must be taken when evaluating a capacitor's derating under DC bias. The DC bias can also significantly reduce capacitance. Ceramic capacitors can lose as much as 50% of its capacitance at its rated voltage. Therefore, leave the margin on the voltage rating to ensure adequate capacitance.

The ESR impact on the output ripple must be considered as well if tantalum or aluminum electrolytic capacitors are used. Assuming there is enough capacitance such that the ripple due to the capacitance can be ignored, the ESR needed to limit the V_{RIPPLE} is:

$$V_{\text{RIPPLE}(\text{ESR})} = I_{\text{L}(\text{P})} \times \text{ESR} \quad (11)$$

Ripple current flowing through a capacitor's ESR causes power dissipation in the capacitor. This power dissipation causes a temperature increase internally to the capacitor. Excessive temperature can seriously shorten the expected life of a capacitor. Capacitors have ripple current ratings that are dependent on ambient temperature and should not be exceeded. Therefore, high ripple current type electrolytic capacitor with small ESR is used in typical application as shown in [Figure 23](#).

In the typical application, the output requires a capacitor in the range of 22 μF to 220 μF . The output capacitor affects the small signal control loop stability of the boost converter. If the output capacitor is below the range, the boost regulator may potentially become unstable.

8.2.2.6 Loop Consideration

The COMP pin on the TPS61196 is used for external compensation, allowing the loop response to be optimized for each application. The COMP pin is the output of the internal trans-conductance amplifier. The external resistor R8, along with ceramic capacitors C6 and C8 (see in [Figure 23](#)), are connected to the COMP pin to provide poles and zero. The poles and zero, along with the inherent pole and zero in a peak current mode control boost converter, determine the closed loop frequency response. This is important to converter stability and transient response.

The first step is to calculate the pole and the right half plane zero of the peak current mode boost converter by [Equation 12](#) and [Equation 13](#).

$$f_{\text{P}} = \frac{2I_{\text{OUT}}}{2\pi V_{\text{OUT}} \times C_{\text{OUT}}} \quad (12)$$

$$f_{\text{ZRHP}} = \frac{V_{\text{OUT}} \times (1-D)^2}{2\pi L \times I_{\text{OUT}}} \quad (13)$$

To make the loop stable, the loop must have sufficient phase margin at the crossover frequency where the loop gain is 1. To avoid the effect of the right half plane zero on the loop stability, choose the crossover frequency less than 1/5 of the f_{ZRHP} . Then calculate the compensation components by [Equation 14](#) and [Equation 15](#).

$$R8 = \frac{R7 \times 2\pi f_{\text{CO}} \times C_{\text{OUT}}}{(1-D) \times G_{\text{mEA}}} \times \frac{V_{\text{OVP}}}{V_{\text{OVPTH}}}$$

where

- $V_{\text{OVPTH}} = 3.02 \text{ V}$ which is the internal reference for the output overvoltage-protection setting voltage.
- G_{mEA} is the trans-conductance of the error amplifier. Its typical value is 120 μS .
- f_{CO} is the crossover frequency, which normally is less than 1/5 of the f_{ZRHP} (14)

$$C6 = \frac{1}{2\pi f_p \times R8}$$

where

- f_p is the pole's frequency of the power stage calculated by Equation 12 (15)

If the output capacitor is the electrolytic capacitor, which may have large ESR, a capacitor is required to cancel the zero of the output capacitor. Equation 16 calculates the value of this capacitor.

$$C8 = \frac{C_{OUT} \times R_{ESR}}{R8} \quad (16)$$

8.2.3 Application Curves

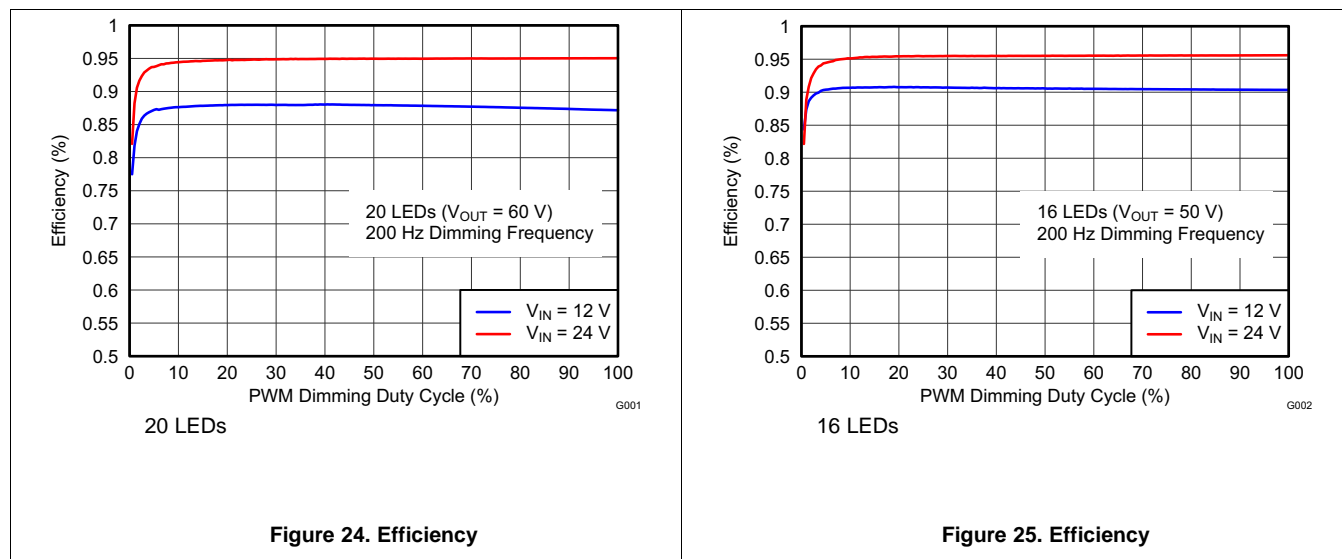

9 Power Supply Recommendations

The TPS61196 requires a single supply input voltage. This voltage can range between 8 V to 30 V and be able to supply enough current for a given application.

10 Layout

10.1 Layout Guidelines

As for all switching power supplies, especially those providing high current and using high switching frequencies, layout is an important design step. If layout is not carefully done, the regulator could show instability as well as EMI problems. Therefore, use wide and short traces for high current paths. The VDD capacitor, C3 (see [Figure 23](#)) is the filter and noise decoupling capacitor for the internal linear regulator powering the internal digital circuits. It should be placed as close as possible between the VDD and PGND pins to prevent any noise insertion to digital circuits. The switch node at the drain of Q1 carries high current with fast rising and falling edges. Therefore, the connection between this node to the inductor and the schottky diode should be kept as short and wide as possible. It is also beneficial to have the ground of the capacitor C3 close to the ground of the current sense resistor R7 since there is large driving current flowing between them. The ground of output capacitor EC2 should be kept close to input power ground or through a large ground plane because of the large ripple current returning to the input ground. When laying out signal grounds, it is recommended to use short traces separate from power ground traces and connect them together at a single point, for example on the thermal pad in the PWP package. Resistors R3, R4, R9, R10, R11, and R12 (see [Figure 23](#)) are setting resistors for switching frequency, LED current, protection threshold and feedback voltage programming. To avoid unexpected noise coupling into the pins and affecting the accuracy, these resistors need to be close to the pins with short and wide traces to GND. In the PWP package, the thermal pad needs to be soldered to the large ground plane on the PCB for better thermal performance. Additional thermal via can significantly improve power dissipation of the device.

10.2 Layout Example

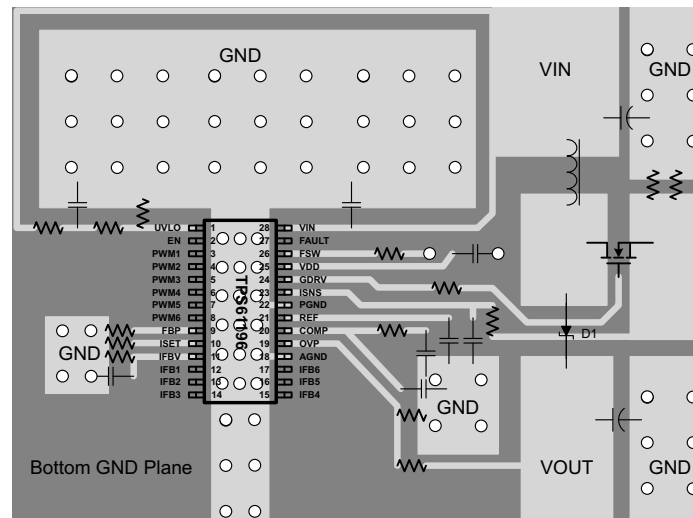

Figure 26. Layout Example

11 Device and Documentation Support

11.1 Trademarks

PowerPAD is a trademark of Texas Instruments.
All other trademarks are the property of their respective owners.

11.2 Electrostatic Discharge Caution



These devices have limited built-in ESD protection. The leads should be shorted together or the device placed in conductive foam during storage or handling to prevent electrostatic damage to the MOS gates.

11.3 Glossary

[SLYZ022](#) — *TI Glossary*.

This glossary lists and explains terms, acronyms, and definitions.

12 Mechanical, Packaging, and Orderable Information

The following pages include mechanical, packaging, and orderable information. This information is the most current data available for the designated devices. This data is subject to change without notice and revision of this document. For browser-based versions of this data sheet, refer to the left-hand navigation.

PACKAGING INFORMATION

Orderable Device	Status (1)	Package Type	Package Drawing	Pins	Package Qty	Eco Plan (2)	Lead/Ball Finish (6)	MSL Peak Temp (3)	Op Temp (°C)	Device Marking (4/5)	Samples
TPS61196PWPR	ACTIVE	HTSSOP	PWP	28	2000	Green (RoHS & no Sb/Br)	CU NIPDAU	Level-2-260C-1 YEAR	-40 to 85	TPS61196	Samples
TPS61196PWPT	ACTIVE	HTSSOP	PWP	28	250	Green (RoHS & no Sb/Br)	CU NIPDAU	Level-2-260C-1 YEAR	-40 to 85	TPS61196	Samples

(1) The marketing status values are defined as follows:

ACTIVE: Product device recommended for new designs.

LIFEBUY: TI has announced that the device will be discontinued, and a lifetime-buy period is in effect.

NRND: Not recommended for new designs. Device is in production to support existing customers, but TI does not recommend using this part in a new design.

PREVIEW: Device has been announced but is not in production. Samples may or may not be available.

OBsolete: TI has discontinued the production of the device.

(2) Eco Plan - The planned eco-friendly classification: Pb-Free (RoHS), Pb-Free (RoHS Exempt), or Green (RoHS & no Sb/Br) - please check <http://www.ti.com/productcontent> for the latest availability information and additional product content details.

TBD: The Pb-Free/Green conversion plan has not been defined.

Pb-Free (RoHS): TI's terms "Lead-Free" or "Pb-Free" mean semiconductor products that are compatible with the current RoHS requirements for all 6 substances, including the requirement that lead not exceed 0.1% by weight in homogeneous materials. Where designed to be soldered at high temperatures, TI Pb-Free products are suitable for use in specified lead-free processes.

Pb-Free (RoHS Exempt): This component has a RoHS exemption for either 1) lead-based flip-chip solder bumps used between the die and package, or 2) lead-based die adhesive used between the die and leadframe. The component is otherwise considered Pb-Free (RoHS compatible) as defined above.

Green (RoHS & no Sb/Br): TI defines "Green" to mean Pb-Free (RoHS compatible), and free of Bromine (Br) and Antimony (Sb) based flame retardants (Br or Sb do not exceed 0.1% by weight in homogeneous material)

(3) MSL, Peak Temp. - The Moisture Sensitivity Level rating according to the JEDEC industry standard classifications, and peak solder temperature.

(4) There may be additional marking, which relates to the logo, the lot trace code information, or the environmental category on the device.

(5) Multiple Device Markings will be inside parentheses. Only one Device Marking contained in parentheses and separated by a "~" will appear on a device. If a line is indented then it is a continuation of the previous line and the two combined represent the entire Device Marking for that device.

(6) Lead/Ball Finish - Orderable Devices may have multiple material finish options. Finish options are separated by a vertical ruled line. Lead/Ball Finish values may wrap to two lines if the finish value exceeds the maximum column width.

Important Information and Disclaimer: The information provided on this page represents TI's knowledge and belief as of the date that it is provided. TI bases its knowledge and belief on information provided by third parties, and makes no representation or warranty as to the accuracy of such information. Efforts are underway to better integrate information from third parties. TI has taken and continues to take reasonable steps to provide representative and accurate information but may not have conducted destructive testing or chemical analysis on incoming materials and chemicals. TI and TI suppliers consider certain information to be proprietary, and thus CAS numbers and other limited information may not be available for release.

In no event shall TI's liability arising out of such information exceed the total purchase price of the TI part(s) at issue in this document sold by TI to Customer on an annual basis.

TAPE AND REEL INFORMATION



QUADRANT ASSIGNMENTS FOR PIN 1 ORIENTATION IN TAPE



*All dimensions are nominal

Device	Package Type	Package Drawing	Pins	SPQ	Reel Diameter (mm)	Reel Width W1 (mm)	A0 (mm)	B0 (mm)	K0 (mm)	P1 (mm)	W (mm)	Pin1 Quadrant
TPS61196PWPR	HTSSOP	PWP	28	2000	330.0	16.4	6.9	10.2	1.8	12.0	16.0	Q1
TPS61196PWPT	HTSSOP	PWP	28	250	180.0	16.4	6.9	10.2	1.8	12.0	16.0	Q1

TAPE AND REEL BOX DIMENSIONS



*All dimensions are nominal

Device	Package Type	Package Drawing	Pins	SPQ	Length (mm)	Width (mm)	Height (mm)
TPS61196PWPR	HTSSOP	PWP	28	2000	367.0	367.0	38.0
TPS61196PWPT	HTSSOP	PWP	28	250	213.0	191.0	55.0

MECHANICAL DATA

PWP (R-PDSO-G28)

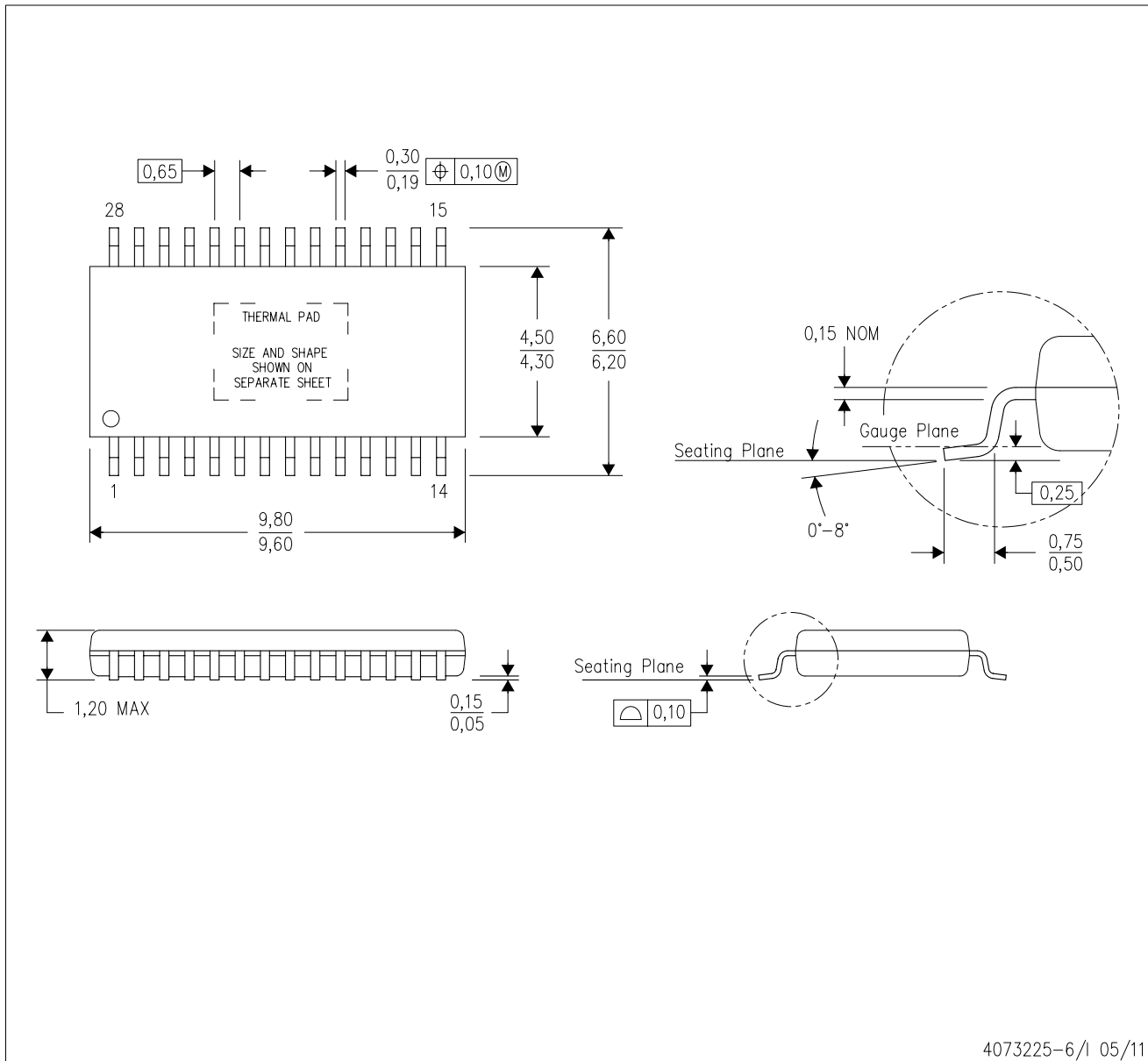
PowerPAD™ PLASTIC SMALL OUTLINE



- NOTES:
- All linear dimensions are in millimeters.
 - This drawing is subject to change without notice.
 - Body dimensions do not include mold flash or protrusions. Mold flash and protrusion shall not exceed 0.15 per side.
 - This package is designed to be soldered to a thermal pad on the board. Refer to Technical Brief, PowerPad Thermally Enhanced Package, Texas Instruments Literature No. SLMA002 for information regarding recommended board layout. This document is available at www.ti.com <<http://www.ti.com>>.
 - See the additional figure in the Product Data Sheet for details regarding the exposed thermal pad features and dimensions.
 - Falls within JEDEC MO-153

PowerPAD is a trademark of Texas Instruments.

THERMAL PAD MECHANICAL DATA

PWP (R-PDSO-G28) PowerPAD™ SMALL PLASTIC OUTLINE

THERMAL INFORMATION

This PowerPAD™ package incorporates an exposed thermal pad that is designed to be attached to a printed circuit board (PCB). The thermal pad must be soldered directly to the PCB. After soldering, the PCB can be used as a heatsink. In addition, through the use of thermal vias, the thermal pad can be attached directly to the appropriate copper plane shown in the electrical schematic for the device, or alternatively, can be attached to a special heatsink structure designed into the PCB. This design optimizes the heat transfer from the integrated circuit (IC).

For additional information on the PowerPAD package and how to take advantage of its heat dissipating abilities, refer to Technical Brief, PowerPAD Thermally Enhanced Package, Texas Instruments Literature No. SLMA002 and Application Brief, PowerPAD Made Easy, Texas Instruments Literature No. SLMA004. Both documents are available at www.ti.com.

The exposed thermal pad dimensions for this package are shown in the following illustration.

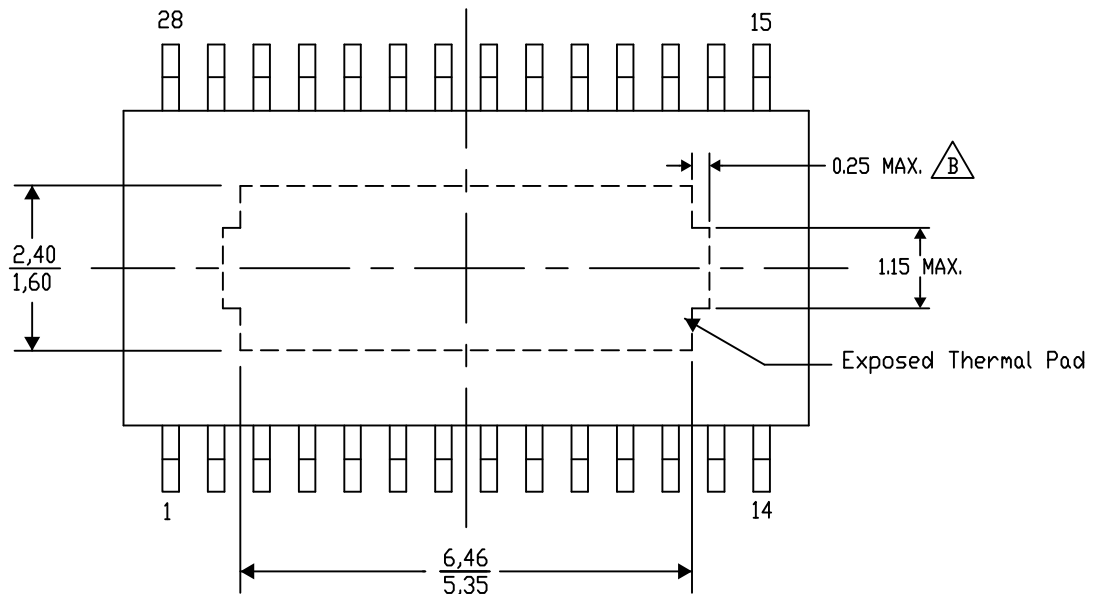

Top View

Exposed Thermal Pad Dimensions

4206332-34/AL 05/15

NOTE: A. All linear dimensions are in millimeters

$\triangle B$. Exposed tie strap features may not be present.

PowerPAD is a trademark of Texas Instruments

PWP (R-PDSO-G28)

PowerPAD™ PLASTIC SMALL OUTLINE

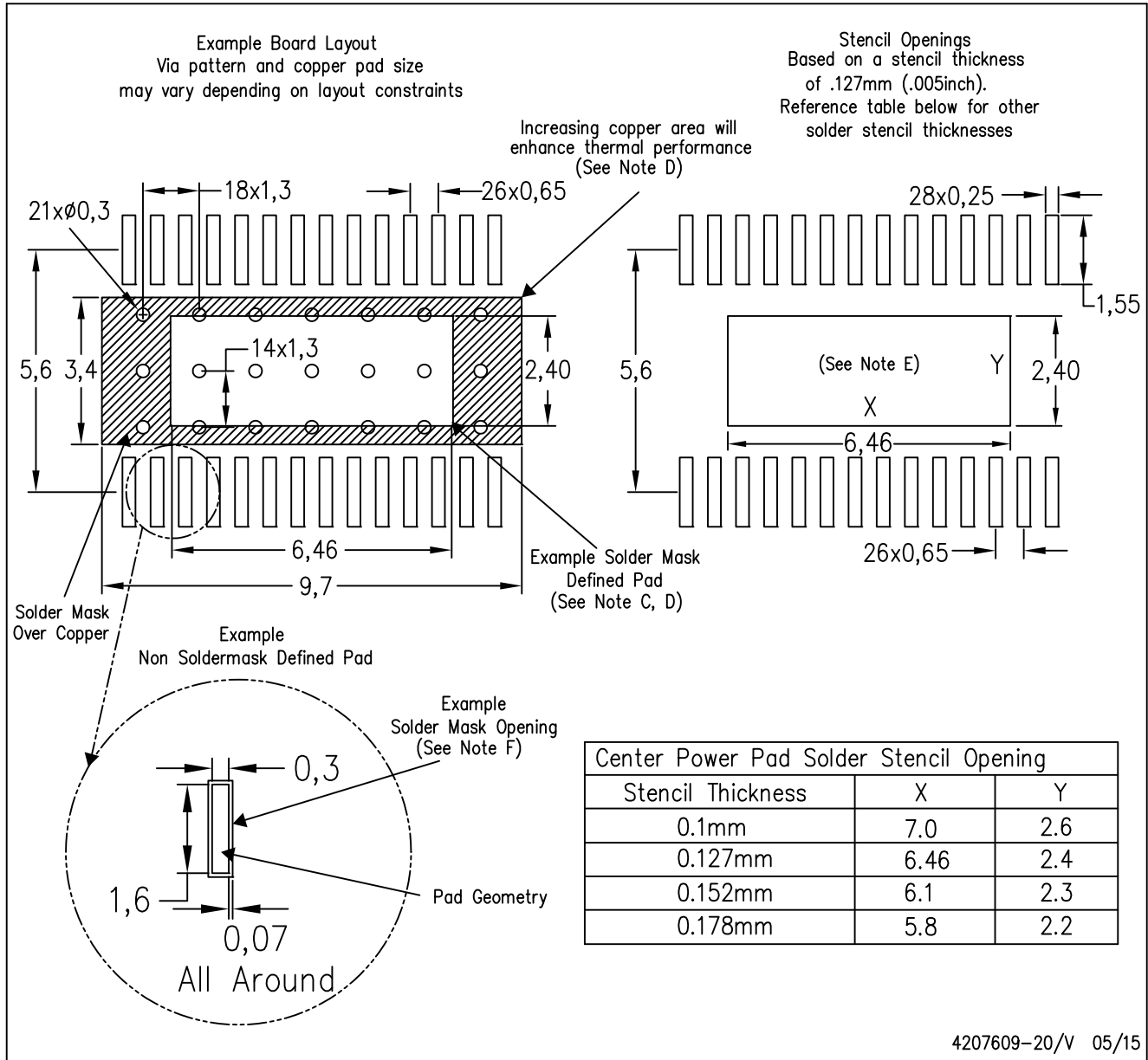

- NOTES:
- A. All linear dimensions are in millimeters.
 - B. This drawing is subject to change without notice.
 - C. Customers should place a note on the circuit board fabrication drawing not to alter the center solder mask defined pad.
 - D. This package is designed to be soldered to a thermal pad on the board. Refer to Technical Brief, PowerPad Thermally Enhanced Package, Texas Instruments Literature No. SLMA002, SLMA004, and also the Product Data Sheets for specific thermal information, via requirements, and recommended board layout. These documents are available at www.ti.com <<http://www.ti.com>>. Publication IPC-7351 is recommended for alternate designs.
 - E. Laser cutting apertures with trapezoidal walls and also rounding corners will offer better paste release. Customers should contact their board assembly site for stencil design recommendations. Example stencil design based on a 50% volumetric metal load solder paste. Refer to IPC-7525 for other stencil recommendations.
 - F. Customers should contact their board fabrication site for solder mask tolerances between and around signal pads.

IMPORTANT NOTICE

Texas Instruments Incorporated and its subsidiaries (TI) reserve the right to make corrections, enhancements, improvements and other changes to its semiconductor products and services per JESD46, latest issue, and to discontinue any product or service per JESD48, latest issue. Buyers should obtain the latest relevant information before placing orders and should verify that such information is current and complete. All semiconductor products (also referred to herein as "components") are sold subject to TI's terms and conditions of sale supplied at the time of order acknowledgment.

TI warrants performance of its components to the specifications applicable at the time of sale, in accordance with the warranty in TI's terms and conditions of sale of semiconductor products. Testing and other quality control techniques are used to the extent TI deems necessary to support this warranty. Except where mandated by applicable law, testing of all parameters of each component is not necessarily performed.

TI assumes no liability for applications assistance or the design of Buyers' products. Buyers are responsible for their products and applications using TI components. To minimize the risks associated with Buyers' products and applications, Buyers should provide adequate design and operating safeguards.

TI does not warrant or represent that any license, either express or implied, is granted under any patent right, copyright, mask work right, or other intellectual property right relating to any combination, machine, or process in which TI components or services are used. Information published by TI regarding third-party products or services does not constitute a license to use such products or services or a warranty or endorsement thereof. Use of such information may require a license from a third party under the patents or other intellectual property of the third party, or a license from TI under the patents or other intellectual property of TI.

Reproduction of significant portions of TI information in TI data books or data sheets is permissible only if reproduction is without alteration and is accompanied by all associated warranties, conditions, limitations, and notices. TI is not responsible or liable for such altered documentation. Information of third parties may be subject to additional restrictions.

Resale of TI components or services with statements different from or beyond the parameters stated by TI for that component or service voids all express and any implied warranties for the associated TI component or service and is an unfair and deceptive business practice. TI is not responsible or liable for any such statements.

Buyer acknowledges and agrees that it is solely responsible for compliance with all legal, regulatory and safety-related requirements concerning its products, and any use of TI components in its applications, notwithstanding any applications-related information or support that may be provided by TI. Buyer represents and agrees that it has all the necessary expertise to create and implement safeguards which anticipate dangerous consequences of failures, monitor failures and their consequences, lessen the likelihood of failures that might cause harm and take appropriate remedial actions. Buyer will fully indemnify TI and its representatives against any damages arising out of the use of any TI components in safety-critical applications.

In some cases, TI components may be promoted specifically to facilitate safety-related applications. With such components, TI's goal is to help enable customers to design and create their own end-product solutions that meet applicable functional safety standards and requirements. Nonetheless, such components are subject to these terms.

No TI components are authorized for use in FDA Class III (or similar life-critical medical equipment) unless authorized officers of the parties have executed a special agreement specifically governing such use.

Only those TI components which TI has specifically designated as military grade or "enhanced plastic" are designed and intended for use in military/aerospace applications or environments. Buyer acknowledges and agrees that any military or aerospace use of TI components which have **not** been so designated is solely at the Buyer's risk, and that Buyer is solely responsible for compliance with all legal and regulatory requirements in connection with such use.

TI has specifically designated certain components as meeting ISO/TS16949 requirements, mainly for automotive use. In any case of use of non-designated products, TI will not be responsible for any failure to meet ISO/TS16949.

Products

Audio	www.ti.com/audio
Amplifiers	amplifier.ti.com
Data Converters	dataconverter.ti.com
DLP® Products	www.dlp.com
DSP	dsp.ti.com
Clocks and Timers	www.ti.com/clocks
Interface	interface.ti.com
Logic	logic.ti.com
Power Mgmt	power.ti.com
Microcontrollers	microcontroller.ti.com
RFID	www.ti-rfid.com
OMAP Applications Processors	www.ti.com/omap
Wireless Connectivity	www.ti.com/wirelessconnectivity

Applications

Automotive and Transportation	www.ti.com/automotive
Communications and Telecom	www.ti.com/communications
Computers and Peripherals	www.ti.com/computers
Consumer Electronics	www.ti.com/consumer-apps
Energy and Lighting	www.ti.com/energy
Industrial	www.ti.com/industrial
Medical	www.ti.com/medical
Security	www.ti.com/security
Space, Avionics and Defense	www.ti.com/space-avionics-defense
Video and Imaging	www.ti.com/video

TI E2E Community

e2e.ti.com