

3-A High-Efficient Synchronous Step-Down Converter with DCS-Control™

Check for Samples: [TPS62090-Q1](#)

FEATURES

- Qualified for Automotive Applications
- AEC-Q100 Qualified With the Following Results:
 - Device Temperature Grade 1: –40°C to 125°C Junction Operating Temperature Range
 - Device HBM ESD Classification Level H2
 - Device CDM ESD Classification Level C6
- 2.5- to 6-V Input Voltage Range
- DCS-Control™
- 95% Converter Efficiency
- Power Save Mode
- 20- μ A Operating Quiescent Current
- 100% Duty Cycle for Lowest Dropout
- 2.8-MHz and 1.4-MHz Typical Switching Frequency
- 0.8-V to V_{IN} Adjustable Output Voltage
- Fixed-Output Voltage Versions
- Output Discharge Function
- Adjustable Softstart
- Two-Level Short-Circuit Protection
- Output Voltage Tracking
- Wide Output Capacitance Selection
- Available in 3 mm \times 3 mm 16-pin QFN Package

APPLICATIONS

- Distributed Power Supplies
- Notebook, Netbook Computers
- Hard Disk Drivers
- Processor Supply
- Battery Powered Applications

DESCRIPTION

The TPS6209X-Q1 device family is a high frequency synchronous step down converter optimized for small solution size, high efficiency and suitable for battery powered applications. To maximize efficiency, the converter operates in PWM mode with a nominal switching frequency of 2.8 MHz/1.4 MHz and automatically enters Power Save Mode operation at light load currents. When used in distributed power supplies and point of load regulation, the device allows voltage tracking to other voltage rails and tolerates output capacitors ranging from 10 μ F up to 150 μ F and beyond. Using the DCS-Control topology the device achieves excellent load transient performance and accurate output voltage regulation.

The output voltage start-up ramp is controlled by the softstart pin, which allows operation as either a standalone power supply or in tracking configurations. Power sequencing is also possible by configuring the Enable and Power Good pins. In Power Save Mode, the device operates at typically 20 μ A quiescent current. Power Save Mode is entered automatically and seamlessly maintaining high efficiency over the entire load current range.

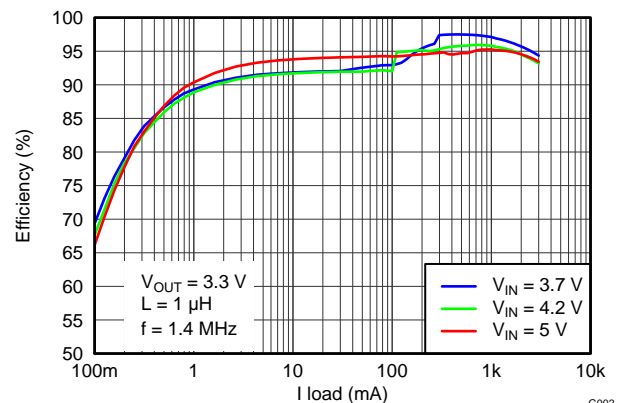
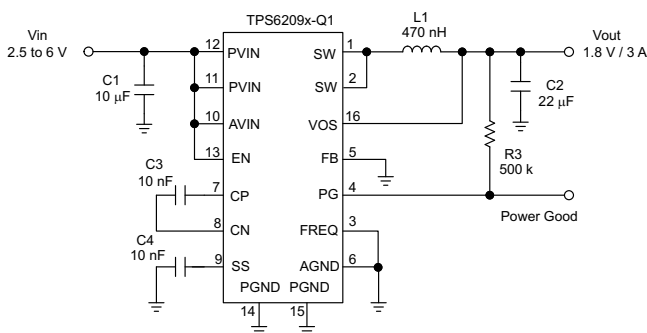

G002



Please be aware that an important notice concerning availability, standard warranty, and use in critical applications of Texas Instruments semiconductor products and disclaimers thereto appears at the end of this data sheet.

DCS-Control is a trademark of Texas Instruments.

All other trademarks are the property of their respective owners.



These devices have limited built-in ESD protection. The leads should be shorted together or the device placed in conductive foam during storage or handling to prevent electrostatic damage to the MOS gates.

ABSOLUTE MAXIMUM RATINGS⁽¹⁾

over operating free-air temperature range (unless otherwise noted)

		VALUE		UNIT
		MIN	MAX	
Voltage range	PVIN, AVIN, FB, SS, EN, FREQ, VOS ⁽²⁾	-0.3	7	V
	SW, PG	-0.3	V _{IN} + 0.3	V
Power Good sink current	PG		1	mA
ESD rating	Human Body Model (HBM)		2500	V
	Charged Device Model (CDM)		1500	V
Continuous total power dissipation		See the Thermal Table		
Operating junction temperature range, T _J		-40	150	°C
Storage temperature range, T _{stg}		-65	150	°C

- (1) Stresses beyond those listed under *absolute maximum ratings* may cause permanent damage to the device. These are stress ratings only and functional operation of the device at these or any other conditions beyond those indicated under *recommended operating conditions* is not implied. Exposure to absolute–maximum–rated conditions for extended periods may affect device reliability.
- (2) All voltage values are with respect to network ground terminal.

THERMAL INFORMATION

THERMAL METRIC ⁽¹⁾		TPS62090-Q1	UNITS
		QFN (16 PINS)	
θ _{JA}	Junction-to-ambient thermal resistance	45.6	°C/W
θ _{JCtop}	Junction-to-case (top) thermal resistance	58.9	
θ _{JB}	Junction-to-board thermal resistance	19	
ψ _{JT}	Junction-to-top characterization parameter	1.1	
ψ _{JB}	Junction-to-board characterization parameter	19	
θ _{JCbot}	Junction-to-case (bottom) thermal resistance	4.0	

- (1) For more information about traditional and new thermal metrics, see the *IC Package Thermal Metrics* application report, [SPRA953](#).

RECOMMENDED OPERATING CONDITIONS⁽¹⁾

		MIN	TYP	MAX	UNIT
V _{IN}	Input voltage range	2.5		6	V
T _J	Operating junction temperature	-40		125	°C

- (1) See the [APPLICATION INFORMATION](#) for further information

ELECTRICAL CHARACTERISTICS

 $V_{IN} = 3.6\text{ V}$, $T_J = -40^\circ\text{C}$ to 125°C , typical values are at $T_J = 25^\circ\text{C}$ (unless otherwise noted)

PARAMETER		TEST CONDITIONS	MIN	TYP	MAX	UNIT
SUPPLY						
V_{IN}	Input voltage range		2.5		6	V
I_{QIN}	Quiescent current	Not switching, FB = FB +5 %, Into PVIN and AVIN		20		μA
I_{sd}	Shutdown current	Into PVIN and AVIN		0.6	5	μA
UVLO	Undervoltage lockout threshold	V_{IN} falling	2.1	2.2	2.3	V
	Undervoltage lockout hysteresis			200		mV
	Thermal shutdown	Temperature rising		150		$^\circ\text{C}$
	Thermal shutdown hysteresis			20		$^\circ\text{C}$
Control SIGNALS EN, FREQ						
V_H	High level input voltage	$V_{IN} = 2.5$ to 6 V	1			V
V_L	Low level input voltage	$V_{IN} = 2.5$ to 6 V			0.4	V
I_{lkg}	Input leakage current	EN, FREQ = GND or V_{IN}		10	100	nA
R_{PD}	Pull down resistance			400		k Ω
Softstart						
I_{SS}	Softstart current		6.3	7.5	8.7	μA
POWER GOOD						
V_{th}	Power good threshold	Output voltage rising		95%		
		Output voltage falling		90%		
V_L	Low level voltage	$I_{(sink)} = 1\text{ mA}$			0.4	V
I_{PG}	PG sinking current				1	mA
I_{lkg}	Leakage current	$V_{PG} = 3.6\text{ V}$		10	200	nA
POWER SWITCH						
$R_{DS(on)}$	High side FET on-resistance	$I_{SW} = 500\text{ mA}$		50		m Ω
	Low side FET on-resistance	$I_{SW} = 500\text{ mA}$		40		m Ω
I_{LIM}	High side FET switch current limit		3.7	4.6	5.5	A
f_s	Switching frequency	FREQ = GND, $I_{OUT} = 3\text{ A}$		2.8		MHz
		FREQ = VIN, $I_{OUT} = 3\text{ A}$		1.4		MHz
OUTPUT						
V_s	Output voltage range		0.8		V_{IN}	V
R_{od}	Output discharge resistor	EN = GND, $V_{OUT} = 1.8\text{ V}$		200		Ω
V_{FB}	Feedback regulation voltage			0.8		V
V_{FB}	Feedback voltage accuracy ⁽¹⁾⁽²⁾⁽³⁾	$V_{IN} \geq V_{OUT} + 1\text{ V}$, TPS6209X-Q1 adjustable output version $I_{OUT} = 1\text{ A}$, PWM mode	-1.4%		+1.4%	
		$I_{OUT} = 0\text{ mA}$, FREQ = 2.8 MHz, $V_{OUT} \geq 0.8\text{ V}$, PFM mode	-1.4%		+3%	
		$I_{OUT} = 0\text{ mA}$, FREQ = 1.4 MHz, $V_{OUT} \geq 1.2\text{ V}$, PFM mode	-1.4%		+3%	
		$I_{OUT} = 0\text{ mA}$, FREQ = 1.4 MHz, $V_{OUT} < 1.2\text{ V}$, PFM mode	-1.4%		+3.7%	
I_{FB}	Feedback input bias current	$V_{FB} = 0.8\text{ V}$, TPS6209X-Q1 adjustable output version		10	100	nA
V_{OUT}	Output voltage accuracy ⁽²⁾⁽³⁾	$V_{IN} \geq V_{OUT} + 1\text{ V}$, Fixed output voltage $I_{OUT} = 1\text{ A}$, PWM mode	-1.4%		+1.4%	
		$I_{OUT} = 0\text{ mA}$, FREQ = High and Low, PFM mode	-1.4%		+2.5%	
	Line regulation	$V_{OUT} = 1.8\text{ V}$, PWM operation		0.016		%/V
	Load regulation	$V_{OUT} = 1.8\text{ V}$, PWM operation		0.04		%/A

(1) For output voltages < 1.2 V, use a $2 \times 22\text{ }\mu\text{F}$ output capacitance to achieve +3% output voltage accuracy.

(2) Conditions: $f = 2.8\text{ MHz}$, $L = 0.47\text{ }\mu\text{H}$, $C_{OUT} = 22\text{ }\mu\text{F}$ or $f = 1.4\text{ MHz}$, $L = 1\text{ }\mu\text{H}$, $C_{OUT} = 22\text{ }\mu\text{F}$.

(3) For more information, see the [Power Save Mode Operation](#) section of this data sheet.

DEVICE INFORMATION

16 PIN 3 mm × 3 mm QFN
TOP VIEW

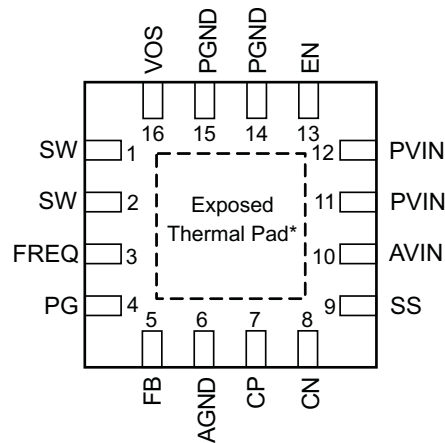

NOTE: *The exposed Thermal Pad is connected to AGND.

PIN FUNCTIONS

PIN		I/O	DESCRIPTION
NAME	NO.		
SW	1, 2	I	Switch pin of the power stage.
FREQ	3	I	This pin selects the switching frequency of the device. FREQ=low sets the typical switching frequency to 2.8 MHz. FREQ = high sets the typical switching frequency to 1.4 MHz. This pin has an active pulldown resistor of typically 400 k Ω and can be left floating for 2.8 MHz operation.
PG	4	O	Power good open drain output. This pin is high impedance if the output voltage is within regulation. This pin is pulled low if the output is below its nominal value. The pullup resistor can not be connected to any voltage higher than the input voltage of the device.
FB	5		Feedback pin of the device. For the fixed output voltage versions this pin must be connected to GND for improved thermal performance. If desired leave this pin floating because it is internally connected with 400 k Ω to GND for fixed output voltage versions.
AGND	6		Analog ground.
CP	7		Internal charge-pump flying capacitor. Connect a 10-nF capacitor between CP and CN.
CN	8		Internal charge-pump flying capacitor. Connect a 10-nF capacitor between CP and CN.
SS	9	I	Softstart control pin. A capacitor is connected to this pin and sets the softstart time. Leaving this pin floating sets the minimum start-up time.
AVIN	10		Bias-supply input-voltage pin.
PVIN	11,12		Power-supply input-voltage pin.
EN	13		Device enable. To enable the device this pin must be pulled high. Pulling this pin low disables the device. This pin has an active pulldown resistor of typically 400 k Ω .
PGND	14,15		Power ground connection.
VOS	16		Output-voltage sense pin. This pin must be connected to the output voltage.
Thermal Pad			The exposed thermal pad is connected to AGND.

FUNCTIONAL BLOCK DIAGRAM

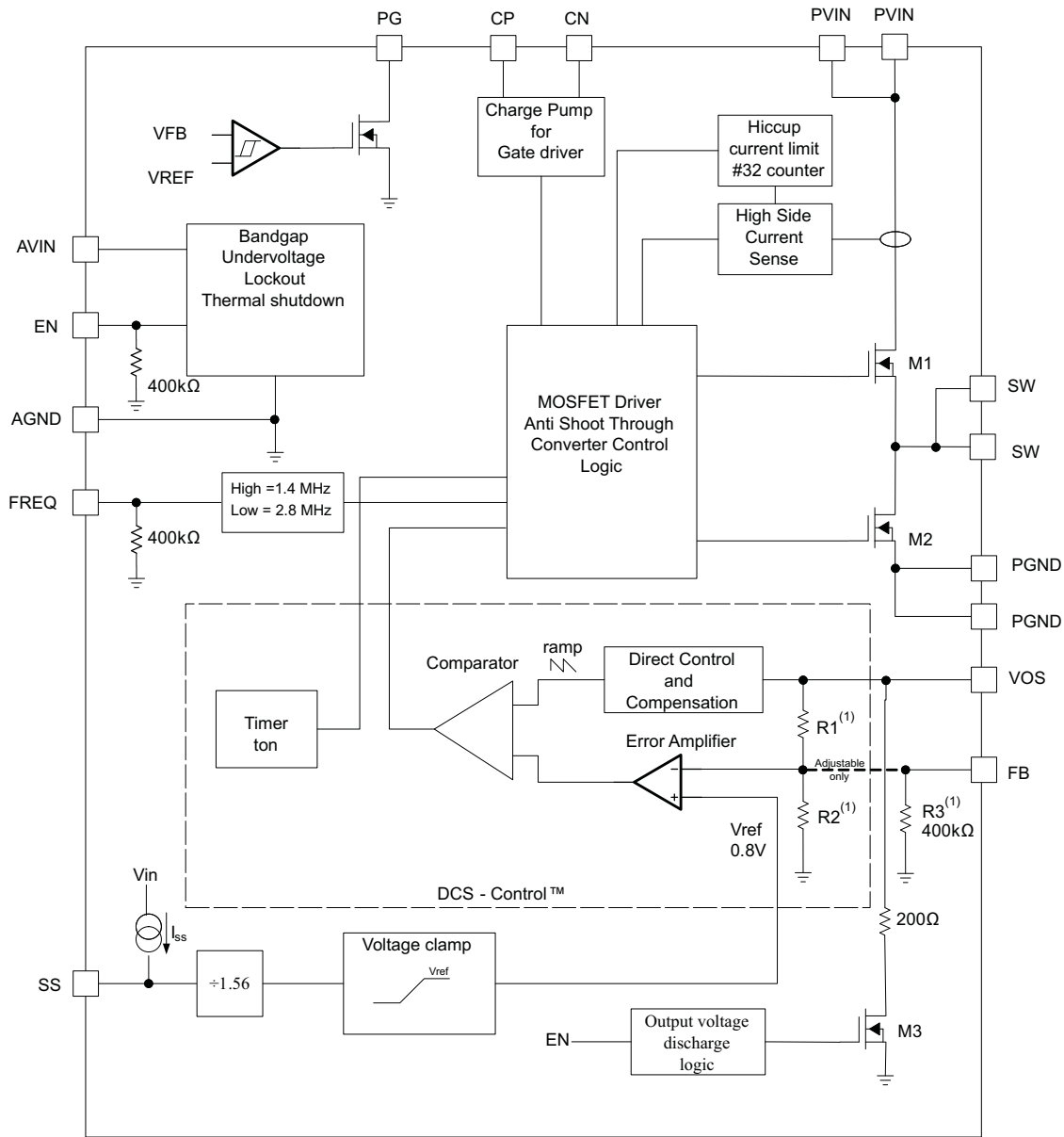

(1) R1, R2, R3 are implemented in the fixed output voltage version only.

Table 1. List of components

REFERENCE	DESCRIPTION	MANUFACTURER
TPS6209X-Q1	High efficient step down converter	Texas Instruments
L1	Inductor: 1 μ H, 0.47 μ H, 0.4 μ H	Coilcraft XFL4020-102, XAL4020-401, TOKO DEF252012-R47
C1	Ceramic capacitor: 10 μ F, 22 μ F	(6.3-V, X5R, 0603), (6.3-V, X5R, 0805)
C2	Ceramic capacitor: 22 μ F	(6.3-V, X5R, 0805)
C3, C4	Ceramic capacitor	Standard
R1, R2, R3	Resistor	Standard

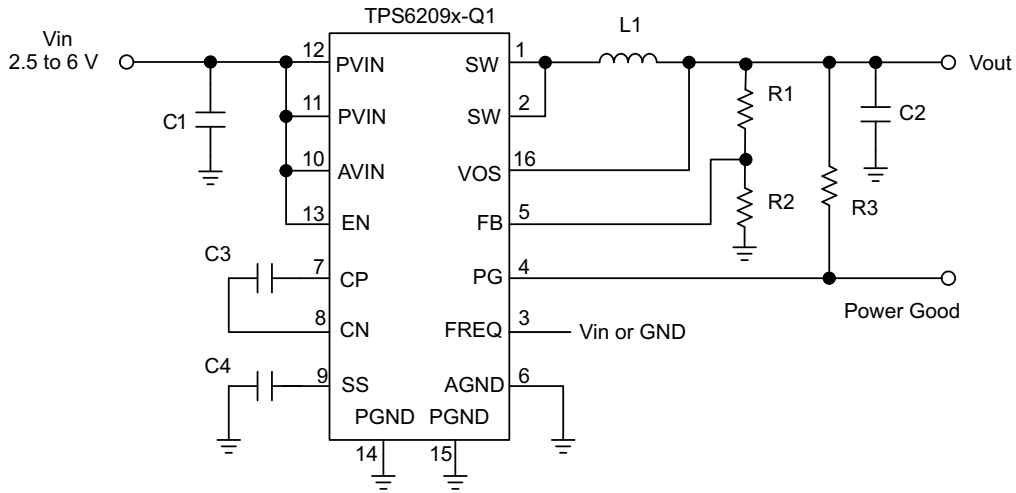

Figure 1. Parametric Measurement Circuit

TYPICAL CHARACTERISTICS

		FIGURE
Efficiency	vs load current ($V_O = 3.3\text{ V}$, $f = 1.4\text{ MHz}$, $f = 2.8\text{ MHz}$)	Figure 2, Figure 3
Efficiency	vs load current ($V_O = 1.8\text{ V}$, $f = 1.4\text{ MHz}$, $f = 2.8\text{ MHz}$)	Figure 4, Figure 5
Efficiency	vs load current ($V_O = 1.05\text{ V}$, $f = 1.4\text{ MHz}$, $f = 2.8\text{ MHz}$)	Figure 6, Figure 7
Output voltage	vs load current ($V_O = 1.8\text{ V}$, $f = 1.4\text{ MHz}$, $f = 2.8\text{ MHz}$)	Figure 8, Figure 9
High Side FET on-resistance	vs input voltage	Figure 10
Switching frequency	vs load current ($V_O = 1.8\text{ V}$, $f = 1.4\text{ MHz}$)	Figure 11
Switching frequency	vs input voltage ($V_O = 1.8\text{ V}$, $f = 1.4\text{ MHz}$)	Figure 12
Switching frequency	vs load current ($V_O = 1.8\text{ V}$, $f = 2.8\text{ MHz}$)	Figure 13
Switching frequency	vs input voltage ($V_O = 1.8\text{ V}$, $f = 2.8\text{ MHz}$)	Figure 14
Quiescent current	vs input voltage ($V_O = 1.8\text{ V}$, $f = 1.4\text{ MHz}$)	Figure 15
PWM operation	$V_O = 1.8\text{ V}$, $f = 1.4\text{ MHz}$	Figure 16
PFM operation	$V_O = 1.8\text{ V}$, $f = 1.4\text{ MHz}$	Figure 17
PFM operation	$V_O = 1.8\text{ V}$, $f = 2.8\text{ MHz}$	Figure 18
Load sweep	$V_O = 1.8\text{ V}$, $f = 1.4\text{ MHz}$	Figure 19
Load sweep	$V_O = 1.8\text{ V}$, $f = 2.8\text{ MHz}$	Figure 20
Start-up	$V_O = 1.8\text{ V}$, $f = 2.8\text{ MHz}$, $C_{SS} = 10\text{ nF}$	Figure 21
Shutdown	$V_O = 1.8\text{ V}$, $f = 2.8\text{ MHz}$	Figure 22
Hiccup short circuit protection	$V_O = 1.8\text{ V}$, $f = 1.4\text{ MHz}$	Figure 23
Hiccup Short circuit protection	$V_O = 1.8\text{ V}$, $f = 1.4\text{ MHz}$, recovery after short circuit	Figure 24
Load transient response	$V_O = 1.8\text{ V}$, $f = 1.4\text{ MHz}$, 300 mA to 2.5 A	Figure 25
Load transient response	$V_O = 1.8\text{ V}$, $f = 1.4\text{ MHz}$, 300 mA to 2.5 A	Figure 26
Load transient response	$V_O = 1.8\text{ V}$, $f = 1.4\text{ MHz}$, 20 mA to 1 A	Figure 27

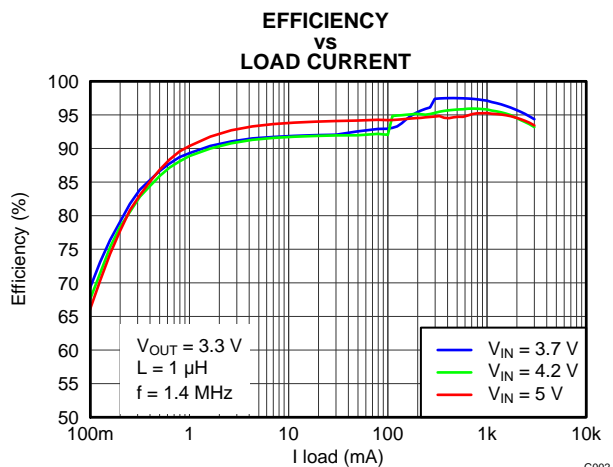

Figure 2.

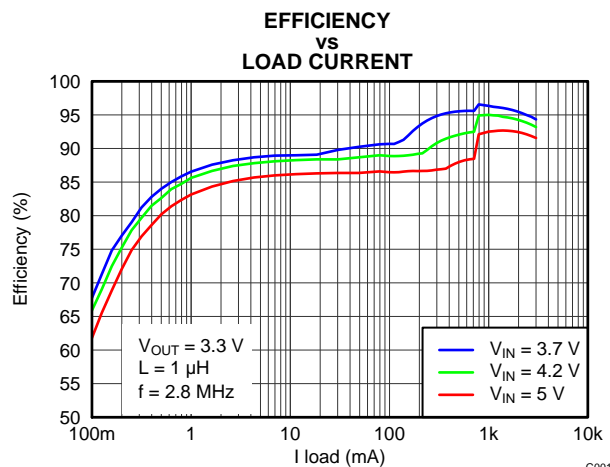

Figure 3.

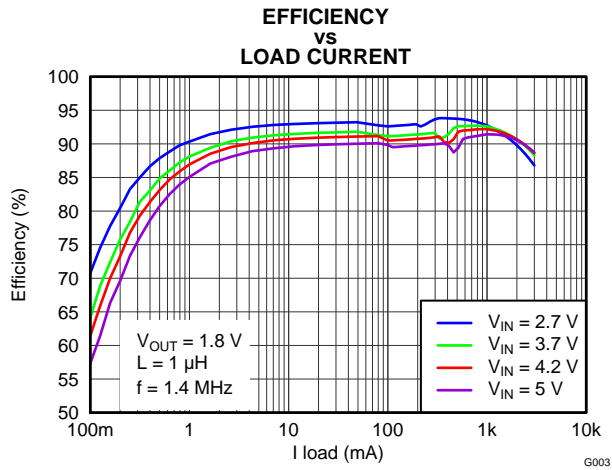

Figure 4.

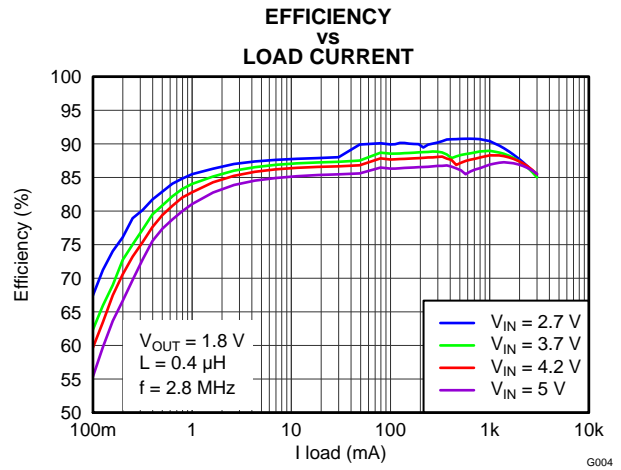

Figure 5.

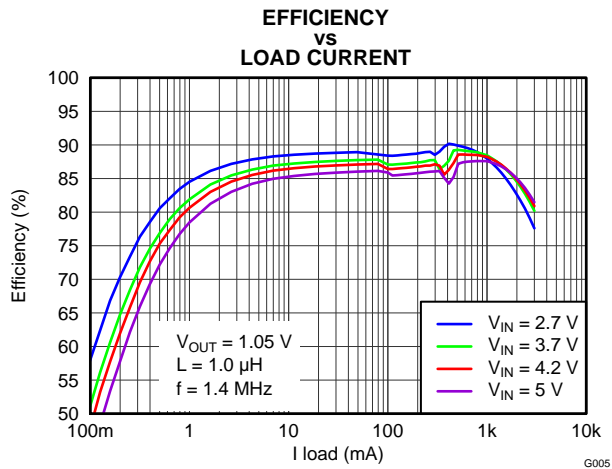

Figure 6.

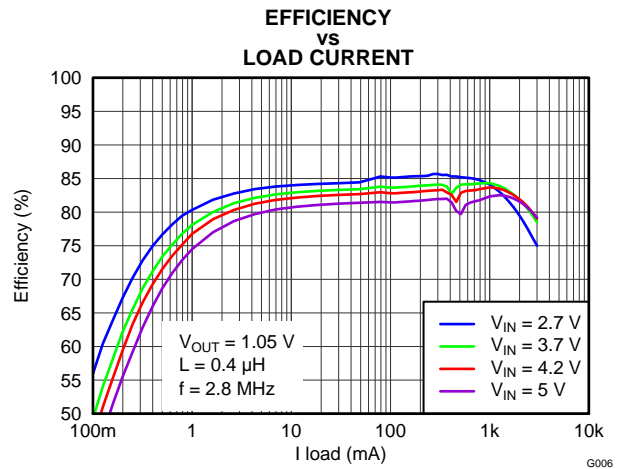

Figure 7.

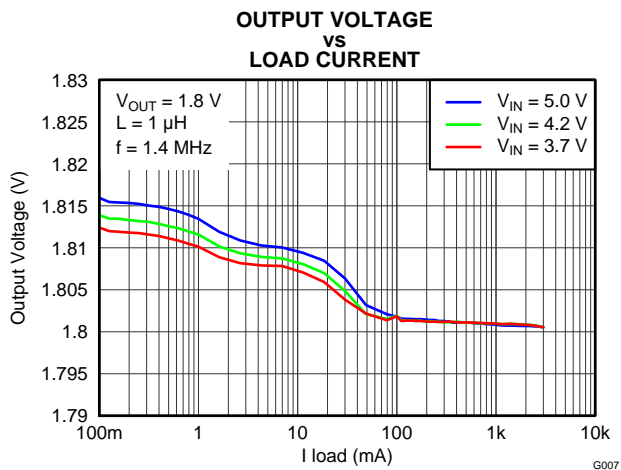

Figure 8.

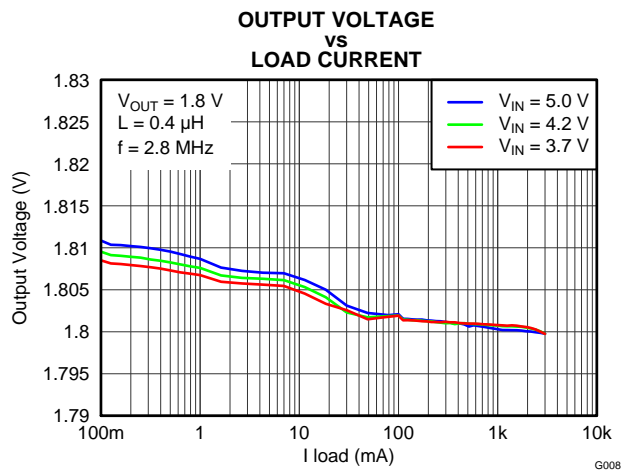
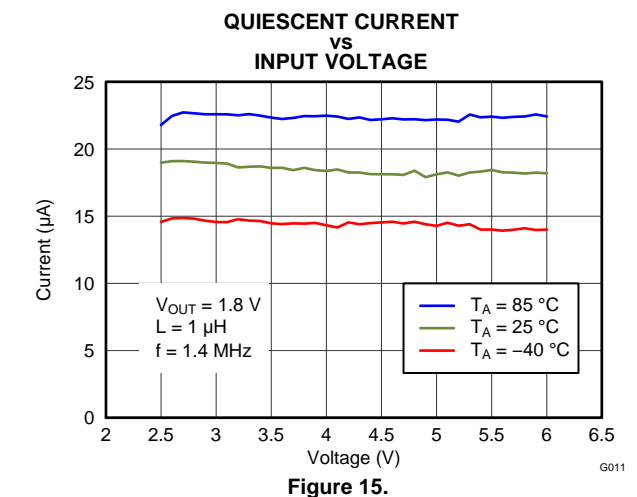
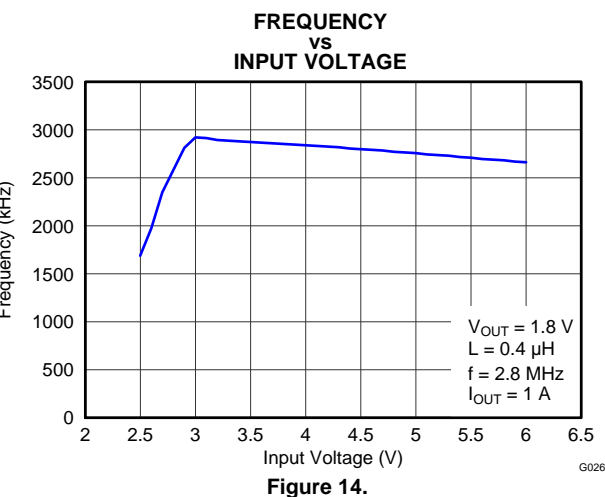
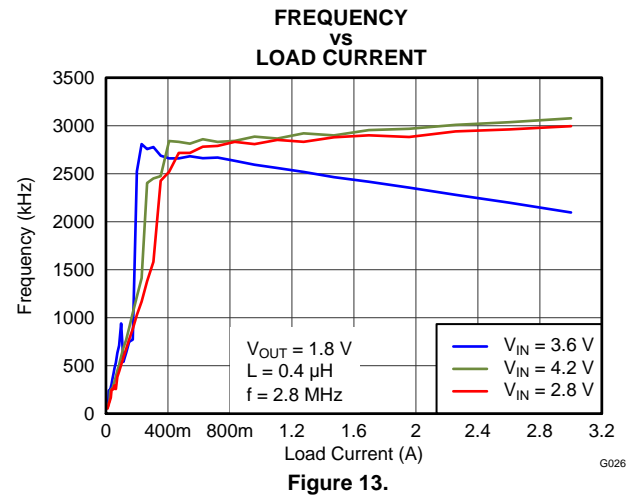
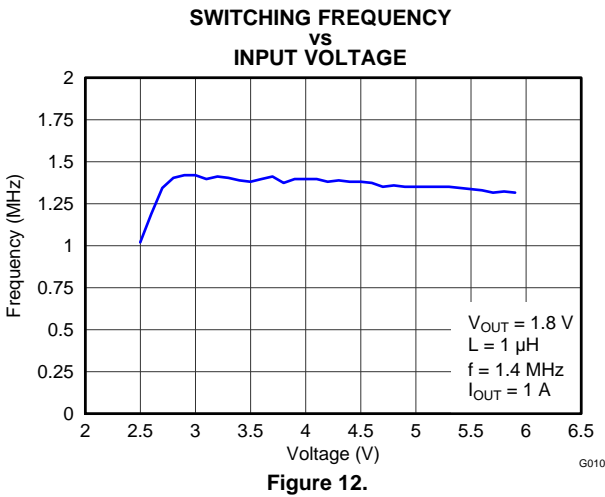
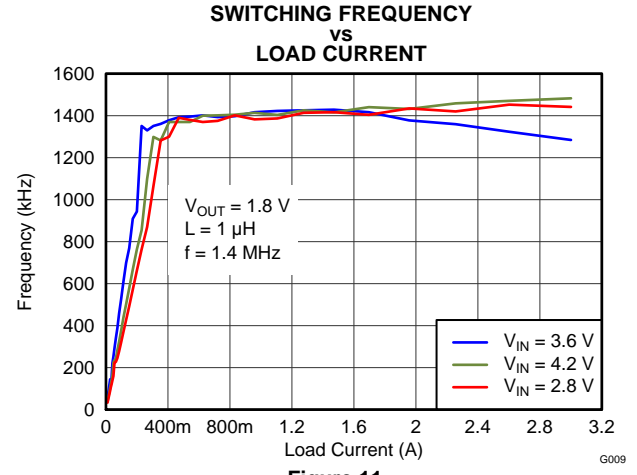
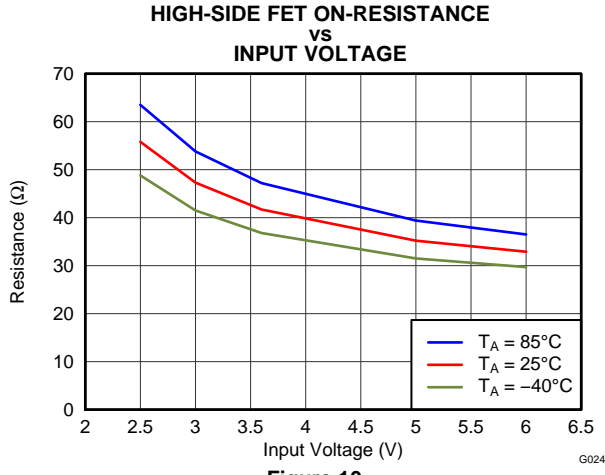

Figure 9.



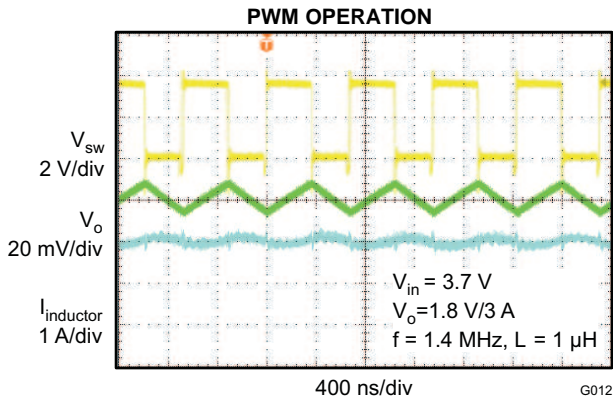

Figure 16.

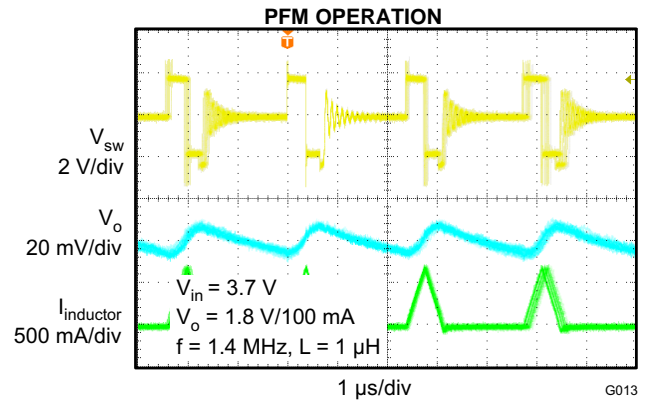

Figure 17.

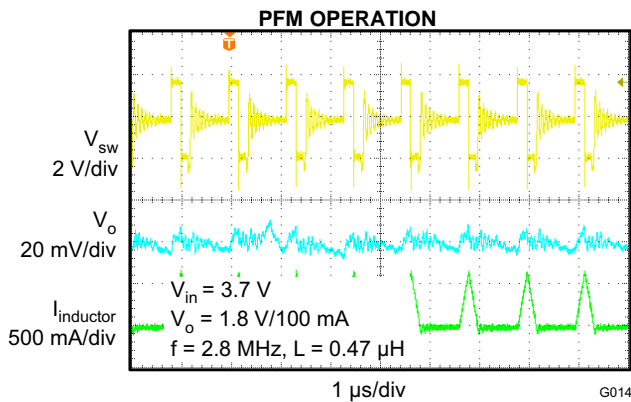

Figure 18.

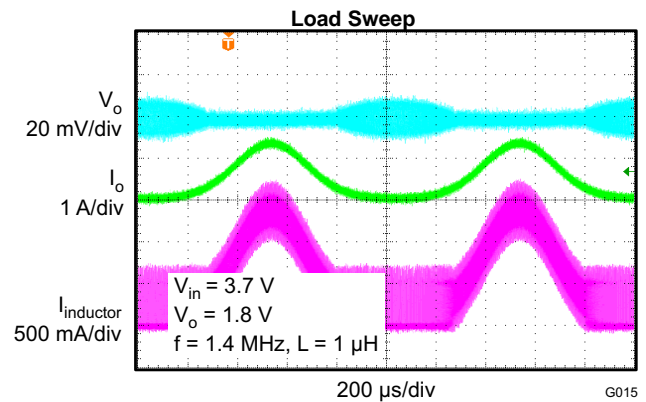

Figure 19.

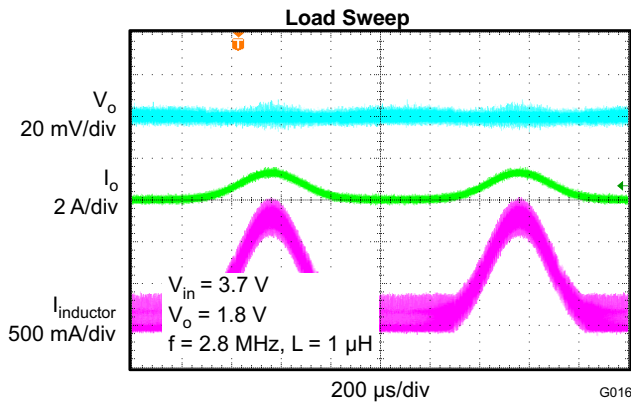

Figure 20.

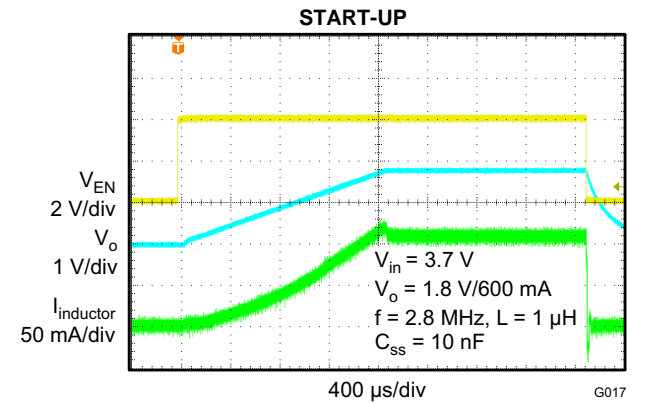

Figure 21.

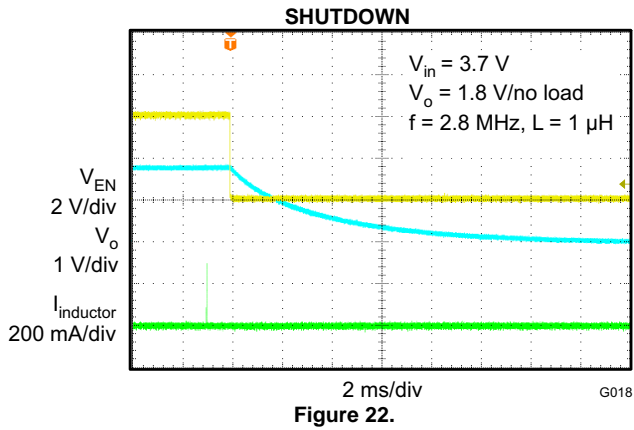

Figure 22.

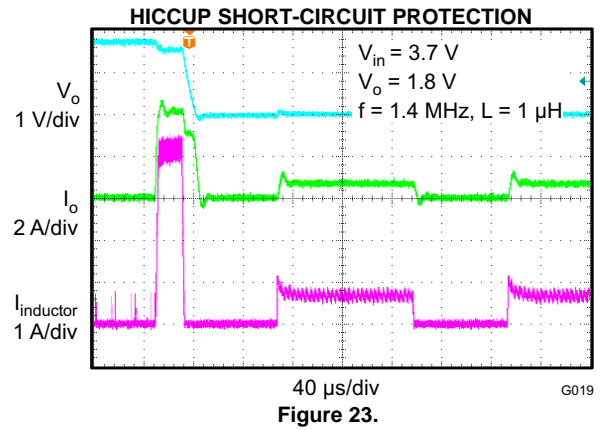

Figure 23.

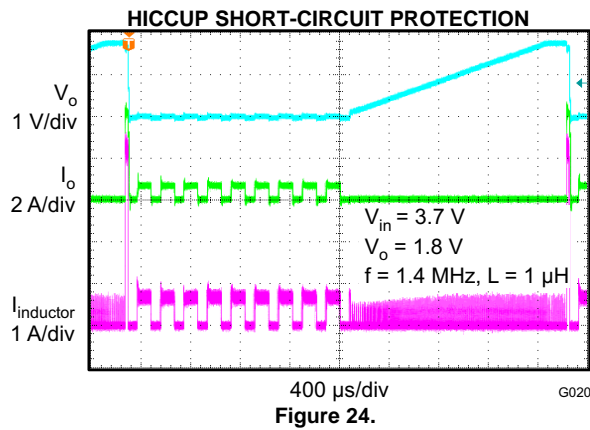

Figure 24.

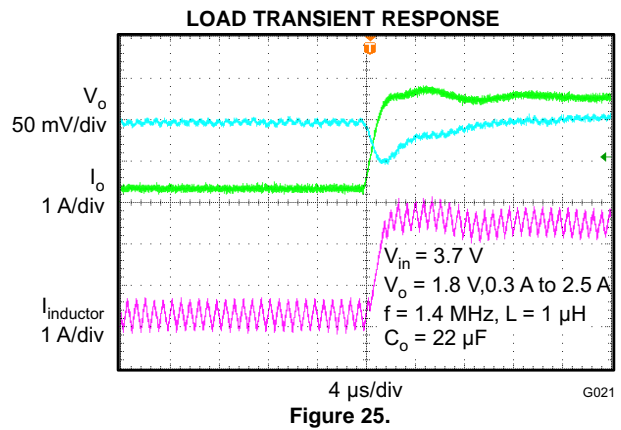

Figure 25.

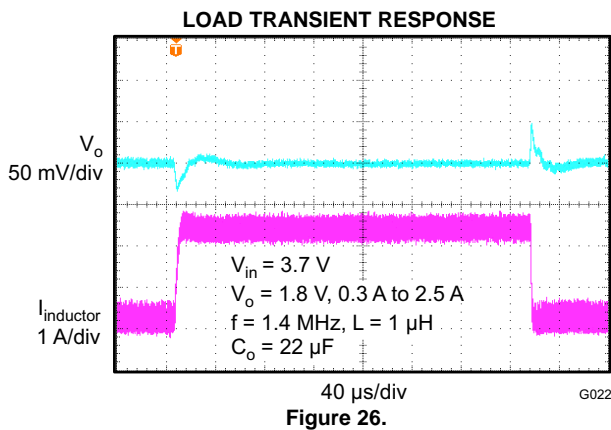

Figure 26.

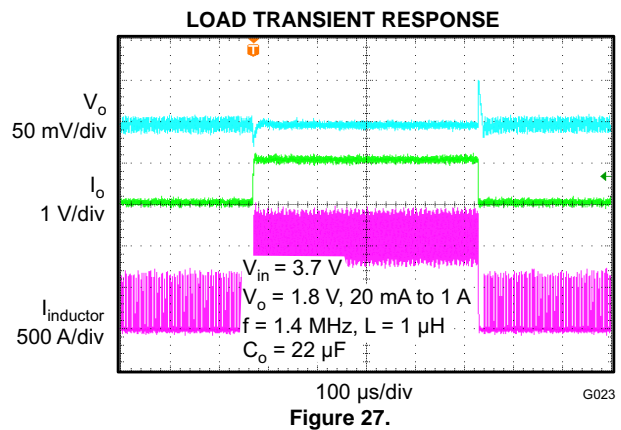

Figure 27.

DETAILED DESCRIPTION

Operation

The TPS6209X-Q1 synchronous switched mode converters are based on DCS-Control (Direct Control with Seamless transition into Power Save Mode). DCS-Control is an advanced regulation topology that combines the advantages of hysteretic and voltage mode control.

The DCS-Control topology operates in Pulse Width Modulation (PWM) mode for medium to heavy load conditions and in Power Save Mode at light load currents. In PWM, the converter operates with nominal switching frequency of 2.8 MHz or 1.4 MHz, having a controlled frequency variation over the input voltage range. As the load current decreases, the converter enters Power Save Mode, reducing the switching frequency and minimizing the IC quiescent current to achieve high efficiency over the entire load current range. DCS-Control supports both operation modes (PWM and PFM) using a single building block with a seamless transition from PWM to Power Save Mode without effecting the output voltage. Fixed-output voltage versions provide the smallest solution size combined with lowest quiescent current. The TPS6209X-Q1 family offers excellent DC-voltage regulation and load transient regulation, combined with low output voltage ripple, to minimize interference with RF circuits.

PWM Operation

At medium to heavy load currents, the device operates with PWM at a nominal switching frequency of 2.8 MHz or 1.4 MHz depending on the setting of the **FREQ** pin. As the load current decreases, the converter enters the Power Save Mode operation reducing the switching frequency. The device enters Power Save Mode at the boundary to discontinuous conduction mode (DCM).

Power Save Mode Operation

As the load current decreases, the converter enters Power Save Mode operation. During Power Save Mode the converter operates with reduced switching frequency in PFM mode and with a minimum quiescent current while maintaining high efficiency. The Power Save Mode is based on a fixed on-time architecture following [Equation 1](#). When operating at 1.4 MHz, the on-time is twice as long as the on-time for 2.8 MHz operation, resulting in larger output voltage ripple, as shown in [Figure 17](#) and [Figure 18](#), and slightly higher output voltage at no load, as shown in [Figure 8](#) and [Figure 9](#). To have the same output voltage ripple at 1.4 MHz during PFM mode, either the output capacitor or the inductor value must be increased. As an example, operating at 2.8 MHz using 0.47-μH inductor gives the same output voltage ripple as operating with 1.4 MHz using 1-μH inductor.

$$\begin{aligned}
 t_{on_{2.8\text{MHz}}} &= \frac{V_{OUT}}{V_{IN}} \times 360\text{ns} \\
 t_{on_{1.4\text{MHz}}} &= \frac{V_{OUT}}{V_{IN}} \times 360\text{ns} \times 2 \\
 f &= \frac{2 \times I_{OUT}}{t_{on}^2 \left(1 + \frac{V_{IN} - V_{OUT}}{V_{OUT}} \right) \times \frac{V_{IN} - V_{OUT}}{L}}
 \end{aligned} \tag{1}$$

In Power Save Mode the output voltage rises slightly above the nominal output voltage in PWM mode, as shown in [Figure 8](#) and [Figure 9](#). This effect is reduced by increasing the output capacitance or the inductor value. This effect is also reduced by programming the output voltage of the TPS6209X-Q1 lower than the target value. As an example, if the target output voltage is 3.3 V, then the TPS6209X-Q1 is programmed to 3.3 V – 0.8%. As a result the output voltage accuracy is now –2.2% to +2.2% instead of –1.4% to 3%. The output voltage accuracy in PFM operation is reflected in the [ELECTRICAL CHARACTERISTICS](#) table and given for a 22-μF output capacitance.

Low Dropout Operation (100% Duty Cycle)

The device offers low input to output voltage difference by entering 100% duty cycle mode. In this mode the high-side MOSFET switch is constantly turned on which is particularly useful in battery powered applications to achieve longest operation time by taking full advantage of the whole battery voltage range. The minimum input voltage where the output voltage falls below the nominal regulation value is given by [Equation 2](#).

$$V_{IN(min)} = V_{OUT(max)} + I_{OUT} \times (R_{DS(on)} + R_L)$$

Where

- $R_{DS(on)}$ = High side FET on-resistance
- R_L = DC resistance of the inductor
- $V_{OUT(max)}$ = nominal output voltage plus maximum output-voltage tolerance

Softstart (SS)

To minimize inrush current during start-up, the device has an adjustable softstart depending on the capacitor value connected to the SS pin. The device charges the softstart capacitor with a constant current of typically 7.5 μ A. The feedback voltage follows this voltage with a fraction of 1.56 until the internal reference voltage of 0.8 V is reached. The softstart operation is complete when the voltage at the softstart capacitor has reached typically 1.25 V. The soft-start time is calculated using [Equation 3](#). The larger the softstart capacitor, the longer the softstart time. The relation between softstart voltage and feedback voltage is estimated using [Equation 4](#).

$$t_{SS} = C_{SS} \times \frac{1.25V}{7.5\mu A}$$

$$V_{FB} = \frac{V_{SS}}{1.56}$$

[Equation 4](#) is also the case for the fixed output voltage option having the internal regulation voltage. Leaving the softstart pin floating sets the minimum start-up time.

Start-up Tracking (SS)

The softstart pin also implements output voltage tracking with other supply rails. The internal reference voltage follows the voltage at the softstart pin with a fraction of 1.56 until the internal reference voltage of 0.8 V is reached. The softstart pin implements output voltage tracking as shown in [Figure 28](#).

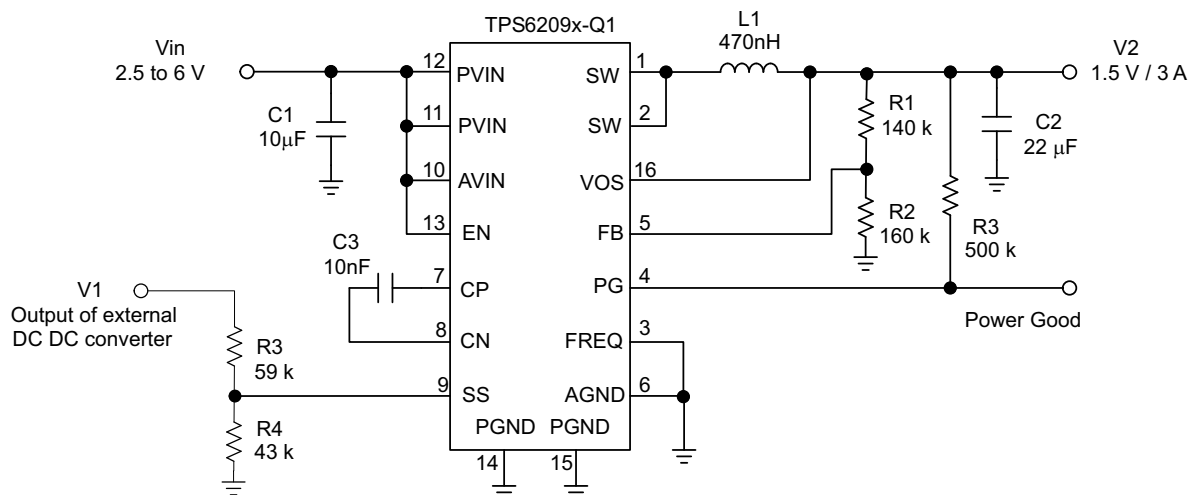

Figure 28. Output Voltage Tracking

In [Figure 28](#), the output V2 tracks the voltage applied to V1. The voltage tracks simultaneously when the conditions in [Equation 5](#) are met.

$$\frac{R3}{R4} = \frac{R1}{R2} \times 1.56$$

As the fraction of R3/R4 becomes larger the voltage V1 ramps up faster than V2 and if the fraction becomes smaller then the ramp is slower than V2. R4 must be determined first using [Equation 6](#).

$$R4 = \frac{1.25V}{300\mu A} \quad (6)$$

In the calculation of R4, 300- μ A current is used to achieve sufficient accuracy by taking into account the typical 7.5- μ A soft-start current. After determining R4, R3 is calculated using [Equation 5](#).

Short Circuit Protection (Hiccup-Mode)

The device is protected against hard short circuits to GND and overcurrent events. This protection is implemented by a two-level short-circuit protection. During start-up and when the output is shorted to GND the switch current limit is reduced to 1/3 of the typical current limit of 4.6 A. When the output voltage exceeds typically 0.6 V, the current limit is released to the nominal value. The full current limit is implemented as a hiccup current limit. Once the internal current limits are triggered 32 times, the device stops switching and starts a new start-up sequence after a typical delay time of 66 μ S passed by. The device continues in this cycle until the high current condition is released.

Output Discharge Function

To ensure the device starts up under the defined conditions, the output discharges through the VOS pin with a typical discharge resistor of 200 Ω whenever the device shuts down. This discharge happens when the device is disabled or if thermal shutdown, undervoltage lockout or short circuit hiccup-mode is triggered.

Power Good Output (PG)

The power good output is low when the output voltage is below the nominal value. The power good becomes high impedance once the output is within 5% of regulation. The PG pin is an open drain output and is specified to typically sink up to 1 mA. This output requires a pullup resistor to be monitored properly. The pullup resistor cannot be connected to any voltage higher than the input voltage of the device.

Frequency Set Pin (FREQ)

The FREQ pin is a digital logic input which sets the nominal switching frequency. Pulling this pin to GND sets the nominal switching frequency to 2.8 MHz and pulling this pin high sets the nominal switching frequency to 1.4 MHz. Because this pin changes the switching frequency it also changes the on-time during PFM mode. At 1.4 MHz the on-time is twice the on-time as operating at 2.8 MHz. This pin has an active pulldown resistor of typically 400 k Ω . For applications where efficiency is of highest importance, a lower switching frequency should be selected. A higher switching frequency allows the use of smaller external components, faster load transient response and lower output voltage ripple when using same L-C values.

Undervoltage Lockout (UVLO)

To avoid mis-operation of the device at low input voltages, an undervoltage lockout is included. UVLO shuts down the device at input voltages lower than typically 2.2 V with a 200-mV hysteresis.

Thermal Shutdown

The device enters thermal shutdown once the junction temperature exceeds typically 150°C with a 20°C hysteresis.

APPLICATION INFORMATION

DESIGN PROCEDURE

The first step in the design procedure is the selection of the output filter components. To simplify this process, [Table 2](#) and [Table 3](#) outline possible inductor and capacitor value combinations.

Table 2. Output Filter Selection (2.8-MHz Operation, FREQ = GND)

INDUCTOR VALUE [μH] ⁽¹⁾	OUTPUT CAPACITOR VALUE [μF] ⁽²⁾				
	10	22	47	100	150
0.47		√ ⁽³⁾	√	√	√
1.0	√	√	√	√	√
2.2					
3.3					

- (1) Inductor tolerance and current de-rating is anticipated. The effective inductance varies by +20% and –30%.
- (2) Capacitance tolerance and bias voltage de-rating is anticipated. The effective capacitance varies by +20% and –50%.
- (3) Typical application configuration. Other check marks indicate alternative filter combinations.

Table 3. Output Filter Selection (1.4-MHz Operation, FREQ = V_{IN})

INDUCTOR VALUE [μH] ⁽¹⁾	OUTPUT CAPACITOR VALUE [μF] ⁽²⁾				
	10	22	47	100	150
0.47		√	√	√	√
1.0	√	√ ⁽³⁾	√	√	√
2.2	√	√	√	√	√
3.3					

- (1) Inductor tolerance and current de-rating is anticipated. The effective inductance varies by +20% and –30%.
- (2) Capacitance tolerance and bias voltage de-rating is anticipated. The effective capacitance varies by +20% and –50%.
- (3) Typical application configuration. Other check marks indicate alternative filter combinations.

Inductor Selection

The inductor selection is affected by several parameters such as inductor-ripple current, output-voltage ripple, transition point into Power Save Mode, and efficiency. See [Table 4](#) for typical inductors.

Table 4. Inductor Selection

INDUCTOR VALUE	COMPONENT SUPPLIER	SIZE (L × W × H mm)	I _{sat} / DCR
0.6 μH	Coilcraft XAL4012-601	4 × 4 × 2.1	7.1 A / 9.5 mΩ
1 μH	Coilcraft XAL4020-102	4 × 4 × 2.1	5.9 A / 13.2 mΩ
1 μH	Coilcraft XFL4020-102	4 × 4 × 2.1	5.1 A / 10.8 mΩ
0.47 μH	TOKO DFE252012 R47	2.5 × 2 × 1.2	3.7 A / 39 mΩ
1 μH	TOKO DFE252012 1R0	2.5 × 2 × 1.2	3.0 A / 59 mΩ
0.68 μH	TOKO DFE322512 R68	3.2 × 2.5 × 1.2	3.5 A / 37 mΩ
1 μH	TOKO DFE322512 1R0	3.2 × 2.5 × 1.2	3.1 A / 45 mΩ

In addition, the inductor must be rated for the appropriate saturation current and DC resistance (DCR). The inductor must be rated for a saturation current as high as the typical switch current limit, of 4.6 A or according to [Equation 7](#) and [Equation 8](#). [Equation 7](#) and [Equation 8](#) calculate the maximum inductor current under static load conditions. The formula takes the converter efficiency into account. The converter efficiency is taken from the [TYPICAL CHARACTERISTICS](#) graphs or 80% can be used as a conservative approach. The calculation must be done for the maximum input voltage where the peak switch current is highest.

$$I_L = I_{OUT} + \frac{\Delta I_L}{2} \quad (7)$$

$$I_L = I_{OUT} + \frac{V_{OUT}}{\eta} \times \left(1 - \frac{V_{OUT}}{V_{IN} \times \eta} \right)$$

where

- f = Converter switching frequency (typical 2.8 MHz or 1.4 MHz)
 - L = Selected inductor value
 - η = Estimated converter efficiency (use the number from the efficiency curves or 0.80 as a conservative assumption)
- (8)

NOTE

The calculation must be done for the maximum input voltage of the application

Calculating the maximum inductor current using the actual operating conditions gives the minimum saturation current. A margin of 20% must be added to cover for load transients during operation.

Input and Output Capacitor Selection

For best output and input voltage filtering, low ESR ceramic capacitors are recommended. The input capacitor minimizes input voltage ripple, suppresses input voltage spikes and provides a stable system rail for the device. A 22- μ F or larger input capacitor is recommended for 1.4-MHz operation frequency. For 2.8-MHz operation frequency a 10- μ F input capacitor or larger is recommended. The output capacitor value ranges from 10 μ F up to 150 μ F and beyond. The recommended typical output capacitor value is 22 μ F and varies over a wide range as outlined in the output filter selection table.

Table 5. Input Capacitor Selection

INPUT CAPACITOR	COMMENT
10 μ F	FREQ = low, $f = 2.8$ MHz
22 μ F	FREQ = high, $f = 1.4$ MHz

Setting the Output Voltage

The output voltage is set by an external resistor divider according to [Equation 9](#), [Equation 10](#), and [Equation 11](#).

$$V_{OUT} = V_{FB} \times \left(1 + \frac{R1}{R2} \right) = 0.8 \text{ V} \times \left(1 + \frac{R1}{R2} \right)$$
(9)

$$R2 = \frac{V_{FB}}{I_{FB}} = \frac{0.8 \text{ V}}{5 \mu\text{A}} \approx 160 \text{ k}\Omega$$
(10)

$$R1 = R2 \times \left(\frac{V_{OUT}}{V_{FB}} - 1 \right) = R2 \times \left(\frac{V_{OUT}}{0.8\text{V}} - 1 \right)$$
(11)

When sizing R2, use a minimum of 5 μ A for the feedback current, I_{FB} , in order to achieve low quiescent current and acceptable noise sensitivity. Larger currents through R2 improve noise sensitivity and output voltage accuracy. The lowest quiescent current and best output voltage accuracy are achieved with the fixed output-voltage versions. For the fixed output-voltage versions, leave the FB pin floating or connected to GND to improve the thermal package performance.

Layout Guideline

TI recommends placing all components as close as possible to the IC. The VOS connection is noise sensitive and must be routed as short and directly to the output terminal of the inductor. The exposed thermal pad of the package, analog ground (pin 6) and power ground (pin 14, 15) should have a single joint connection at the exposed thermal pad of the package, which minimizes switch node jitter. The charge-pump capacitor connected to CP and CN should be placed close to the IC to minimize coupling of switching waveforms into other traces and circuits. Refer to the evaluation module User Guide ([SLVU670](#)) for an example of component placement, routing and thermal design.

TYPICAL APPLICATIONS

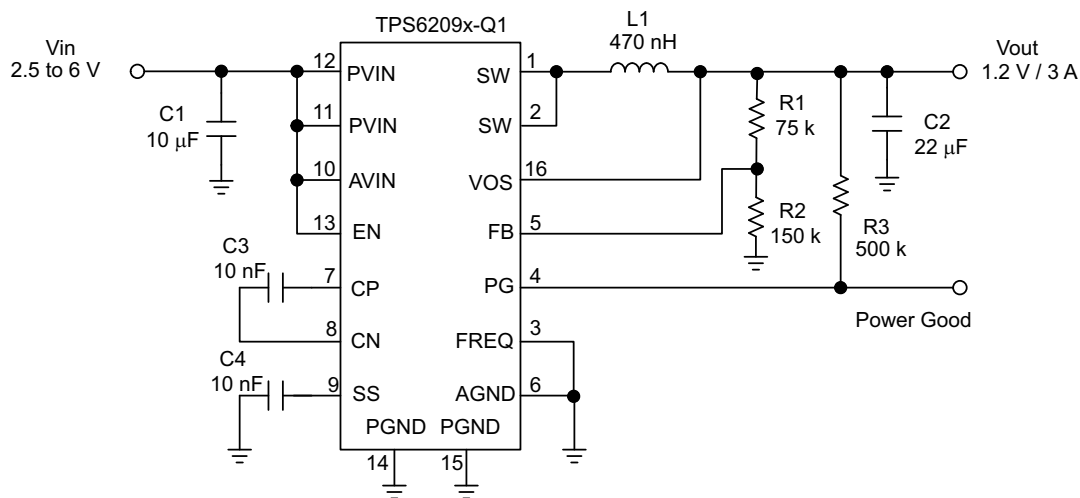

Figure 29. 1.2-V Adjustable Version Operating at 2.8 MHz

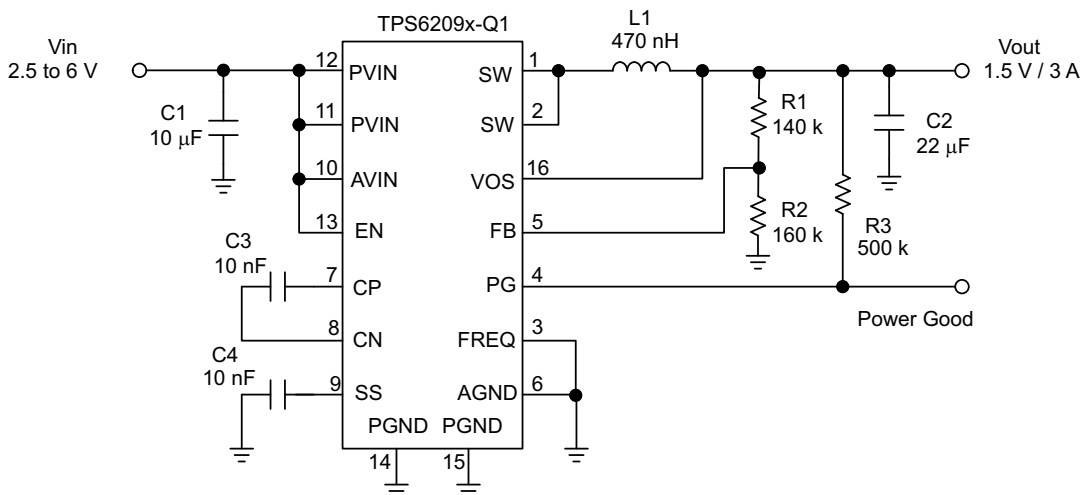

Figure 30. 1.5-V Adjustable Version Operating at 2.8 MHz

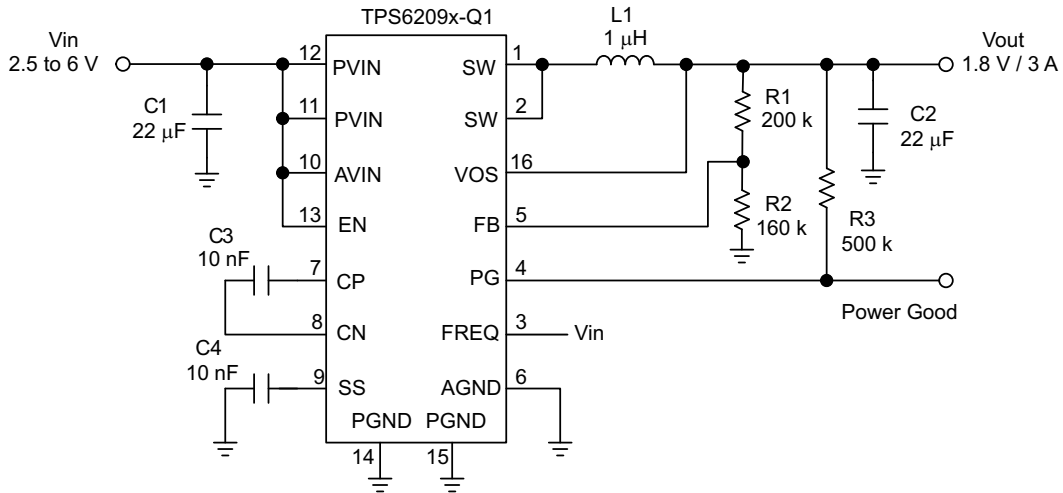

Figure 31. 1.8-V Adjustable Version Operating at 1.4 MHz

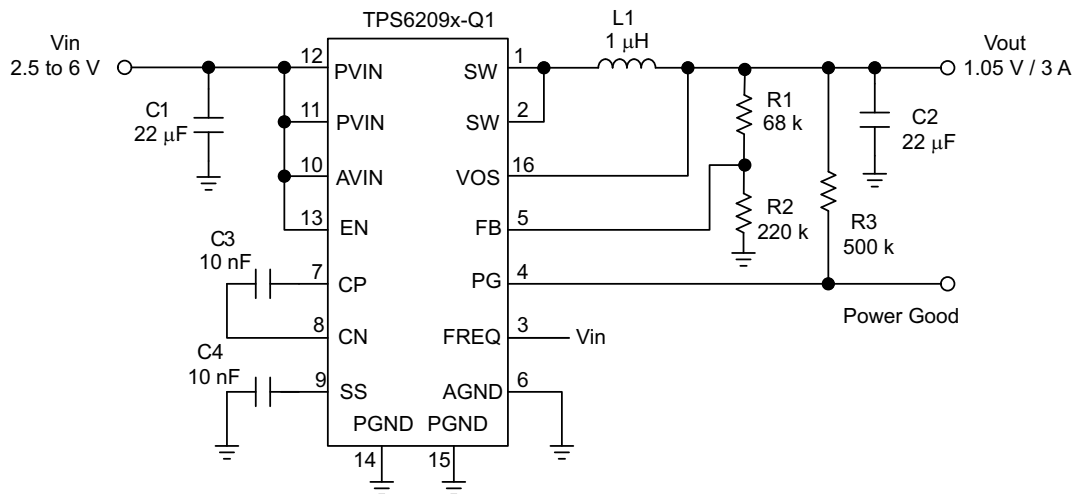

Figure 32. 1.05-V Adjustable Version Operating at 1.4 MHz

PACKAGING INFORMATION

Orderable Device	Status (1)	Package Type	Package Drawing	Pins	Package Qty	Eco Plan (2)	Lead/Ball Finish	MSL Peak Temp (3)	Op Temp (°C)	Device Marking (4/5)	Samples
TPS62090QRGTRQ1	ACTIVE	QFN	RGT	16	3000	Green (RoHS & no Sb/Br)	CU NIPDAU	Level-2-260C-1 YEAR	-40 to 125	SJG	Samples

(1) The marketing status values are defined as follows:

ACTIVE: Product device recommended for new designs.

LIFEBUY: TI has announced that the device will be discontinued, and a lifetime-buy period is in effect.

NRND: Not recommended for new designs. Device is in production to support existing customers, but TI does not recommend using this part in a new design.

PREVIEW: Device has been announced but is not in production. Samples may or may not be available.

OBSOLETE: TI has discontinued the production of the device.

(2) Eco Plan - The planned eco-friendly classification: Pb-Free (RoHS), Pb-Free (RoHS Exempt), or Green (RoHS & no Sb/Br) - please check <http://www.ti.com/productcontent> for the latest availability information and additional product content details.

TBD: The Pb-Free/Green conversion plan has not been defined.

Pb-Free (RoHS): TI's terms "Lead-Free" or "Pb-Free" mean semiconductor products that are compatible with the current RoHS requirements for all 6 substances, including the requirement that lead not exceed 0.1% by weight in homogeneous materials. Where designed to be soldered at high temperatures, TI Pb-Free products are suitable for use in specified lead-free processes.

Pb-Free (RoHS Exempt): This component has a RoHS exemption for either 1) lead-based flip-chip solder bumps used between the die and package, or 2) lead-based die adhesive used between the die and leadframe. The component is otherwise considered Pb-Free (RoHS compatible) as defined above.

Green (RoHS & no Sb/Br): TI defines "Green" to mean Pb-Free (RoHS compatible), and free of Bromine (Br) and Antimony (Sb) based flame retardants (Br or Sb do not exceed 0.1% by weight in homogeneous material)

(3) MSL, Peak Temp. -- The Moisture Sensitivity Level rating according to the JEDEC industry standard classifications, and peak solder temperature.

(4) There may be additional marking, which relates to the logo, the lot trace code information, or the environmental category on the device.

(5) Multiple Device Markings will be inside parentheses. Only one Device Marking contained in parentheses and separated by a "-" will appear on a device. If a line is indented then it is a continuation of the previous line and the two combined represent the entire Device Marking for that device.

Important Information and Disclaimer: The information provided on this page represents TI's knowledge and belief as of the date that it is provided. TI bases its knowledge and belief on information provided by third parties, and makes no representation or warranty as to the accuracy of such information. Efforts are underway to better integrate information from third parties. TI has taken and continues to take reasonable steps to provide representative and accurate information but may not have conducted destructive testing or chemical analysis on incoming materials and chemicals. TI and TI suppliers consider certain information to be proprietary, and thus CAS numbers and other limited information may not be available for release.

In no event shall TI's liability arising out of such information exceed the total purchase price of the TI part(s) at issue in this document sold by TI to Customer on an annual basis.

OTHER QUALIFIED VERSIONS OF TPS62090-Q1 :

- Catalog: [TPS62090](#)

NOTE: Qualified Version Definitions:

- Catalog - TI's standard catalog product

TAPE AND REEL INFORMATION



QUADRANT ASSIGNMENTS FOR PIN 1 ORIENTATION IN TAPE



*All dimensions are nominal

Device	Package Type	Package Drawing	Pins	SPQ	Reel Diameter (mm)	Reel Width W1 (mm)	A0 (mm)	B0 (mm)	K0 (mm)	P1 (mm)	W (mm)	Pin1 Quadrant
TPS62090QRGTRQ1	QFN	RGT	16	3000	330.0	12.4	3.3	3.3	1.1	8.0	12.0	Q2

TAPE AND REEL BOX DIMENSIONS



*All dimensions are nominal

Device	Package Type	Package Drawing	Pins	SPQ	Length (mm)	Width (mm)	Height (mm)
TPS62090QRGTRQ1	QFN	RGT	16	3000	367.0	367.0	35.0

RGT (S-PVQFN-N16)

PLASTIC QUAD FLATPACK NO-LEAD

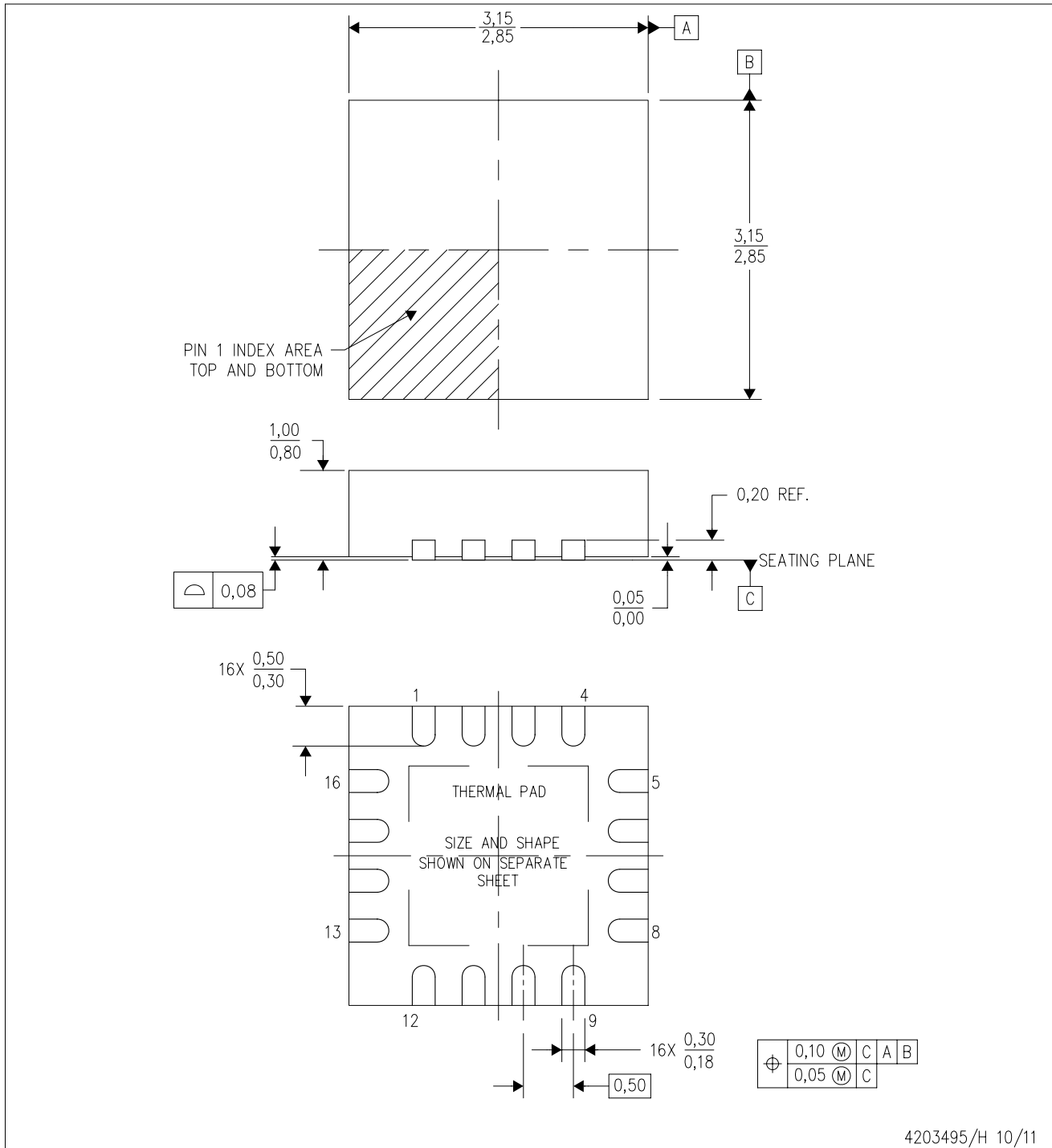

4203495/H 10/11

- NOTES:
- All linear dimensions are in millimeters. Dimensioning and tolerancing per ASME Y14.5M-1994.
 - This drawing is subject to change without notice.
 - Quad Flatpack, No-leads (QFN) package configuration.
 - The package thermal pad must be soldered to the board for thermal and mechanical performance.
 - See the additional figure in the Product Data Sheet for details regarding the exposed thermal pad features and dimensions.
 - Falls within JEDEC MO-220.

THERMAL PAD MECHANICAL DATA

RGT (S-PVQFN-N16)

PLASTIC QUAD FLATPACK NO-LEAD

THERMAL INFORMATION

This package incorporates an exposed thermal pad that is designed to be attached directly to an external heatsink. The thermal pad must be soldered directly to the printed circuit board (PCB). After soldering, the PCB can be used as a heatsink. In addition, through the use of thermal vias, the thermal pad can be attached directly to the appropriate copper plane shown in the electrical schematic for the device, or alternatively, can be attached to a special heatsink structure designed into the PCB. This design optimizes the heat transfer from the integrated circuit (IC).

For information on the Quad Flatpack No-Lead (QFN) package and its advantages, refer to Application Report, QFN/SON PCB Attachment, Texas Instruments Literature No. SLUA271. This document is available at www.ti.com.

The exposed thermal pad dimensions for this package are shown in the following illustration.

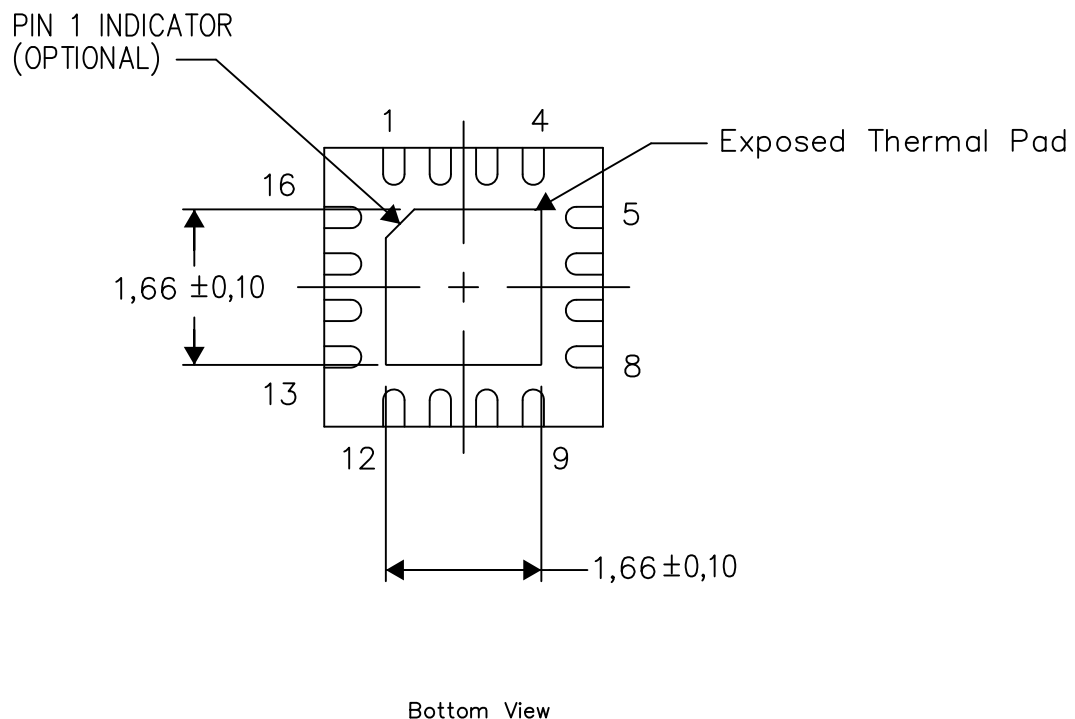

Exposed Thermal Pad Dimensions

4206349-10/Z 08/15

NOTE: All linear dimensions are in millimeters

RGT (S-PVQFN-N16)

PLASTIC QUAD FLATPACK NO-LEAD

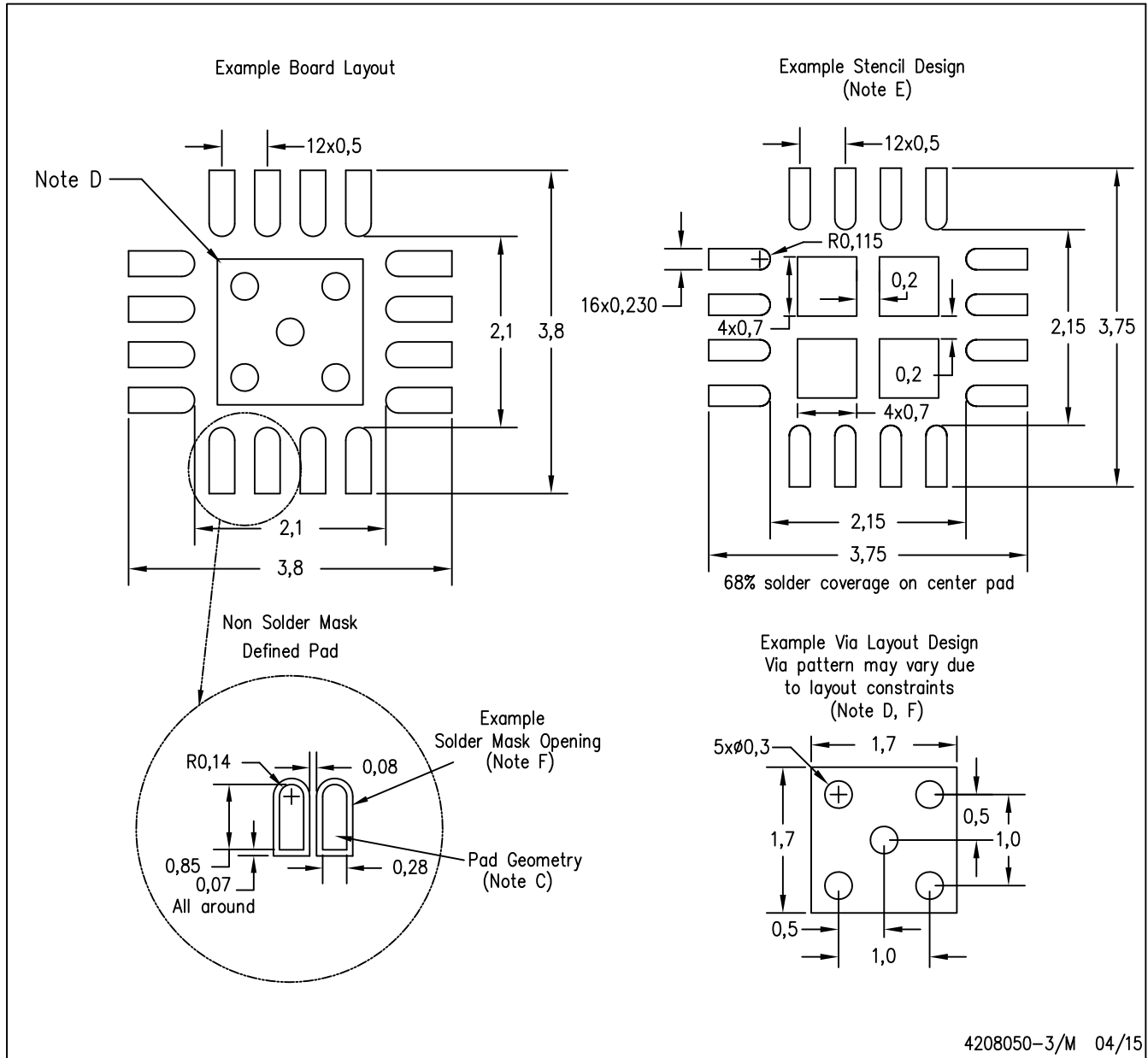

4208050-3/M 04/15

- NOTES:
- A. All linear dimensions are in millimeters.
 - B. This drawing is subject to change without notice.
 - C. Publication IPC-7351 is recommended for alternate designs.
 - D. This package is designed to be soldered to a thermal pad on the board. Refer to Application Note, QFN/SON PCB Attachment, Texas Instruments Literature No. SLUA271, and also the Product Data Sheets for specific thermal information, via requirements, and recommended board layout. These documents are available at www.ti.com <<http://www.ti.com>>.
 - E. Laser cutting apertures with trapezoidal walls and also rounding corners will offer better paste release. Customers should contact their board assembly site for stencil design recommendations. Refer to IPC 7525 for stencil design considerations.
 - F. Customers should contact their board fabrication site for minimum solder mask web tolerances between signal pads.

IMPORTANT NOTICE

Texas Instruments Incorporated and its subsidiaries (TI) reserve the right to make corrections, enhancements, improvements and other changes to its semiconductor products and services per JESD46, latest issue, and to discontinue any product or service per JESD48, latest issue. Buyers should obtain the latest relevant information before placing orders and should verify that such information is current and complete. All semiconductor products (also referred to herein as "components") are sold subject to TI's terms and conditions of sale supplied at the time of order acknowledgment.

TI warrants performance of its components to the specifications applicable at the time of sale, in accordance with the warranty in TI's terms and conditions of sale of semiconductor products. Testing and other quality control techniques are used to the extent TI deems necessary to support this warranty. Except where mandated by applicable law, testing of all parameters of each component is not necessarily performed.

TI assumes no liability for applications assistance or the design of Buyers' products. Buyers are responsible for their products and applications using TI components. To minimize the risks associated with Buyers' products and applications, Buyers should provide adequate design and operating safeguards.

TI does not warrant or represent that any license, either express or implied, is granted under any patent right, copyright, mask work right, or other intellectual property right relating to any combination, machine, or process in which TI components or services are used. Information published by TI regarding third-party products or services does not constitute a license to use such products or services or a warranty or endorsement thereof. Use of such information may require a license from a third party under the patents or other intellectual property of the third party, or a license from TI under the patents or other intellectual property of TI.

Reproduction of significant portions of TI information in TI data books or data sheets is permissible only if reproduction is without alteration and is accompanied by all associated warranties, conditions, limitations, and notices. TI is not responsible or liable for such altered documentation. Information of third parties may be subject to additional restrictions.

Resale of TI components or services with statements different from or beyond the parameters stated by TI for that component or service voids all express and any implied warranties for the associated TI component or service and is an unfair and deceptive business practice. TI is not responsible or liable for any such statements.

Buyer acknowledges and agrees that it is solely responsible for compliance with all legal, regulatory and safety-related requirements concerning its products, and any use of TI components in its applications, notwithstanding any applications-related information or support that may be provided by TI. Buyer represents and agrees that it has all the necessary expertise to create and implement safeguards which anticipate dangerous consequences of failures, monitor failures and their consequences, lessen the likelihood of failures that might cause harm and take appropriate remedial actions. Buyer will fully indemnify TI and its representatives against any damages arising out of the use of any TI components in safety-critical applications.

In some cases, TI components may be promoted specifically to facilitate safety-related applications. With such components, TI's goal is to help enable customers to design and create their own end-product solutions that meet applicable functional safety standards and requirements. Nonetheless, such components are subject to these terms.

No TI components are authorized for use in FDA Class III (or similar life-critical medical equipment) unless authorized officers of the parties have executed a special agreement specifically governing such use.

Only those TI components which TI has specifically designated as military grade or "enhanced plastic" are designed and intended for use in military/aerospace applications or environments. Buyer acknowledges and agrees that any military or aerospace use of TI components which have **not** been so designated is solely at the Buyer's risk, and that Buyer is solely responsible for compliance with all legal and regulatory requirements in connection with such use.

TI has specifically designated certain components as meeting ISO/TS16949 requirements, mainly for automotive use. In any case of use of non-designated products, TI will not be responsible for any failure to meet ISO/TS16949.

Products

Audio	www.ti.com/audio
Amplifiers	amplifier.ti.com
Data Converters	dataconverter.ti.com
DLP® Products	www.dlp.com
DSP	dsp.ti.com
Clocks and Timers	www.ti.com/clocks
Interface	interface.ti.com
Logic	logic.ti.com
Power Mgmt	power.ti.com
Microcontrollers	microcontroller.ti.com
RFID	www.ti-rfid.com
OMAP Applications Processors	www.ti.com/omap
Wireless Connectivity	www.ti.com/wirelessconnectivity

Applications

Automotive and Transportation	www.ti.com/automotive
Communications and Telecom	www.ti.com/communications
Computers and Peripherals	www.ti.com/computers
Consumer Electronics	www.ti.com/consumer-apps
Energy and Lighting	www.ti.com/energy
Industrial	www.ti.com/industrial
Medical	www.ti.com/medical
Security	www.ti.com/security
Space, Avionics and Defense	www.ti.com/space-avionics-defense
Video and Imaging	www.ti.com/video

TI E2E Community

e2e.ti.com