

TPS6209x 3A High Efficient Synchronous Step Down Converter with DCS™ Control

1 Features

- 2.5 V to 6 V Input Voltage Range
- DCS™ Control
- 95% Converter Efficiency
- Power Save Mode
- 20 μ A Operating Quiescent Current
- 100% Duty Cycle for Lowest Dropout
- 2.8 MHz/1.4 MHz Typical Switching Frequency
- 0.8 V to V_{IN} Adjustable Output Voltage
- Fixed Output Voltage Versions
- Output Discharge Function
- Adjustable Softstart
- Two Level Short Circuit Protection
- Output Voltage Tracking
- Wide Output Capacitance Selection

2 Applications

- Distributed Power Supplies
- Notebook, Netbook Computers
- Hard Disk Drivers (HDD)
- Solid State Drives (SSD)
- Processor Supply
- Battery Powered Applications

3 Description

The TPS6209x device family is a high frequency synchronous step down converter optimized for small solution size, high efficiency and suitable for battery powered applications. To maximize efficiency, the converter operates in PWM mode with a nominal switching frequency of 2.8 MHz/1.4 MHz and automatically enters Power Save Mode operation at light load currents. When used in distributed power supplies and point of load regulation, the device allows voltage tracking to other voltage rails and tolerates output capacitors ranging from 10 μ F up to 150 μ F and beyond. Using the DCS™ Control topology the device achieves excellent load transient performance and accurate output voltage regulation.

The output voltage start-up ramp is controlled by the softstart pin, which allows operation as either a standalone power supply or in tracking configurations. Power sequencing is also possible by configuring the Enable and Power Good pins. In Power Save Mode, the device operates at typically 20 μ A quiescent current. Power Save Mode is entered automatically and seamlessly maintaining high efficiency over the entire load current range.

Device Information⁽¹⁾

DEVICE NAME	PACKAGE	BODY SIZE
TPS62090	QFN (16)	3mm x 3mm
TPS62091		
TPS62092		
TPS62093		

(1) For all available packages, see the orderable addendum at the end of the data sheet.

4 Simplified Schematic

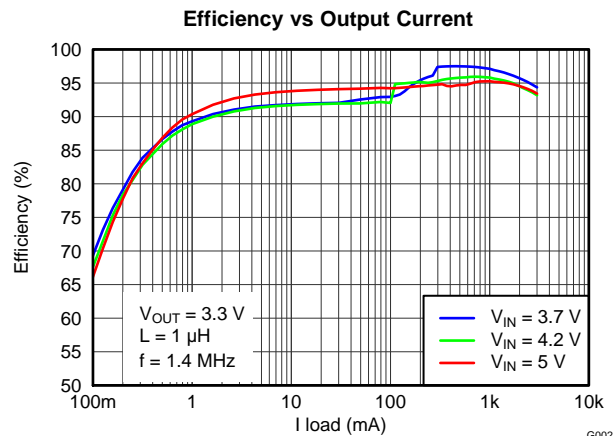
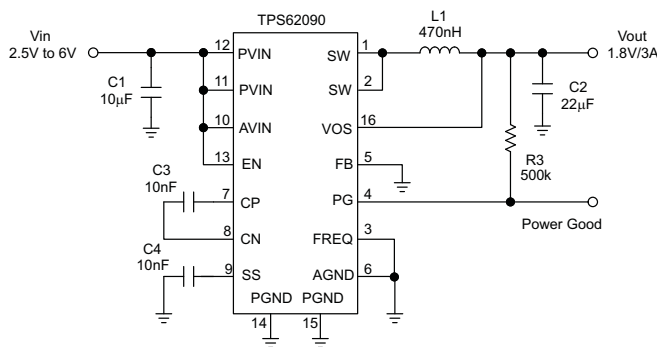

G002



Table of Contents

1 Features	1	9.3 Feature Description	9
2 Applications	1	9.4 Device Functional Modes	9
3 Description	1	10 Application and Implementation	12
4 Simplified Schematic	1	10.1 Application Information	12
5 Revision History	2	10.2 Typical Applications	12
6 Pin Configuration and Functions	3	11 Power Supply Recommendations	18
7 Specifications	4	12 Layout	19
7.1 Absolute Maximum Ratings	4	12.1 Layout Guideline	19
7.2 Handling Ratings	4	12.2 Layout Example	19
7.3 Recommended Operating Conditions	4	13 Device and Documentation Support	20
7.4 Thermal Information	4	13.1 Device Support	20
7.5 Electrical Characteristics	5	13.2 Related Links	20
7.6 Typical Characteristics	6	13.3 Trademarks	20
8 Parametric Measurement Information	7	13.4 Electrostatic Discharge Caution	20
9 Detailed Description	8	13.5 Glossary	20
9.1 Overview	8	14 Mechanical, Packaging, and Orderable Information	20
9.2 Functional Block Diagram	8		

5 Revision History

NOTE: Page numbers for previous revisions may differ from page numbers in the current version.

Changes from Revision A (March 2012) to Revision B	Page
• Changed the data sheet to meet the new TI standard Format	1
• Changed the Typical Characteristics. Moved graphs to the Application and Implementation section	6
• Changed R3 and R4 values in Figure 8	11
• Changed Equation 5	11
• Added Equation 7	11
• Added the Layout section	19

Changes from Original (March 2012) to Revision A	Page
• Changed the FUNCTIONAL BLOCK DIAGRAM	8
• Changed R1, R2 and R4 values in Figure 8	11
• Changed R1 and R2 values in Figure 9	12

Device Comparison Table

DEVICE NUMBER	OUTPUT VOLTAGE
TPS62090	Adjustable
TPS62091	3.3 V
TPS62092	2.5 V
TPS62093	1.8 V

6 Pin Configuration and Functions

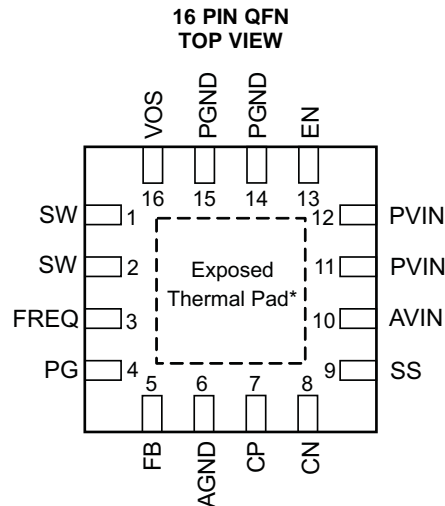

NOTE: *The exposed Thermal Pad is connected to AGND.

Pin Functions

PIN		I/O	DESCRIPTION
NAME	NO.		
SW	1, 2	I	Switch pin of the power stage.
FREQ	3	I	This pin selects the switching frequency of the device. FREQ=low sets the typical switching frequency to 2.8 MHz. FREQ=high sets the typical switching frequency to 1.4 MHz. This pin has an active pull down resistor of typically 400 kΩ and can be left floating for 2.8 MHz operation.
PG	4	O	Power good open drain output. This pin is high impedance if the output voltage is within regulation. This pin is pulled low if the output is below its nominal value. The pull up resistor can not be connected to any voltage higher than the input voltage of the device.
FB	5		Feedback pin of the device. For the fixed output voltage versions this pin needs to be connected to GND for improved thermal performance. If, desired then this pin can also be left floating since it is internally connected with 400 kΩ to GND for fixed output voltage versions.
AGND	6		Analog ground.
CP	7		Internal charge pump flying capacitor. Connect a 10 nF capacitor between CP and CN.
CN	8		Internal charge pump flying capacitor. Connect a 10 nF capacitor between CP and CN.
SS	9	I	Soft-start control pin. A capacitor is connected to this pin and sets the softstart time. Leaving this pin floating sets the minimum start-up time.
AVIN	10		Bias supply input voltage pin.
PVIN	11,12		Power supply input voltage pin.
EN	13		Device enable. To enable the device this pin needs to be pulled high. Pulling this pin low disables the device. This pin has an active pull down resistor of typically 400 kΩ.
PGND	14,15		Power ground connection.
VOS	16		Output voltage sense pin. This pin needs to be connected to the output voltage.
Thermal Pad			The exposed thermal pad is connected to AGND.

7 Specifications

7.1 Absolute Maximum Ratings⁽¹⁾

over operating free-air temperature range (unless otherwise noted)

		VALUE		UNIT
		MIN	MAX	
Voltage range	PVIN, AVIN, FB, SS, EN, FREQ, VOS ⁽²⁾	-0.3	7	V
	SW, PG	-0.3	V _{IN} +0.3	V
Power Good sink current	PG		1	mA
Continuous total power dissipation		See the Thermal Table		
Operating junction temperature range, T _J		-40	150	°C

- (1) Stresses beyond those listed under “absolute maximum ratings” may cause permanent damage to the device. These are stress ratings only and functional operation of the device at these or any other conditions beyond those indicated under “recommended operating conditions” is not implied. Exposure to absolute–maximum–rated conditions for extended periods may affect device reliability.
- (2) All voltage values are with respect to network ground pin.

7.2 Handling Ratings

			MIN	MAX	UNIT
T _{stg}	Storage temperature range		-65	150	°C
V _(ESD)	Electrostatic discharge	Human body model (HBM) per ANSI/ESDA/JEDEC JS-001, all pins ⁽¹⁾	-2	2	kV
		Charged device model (CDM), per JEDEC specification JESD22-C101, all pins ⁽²⁾	-500	500	V

- (1) JEDEC document JEP155 states that 500-V HBM allows safe manufacturing with a standard ESD control process.
- (2) JEDEC document JEP157 states that 250-V CDM allows safe manufacturing with a standard ESD control process.

7.3 Recommended Operating Conditions⁽¹⁾

		MIN	TYP	MAX	UNIT
V _{IN}	Input voltage range V _{IN}	2.5		6	V
T _A	Operating ambient temperature	-40		85	°C
T _J	Operating junction temperature	-40		125	°C

- (1) See the application section for further information

7.4 Thermal Information

THERMAL METRIC ⁽¹⁾		TPS6209x	UNIT
		QFN (16 PINS)	
R _{θJA}	Junction-to-ambient thermal resistance	47	°C/W
R _{θJctop}	Junction-to-case (top) thermal resistance	60	
R _{θJB}	Junction-to-board thermal resistance	20	
ψ _{JT}	Junction-to-top characterization parameter	1.5	
ψ _{JB}	Junction-to-board characterization parameter	20	
R _{θJcbot}	Junction-to-case (bottom) thermal resistance	5.3	

- (1) For more information about traditional and new thermal metrics, see the *IC Package Thermal Metrics* application report, [SPRA953](#).

7.5 Electrical Characteristics

 $V_{IN} = 3.6V$, $T_A = -40^{\circ}C$ to $85^{\circ}C$, typical values are at $T_A = 25^{\circ}C$ (unless otherwise noted)

PARAMETER		TEST CONDITIONS	MIN	TYP	MAX	UNIT
SUPPLY						
V_{IN}	Input voltage range		2.5		6	V
I_{QIN}	Quiescent current	Not switching, FB = FB +5 %, Into PVIN and AVIN		20		μA
I_{sd}	Shutdown current	Into PVIN and AVIN		0.6	5	μA
UVLO	Undervoltage lockout threshold	V_{IN} falling	2.1	2.2	2.3	V
	Undervoltage lockout hysteresis			200		mV
	Thermal shutdown	Temperature rising		150		$^{\circ}C$
	Thermal shutdown hysteresis			20		$^{\circ}C$
Control SIGNALS EN, FREQ						
V_H	High level input voltage	$V_{IN} = 2.5 V$ to $6 V$	1			V
V_L	Low level input voltage	$V_{IN} = 2.5 V$ to $6 V$			0.4	V
I_{lkg}	Input leakage current	EN, FREQ = GND or V_{IN}		10	100	nA
R_{PD}	Pull down resistance			400		k Ω
Softstart						
I_{SS}	Softstart current		6.3	7.5	8.7	μA
POWER GOOD						
V_{th}	Power good threshold	Output voltage rising		95%		
		Output voltage falling		90%		
V_L	Low level voltage	$I_{(sink)} = 1mA$			0.4	V
I_{PG}	PG sinking current				1	mA
I_{lkg}	Leakage current	$V_{PG} = 3.6V$		10	100	nA
POWER SWITCH						
$R_{DS(on)}$	High side FET on-resistance	$I_{SW} = 500 mA$		50		m Ω
	Low side FET on-resistance	$I_{SW} = 500 mA$		40		m Ω
I_{LIM}	High side FET switch current limit		3.7	4.6	5.5	A
f_s	Switching frequency	FREQ = GND, $I_{OUT} = 3 A$		2.8		MHz
		FREQ = VIN, $I_{OUT} = 3 A$		1.4		MHz
OUTPUT						
V_s	Output voltage range		0.8		V_{IN}	V
R_{od}	Output discharge resistor	EN = GND, $V_{OUT} = 1.8 V$		200		Ω
V_{FB}	Feedback regulation voltage			0.8		V
V_{FB}	Feedback voltage accuracy ^{(1) (2)(3)}	$V_{IN} \geq V_{OUT} + 1 V$, TPS62090 adjustable output version $I_{OUT} = 1 A$, PWM mode	-1.4%		+1.4%	
		$I_{OUT} = 0 mA$, FREQ = 2.8 MHz, $V_{OUT} \geq 0.8 V$, PFM mode	-1.4%		+3%	
		$I_{OUT} = 0 mA$, FREQ = 1.4 MHz, $V_{OUT} \geq 1.2 V$, PFM mode	-1.4%		+3%	
		$I_{OUT} = 0 mA$, FREQ = 1.4 MHz, $V_{OUT} < 1.2V$, PFM mode	-1.4%		+3.7%	
I_{FB}	Feedback input bias current	$V_{FB} = 0.8V$, TPS62090 adjustable output version		10	100	nA
V_{OUT}	Output voltage accuracy ⁽²⁾⁽³⁾	$V_{IN} \geq V_{OUT} + 1 V$, Fixed output voltage $I_{OUT} = 1 A$, PWM mode	-1.4%		+1.4%	
		$I_{OUT} = 0 mA$, FREQ = High and Low, PFM mode	-1.4%		+2.5%	
		Line regulation	$V_{OUT} = 1.8 V$, PWM operation		0.016	
	Load regulation	$V_{OUT} = 1.8 V$, PWM operation		0.04		%/A

(1) For output voltages < 1.2 V, use a 2 x 22 μF output capacitance to achieve +3% output voltage accuracy.

(2) Conditions: $f = 2.8 MHz$, $L = 0.47 \mu H$, $C_{OUT} = 22 \mu F$ or $f = 1.4 MHz$, $L = 1 \mu H$, $C_{OUT} = 22 \mu F$.

(3) For more information, see the [Power Save Mode Operation](#) section of this data sheet.

7.6 Typical Characteristics

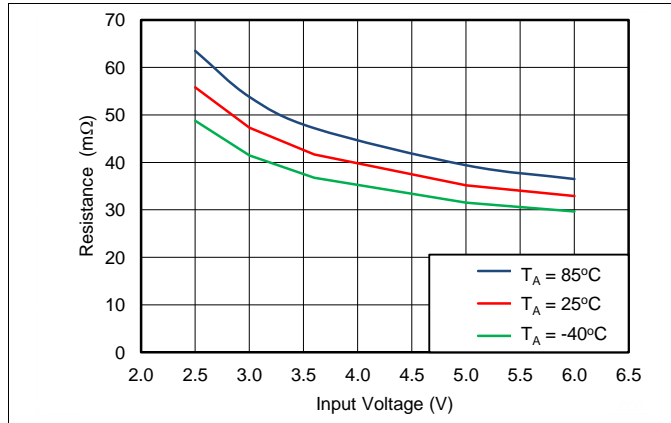

Figure 1. High Side FET On-Resistance vs Input Voltage

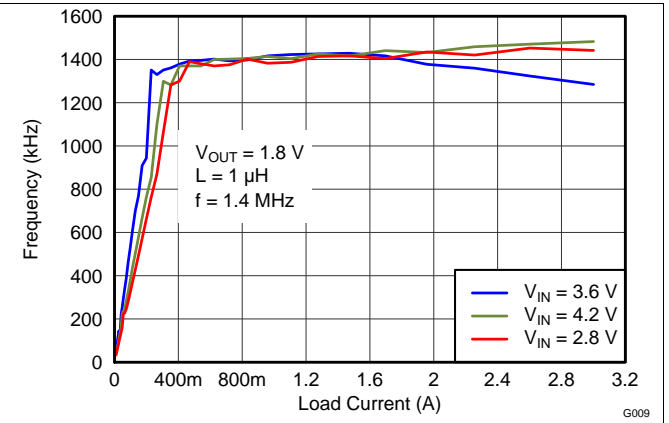

Figure 2. Switching Frequency vs Load Current

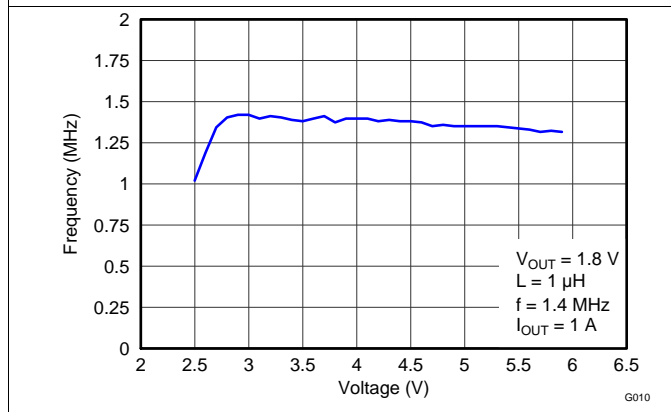

Figure 3. Switching Frequency vs Input Voltage

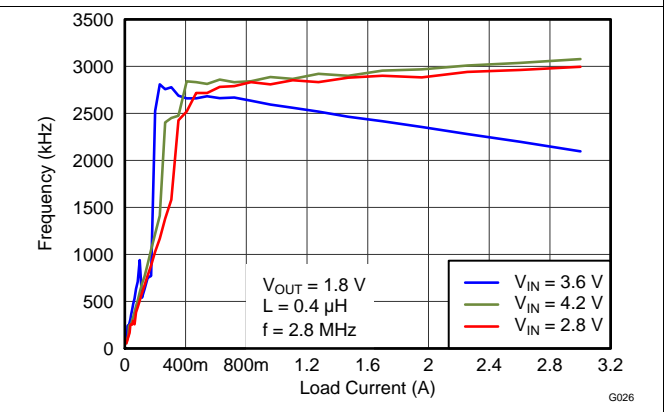

Figure 4. Frequency vs Load Current

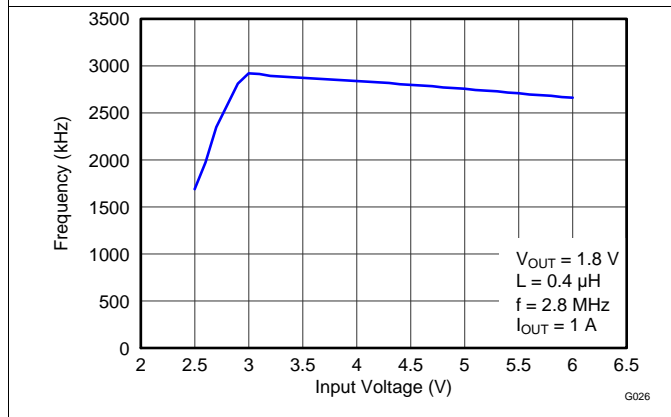

Figure 5. Frequency vs Input Voltage

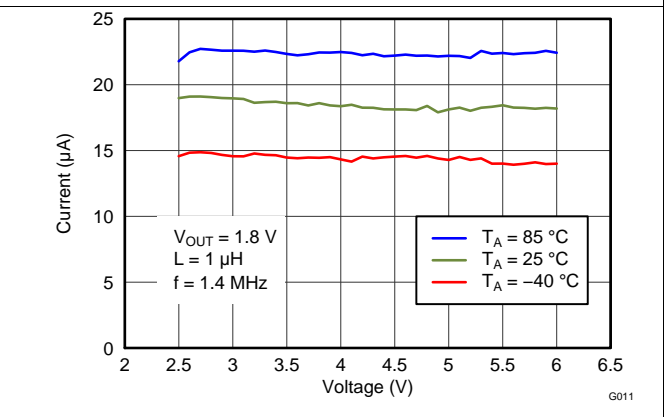

Figure 6. Quiescent Current vs Input Voltage

8 Parametric Measurement Information

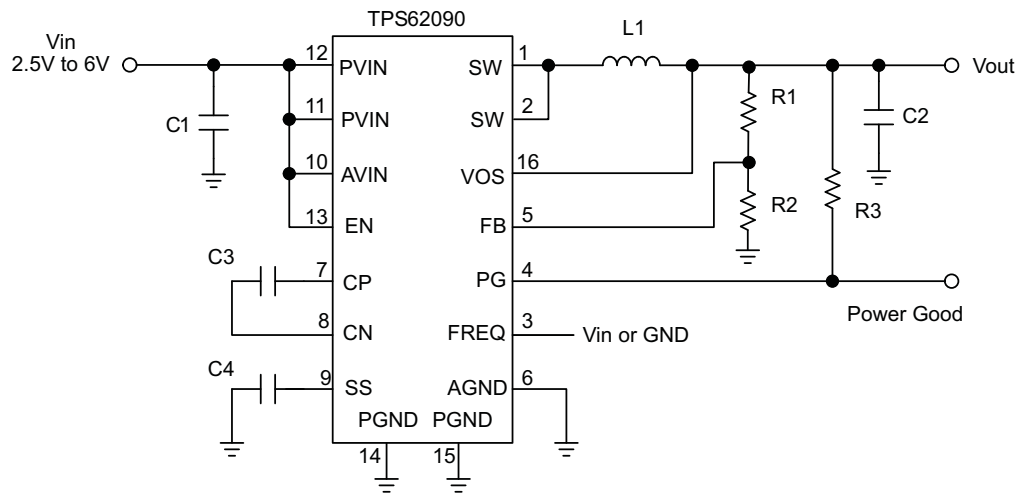

Figure 7. Parametric Measurement Circuit

List of Components

REFERENCE	DESCRIPTION	MANUFACTURER
TPS62090	High efficient step down converter	Texas Instruments
L1	Inductor: 1uH, 0.47uH, 0.4uH	Coilcraft XFL4020-102, XAL4020-401, TOKO DEF252012-R47
C1	Ceramic capacitor: 10uF, 22uF	(6.3V, X5R, 0603), (6.3V, X5R, 0805)
C2	Ceramic capacitor: 22uF	(6.3V, X5R, 0805)
C3, C4	Ceramic capacitor	Standard
R1, R2, R3	Resistor	Standard

9 Detailed Description

9.1 Overview

The TPS6209x synchronous switched mode converters are based on DCS™ Control (Direct Control with Seamless transition into Power Save Mode). This is an advanced regulation topology that combines the advantages of hysteretic and voltage mode control.

The DCS™ Control topology operates in PWM (Pulse Width Modulation) mode for medium to heavy load conditions and in Power Save Mode at light load currents. In PWM, the converter operates with its nominal switching frequency of 2.8 MHz/1.4 MHz having a controlled frequency variation over the input voltage range. As the load current decreases, the converter enters Power Save Mode, reducing the switching frequency and minimizing the IC quiescent current to achieve high efficiency over the entire load current range. DCS™ Control supports both operation modes (PWM and PFM) using a single building block having a seamless transition from PWM to Power Save Mode without effects on the output voltage. Fixed output voltage versions provide smallest solution size combined with lowest quiescent current. The TPS6209x family offers excellent DC voltage regulation and load transient regulation, combined with low output voltage ripple, minimizing interference with RF circuits.

9.2 Functional Block Diagram

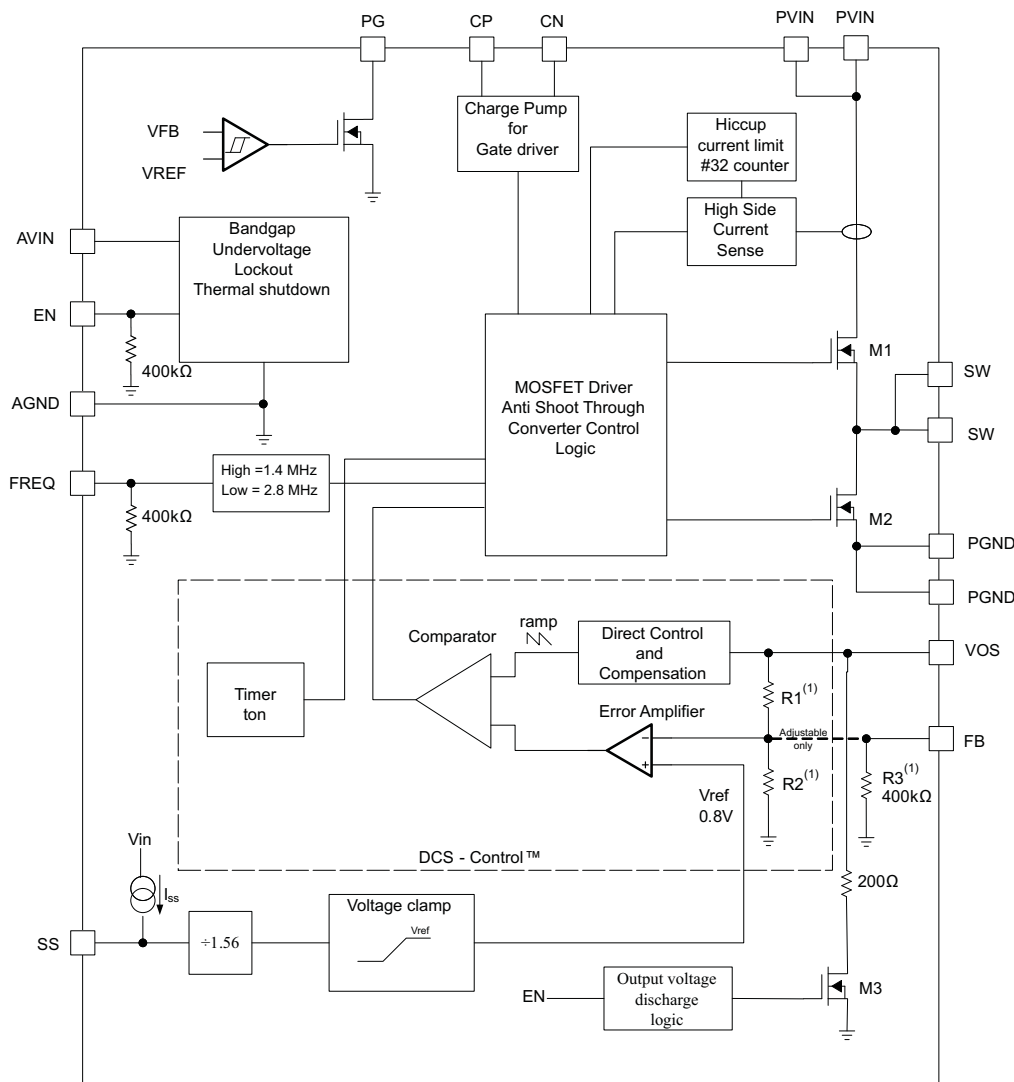

(1) R1, R2, R3 are implemented in the fixed output voltage version only.

9.3 Feature Description

9.3.1 Power Good Output (PG)

The power good output is low when the output voltage is below its nominal value. The power good will become high impedance once the output is within 5% of regulation. The PG pin is an open drain output and is specified to typically sink up to 1 mA. This output requires a pull-up resistor to be monitored properly. The pull-up resistor cannot be connected to any voltage higher than the input voltage of the device.

9.3.2 Frequency Set Pin (FREQ)

The FREQ pin is a digital logic input which sets the nominal switching frequency. Pulling this pin to GND sets the nominal switching frequency to 2.8 MHz and pulling this pin high sets the nominal switching frequency to 1.4 MHz. Since this pin changes the switching frequency it also changes the on-time during PFM mode. At 1.4 MHz the on-time is twice the on-time as operating at 2.8 MHz. This pin has an active pull-down resistor of typically 400 kΩ. For applications where efficiency is of highest importance, a lower switching frequency should be selected. A higher switching frequency allows the use of smaller external components, faster load transient response and lower output voltage ripple when using same L-C values.

9.3.3 Undervoltage Lockout (UVLO)

To avoid mis-operation of the device at low input voltages, an undervoltage lockout is included. UVLO shuts down the device at input voltages lower than typically 2.2 V with a 200 mV hysteresis.

9.3.4 Thermal Shutdown

The device goes into thermal shutdown once the junction temperature exceeds typically 150°C with a 20°C hysteresis.

9.4 Device Functional Modes

9.4.1 PWM Operation

At medium to heavy load currents, the device operates with pulse width modulation (PWM) at a nominal switching frequency of 2.8 MHz or 1.4 MHz depending on the setting of the FREQ pin. As the load current decreases, the converter enters the Power Save Mode operation reducing its switching frequency. The device enters Power Save Mode at the boundary to discontinuous conduction mode (DCM).

9.4.2 Power Save Mode Operation

As the load current decreases, the converter enters Power Save Mode operation. During Power Save Mode the converter operates with reduced switching frequency in PFM mode and with a minimum quiescent current while maintaining high efficiency. The Power Save Mode is based on a fixed on-time architecture following [Equation 1](#). When operating at 1.4 MHz the on-time is twice as long as the on-time for 2.8 MHz operation. This results in larger output voltage ripple, as shown in [Figure 19](#) and [Figure 20](#), and slightly higher output voltage at no load, as shown in [Figure 16](#) and [Figure 17](#). To have the same output voltage ripple at 1.4 MHz during PFM mode, either the output capacitor or the inductor value needs to be increased. As an example, operating at 2.8 MHz using 0.47 μH inductor gives the same output voltage ripple as operating with 1.4 MHz using 1 μH inductor.

$$\begin{aligned}
 t_{on_{2.8\text{MHz}}} &= \frac{V_{OUT}}{V_{IN}} \times 360\text{ns} \\
 t_{on_{1.4\text{MHz}}} &= \frac{V_{OUT}}{V_{IN}} \times 360\text{ns} \times 2 \\
 f &= \frac{2 \times I_{OUT}}{t_{on}^2 \left(1 + \frac{V_{IN} - V_{OUT}}{V_{OUT}} \right) \times \frac{V_{IN} - V_{OUT}}{L}}
 \end{aligned}
 \tag{1}$$

Device Functional Modes (continued)

In Power Save Mode the output voltage rises slightly above the nominal output voltage in PWM mode, as shown in [Figure 16](#) and [Figure 17](#). This effect can be reduced by increasing the output capacitance or the inductor value. This effect can also be reduced by programming the output voltage of the TPS62090 lower than the target value. As an example, if the target output voltage is 3.3 V, then the TPS62090 can be programmed to 3.3V - 0.8%. As a result the output voltage accuracy is now -2.2% to +2.2% instead of -1.4% to 3%. The output voltage accuracy in PFM operation is reflected in the electrical specification table and given for a 22 µF output capacitance.

9.4.3 Low Dropout Operation (100% Duty Cycle)

The device offers low input to output voltage difference by entering 100% duty cycle mode. In this mode the high side MOSFET switch is constantly turned on. This is particularly useful in battery powered applications to achieve longest operation time by taking full advantage of the whole battery voltage range. The minimum input voltage where the output voltage falls below its nominal regulation value is given by:

$$V_{IN(min)} = V_{OUT(max)} + I_{OUT} \times (R_{DS(on)} + R_L) \quad (2)$$

Where

$R_{DS(on)}$ = High side FET on-resistance

R_L = DC resistance of the inductor

$V_{OUT(max)}$ = nominal output voltage plus maximum output voltage tolerance

9.4.4 Softstart (SS)

To minimize inrush current during start up, the device has an adjustable softstart depending on the capacitor value connected to the SS pin. The device charges the softstart capacitor with a constant current of typically 7.5 µA. The feedback voltage follows this voltage with a fraction of 1.56 until the internal reference voltage of 0.8 V is reached. The softstart operation is completed once the voltage at the softstart capacitor has reached typically 1.25 V. The soft-start time can be calculated using [Equation 3](#). The larger the softstart capacitor the longer the softstart time. The relation between softstart voltage and feedback voltage can be estimated using [Equation 4](#).

$$t_{SS} = C_{SS} \times \frac{1.25V}{7.5\mu A} \quad (3)$$

$$V_{FB} = \frac{V_{SS}}{1.56} \quad (4)$$

This is also the case for the fixed output voltage option having the internal regulation voltage. During start-up the switch current limit is reduced to 1/3 (~1.5 A) of its typical current limit of 4.6 A. Once the output voltage exceeds typically 0.6 V the current limit is released to its nominal value. The device provides a reduced load current of ~1.5A when the output voltage is below typ 0.6V. Due to this, a small or no softstart time may trigger the short circuit protection during start-up especially for larger output capacitors >22µF. This can be avoided by using larger softstart capacitance extending the softstart time. See Short Circuit Protection (Hiccup-Mode) for details of the reduced current limit during startup. Leaving the softstart pin floating sets the minimum start-up time.

Device Functional Modes (continued)

9.4.5 Start-up Tracking (SS)

The softstart pin can also be be used to implement output voltage tracking with other supply rails. The internal reference voltage follows the voltage at the softstart pin with a fraction of 1.56 until the internal reference voltage of 0.8 V is reached. The softstart pin can be used to implement output voltage tracking as shown in [Figure 8](#).

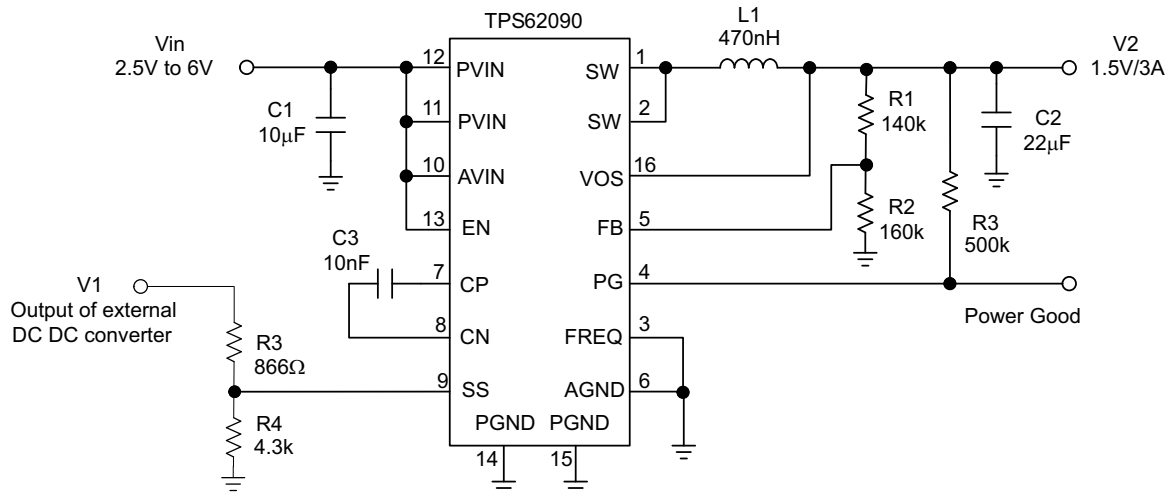

Figure 8. Output Voltage Tracking

In [Figure 8](#), the output V2 will track the voltage applied to V1. Simultaneous voltage tracking is possible for output voltages of $V2 \geq 1.25$ V. The voltage will track simultaneously when following conditions are met:

$$1 + \frac{R3}{R4} = \left(1 + \frac{R1}{R2}\right) \times \frac{1}{1.56} \quad (5)$$

As the fraction of $R3/R4$ becomes larger the voltage V1 will ramp up faster than V2. If it gets smaller, then the ramp will be slower than V2. R4 needs to be determined first using [Equation 6](#).

$$R4 = \frac{1.25V}{300\mu A} \quad (6)$$

In the calculation of R4, 300 μ A current is used to achieve sufficient accuracy by taking into account the typical 7.5 μ A soft-start current. For simultaneous tracking R3 is calculated using [Equation 7](#).

$$R3 = \left(1 + \frac{R1}{R2}\right) \times \frac{R4}{1.56} - R4 \quad (7)$$

9.4.6 Short Circuit Protection (Hiccup-Mode)

The device is protected against hard short circuits to GND and over-current events. This is implemented by a two level short circuit protection. During start-up and when the output is shorted to GND the switch current limit is reduced to 1/3 of its typical current limit of 4.6 A. Once the output voltage exceeds typically 0.6 V the current limit is released to its nominal value. The full current limit is implemented as a hiccup current limit. Once the internal current limits is triggered 32 times the device stops switching and starts a new start-up sequence after a typical delay time of 66 μ S passed by. The device will go through these cycles until the high current condition is released.

9.4.7 Output Discharge Function

To make sure the device starts up under defined conditions, the output gets discharged via the VOS pin with a typical discharge resistor of 200 Ω whenever the device shuts down. This happens when the device is disabled or if thermal shutdown, undervoltage lockout or short circuit hiccup-mode is triggered.

10 Application and Implementation

10.1 Application Information

The TPS6209x 3 A family of devices, are high frequency synchronous step down converters optimized for small solution size, high efficiency and suitable for battery powered applications.

10.2 Typical Applications

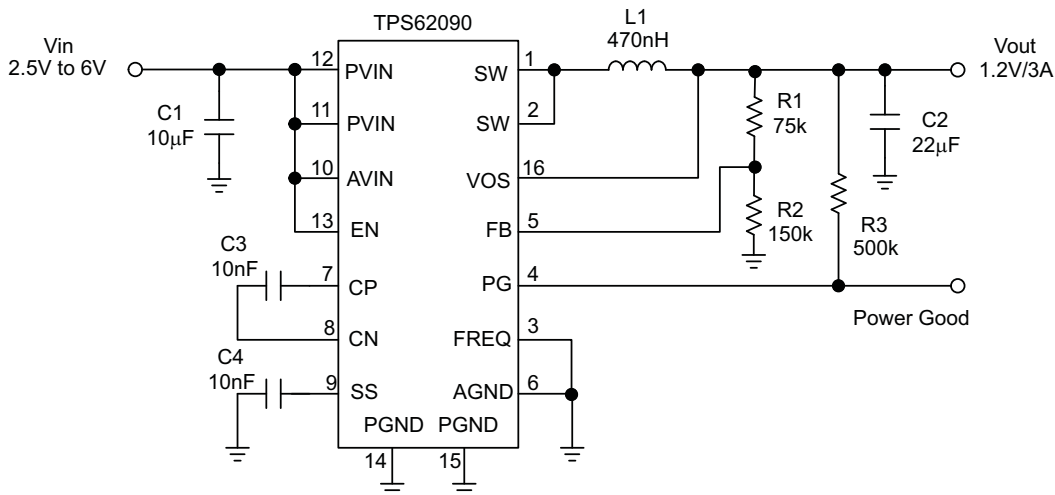

Figure 9. 1.2 V Adjustable Version Operating at 2.8 MHz

10.2.1 Design Requirements

The design can be optimized for highest efficiency or smallest solution size and lowest output voltage ripple. For highest efficiency set the device switching frequency to 1.4 MHz (FREQ=high) and select the output filter components according to Table 4. For smallest solution size and lowest output voltage ripple set the device switching frequency to 2.8 MHz (FREQ=low) and select the output filter components according to Table 3. For the fixed output voltage option the feedback pin needs to be connected to GND.

10.2.2 Detailed Design Procedure

The first step is the selection of the output filter components. To simplify this process, Table 1 and Table 2 outline possible inductor and capacitor value combinations.

Table 1. Output Filter Selection (2.8 MHz Operation, FREQ = GND)

INDUCTOR VALUE [µH] ⁽¹⁾	OUTPUT CAPACITOR VALUE [µF] ⁽²⁾				
	10	22	47	100	150
0.47		√ ⁽³⁾	√	√	√
1.0	√	√	√	√	√
2.2					
3.3					

(1) Inductor tolerance and current de-rating is anticipated. The effective inductance can vary by +20% and -30%.

(2) Capacitance tolerance and bias voltage de-rating is anticipated. The effective capacitance can vary by +20% and -50%.

(3) Typical application configuration. Other check mark indicates alternative filter combinations

Table 2. Output Filter Selection (1.4 MHz Operation, $FREQ = V_{IN}$)

INDUCTOR VALUE [μ H] ⁽¹⁾	OUTPUT CAPACITOR VALUE [μ F] ⁽²⁾				
	10	22	47	100	150
0.47		√	√	√	√
1.0	√	√ ⁽³⁾	√	√	√
2.2	√	√	√	√	√
3.3					

- (1) Inductor tolerance and current de-rating is anticipated. The effective inductance can vary by +20% and –30%.
- (2) Capacitance tolerance and bias voltage de-rating is anticipated. The effective capacitance can vary by +20% and –50%.
- (3) Typical application configuration. Other check mark indicates alternative filter combinations

10.2.2.1 Inductor Selection

The inductor selection is affected by several parameter like inductor ripple current, output voltage ripple, transition point into Power Save Mode, and efficiency. See [Table 3](#) for typical inductors.

Table 3. Inductor Selection

INDUCTOR VALUE	COMPONENT SUPPLIER	SIZE (LxWxH mm)	I _{sat} /DCR
0.6 μ H	Coilcraft XAL4012-601	4 x 4 x 2.1	7.1A/9.5 m Ω
1 μ H	Coilcraft XAL4020-102	4 x 4 x 2.1	5.9A/13.2 m Ω
1 μ H	Coilcraft XFL4020-102	4 x 4 x 2.1	5.1 A/10.8 m Ω
0.47 μ H	TOKO DFE252012 R47	2.5 x 2 x 1.2	3.7A/39 m Ω
1 μ H	TOKO DFE252012 1R0	2.5 x 2 x 1.2	3.0A/59 m Ω
0.68 μ H	TOKO DFE322512 R68	3.2 x 2.5 x 1.2	3.5A/37 m Ω
1 μ H	TOKO DFE322512 1R0	3.2 x 2.5 x 1.2	3.1A/45 m Ω

In addition, the inductor has to be rated for the appropriate saturation current and DC resistance (DCR). The inductor needs to be rated for a saturation current as high as the typical switch current limit, of 4.6 A or according to [Equation 8](#) and [Equation 9](#). [Equation 8](#) and [Equation 9](#) calculate the maximum inductor current under static load conditions. The formula takes the converter efficiency into account. The converter efficiency can be taken from the data sheet graph's or 80% can be used as a conservative approach. The calculation must be done for the maximum input voltage where the peak switch current is highest.

$$I_L = I_{OUT} + \frac{\Delta I_L}{2} \quad (8)$$

$$I_L = I_{OUT} + \frac{V_{OUT}}{\eta} \times \left(1 - \frac{V_{OUT}}{V_{IN} \times \eta} \right) \quad (9)$$

where

f = Converter switching frequency (typical 2.8 MHz or 1.4 MHz)

L = Selected inductor value

η = Estimated converter efficiency (use the number from the efficiency curves or 0.80 as an conservative assumption)

Note: The calculation must be done for the maximum input voltage of the application

Calculating the maximum inductor current using the actual operating conditions gives the minimum saturation current. A margin of 20% needs to be added to cover for load transients during operation.

10.2.2.2 Input and Output Capacitor Selection

For best output and input voltage filtering, low ESR ceramic capacitors are recommended. The input capacitor minimizes input voltage ripple, suppresses input voltage spikes and provides a stable system rail for the device. A 22 μF or larger input capacitor is recommended for 1.4 MHz operation frequency. For 2.8 MHz operation frequency a 10 μF input capacitor or larger is recommended. The output capacitor value can range from 10 μF up to 150 μF and beyond. The recommended typical output capacitor value is 22 μF and can vary over a wide range as outline in the output filter selection table.

Table 4. Input Capacitor Selection

INPUT CAPACITOR	COMMENT
10 μF	FREQ=low, f=2.8 MHz
22 μF	FREQ=high, f=1.4 MHz

10.2.2.3 Setting the Output Voltage

The output voltage is set by an external resistor divider according to the following equations:

$$V_{\text{OUT}} = V_{\text{FB}} \times \left(1 + \frac{R1}{R2} \right) = 0.8 \text{ V} \times \left(1 + \frac{R1}{R2} \right) \quad (10)$$

$$R2 = \frac{V_{\text{FB}}}{I_{\text{FB}}} = \frac{0.8 \text{ V}}{5 \mu\text{A}} \approx 160 \text{ k}\Omega \quad (11)$$

$$R1 = R2 \times \left(\frac{V_{\text{OUT}}}{V_{\text{FB}}} - 1 \right) = R2 \times \left(\frac{V_{\text{OUT}}}{0.8\text{V}} - 1 \right) \quad (12)$$

When sizing R2, in order to achieve low quiescent current and acceptable noise sensitivity, use a minimum of 5 μA for the feedback current I_{FB} . Larger currents through R2 improve noise sensitivity and output voltage accuracy. Lowest quiescent current and best output voltage accuracy can be achieved with the fixed output voltage versions. For the fixed output voltage versions, the FB pin can be left floating or connected to GND to improve the thermal package performance.

10.2.2.4 Application Curves

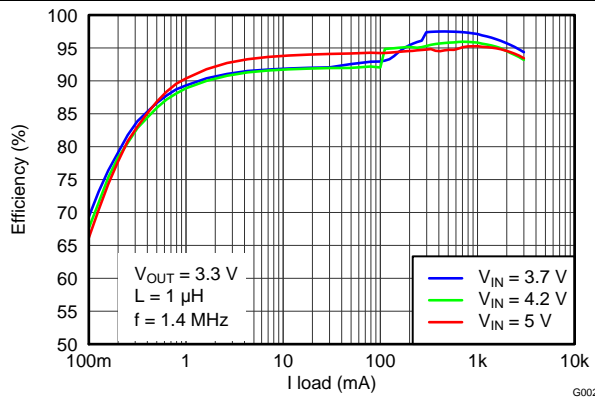

Figure 10. Efficiency vs Load Current

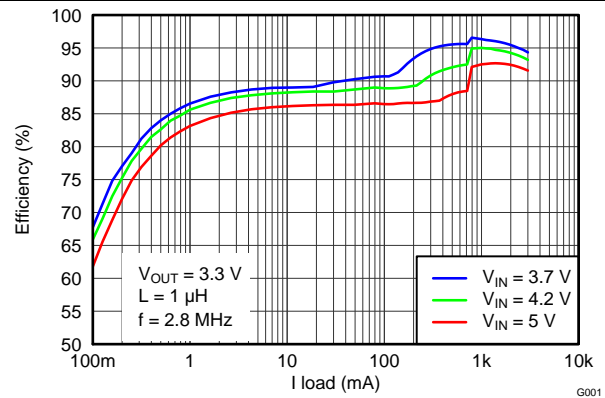

Figure 11. Efficiency vs Load Current

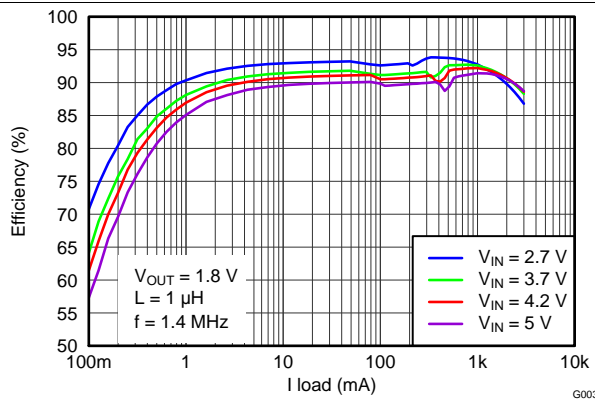

Figure 12. Efficiency vs Load Current

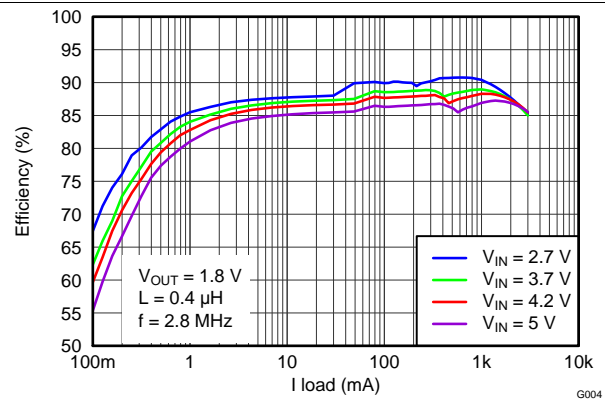

Figure 13. Efficiency vs Load Current

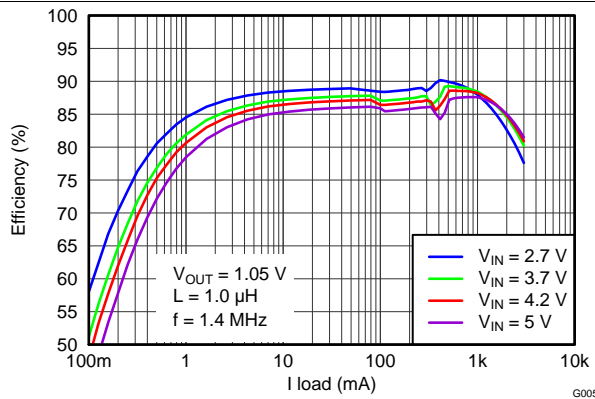

Figure 14. Efficiency vs Load Current

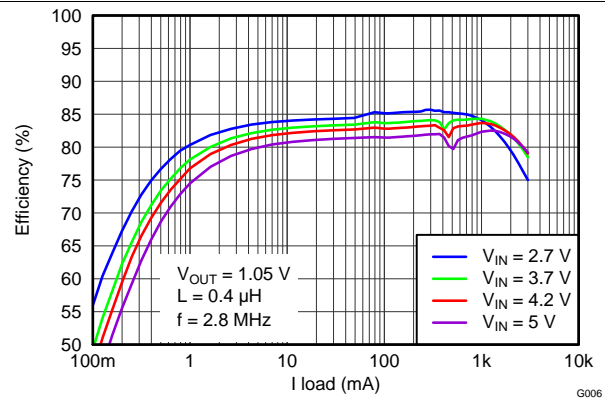

Figure 15. Efficiency vs Load Current

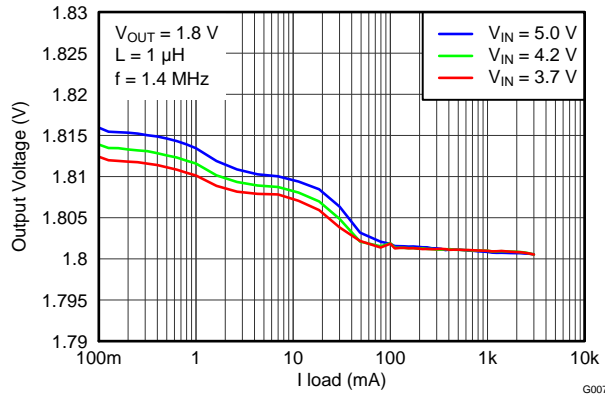

Figure 16. Output Voltage vs Load Current

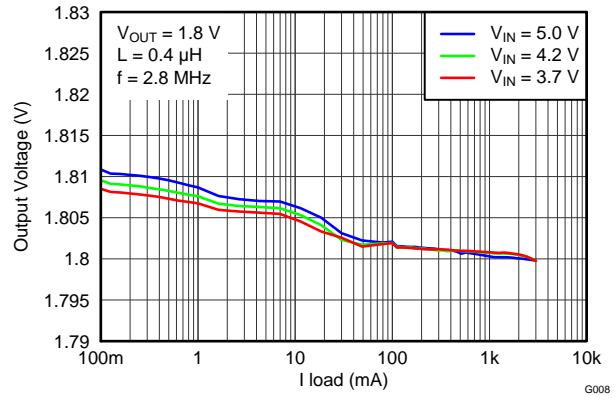

Figure 17. Output Voltage vs Load Current

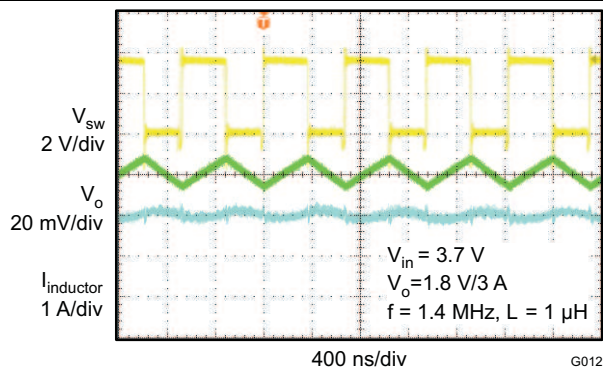

Figure 18. PWM Operation

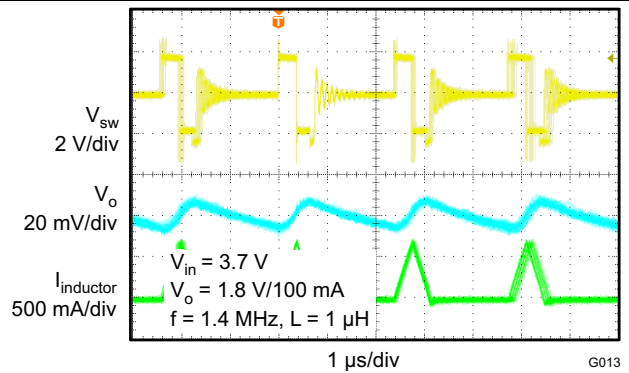

Figure 19. PFM Operation

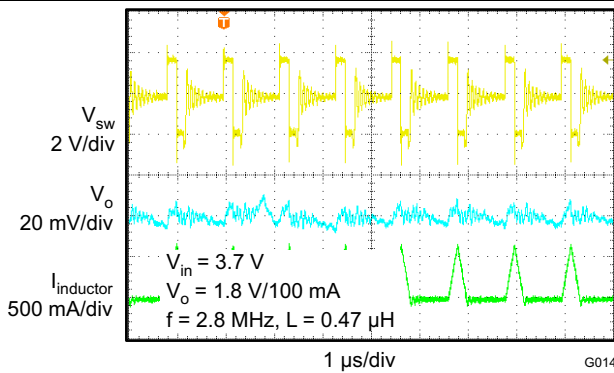

Figure 20. PFM Operation

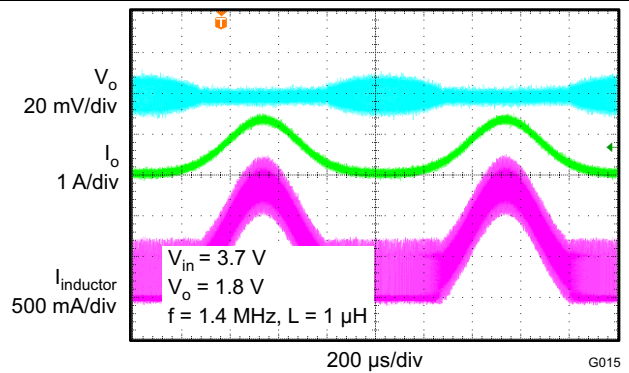

Figure 21. Load Sweep

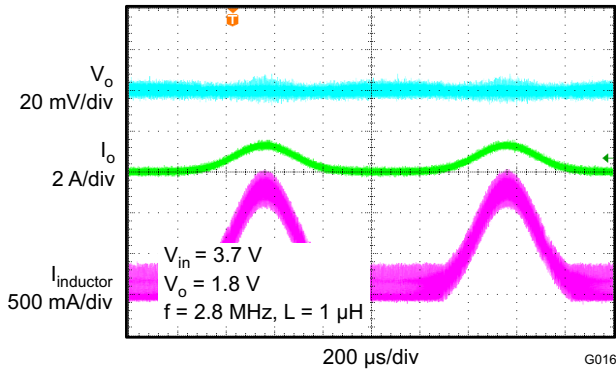

Figure 22. Load Sweep

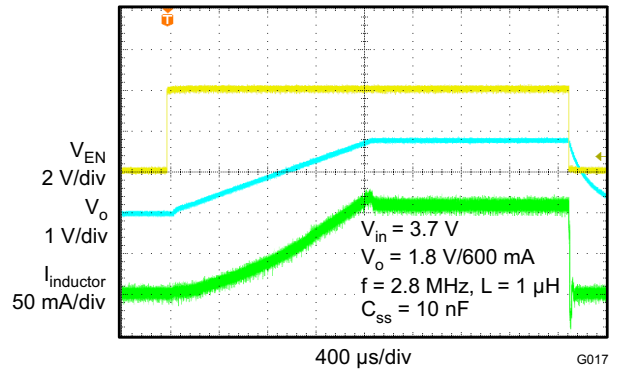

Figure 23. Start-Up

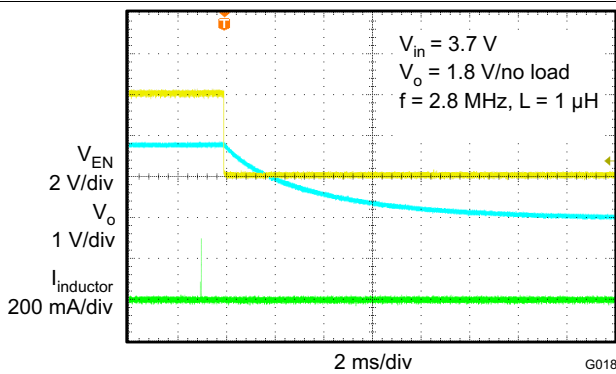

Figure 24. Shutdown

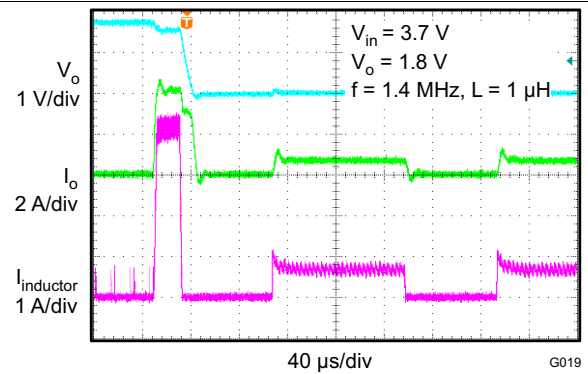

Figure 25. Hiccup Short Circuit Protection

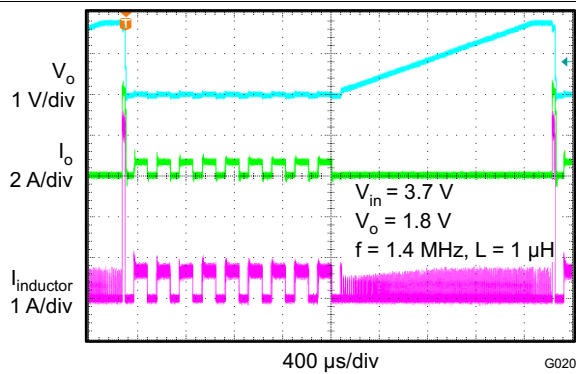

Figure 26. Hiccup Short Circuit Protection

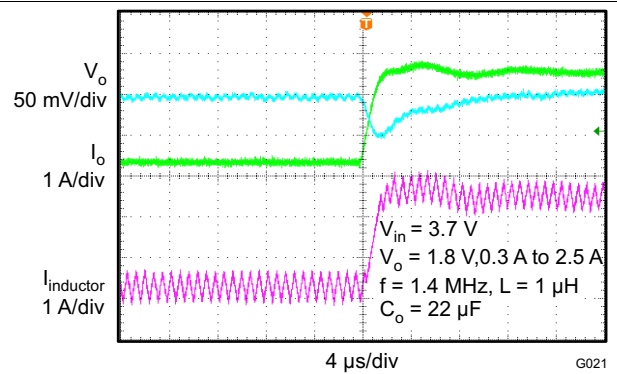
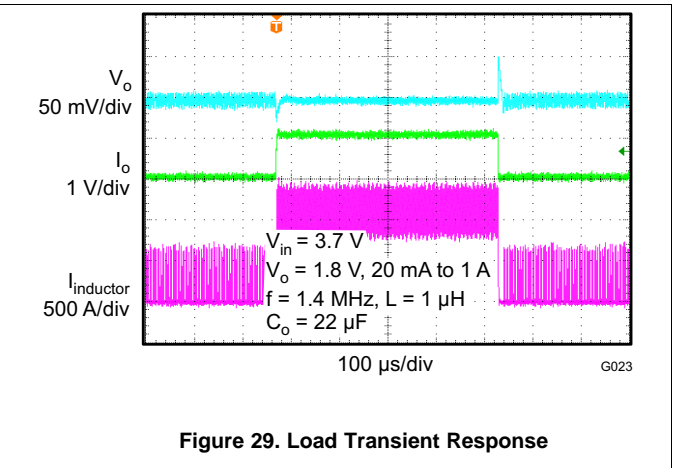
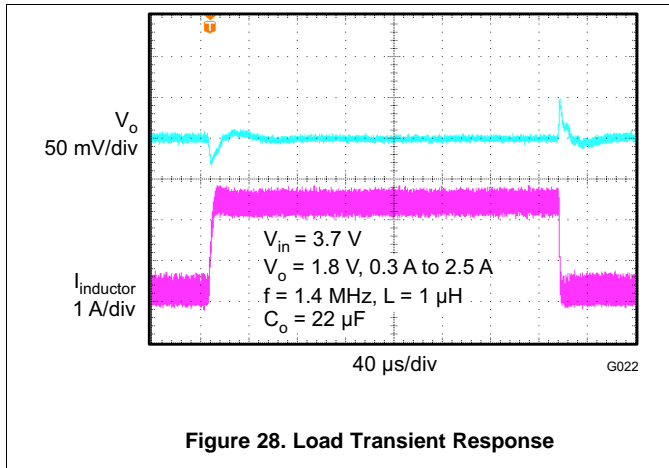

Figure 27. Load Transient Response



11 Power Supply Recommendations

The power supply to the TPS62090 needs to have a current rating according to the supply voltage, output voltage and output current of the TPS62090.

12 Layout

12.1 Layout Guideline

- It is recommended to place the input capacitor as close as possible to the IC pins PVIN and PGND.
- The VOS connection is noise sensitive and needs to be routed as short and directly to the output pin of the inductor.
- The exposed thermal pad of the package, analog ground (pin 6) and power ground (pin 14, 15) should have a single joint connection at the exposed thermal pad of the package.
- This minimizes switch node jitter. The charge pump capacitor connected to CP and CN should be placed close to the IC to minimize coupling of switching waveforms into other traces and circuits.
- Refer to the evaluation module User Guide ([SLVU670](#)) for an example of component placement, routing and thermal design.

12.2 Layout Example

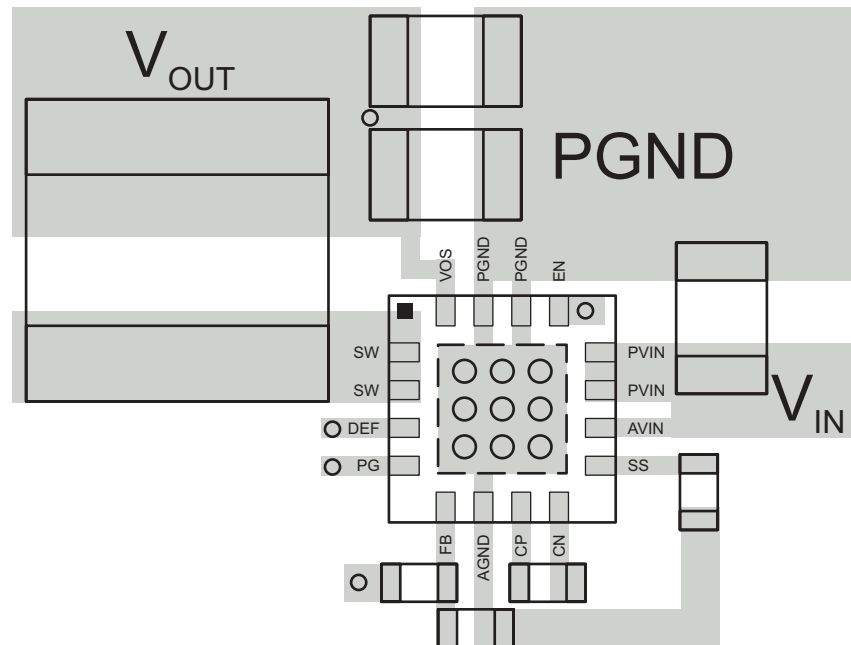

Figure 30. TPS6209x Layout

13 Device and Documentation Support

13.1 Device Support

13.1.1 Third-Party Products Disclaimer

TI'S PUBLICATION OF INFORMATION REGARDING THIRD-PARTY PRODUCTS OR SERVICES DOES NOT CONSTITUTE AN ENDORSEMENT REGARDING THE SUITABILITY OF SUCH PRODUCTS OR SERVICES OR A WARRANTY, REPRESENTATION OR ENDORSEMENT OF SUCH PRODUCTS OR SERVICES, EITHER ALONE OR IN COMBINATION WITH ANY TI PRODUCT OR SERVICE.

13.2 Related Links

The table below lists quick access links. Categories include technical documents, support and community resources, tools and software, and quick access to sample or buy.

Table 5. Related Links

PARTS	PRODUCT FOLDER	SAMPLE & BUY	TECHNICAL DOCUMENTS	TOOLS & SOFTWARE	SUPPORT & COMMUNITY
TPS62090	Click here	Click here	Click here	Click here	Click here
TPS62091	Click here	Click here	Click here	Click here	Click here
TPS62092	Click here	Click here	Click here	Click here	Click here
TPS62093	Click here	Click here	Click here	Click here	Click here

13.3 Trademarks

All trademarks are the property of their respective owners.

13.4 Electrostatic Discharge Caution



These devices have limited built-in ESD protection. The leads should be shorted together or the device placed in conductive foam during storage or handling to prevent electrostatic damage to the MOS gates.

13.5 Glossary

[SLYZ022](#) — *TI Glossary*.

This glossary lists and explains terms, acronyms and definitions.

14 Mechanical, Packaging, and Orderable Information

The following pages include mechanical, packaging, and orderable information. This information is the most current data available for the designated devices. This data is subject to change without notice and revision of this document. For browser-based versions of this data sheet, refer to the left-hand navigation.

PACKAGING INFORMATION

Orderable Device	Status (1)	Package Type	Package Drawing	Pins	Package Qty	Eco Plan (2)	Lead/Ball Finish (6)	MSL Peak Temp (3)	Op Temp (°C)	Device Marking (4/5)	Samples
TPS62090RGTR	ACTIVE	QFN	RGT	16	3000	Green (RoHS & no Sb/Br)	CU NIPDAU	Level-2-260C-1 YEAR	-40 to 85	SBW	Samples
TPS62090RGTT	ACTIVE	QFN	RGT	16	250	Green (RoHS & no Sb/Br)	CU NIPDAU	Level-2-260C-1 YEAR	-40 to 85	SBW	Samples
TPS62091RGTR	ACTIVE	QFN	RGT	16	3000	Green (RoHS & no Sb/Br)	CU NIPDAU	Level-2-260C-1 YEAR	-40 to 85	SBX	Samples
TPS62091RGTT	ACTIVE	QFN	RGT	16	250	Green (RoHS & no Sb/Br)	CU NIPDAU	Level-2-260C-1 YEAR	-40 to 85	SBX	Samples
TPS62092RGTR	ACTIVE	QFN	RGT	16	3000	Green (RoHS & no Sb/Br)	CU NIPDAU	Level-2-260C-1 YEAR	-40 to 85	SBY	Samples
TPS62092RGTT	ACTIVE	QFN	RGT	16	250	Green (RoHS & no Sb/Br)	CU NIPDAU	Level-2-260C-1 YEAR	-40 to 85	SBY	Samples
TPS62093RGTR	ACTIVE	QFN	RGT	16	3000	Green (RoHS & no Sb/Br)	CU NIPDAU	Level-2-260C-1 YEAR	-40 to 85	SBZ	Samples
TPS62093RGTT	ACTIVE	QFN	RGT	16	250	Green (RoHS & no Sb/Br)	CU NIPDAU	Level-2-260C-1 YEAR	-40 to 85	SBZ	Samples

(1) The marketing status values are defined as follows:

ACTIVE: Product device recommended for new designs.

LIFEBUY: TI has announced that the device will be discontinued, and a lifetime-buy period is in effect.

NRND: Not recommended for new designs. Device is in production to support existing customers, but TI does not recommend using this part in a new design.

PREVIEW: Device has been announced but is not in production. Samples may or may not be available.

OBSOLETE: TI has discontinued the production of the device.

(2) Eco Plan - The planned eco-friendly classification: Pb-Free (RoHS), Pb-Free (RoHS Exempt), or Green (RoHS & no Sb/Br) - please check <http://www.ti.com/productcontent> for the latest availability information and additional product content details.

TBD: The Pb-Free/Green conversion plan has not been defined.

Pb-Free (RoHS): TI's terms "Lead-Free" or "Pb-Free" mean semiconductor products that are compatible with the current RoHS requirements for all 6 substances, including the requirement that lead not exceed 0.1% by weight in homogeneous materials. Where designed to be soldered at high temperatures, TI Pb-Free products are suitable for use in specified lead-free processes.

Pb-Free (RoHS Exempt): This component has a RoHS exemption for either 1) lead-based flip-chip solder bumps used between the die and package, or 2) lead-based die adhesive used between the die and leadframe. The component is otherwise considered Pb-Free (RoHS compatible) as defined above.

Green (RoHS & no Sb/Br): TI defines "Green" to mean Pb-Free (RoHS compatible), and free of Bromine (Br) and Antimony (Sb) based flame retardants (Br or Sb do not exceed 0.1% by weight in homogeneous material)

(3) MSL, Peak Temp. - The Moisture Sensitivity Level rating according to the JEDEC industry standard classifications, and peak solder temperature.

(4) There may be additional marking, which relates to the logo, the lot trace code information, or the environmental category on the device.

(5) Multiple Device Markings will be inside parentheses. Only one Device Marking contained in parentheses and separated by a "~" will appear on a device. If a line is indented then it is a continuation of the previous line and the two combined represent the entire Device Marking for that device.

(6) Lead/Ball Finish - Orderable Devices may have multiple material finish options. Finish options are separated by a vertical ruled line. Lead/Ball Finish values may wrap to two lines if the finish value exceeds the maximum column width.

Important Information and Disclaimer:The information provided on this page represents TI's knowledge and belief as of the date that it is provided. TI bases its knowledge and belief on information provided by third parties, and makes no representation or warranty as to the accuracy of such information. Efforts are underway to better integrate information from third parties. TI has taken and continues to take reasonable steps to provide representative and accurate information but may not have conducted destructive testing or chemical analysis on incoming materials and chemicals. TI and TI suppliers consider certain information to be proprietary, and thus CAS numbers and other limited information may not be available for release.

In no event shall TI's liability arising out of such information exceed the total purchase price of the TI part(s) at issue in this document sold by TI to Customer on an annual basis.

OTHER QUALIFIED VERSIONS OF TPS62090 :

- Automotive: [TPS62090-Q1](#)

NOTE: Qualified Version Definitions:

- Automotive - Q100 devices qualified for high-reliability automotive applications targeting zero defects

TAPE AND REEL INFORMATION

QUADRANT ASSIGNMENTS FOR PIN 1 ORIENTATION IN TAPE

*All dimensions are nominal

Device	Package Type	Package Drawing	Pins	SPQ	Reel Diameter (mm)	Reel Width W1 (mm)	A0 (mm)	B0 (mm)	K0 (mm)	P1 (mm)	W (mm)	Pin1 Quadrant
TPS62090RGTR	QFN	RGT	16	3000	330.0	12.4	3.3	3.3	1.1	8.0	12.0	Q2
TPS62090RGTT	QFN	RGT	16	250	180.0	12.4	3.3	3.3	1.1	8.0	12.0	Q2
TPS62091RGTR	QFN	RGT	16	3000	330.0	12.4	3.3	3.3	1.1	8.0	12.0	Q2
TPS62091RGTT	QFN	RGT	16	250	180.0	12.5	3.3	3.3	1.1	8.0	12.0	Q2
TPS62092RGTR	QFN	RGT	16	3000	330.0	12.4	3.3	3.3	1.1	8.0	12.0	Q2
TPS62092RGTT	QFN	RGT	16	250	180.0	12.5	3.3	3.3	1.1	8.0	12.0	Q2
TPS62093RGTR	QFN	RGT	16	3000	330.0	12.4	3.3	3.3	1.1	8.0	12.0	Q2
TPS62093RGTT	QFN	RGT	16	250	180.0	12.5	3.3	3.3	1.1	8.0	12.0	Q2

TAPE AND REEL BOX DIMENSIONS

*All dimensions are nominal

Device	Package Type	Package Drawing	Pins	SPQ	Length (mm)	Width (mm)	Height (mm)
TPS62090RGTR	QFN	RGT	16	3000	367.0	367.0	35.0
TPS62090RGTT	QFN	RGT	16	250	210.0	185.0	35.0
TPS62091RGTR	QFN	RGT	16	3000	338.0	355.0	50.0
TPS62091RGTT	QFN	RGT	16	250	338.0	355.0	50.0
TPS62092RGTR	QFN	RGT	16	3000	338.0	355.0	50.0
TPS62092RGTT	QFN	RGT	16	250	338.0	355.0	50.0
TPS62093RGTR	QFN	RGT	16	3000	338.0	355.0	50.0
TPS62093RGTT	QFN	RGT	16	250	338.0	355.0	50.0

RGT (S-PVQFN-N16)

PLASTIC QUAD FLATPACK NO-LEAD

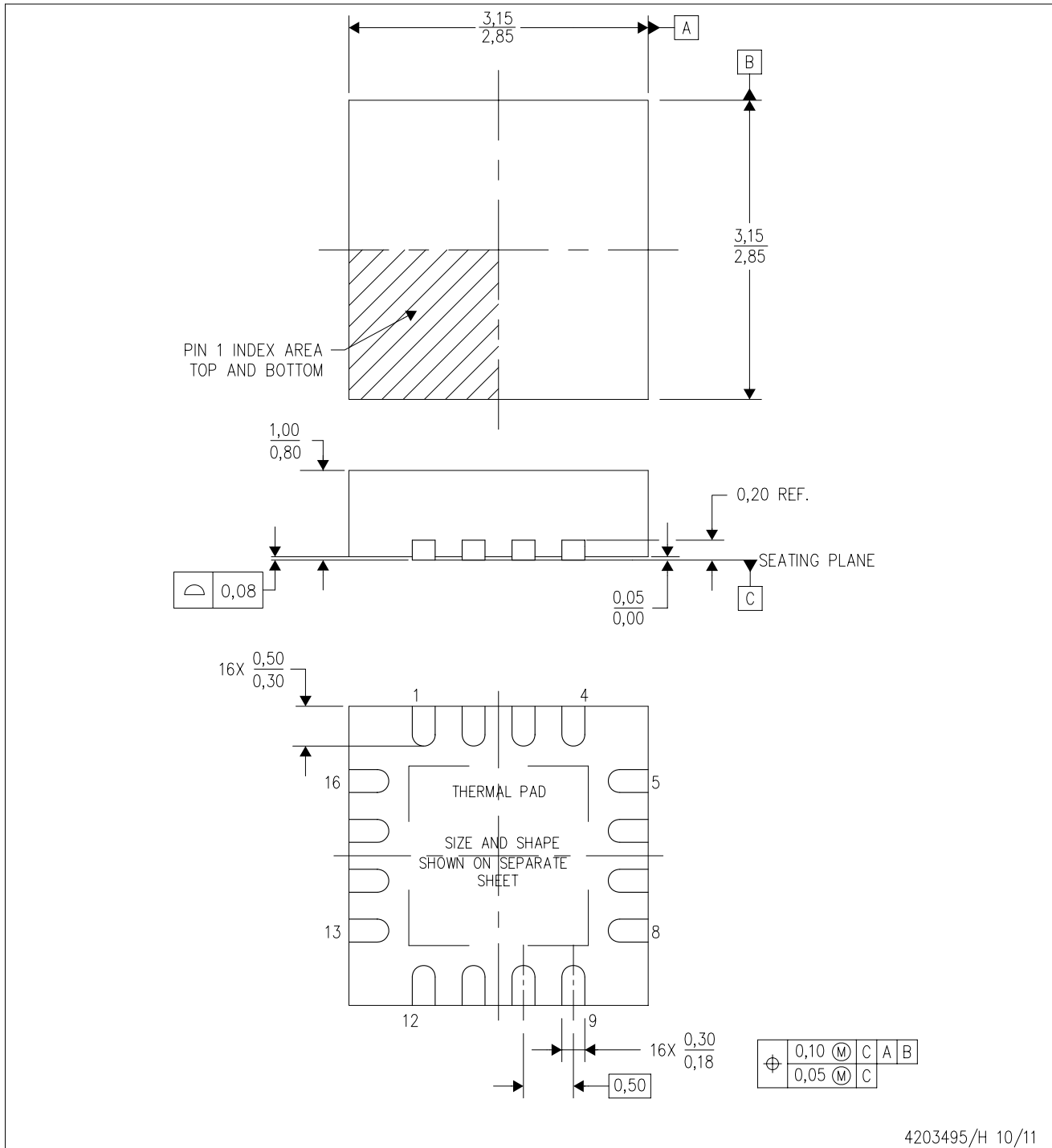

4203495/H 10/11

- NOTES:
- All linear dimensions are in millimeters. Dimensioning and tolerancing per ASME Y14.5M-1994.
 - This drawing is subject to change without notice.
 - Quad Flatpack, No-leads (QFN) package configuration.
 - The package thermal pad must be soldered to the board for thermal and mechanical performance.
 - See the additional figure in the Product Data Sheet for details regarding the exposed thermal pad features and dimensions.
 - Falls within JEDEC MO-220.

THERMAL PAD MECHANICAL DATA

RGT (S-PVQFN-N16)

PLASTIC QUAD FLATPACK NO-LEAD

THERMAL INFORMATION

This package incorporates an exposed thermal pad that is designed to be attached directly to an external heatsink. The thermal pad must be soldered directly to the printed circuit board (PCB). After soldering, the PCB can be used as a heatsink. In addition, through the use of thermal vias, the thermal pad can be attached directly to the appropriate copper plane shown in the electrical schematic for the device, or alternatively, can be attached to a special heatsink structure designed into the PCB. This design optimizes the heat transfer from the integrated circuit (IC).

For information on the Quad Flatpack No-Lead (QFN) package and its advantages, refer to Application Report, QFN/SON PCB Attachment, Texas Instruments Literature No. SLUA271. This document is available at www.ti.com.

The exposed thermal pad dimensions for this package are shown in the following illustration.

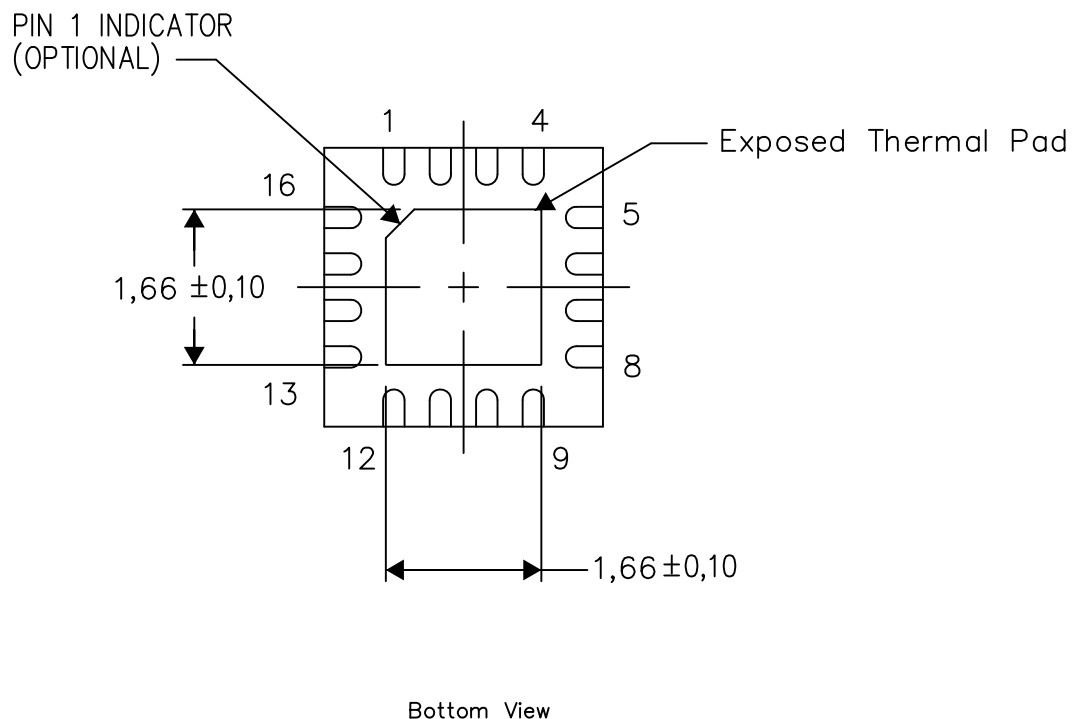

Exposed Thermal Pad Dimensions

4206349-10/Z 08/15

NOTE: All linear dimensions are in millimeters

RGT (S-PVQFN-N16)

PLASTIC QUAD FLATPACK NO-LEAD

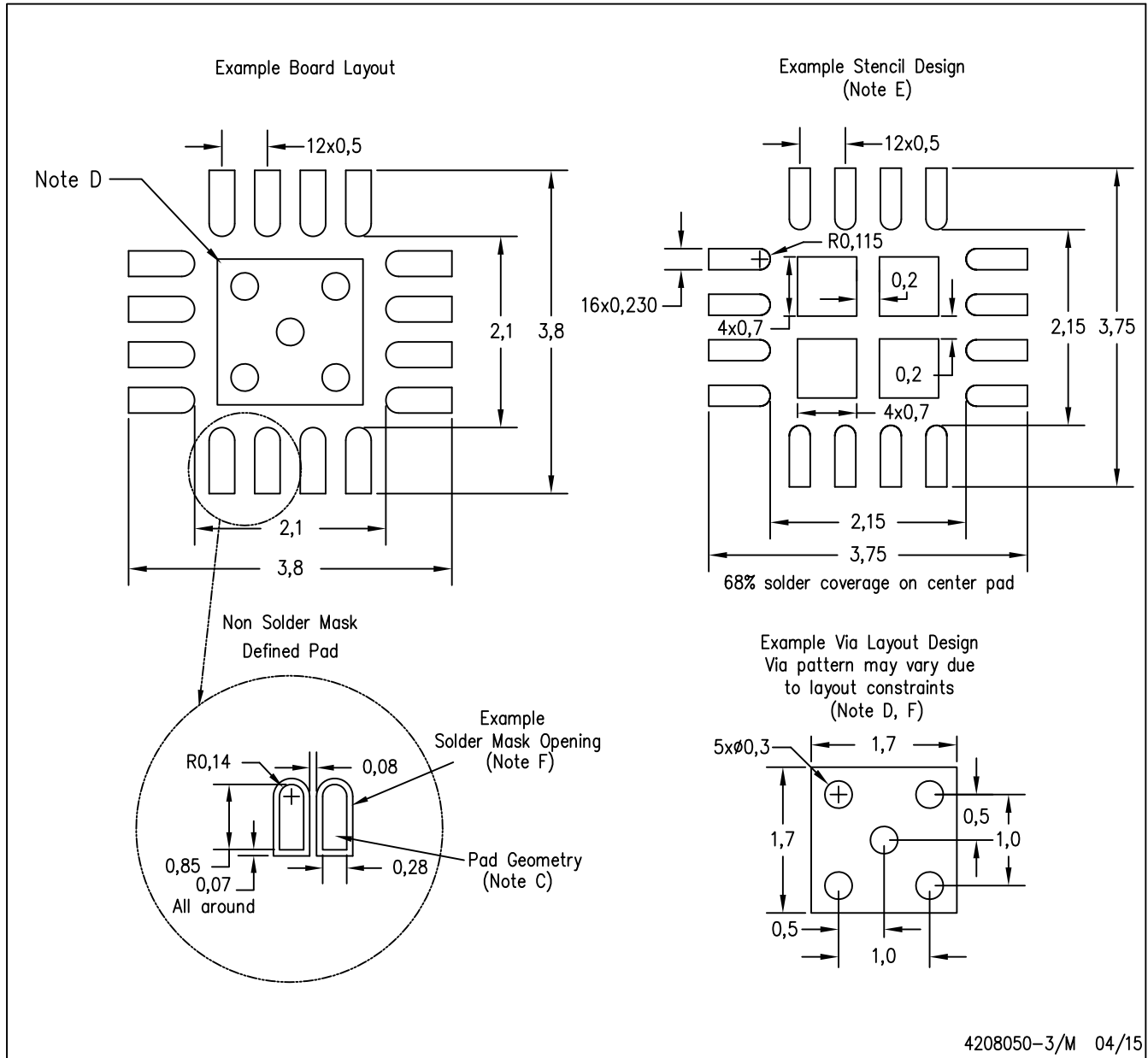

- NOTES:
- A. All linear dimensions are in millimeters.
 - B. This drawing is subject to change without notice.
 - C. Publication IPC-7351 is recommended for alternate designs.
 - D. This package is designed to be soldered to a thermal pad on the board. Refer to Application Note, QFN/SON PCB Attachment, Texas Instruments Literature No. SLUA271, and also the Product Data Sheets for specific thermal information, via requirements, and recommended board layout. These documents are available at www.ti.com <<http://www.ti.com>>.
 - E. Laser cutting apertures with trapezoidal walls and also rounding corners will offer better paste release. Customers should contact their board assembly site for stencil design recommendations. Refer to IPC 7525 for stencil design considerations.
 - F. Customers should contact their board fabrication site for minimum solder mask web tolerances between signal pads.

IMPORTANT NOTICE

Texas Instruments Incorporated and its subsidiaries (TI) reserve the right to make corrections, enhancements, improvements and other changes to its semiconductor products and services per JESD46, latest issue, and to discontinue any product or service per JESD48, latest issue. Buyers should obtain the latest relevant information before placing orders and should verify that such information is current and complete. All semiconductor products (also referred to herein as "components") are sold subject to TI's terms and conditions of sale supplied at the time of order acknowledgment.

TI warrants performance of its components to the specifications applicable at the time of sale, in accordance with the warranty in TI's terms and conditions of sale of semiconductor products. Testing and other quality control techniques are used to the extent TI deems necessary to support this warranty. Except where mandated by applicable law, testing of all parameters of each component is not necessarily performed.

TI assumes no liability for applications assistance or the design of Buyers' products. Buyers are responsible for their products and applications using TI components. To minimize the risks associated with Buyers' products and applications, Buyers should provide adequate design and operating safeguards.

TI does not warrant or represent that any license, either express or implied, is granted under any patent right, copyright, mask work right, or other intellectual property right relating to any combination, machine, or process in which TI components or services are used. Information published by TI regarding third-party products or services does not constitute a license to use such products or services or a warranty or endorsement thereof. Use of such information may require a license from a third party under the patents or other intellectual property of the third party, or a license from TI under the patents or other intellectual property of TI.

Reproduction of significant portions of TI information in TI data books or data sheets is permissible only if reproduction is without alteration and is accompanied by all associated warranties, conditions, limitations, and notices. TI is not responsible or liable for such altered documentation. Information of third parties may be subject to additional restrictions.

Resale of TI components or services with statements different from or beyond the parameters stated by TI for that component or service voids all express and any implied warranties for the associated TI component or service and is an unfair and deceptive business practice. TI is not responsible or liable for any such statements.

Buyer acknowledges and agrees that it is solely responsible for compliance with all legal, regulatory and safety-related requirements concerning its products, and any use of TI components in its applications, notwithstanding any applications-related information or support that may be provided by TI. Buyer represents and agrees that it has all the necessary expertise to create and implement safeguards which anticipate dangerous consequences of failures, monitor failures and their consequences, lessen the likelihood of failures that might cause harm and take appropriate remedial actions. Buyer will fully indemnify TI and its representatives against any damages arising out of the use of any TI components in safety-critical applications.

In some cases, TI components may be promoted specifically to facilitate safety-related applications. With such components, TI's goal is to help enable customers to design and create their own end-product solutions that meet applicable functional safety standards and requirements. Nonetheless, such components are subject to these terms.

No TI components are authorized for use in FDA Class III (or similar life-critical medical equipment) unless authorized officers of the parties have executed a special agreement specifically governing such use.

Only those TI components which TI has specifically designated as military grade or "enhanced plastic" are designed and intended for use in military/aerospace applications or environments. Buyer acknowledges and agrees that any military or aerospace use of TI components which have **not** been so designated is solely at the Buyer's risk, and that Buyer is solely responsible for compliance with all legal and regulatory requirements in connection with such use.

TI has specifically designated certain components as meeting ISO/TS16949 requirements, mainly for automotive use. In any case of use of non-designated products, TI will not be responsible for any failure to meet ISO/TS16949.

Products

Audio	www.ti.com/audio
Amplifiers	amplifier.ti.com
Data Converters	dataconverter.ti.com
DLP® Products	www.dlp.com
DSP	dsp.ti.com
Clocks and Timers	www.ti.com/clocks
Interface	interface.ti.com
Logic	logic.ti.com
Power Mgmt	power.ti.com
Microcontrollers	microcontroller.ti.com
RFID	www.ti-rfid.com
OMAP Applications Processors	www.ti.com/omap
Wireless Connectivity	www.ti.com/wirelessconnectivity

Applications

Automotive and Transportation	www.ti.com/automotive
Communications and Telecom	www.ti.com/communications
Computers and Peripherals	www.ti.com/computers
Consumer Electronics	www.ti.com/consumer-apps
Energy and Lighting	www.ti.com/energy
Industrial	www.ti.com/industrial
Medical	www.ti.com/medical
Security	www.ti.com/security
Space, Avionics and Defense	www.ti.com/space-avionics-defense
Video and Imaging	www.ti.com/video

TI E2E Community

e2e.ti.com