

TPS75515, TPS75518, TPS75525, TPS75533 WITH POWER GOOD AND TPS75501 FAST-TRANSIENT RESPONSE 5-A LOW-DROPOUT VOLTAGE REGULATORS

SLVS293D – NOVEMBER 2000 – REVISED MAY 2002

- 5-A Low-Dropout Voltage Regulator
- Available in 1.5-V, 1.8-V, 2.5-V, and 3.3-V Fixed-Output and Adjustable Versions
- Open Drain Power-Good ($\overline{\text{PG}}$) Status Output (Fixed Options Only)
- Dropout Voltage Typically 250 mV at 5 A (TPS75533)
- Low 125 μA Typical Quiescent Current
- Fast Transient Response
- 3% Tolerance Over Specified Conditions for Fixed-Output Versions
- Available in 5-Pin TO-220 and TO-263 Surface-Mount Packages
- Thermal Shutdown Protection

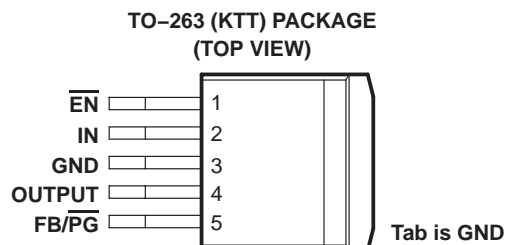
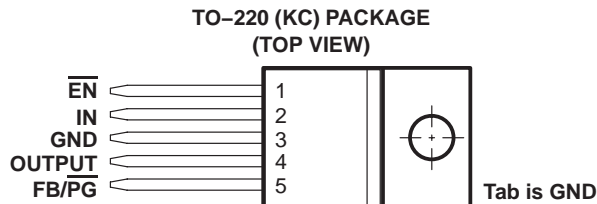

description

The TPS755xx family of 5-A low dropout (LDO) regulators contains four fixed voltage option regulators with integrated power-good (PG) and an adjustable voltage option regulator. These devices are capable of supplying 5 A of output current with a dropout of 250 mV (TPS75533). Therefore, the device is capable of performing a 3.3-V to 2.5-V conversion. Quiescent current is 125 μA at full load and drops down to less than 1 μA when the device is disabled. The TPS755xx is designed to have fast transient response for large load current changes.

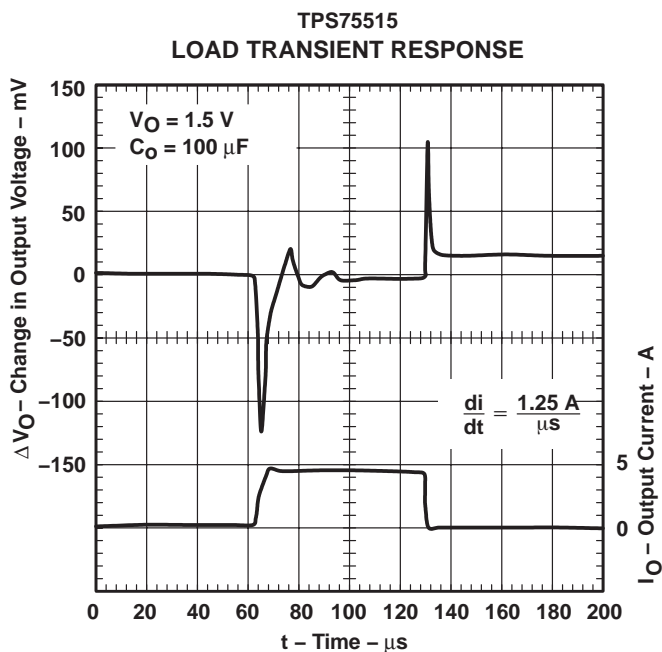
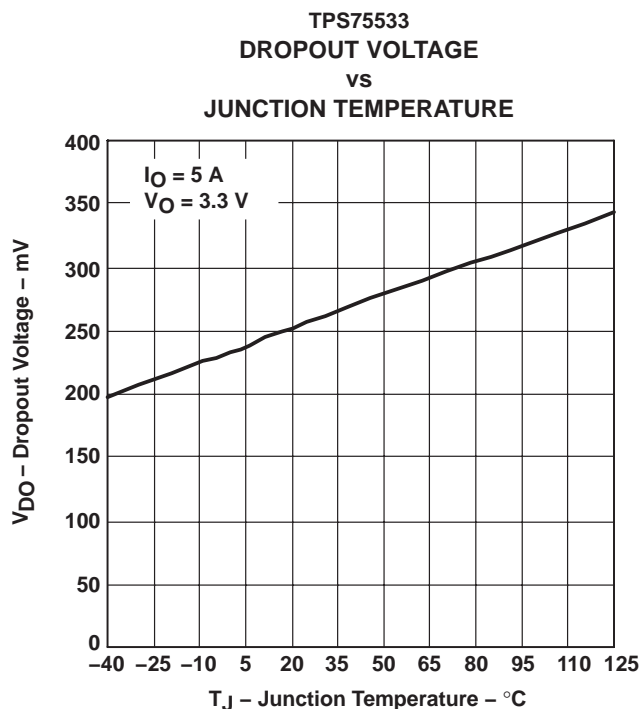

TPS75515, TPS75518, TPS75525, TPS75533 WITH POWER GOOD AND TPS75501 FAST-TRANSIENT RESPONSE 5-A LOW-DROPOUT VOLTAGE REGULATORS

SLVS293D – NOVEMBER 2000 – REVISED MAY 2002

description (continued)

Because the PMOS device behaves as a low-value resistor, the dropout voltage is very low (typically 250 mV at an output current of 5 A for the TPS75533) and is directly proportional to the output current. Additionally, since the PMOS pass element is a voltage-driven device, the quiescent current is very low and independent of output loading (typically 125 μA over the full range of output current). These two key specifications yield a significant improvement in operating life for battery-powered systems.

The device is enabled when $\overline{\text{EN}}$ is connected to a low-level voltage. This LDO family also features a sleep mode; applying a TTL high signal to $\overline{\text{EN}}$ (enable) shuts down the regulator, reducing the quiescent current to less than 1 μA at $T_J = 25^\circ\text{C}$. The power-good terminal ($\overline{\text{PG}}$) is an active low, open drain output, which can be used to implement a power-on reset or a low-battery indicator.

The TPS755xx is offered in 1.5-V, 1.8-V, 2.5-V, and 3.3-V fixed-voltage versions and in an adjustable version (programmable over the range of 1.22 V to 5 V). Output voltage tolerance is specified as a maximum of 3% over line, load, and temperature ranges. The TPS755xx family is available in a 5-pin TO-220 (KC) and TO-263 (KTT) packages.

AVAILABLE OPTIONS

T_J	OUTPUT VOLTAGE (TYP)	TO-220 (KC)	TO-263(KTT)
-40°C to 125°C	3.3 V	TPS75533KC	TPS75533KTT
	2.5 V	TPS75525KC	TPS75525KTT
	1.8 V	TPS75518KC	TPS75518KTT
	1.5 V	TPS75515KC	TPS75515KTT
	Adjustable 1.22 V to 5 V	TPS75501KC	TPS75501KTT

NOTE: The TPS75501 is programmable using an external resistor divider (see application information). The KTT package is available taped and reeled. Add an R suffix to the device type (e.g., TPS75501KTTR) to indicate tape and reel.

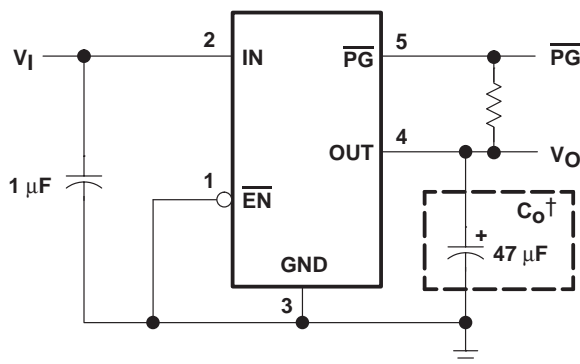

† See application information section for capacitor selection details.

Figure 1. Typical Application Configuration (For Fixed Output Options)

TPS75515, TPS75518, TPS75525, TPS75533 WITH POWER GOOD AND TPS75501 FAST-TRANSIENT RESPONSE 5-A LOW-DROPOUT VOLTAGE REGULATORS

SLVS293D – NOVEMBER 2000 – REVISED MAY 2002

functional block diagram—adjustable version

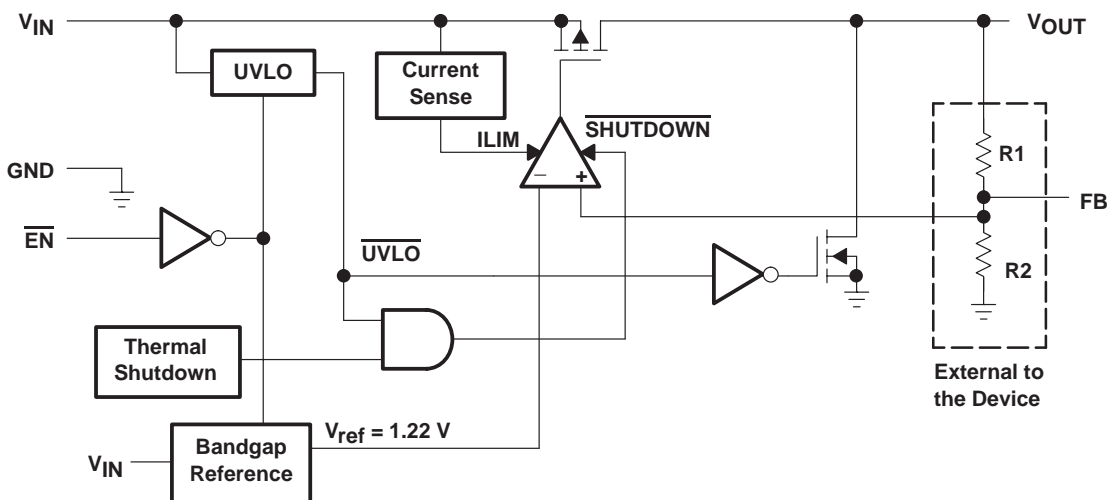

functional block diagram—fixed version

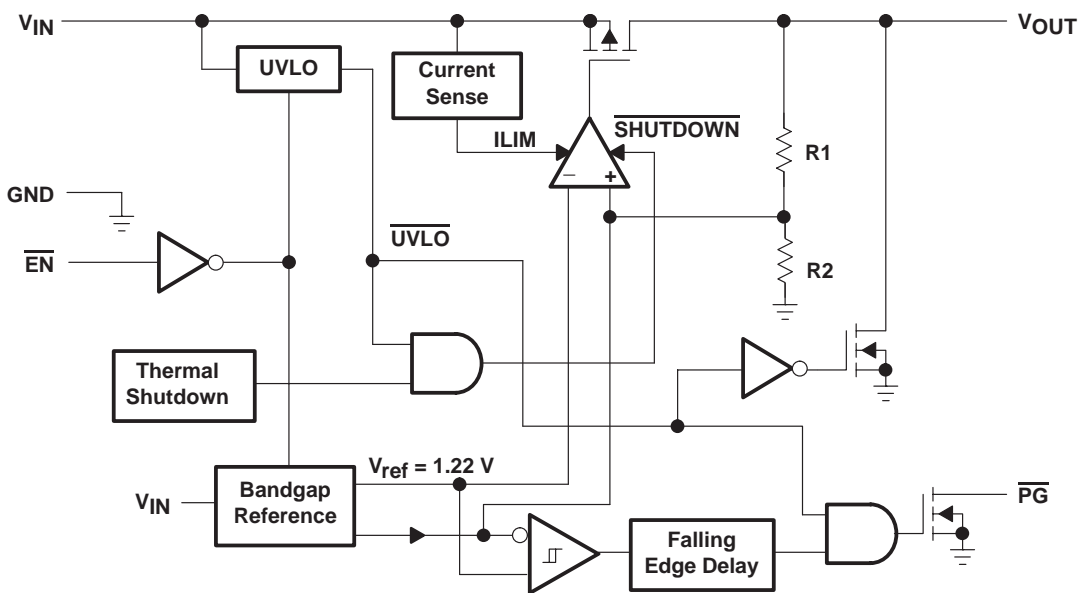

Terminal Functions (TPS755xx)

TERMINAL NAME	NO.	I/O	DESCRIPTION
$\overline{\text{EN}}$	1	I	Enable input
$\text{FB}/\overline{\text{PG}}$	5	I	Feedback input voltage for adjustable device/ $\overline{\text{PG}}$ output for fixed options
GND	3		Regulator ground
IN	2	I	Input voltage
OUTPUT	4	O	Regulated output voltage

TPS75515, TPS75518, TPS75525, TPS75533 WITH POWER GOOD AND TPS75501 FAST-TRANSIENT RESPONSE 5-A LOW-DROPOUT VOLTAGE REGULATORS

SLVS293D – NOVEMBER 2000 – REVISED MAY 2002

TPS755xx $\overline{\text{PG}}$ timing diagram

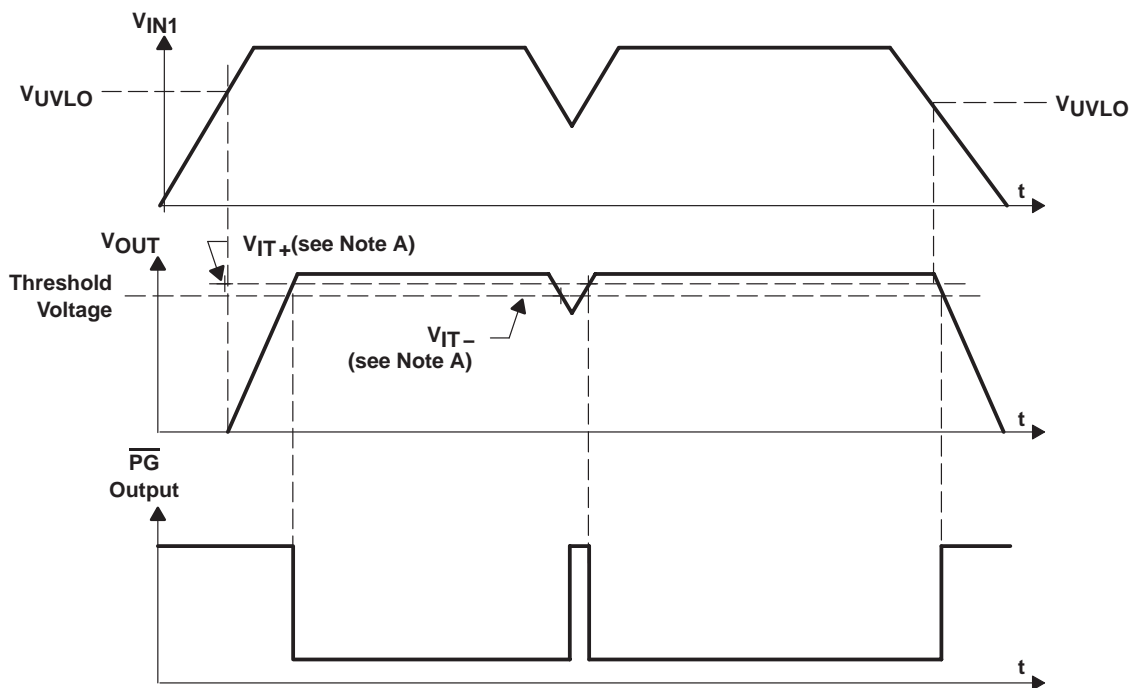

NOTE A: V_{IT-} – Trip voltage is typically 9% lower than the output voltage ($91\%V_O$). V_{IT-} to V_{IT+} is the hysteresis voltage.

detailed description

The TPS755xx family includes four fixed-output voltage regulators (1.5 V, 1.8 V, 2.5 V, and 3.3 V), and an adjustable regulator, the TPS75501 (adjustable from 1.22 V to 5 V). The bandgap voltage is typically 1.22 V.

pin functions

enable ($\overline{\text{EN}}$)

The $\overline{\text{EN}}$ terminal is an input which enables or shuts down the device. If $\overline{\text{EN}}$ is a logic high, the device will be in shutdown mode. When $\overline{\text{EN}}$ goes to logic low, the device will be enabled.

power-good ($\overline{\text{PG}}$)

The $\overline{\text{PG}}$ terminal for the fixed voltage option devices is an open drain, active low output that indicates the status of V_O (output of the LDO). When V_O reaches approximately 91% of the regulated voltage, $\overline{\text{PG}}$ will go to a low impedance state. It will go to a high-impedance state when V_O falls below approximately 89% (i.e. over load condition) of the regulated voltage. The open drain output of the $\overline{\text{PG}}$ terminal requires a pullup resistor.

feedback (FB)

FB is an input terminal used for the adjustable-output option and must be connected to the output terminal either directly, in order to generate the minimum output voltage of 1.22 V, or through an external feedback resistor divider for other output voltages. The FB connection should be as short as possible. It is essential to route it in such a way to minimize/avoid noise pickup. Adding RC networks between FB terminal and V_O to filter noise is not recommended because it may cause the regulator to oscillate.

TPS75515, TPS75518, TPS75525, TPS75533 WITH POWER GOOD AND TPS75501 FAST-TRANSIENT RESPONSE 5-A LOW-DROPOUT VOLTAGE REGULATORS

SLVS293D – NOVEMBER 2000 – REVISED MAY 2002

detailed description (continued)

input voltage (IN)

The V_{IN} terminal is an input to the regulator.

output voltage (OUTPUT)

The V_{OUTPUT} terminal is an output to the regulator.

absolute maximum ratings over operating junction temperature range (unless otherwise noted)†

Input voltage range‡, V_I	–0.3 V to 6 V
Voltage range at EN	–0.3 V to 6 V
Maximum PG voltage (fixed options only)	6 V
Peak output current	Internally limited
Continuous total power dissipation	See Dissipation Rating Tables
Output voltage, V_O (OUTPUT, FB)	5.5 V
Operating junction temperature range, T_J	–40°C to 150°C
Storage temperature range, T_{stg}	–65°C to 150°C
ESD rating, HBM	2 kV
ESD rating, CDM	500 V

† Stresses beyond those listed under “absolute maximum ratings” may cause permanent damage to the device. These are stress ratings only, and functional operation of the device at these or any other conditions beyond those indicated under “recommended operating conditions” is not implied. Exposure to absolute-maximum-rated conditions for extended periods may affect device reliability.

‡ All voltage values are with respect to network terminal ground.

DISSIPATION RATING TABLE

PACKAGE	$R_{\theta JC}$ (°C/W)	$R_{\theta JA}$ (°C/W)§
TO–220	2	58.7¶
TO–263	2	38.7#

§ For both packages, the $R_{\theta JA}$ values were computed using JEDEC high K board (2S2P) with 1 ounce internal copper plane and ground plane. There was no air flow across the packages.

¶ $R_{\theta JA}$ was computed assuming a vertical, free standing TO-220 package with pins soldered to the board. There is no heatsink attached to the package.

$R_{\theta JA}$ was computed assuming a horizontally mounted TO-263 package with pins soldered to the board. There is no copper pad underneath the package.

recommended operating conditions

	MIN	MAX	UNIT
Input voltage, $V_{I }$	2.8	5.5	V
Output voltage range, V_O	1.22	5	V
Output current, I_O	0	5	A
Operating virtual junction temperature, T_J	–40	125	°C

|| To calculate the minimum input voltage for your maximum output current, use the following equation: $V_{I(min)} = V_{O(max)} + V_{DO(max\ load)}$.

TPS75515, TPS75518, TPS75525, TPS75533 WITH POWER GOOD AND TPS75501 FAST-TRANSIENT RESPONSE 5-A LOW-DROPOUT VOLTAGE REGULATORS

SLVS293D – NOVEMBER 2000 – REVISED MAY 2002

electrical characteristics over recommended operating junction temperature range ($T_J = -40^\circ\text{C}$ to 125°C), $V_I = V_O(\text{typ}) + 1\text{ V}$, $I_O = 1\text{ mA}$, $\overline{\text{EN}} = 0\text{ V}$, $C_O = 100\ \mu\text{F}$ (unless otherwise noted)

PARAMETER		TEST CONDITIONS	MIN	TYP	MAX	UNIT
Output voltage (see Note 2)	Adjustable voltage	$1.22\text{ V} \leq V_O \leq 5.5\text{ V}$, $T_J = 25^\circ\text{C}$	V_O			V
		$1.22\text{ V} \leq V_O \leq 5.5\text{ V}$	$0.97 V_O$	$1.03 V_O$		
		$1.22\text{ V} \leq V_O \leq 5.5\text{ V}$, $T_J = 0$ to 125°C (see Note 1)	$0.98 V_O$	$1.02 V_O$		
	1.5 V Output	$T_J = 25^\circ\text{C}$, $2.8\text{ V} < V_I < 5.5\text{ V}$	1.5			V
		$2.8\text{ V} \leq V_I \leq 5.5\text{ V}$	1.455	1.545		
	1.8 V Output	$T_J = 25^\circ\text{C}$, $2.8\text{ V} < V_I < 5.5\text{ V}$	1.8			V
		$2.8\text{ V} \leq V_I \leq 5.5\text{ V}$	1.746	1.854		
	2.5 V Output	$T_J = 25^\circ\text{C}$, $3.5\text{ V} < V_I < 5.5\text{ V}$	2.5			V
		$3.5\text{ V} \leq V_I \leq 5.5\text{ V}$	2.425	2.575		
	3.3 V Output	$T_J = 25^\circ\text{C}$, $4.3\text{ V} < V_I < 5.5\text{ V}$	3.3			V
		$4.3\text{ V} \leq V_I \leq 5.5\text{ V}$	3.201	3.399		
	Quiescent current (GND current) (see Notes 2 and 3)		$T_J = 25^\circ\text{C}$	125		
					200	
Output voltage line regulation ($\Delta V_O/V_O$) (see Note 3)		$V_O + 1\text{ V} \leq V_I \leq 5.5\text{ V}$, $T_J = 25^\circ\text{C}$	0.04			%V
		$V_O + 1\text{ V} \leq V_I < 5.5\text{ V}$			0.1	
Load regulation (see Note 2)			0.35			%V
Output noise voltage	TPS75515	$\text{BW} = 300\text{ Hz to } 50\text{ kHz}$, $T_J = 25^\circ\text{C}$, $V_I = 2.8\text{ V}$	35			μVrms
Output current limit		$V_O = 0\text{ V}$	5.5	10	14	A
Thermal shutdown junction temperature			150			$^\circ\text{C}$
Standby current		$\overline{\text{EN}} = V_I$, $T_J = 25^\circ\text{C}$	0.1			μA
		$\overline{\text{EN}} = V_I$			10	μA
FB input current	TPS75501	$\text{FB} = 1.5\text{ V}$	-1		1	μA
Power supply ripple rejection	TPS75515	$f = 100\text{ Hz}$, $T_J = 25^\circ\text{C}$, $V_I = 2.8\text{ V}$, $I_O = 5\text{ A}$	60			dB
Minimum input voltage for valid $\overline{\text{PG}}$		$I_O(\text{PG}) = 300\ \mu\text{A}$, $V(\text{PG}) \leq 0.8\text{ V}$	0			V
$\overline{\text{PG}}$ trip threshold voltage	Fixed options only	V_O decreasing	89		93	$\%V_O$
$\overline{\text{PG}}$ hysteresis voltage	Fixed options only	Measured at V_O	0.5			$\%V_O$
$\overline{\text{PG}}$ output low voltage	Fixed options only	$V_I = 2.8\text{ V}$, $I_O(\text{PG}) = 1\text{ mA}$	0.15		0.4	V
$\overline{\text{PG}}$ leakage current	Fixed options only	$V(\text{PG}) = 5\text{ V}$			1	μA

- NOTES: 1. The adjustable option operates with a 2% tolerance over $T_J = 0$ to 125°C .
2. $I_O = 1\text{ mA}$ to 5 A
3. If $V_O \leq 2.5\text{ V}$ then $V_{I\text{min}} = 2.8\text{ V}$, $V_{I\text{max}} = 5.5\text{ V}$:

$$\text{Line regulation (mV)} = (\%/V) \times \frac{V_O(V_{I\text{max}} - 2.8\text{ V})}{100} \times 1000$$

If $V_O > 2.5\text{ V}$ then $V_{I\text{min}} = V_O + 1\text{ V}$, $V_{I\text{max}} = 5.5\text{ V}$:

$$\text{Line regulation (mV)} = (\%/V) \times \frac{V_O(V_{I\text{max}} - (V_O + 1\text{ V}))}{100} \times 1000$$

TPS75515, TPS75518, TPS75525, TPS75533 WITH POWER GOOD AND TPS75501 FAST-TRANSIENT RESPONSE 5-A LOW-DROPOUT VOLTAGE REGULATORS

SLVS293D – NOVEMBER 2000 – REVISED MAY 2002

electrical characteristics over recommended operating junction temperature range ($T_J = -40^\circ\text{C}$ to 125°C), $V_I = V_O(\text{typ}) + 1\text{ V}$, $I_O = 1\text{ mA}$, $\overline{\text{EN}} = 0\text{ V}$, $C_O = 100\ \mu\text{F}$ (unless otherwise noted) (continued)

PARAMETER		TEST CONDITIONS	MIN	TYP	MAX	UNIT
Input current ($\overline{\text{EN}}$)		$\overline{\text{EN}} = V_I$	-1		1	μA
		$\overline{\text{EN}} = 0\text{ V}$	-1	0	1	μA
High level $\overline{\text{EN}}$ input voltage			2			V
Low level $\overline{\text{EN}}$ input voltage					0.7	V
V_O	Dropout voltage, (3.3 V output) (see Note 4)	$I_O = 5\text{ A}$, $V_I = 3.2\text{ V}$, $T_J = 25^\circ\text{C}$		250		mV
		$I_O = 5\text{ A}$, $V_I = 3.2\text{ V}$			500	
	Discharge transistor current	$V_O = 1.5\text{ V}$, $T_J = 25^\circ\text{C}$	10	25		mA
V_I	UVLO	$T_J = 25^\circ\text{C}$, V_I rising	2.2		2.75	V
	UVLO hysteresis	$T_J = 25^\circ\text{C}$, V_I falling		100		mV

NOTE 4: $\overline{\text{IN}}$ voltage equals $V_O(\text{typ}) - 100\text{ mV}$; TPS75515, TPS75518, and TPS75525 dropout voltage limited by input voltage range limitations (i.e., TPS75533 input voltage is set to 3.2 V for the purpose of this test).

TYPICAL CHARACTERISTICS

Table of Graphs

			FIGURE
V_O	Output voltage	vs Output current	2, 3
		vs Junction temperature	4, 5
	Ground current	vs Junction temperature	6
	Power supply ripple rejection	vs Frequency	7
	Output spectral noise density	vs Frequency	8
z_o	Output impedance	vs Frequency	9
V_{DO}	Dropout voltage	vs Input voltage	10
		vs Junction temperature	11
V_I	Minimum required input voltage	vs Output voltage	12
	Line transient response		13, 15
	Load transient response		14, 16
V_O	Output voltage and enable voltage	vs Time (start-up)	17
	Equivalent series resistance	vs Output current	19, 20

**TPS75515, TPS75518, TPS75525, TPS75533 WITH POWER GOOD AND
TPS75501 FAST-TRANSIENT RESPONSE 5-A LOW-DROPOUT
VOLTAGE REGULATORS**

SLVS293D – NOVEMBER 2000 – REVISED MAY 2002

TYPICAL CHARACTERISTICS

**TPS75533
OUTPUT VOLTAGE
vs
OUTPUT CURRENT**

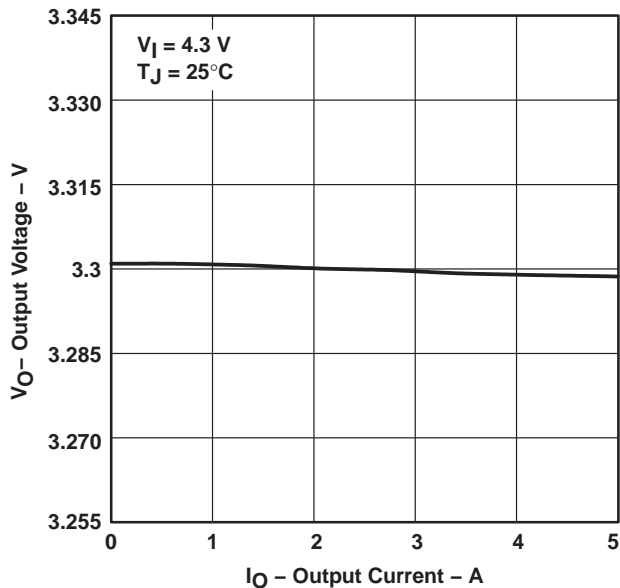

Figure 2

**TPS75515
OUTPUT VOLTAGE
vs
OUTPUT CURRENT**

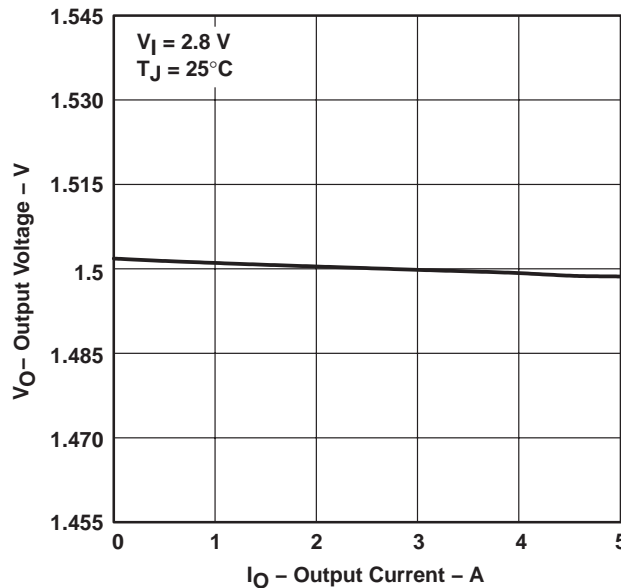

Figure 3

**TPS75533
OUTPUT VOLTAGE
vs
JUNCTION TEMPERATURE**

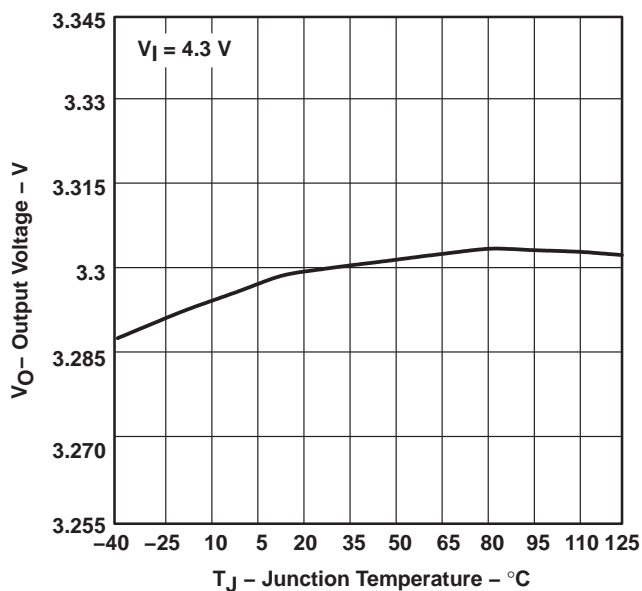

Figure 4

**TPS75515
OUTPUT VOLTAGE
vs
JUNCTION TEMPERATURE**

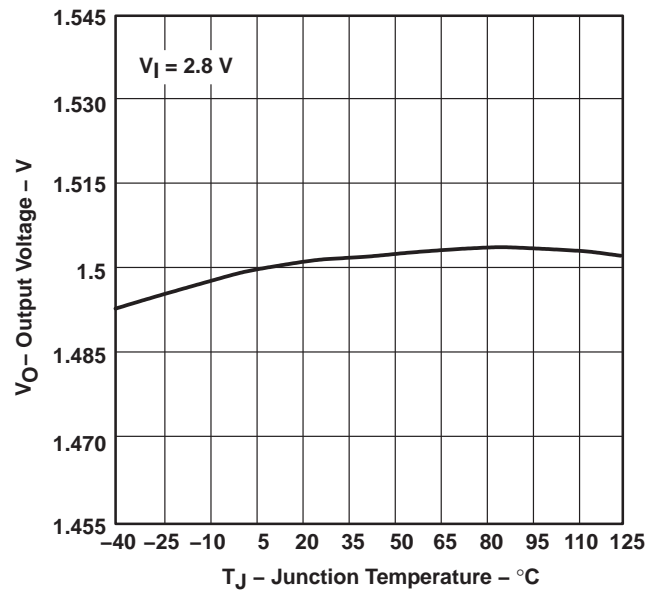
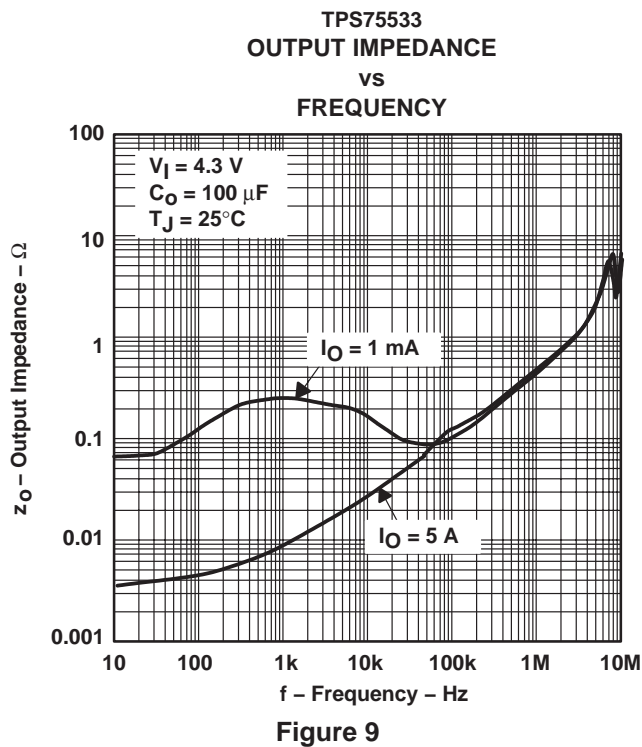
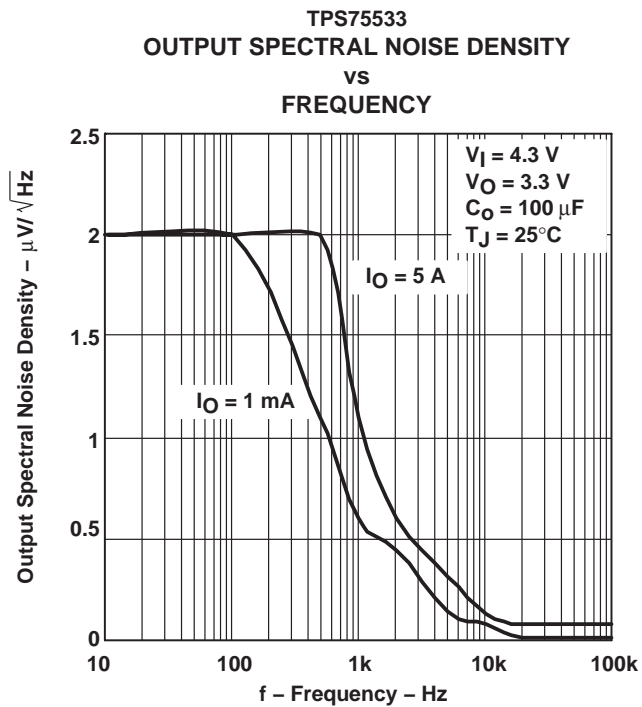
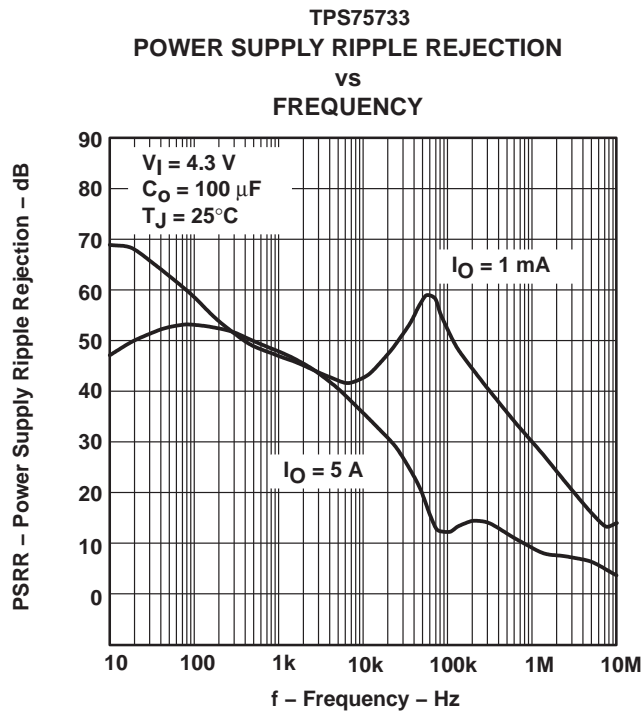
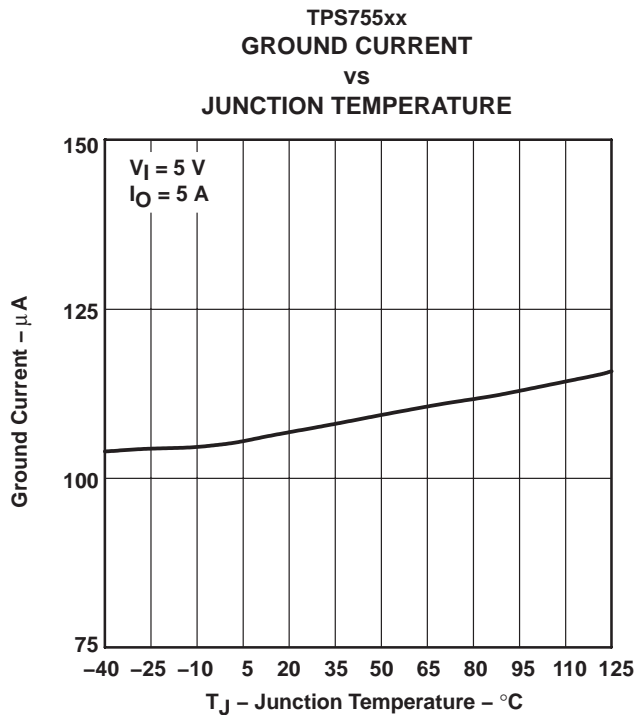

Figure 5

TPS75515, TPS75518, TPS75525, TPS75533 WITH POWER GOOD AND TPS75501 FAST-TRANSIENT RESPONSE 5-A LOW-DROPOUT VOLTAGE REGULATORS

SLVS293D – NOVEMBER 2000 – REVISED MAY 2002

TYPICAL CHARACTERISTICS



TPS75515, TPS75518, TPS75525, TPS75533 WITH POWER GOOD AND TPS75501 FAST-TRANSIENT RESPONSE 5-A LOW-DROPOUT VOLTAGE REGULATORS

SLVS293D – NOVEMBER 2000 – REVISED MAY 2002

TYPICAL CHARACTERISTICS

**TPS75501
DROPOUT VOLTAGE
vs
INPUT VOLTAGE**

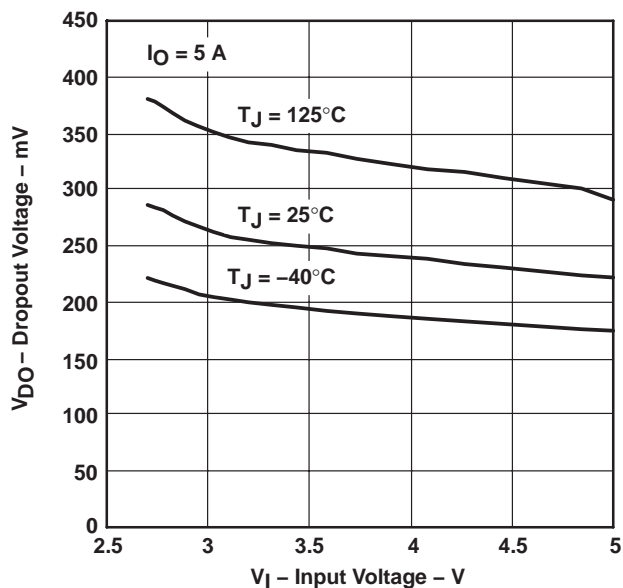

Figure 10

**TPS75533
DROPOUT VOLTAGE
vs
JUNCTION TEMPERATURE**

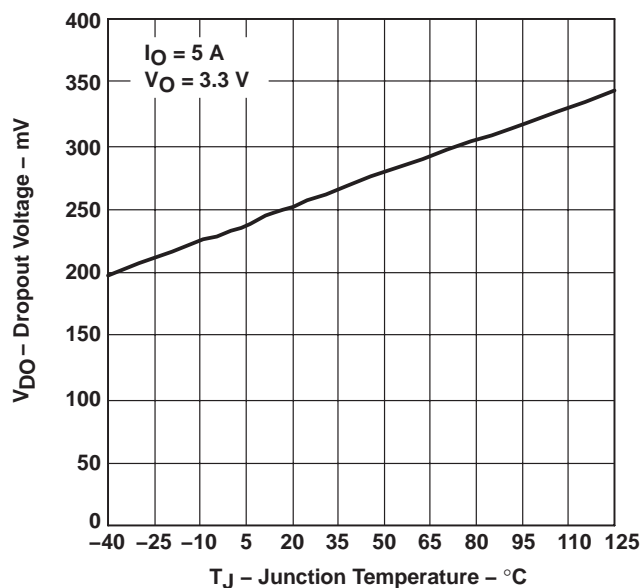

Figure 11

**MINIMUM REQUIRED INPUT VOLTAGE
vs
OUTPUT VOLTAGE**

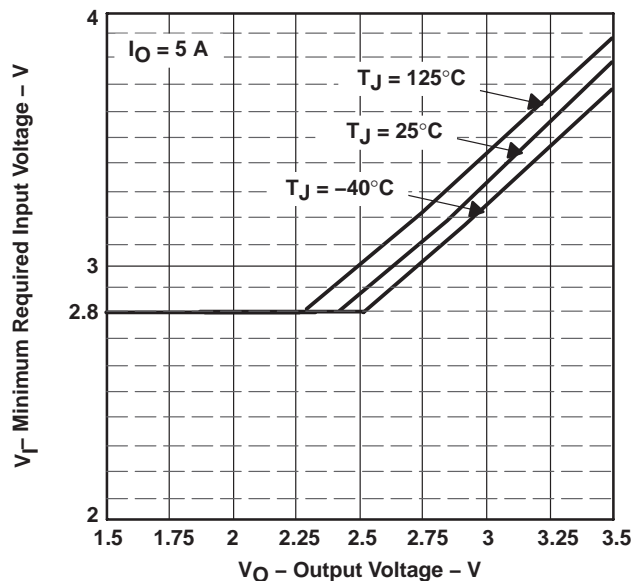

Figure 12

**TPS75515
LINE TRANSIENT RESPONSE**

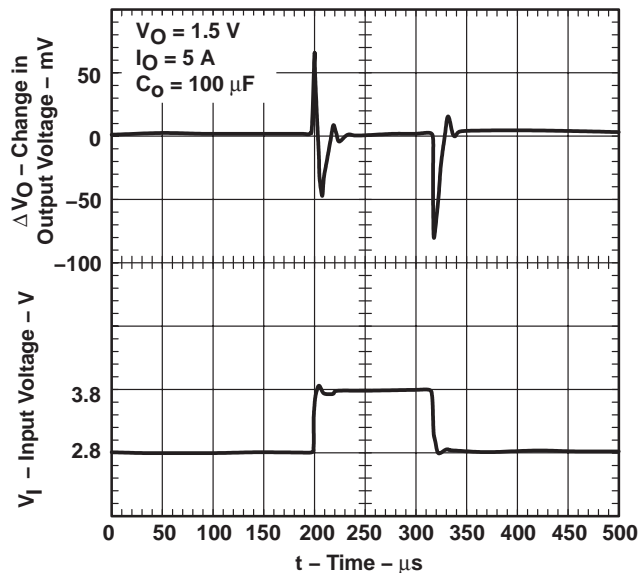

Figure 13

TPS75515, TPS75518, TPS75525, TPS75533 WITH POWER GOOD AND TPS75501 FAST-TRANSIENT RESPONSE 5-A LOW-DROPOUT VOLTAGE REGULATORS

SLVS293D – NOVEMBER 2000 – REVISED MAY 2002

TYPICAL CHARACTERISTICS

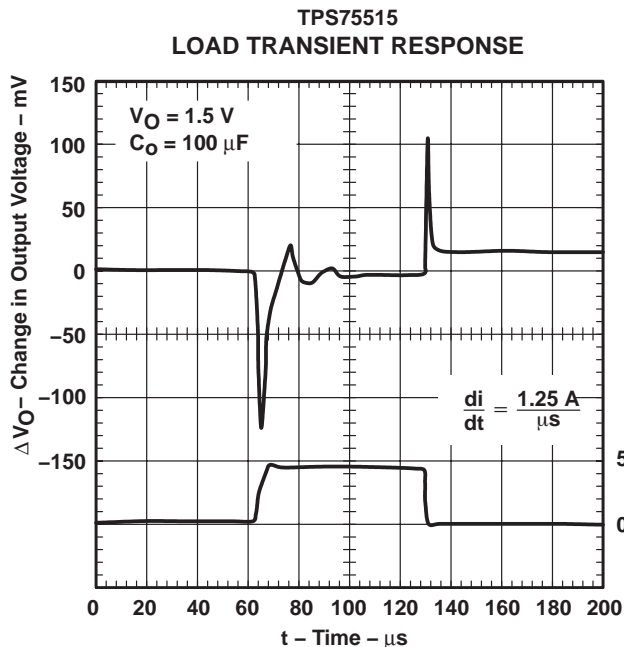

Figure 14

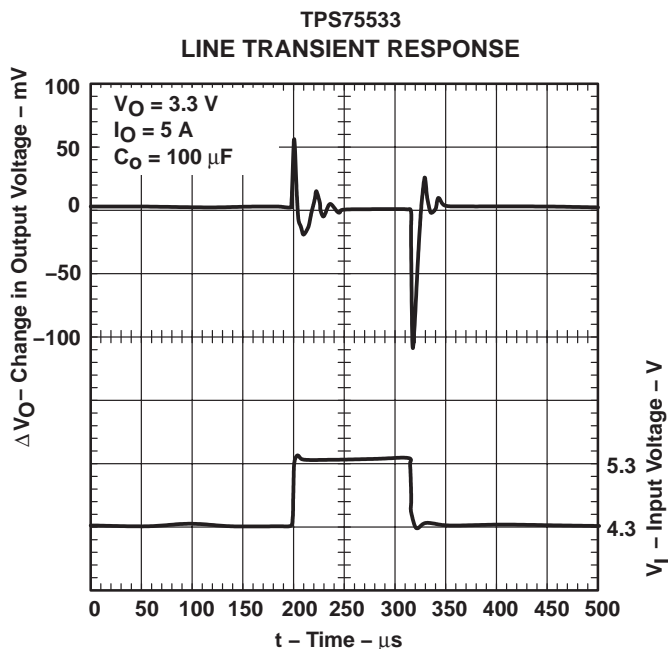

Figure 15

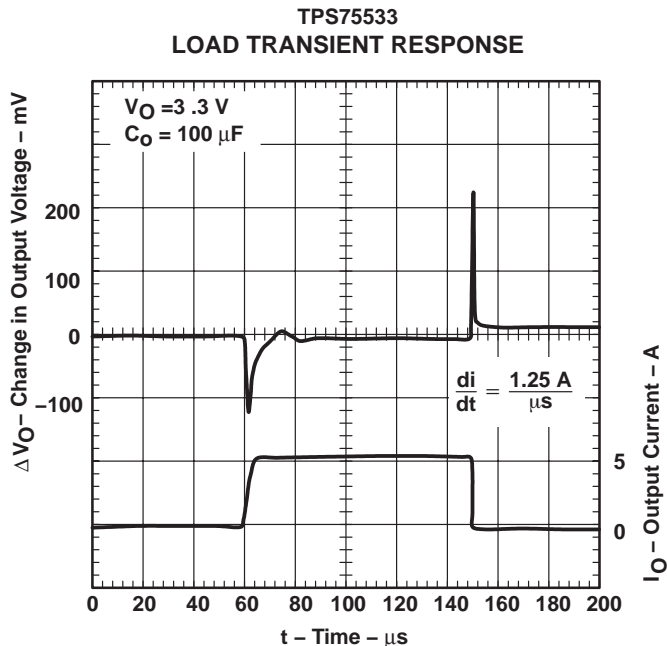

Figure 16

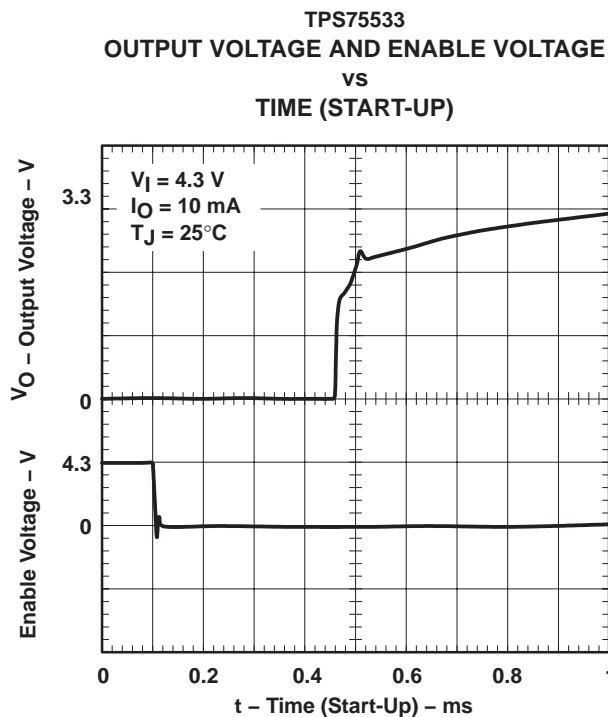

Figure 17

**TPS75515, TPS75518, TPS75525, TPS75533 WITH POWER GOOD AND
 TPS75501 FAST-TRANSIENT RESPONSE 5-A LOW-DROPOUT
 VOLTAGE REGULATORS**

SLVS293D – NOVEMBER 2000 – REVISED MAY 2002

TYPICAL CHARACTERISTICS

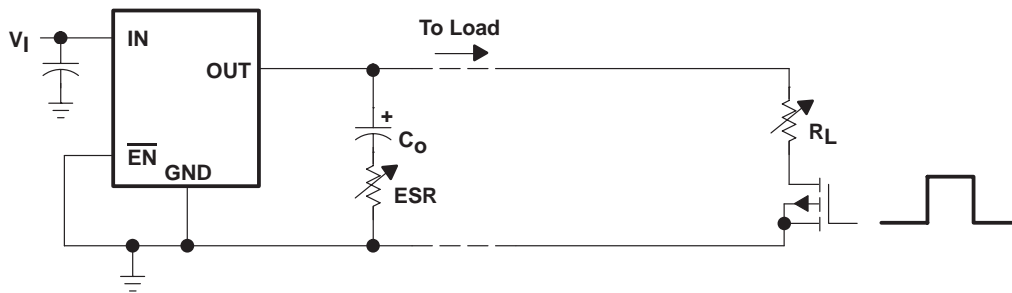

Figure 18. Test Circuit for Typical Regions of Stability (Figures 19 and 20) (Fixed Output Options)

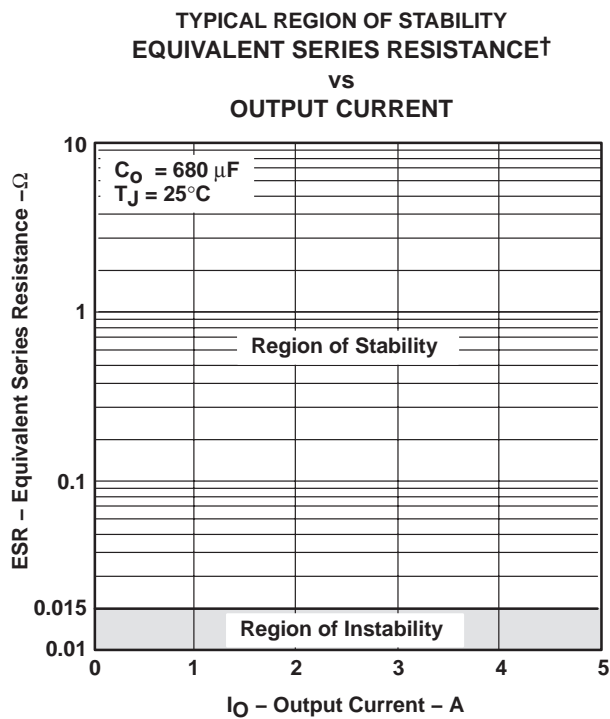

Figure 19

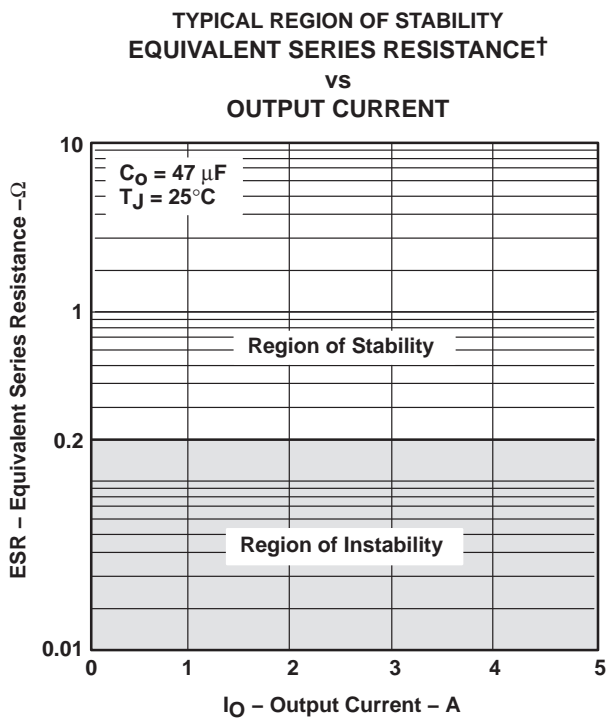

Figure 20

† Equivalent series resistance (ESR) refers to the total series resistance, including the ESR of the capacitor, any series resistance added externally, and PWB trace resistance to C_O .

THERMAL INFORMATION

The amount of heat that an LDO linear regulator generates is directly proportional to the amount of power it dissipates during operation. All integrated circuits have a maximum allowable junction temperature (T_{Jmax}) above which normal operation is not assured. A system designer must design the operating environment so that the operating junction temperature (T_J) does not exceed the maximum junction temperature (T_{Jmax}). The two main environmental variables that a designer can use to improve thermal performance are air flow and external heatsinks. The purpose of this information is to aid the designer in determining the proper operating environment for a linear regulator that is operating at a specific power level.

In general, the maximum expected power ($P_{D(max)}$) consumed by a linear regulator is computed as:

$$P_{Dmax} = (V_{I(avg)} - V_{O(avg)}) \times I_{O(avg)} + V_{I(avg)} \times I_{(Q)} \quad (1)$$

Where:

$V_{I(avg)}$ is the average input voltage.

$V_{O(avg)}$ is the average output voltage.

$I_{O(avg)}$ is the average output current.

$I_{(Q)}$ is the quiescent current.

For most TI LDO regulators, the quiescent current is insignificant compared to the average output current; therefore, the term $V_{I(avg)} \times I_{(Q)}$ can be neglected. The operating junction temperature is computed by adding the ambient temperature (T_A) and the increase in temperature due to the regulator's power dissipation. The temperature rise is computed by multiplying the maximum expected power dissipation by the sum of the thermal resistances between the junction and the case ($R_{\theta JC}$), the case to heatsink ($R_{\theta CS}$), and the heatsink to ambient ($R_{\theta SA}$). Thermal resistances are measures of how effectively an object dissipates heat. Typically, the larger the device, the more surface area available for power dissipation and the lower the object's thermal resistance.

Figure 21 illustrates these thermal resistances for (a) a TO-220 package attached to a heatsink, and (b) a TO-263 package mounted on a JEDEC High-K board.

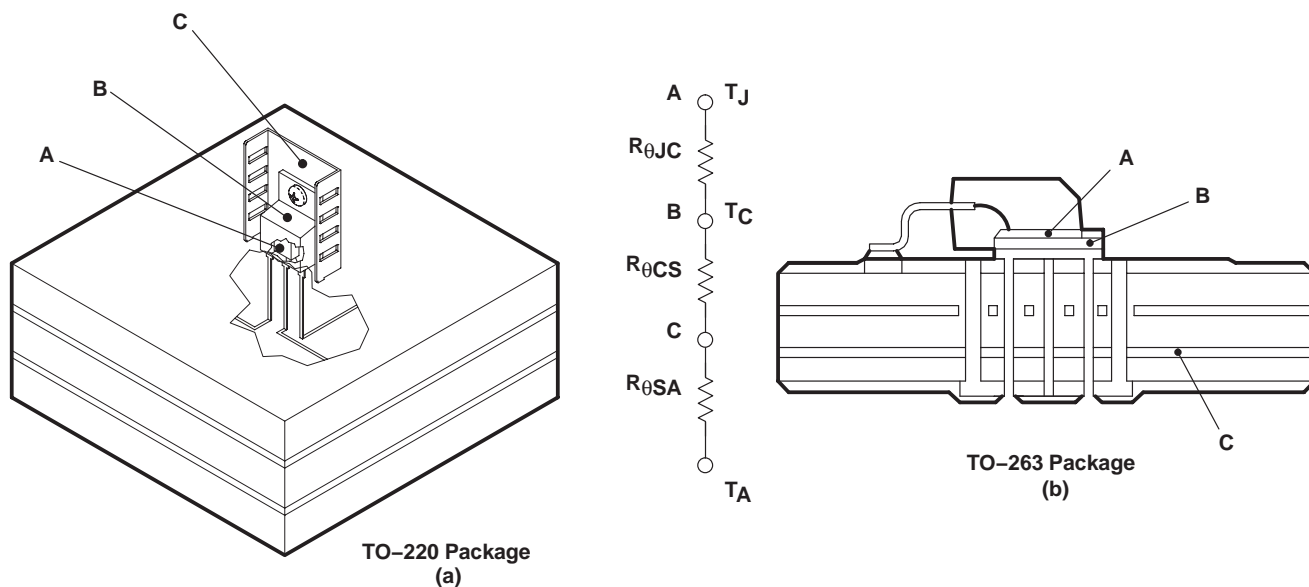

Figure 21. Thermal Resistances

TPS75515, TPS75518, TPS75525, TPS75533 WITH POWER GOOD AND TPS75501 FAST-TRANSIENT RESPONSE 5-A LOW-DROPOUT VOLTAGE REGULATORS

SLVS293D – NOVEMBER 2000 – REVISED MAY 2002

THERMAL INFORMATION

Equation 2 summarizes the computation:

$$T_J = T_A + P_{D\max} \times (R_{\theta JC} + R_{\theta CS} + R_{\theta SA}) \quad (2)$$

The $R_{\theta JC}$ is specific to each regulator as determined by its package, lead frame, and die size provided in the regulator's datasheet. The $R_{\theta SA}$ is a function of the type and size of heatsink. For example, *black body radiator* type heatsinks, like the one attached to the TO-220 package in Figure 21(a), can have $R_{\theta CS}$ values ranging from 5°C/W for very large heatsinks to 50°C/W for very small heatsinks. The $R_{\theta CS}$ is a function of how the package is attached to the heatsink. For example, if a thermal compound is used to attach a heatsink to a TO-220 package, $R_{\theta CS}$ of 1°C/W is reasonable.

Even if no external *black body radiator* type heatsink is attached to the package, the board on which the regulator is mounted will provide some heatsinking through the pin solder connections. Some packages, like the TO-263 and TI's TSSOP PowerPAD™ packages, use a copper plane underneath the package or the circuit board's ground plane for additional heatsinking to improve their thermal performance. Computer aided thermal modeling can be used to compute very accurate approximations of an integrated circuit's thermal performance in different operating environments (e.g., different types of circuit boards, different types and sizes of heatsinks, and different air flows, etc.). Using these models, the three thermal resistances can be combined into one thermal resistance between junction and ambient ($R_{\theta JA}$). This $R_{\theta JA}$ is valid only for the specific operating environment used in the computer model.

Equation 2 simplifies into equation 3:

$$T_J = T_A + P_{D\max} \times R_{\theta JA} \quad (3)$$

Rearranging equation 3 gives equation 4:

$$R_{\theta JA} = \frac{T_J - T_A}{P_{D\max}} \quad (4)$$

Using equation 3 and the computer model generated curves shown in Figures 22 and 25, a designer can quickly compute the required heatsink thermal resistance/board area for a given ambient temperature, power dissipation, and operating environment.

THERMAL INFORMATION

TO–220 power dissipation

The TO–220 package provides an effective means of managing power dissipation in through-hole applications. The TO–220 package dimensions are provided in the *Mechanical Data* section at the end of the data sheet. A heatsink can be used with the TO–220 package to effectively lower the junction-to-ambient thermal resistance.

To illustrate, the TPS75525 in a TO–220 package was chosen. For this example, the average input voltage is 3.3 V, the output voltage is 2.5 V, the average output current is 3 A, the ambient temperature 55°C, the air flow is 150 LFM, and the operating environment is the same as documented below. Neglecting the quiescent current, the maximum average power is:

$$P_{Dmax} = (3.3 - 2.5) V \times 3 A = 2.4 W \quad (5)$$

Substituting T_{Jmax} for T_J into equation 4 gives equation 6:

$$R_{\theta JAmax} = (125 - 55)^\circ C / 2.4 W = 29^\circ C/W \quad (6)$$

From Figure 22, $R_{\theta JA}$ vs Heatsink Thermal Resistance, a heatsink with $R_{\theta SA} = 22^\circ C/W$ is required to dissipate 2.4 W. The model operating environment used in the computer model to construct Figure 22 consisted of a standard JEDEC High-K board (2S2P) with a 1 oz. internal copper plane and ground plane. Since the package pins were soldered to the board, 450 mm² of the board was modeled as a heatsink. Figure 23 shows the side view of the operating environment used in the computer model.

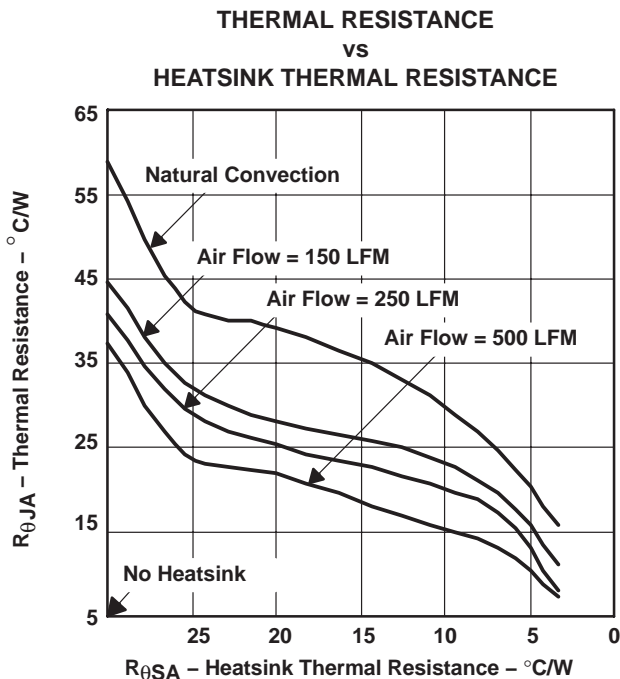

Figure 22

**TPS75515, TPS75518, TPS75525, TPS75533 WITH POWER GOOD AND
 TPS75501 FAST-TRANSIENT RESPONSE 5-A LOW-DROPOUT
 VOLTAGE REGULATORS**

SLVS293D – NOVEMBER 2000 – REVISED MAY 2002

THERMAL INFORMATION

TO-220 power dissipation (continued)

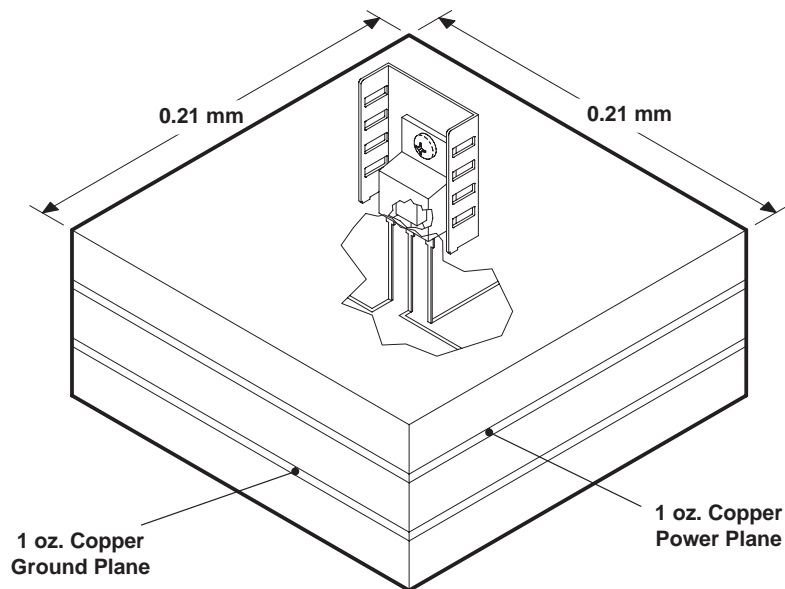

Figure 23

From the data in Figure 22 and rearranging equation 4, the maximum power dissipation for a different heatsink $R_{\theta SA}$ and a specific ambient temperature can be computed (see Figure 24).

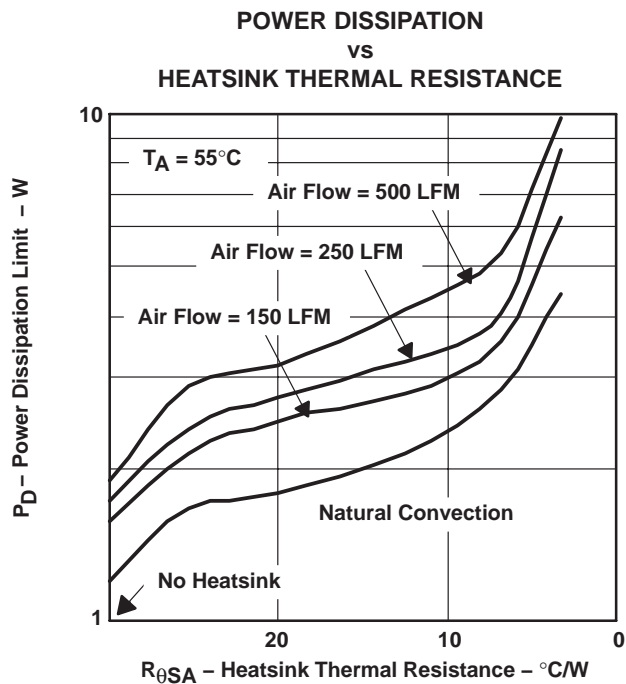

Figure 24

THERMAL INFORMATION

TO–263 power dissipation

The TO–263 package provides an effective means of managing power dissipation in surface mount applications. The TO–263 package dimensions are provided in the *Mechanical Data* section at the end of the data sheet. The addition of a copper plane directly underneath the TO–263 package enhances the thermal performance of the package.

To illustrate, the TPS75525 in a TO–263 package was chosen. For this example, the average input voltage is 3.3 V, the output voltage is 2.5 V, the average output current is 3 A, the ambient temperature 55°C, the air flow is 150 LFM, and the operating environment is the same as documented below. Neglecting the quiescent current, the maximum average power is:

$$P_{Dmax} = (3.3 - 2.5) V \times 3 A = 2.4 W \tag{7}$$

Substituting T_{Jmax} for T_J into equation 4 gives equation 8:

$$R_{\theta JAmax} = (125 - 55)^\circ C / 2.4 W = 29^\circ C/W \tag{8}$$

From Figure 25, $R_{\theta JA}$ vs Copper Heatsink Area, the ground plane needs to be 2 cm² for the part to dissipate 2.4 W. The model operating environment used in the computer model to construct Figure 25 consisted of a standard JEDEC High-K board (2S2P) with a 1 oz. internal copper plane and ground plane. The package is soldered to a 2 oz. copper pad. The pad is tied through thermal vias to the 1 oz. ground plane. Figure 26 shows the side view of the operating environment used in the computer model.

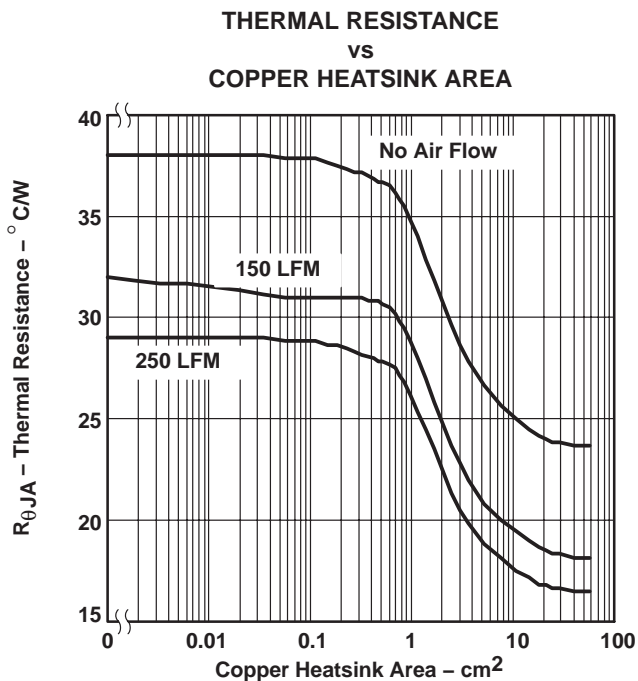

Figure 25

**TPS75515, TPS75518, TPS75525, TPS75533 WITH POWER GOOD AND
TPS75501 FAST-TRANSIENT RESPONSE 5-A LOW-DROPOUT
VOLTAGE REGULATORS**

SLVS293D – NOVEMBER 2000 – REVISED MAY 2002

THERMAL INFORMATION

TO–263 power dissipation (continued)

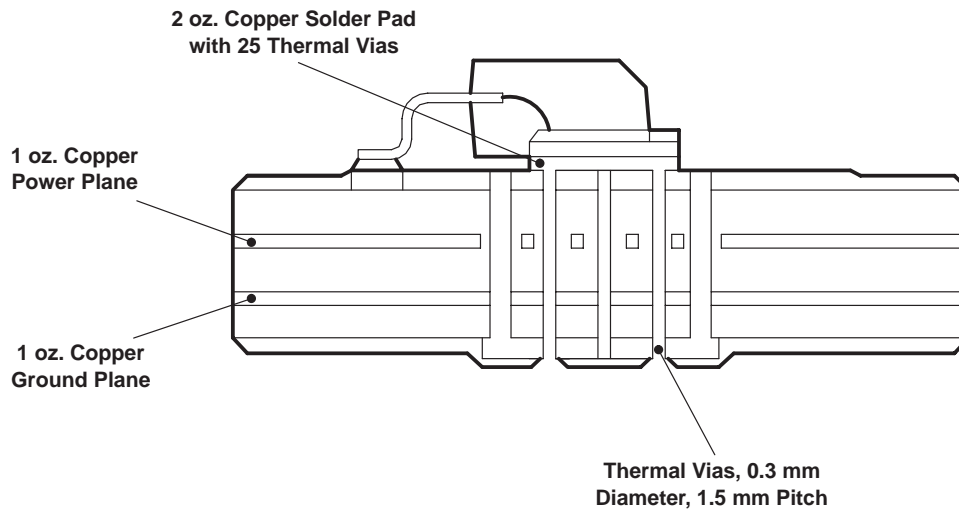

Figure 26

From the data in Figure 25 and rearranging equation 4, the maximum power dissipation for a different ground plane area and a specific ambient temperature can be computed (see Figure 27).

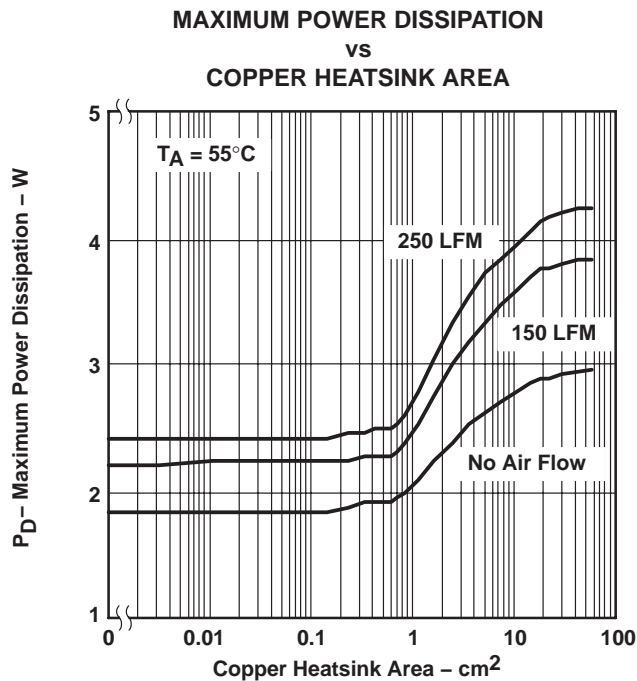

Figure 27

APPLICATION INFORMATION

programming the TPS75501 adjustable LDO regulator

The output voltage of the TPS75501 adjustable regulator is programmed using an external resistor divider as shown in Figure 28. The output voltage is calculated using:

$$V_O = V_{ref} \times \left(1 + \frac{R1}{R2}\right) \quad (9)$$

Where:

$$V_{ref} = 1.224 \text{ V typ (the internal reference voltage)}$$

Resistors R1 and R2 should be chosen for approximately 40- μ A divider current. Lower value resistors can be used but offer no inherent advantage and waste more power. Higher values should be avoided as leakage currents at FB increase the output voltage error. The recommended design procedure is to choose R2 = 30.1 k Ω to set the divider current at 40 μ A and then calculate R1 using:

$$R1 = \left(\frac{V_O}{V_{ref}} - 1\right) \times R2 \quad (10)$$

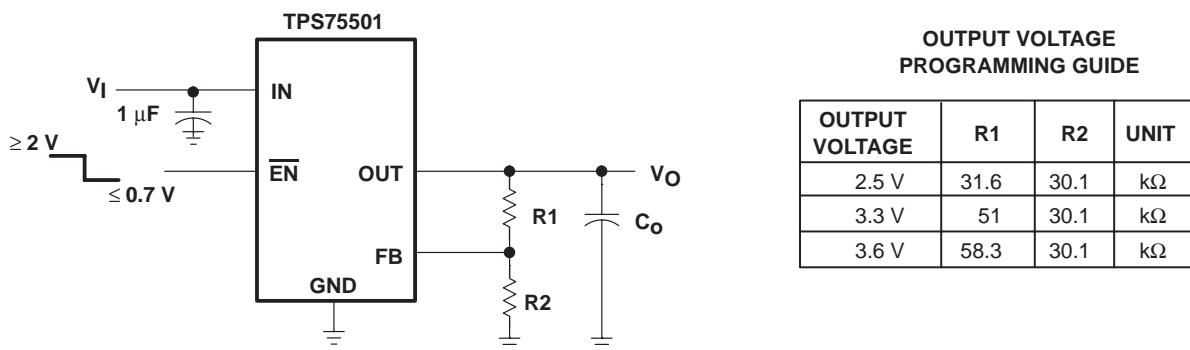

Figure 28. TPS75501 Adjustable LDO Regulator Programming

regulator protection

The TPS755xx PMOS-pass transistor has a built-in back diode that conducts reverse currents when the input voltage drops below the output voltage (e.g., during power down). Current is conducted from the output to the input and is not internally limited. When extended reverse voltage is anticipated, external limiting may be appropriate.

The TPS755xx also features internal current limiting and thermal protection. During normal operation, the TPS755xx limits output current to approximately 10 A. When current limiting engages, the output voltage scales back linearly until the overcurrent condition ends. While current limiting is designed to prevent gross device failure, care should be taken not to exceed the power dissipation ratings of the package. If the temperature of the device exceeds 150°C(typ), thermal-protection circuitry shuts it down. Once the device has cooled below 130°C(typ), regulator operation resumes.

TPS75515, TPS75518, TPS75525, TPS75533 WITH POWER GOOD AND TPS75501 FAST-TRANSIENT RESPONSE 5-A LOW-DROPOUT VOLTAGE REGULATORS

SLVS293D – NOVEMBER 2000 – REVISED MAY 2002

APPLICATION INFORMATION

input capacitor

For a typical application, a ceramic input bypass capacitor (0.22 μF –1 μF) is recommended to ensure device stability. This capacitor should be as close as possible to the input pin. Due to the impedance of the input supply, large transient currents will cause the input voltage to droop. If this droop causes the input voltage to drop below the UVLO threshold, the device will turn off. Therefore, it is recommended that a larger capacitor be placed in parallel with the ceramic bypass capacitor at the regulator's input. The size of this capacitor depends on the output current, response time of the main power supply, and the main power supply's distance to the regulator. At a minimum, the capacitor should be sized to ensure that the input voltage does not drop below the minimum UVLO threshold voltage during normal operating conditions.

output capacitor

As with most LDO regulators, the TPS755xx requires an output capacitor connected between OUT and GND to stabilize the internal control loop. The minimum recommended capacitance value is 47 μF with an ESR (equivalent series resistance) of at least 200 m Ω . As shown in Figure 29, most capacitor and ESR combinations with a product of $47\text{e-}6 \times 0.2 = 9.4\text{e-}6$ or larger will be stable, provided the capacitor value is at least 47 μF . Solid tantalum electrolytic and aluminum electrolytic capacitors are all suitable, provided they meet the requirements described in this section. Larger capacitors provide a wider range of stability and better load transient response.

This information along with the ESR graphs, Figures 19, 20, and 29, is included to assist in selection of suitable capacitance for the user's application. When necessary to achieve low height requirements along with high output current and/or high load capacitance, several higher ESR capacitors can be used in parallel to meet these guidelines.

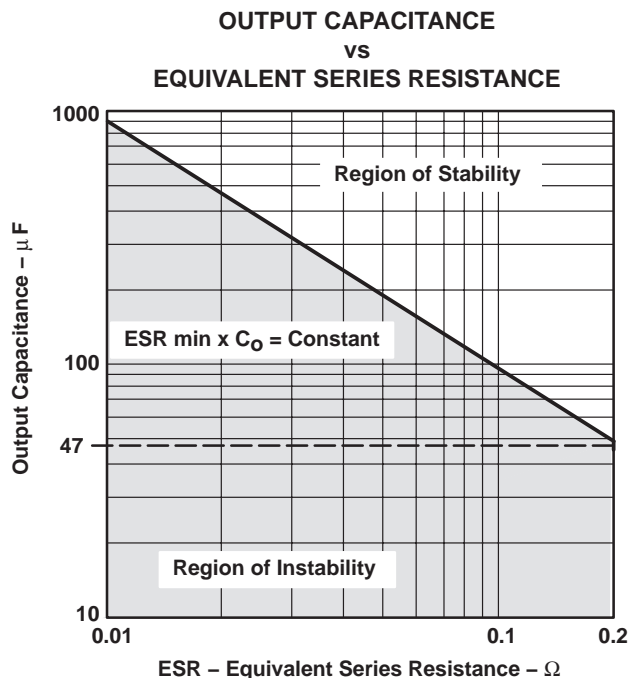

Figure 29

PACKAGE OPTION ADDENDUM

10-Jun-2014

PACKAGING INFORMATION

Orderable Device	Status (1)	Package Type	Package Drawing	Pins	Package Qty	Eco Plan (2)	Lead/Ball Finish (6)	MSL Peak Temp (3)	Op Temp (°C)	Device Marking (4/5)	Samples
TPS75501KC	ACTIVE	TO-220	KC	5	50	Green (RoHS & no Sb/Br)	CU SN	N / A for Pkg Type	-40 to 125	75501	Samples
TPS75501KTT	OBSOLETE	DDPAK/ TO-263	KTT	5		TBD	Call TI	Call TI	-40 to 125		
TPS75501KTTR	ACTIVE	DDPAK/ TO-263	KTT	5	500	Green (RoHS & no Sb/Br)	CU SN	Level-2-260C-1 YEAR	-40 to 125	75501	Samples
TPS75501KTTRG3	ACTIVE	DDPAK/ TO-263	KTT	5	500	Green (RoHS & no Sb/Br)	CU SN	Level-2-260C-1 YEAR	-40 to 125	75501	Samples
TPS75501KTTT	ACTIVE	DDPAK/ TO-263	KTT	5	50	Green (RoHS & no Sb/Br)	CU SN	Level-2-260C-1 YEAR		75501	Samples
TPS75501KTTTG3	ACTIVE	DDPAK/ TO-263	KTT	5	50	Green (RoHS & no Sb/Br)	CU SN	Level-2-260C-1 YEAR		75501	Samples
TPS75515KC	ACTIVE	TO-220	KC	5	50	Green (RoHS & no Sb/Br)	CU SN	N / A for Pkg Type	-40 to 125	75515	Samples
TPS75515KCG3	ACTIVE	TO-220	KC	5	50	Green (RoHS & no Sb/Br)	CU SN	N / A for Pkg Type	-40 to 125	75515	Samples
TPS75515KTT	OBSOLETE	DDPAK/ TO-263	KTT	5		TBD	Call TI	Call TI	-40 to 125		
TPS75515KTTR	ACTIVE	DDPAK/ TO-263	KTT	5	500	Green (RoHS & no Sb/Br)	CU SN	Level-2-260C-1 YEAR	-40 to 125	75515	Samples
TPS75515KTTT	ACTIVE	DDPAK/ TO-263	KTT	5	50	Green (RoHS & no Sb/Br)	CU SN	Level-2-260C-1 YEAR		75515	Samples
TPS75515KTTTG3	ACTIVE	DDPAK/ TO-263	KTT	5	50	Green (RoHS & no Sb/Br)	CU SN	Level-2-260C-1 YEAR		75515	Samples
TPS75518KC	ACTIVE	TO-220	KC	5	50	Green (RoHS & no Sb/Br)	CU SN	N / A for Pkg Type	-40 to 125	75518	Samples
TPS75518KCG3	ACTIVE	TO-220	KC	5	50	Green (RoHS & no Sb/Br)	CU SN	N / A for Pkg Type	-40 to 125	75518	Samples
TPS75518KTT	OBSOLETE	DDPAK/ TO-263	KTT	5		TBD	Call TI	Call TI	-40 to 125		
TPS75518KTTR	ACTIVE	DDPAK/ TO-263	KTT	5	500	Green (RoHS & no Sb/Br)	CU SN	Level-2-260C-1 YEAR	-40 to 125	75518	Samples
TPS75518KTTRG3	ACTIVE	DDPAK/ TO-263	KTT	5	500	Green (RoHS & no Sb/Br)	CU SN	Level-2-260C-1 YEAR	-40 to 125	75518	Samples

PACKAGE OPTION ADDENDUM

10-Jun-2014

Orderable Device	Status (1)	Package Type	Package Drawing	Pins	Package Qty	Eco Plan (2)	Lead/Ball Finish (6)	MSL Peak Temp (3)	Op Temp (°C)	Device Marking (4/5)	Samples
TPS75518KTTT	ACTIVE	DDPAK/ TO-263	KTT	5	50	Green (RoHS & no Sb/Br)	CU SN	Level-2-260C-1 YEAR		75518	Samples
TPS75518KTTTG3	ACTIVE	DDPAK/ TO-263	KTT	5	50	Green (RoHS & no Sb/Br)	CU SN	Level-2-260C-1 YEAR		75518	Samples
TPS75525KC	ACTIVE	TO-220	KC	5	50	Green (RoHS & no Sb/Br)	CU SN	N / A for Pkg Type	-40 to 125	75525	Samples
TPS75525KTT	OBSOLETE	DDPAK/ TO-263	KTT	5		TBD	Call TI	Call TI	-40 to 125		
TPS75525KTTR	ACTIVE	DDPAK/ TO-263	KTT	5	500	Green (RoHS & no Sb/Br)	CU SN	Level-2-260C-1 YEAR	-40 to 125	75525	Samples
TPS75525KTTT	ACTIVE	DDPAK/ TO-263	KTT	5	50	Green (RoHS & no Sb/Br)	CU SN	Level-2-260C-1 YEAR		75525	Samples
TPS75525KTTTG3	ACTIVE	DDPAK/ TO-263	KTT	5	50	Green (RoHS & no Sb/Br)	CU SN	Level-2-260C-1 YEAR		75525	Samples
TPS75533KC	ACTIVE	TO-220	KC	5	50	Green (RoHS & no Sb/Br)	CU SN	N / A for Pkg Type	-40 to 125	75533	Samples
TPS75533KCG3	ACTIVE	TO-220	KC	5	50	Green (RoHS & no Sb/Br)	CU SN	N / A for Pkg Type	-40 to 125	75533	Samples
TPS75533KTT	OBSOLETE	DDPAK/ TO-263	KTT	5		TBD	Call TI	Call TI	-40 to 125		
TPS75533KTTR	ACTIVE	DDPAK/ TO-263	KTT	5	500	Green (RoHS & no Sb/Br)	CU SN	Level-2-260C-1 YEAR	-40 to 125	75533	Samples
TPS75533KTTRG3	ACTIVE	DDPAK/ TO-263	KTT	5	500	Green (RoHS & no Sb/Br)	CU SN	Level-2-260C-1 YEAR	-40 to 125	75533	Samples
TPS75533KTTT	ACTIVE	DDPAK/ TO-263	KTT	5	50	Green (RoHS & no Sb/Br)	CU SN	Level-2-260C-1 YEAR		75533	Samples
TPS75533KTTTG3	ACTIVE	DDPAK/ TO-263	KTT	5	50	Green (RoHS & no Sb/Br)	CU SN	Level-2-260C-1 YEAR		75533	Samples

(1) The marketing status values are defined as follows:

ACTIVE: Product device recommended for new designs.

LIFEBUY: TI has announced that the device will be discontinued, and a lifetime-buy period is in effect.

NRND: Not recommended for new designs. Device is in production to support existing customers, but TI does not recommend using this part in a new design.

PREVIEW: Device has been announced but is not in production. Samples may or may not be available.

OBSOLETE: TI has discontinued the production of the device.

⁽²⁾ Eco Plan - The planned eco-friendly classification: Pb-Free (RoHS), Pb-Free (RoHS Exempt), or Green (RoHS & no Sb/Br) - please check <http://www.ti.com/productcontent> for the latest availability information and additional product content details.

TBD: The Pb-Free/Green conversion plan has not been defined.

Pb-Free (RoHS): TI's terms "Lead-Free" or "Pb-Free" mean semiconductor products that are compatible with the current RoHS requirements for all 6 substances, including the requirement that lead not exceed 0.1% by weight in homogeneous materials. Where designed to be soldered at high temperatures, TI Pb-Free products are suitable for use in specified lead-free processes.

Pb-Free (RoHS Exempt): This component has a RoHS exemption for either 1) lead-based flip-chip solder bumps used between the die and package, or 2) lead-based die adhesive used between the die and leadframe. The component is otherwise considered Pb-Free (RoHS compatible) as defined above.

Green (RoHS & no Sb/Br): TI defines "Green" to mean Pb-Free (RoHS compatible), and free of Bromine (Br) and Antimony (Sb) based flame retardants (Br or Sb do not exceed 0.1% by weight in homogeneous material)

⁽³⁾ MSL, Peak Temp. - The Moisture Sensitivity Level rating according to the JEDEC industry standard classifications, and peak solder temperature.

⁽⁴⁾ There may be additional marking, which relates to the logo, the lot trace code information, or the environmental category on the device.

⁽⁵⁾ Multiple Device Markings will be inside parentheses. Only one Device Marking contained in parentheses and separated by a "~" will appear on a device. If a line is indented then it is a continuation of the previous line and the two combined represent the entire Device Marking for that device.

⁽⁶⁾ Lead/Ball Finish - Orderable Devices may have multiple material finish options. Finish options are separated by a vertical ruled line. Lead/Ball Finish values may wrap to two lines if the finish value exceeds the maximum column width.

Important Information and Disclaimer: The information provided on this page represents TI's knowledge and belief as of the date that it is provided. TI bases its knowledge and belief on information provided by third parties, and makes no representation or warranty as to the accuracy of such information. Efforts are underway to better integrate information from third parties. TI has taken and continues to take reasonable steps to provide representative and accurate information but may not have conducted destructive testing or chemical analysis on incoming materials and chemicals. TI and TI suppliers consider certain information to be proprietary, and thus CAS numbers and other limited information may not be available for release.

In no event shall TI's liability arising out of such information exceed the total purchase price of the TI part(s) at issue in this document sold by TI to Customer on an annual basis.

TAPE AND REEL INFORMATION

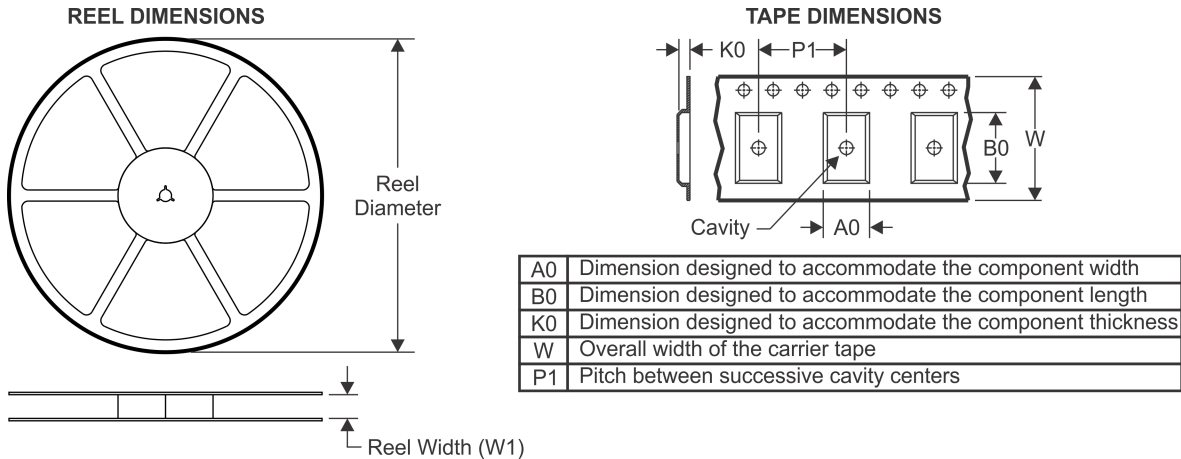

QUADRANT ASSIGNMENTS FOR PIN 1 ORIENTATION IN TAPE

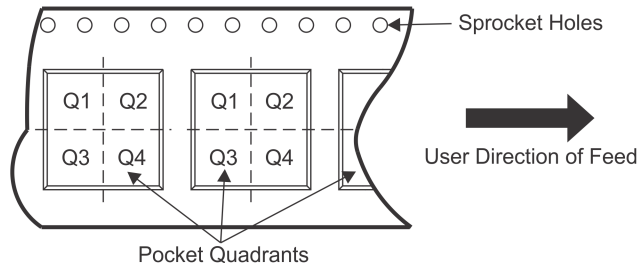

*All dimensions are nominal

Device	Package Type	Package Drawing	Pins	SPQ	Reel Diameter (mm)	Reel Width W1 (mm)	A0 (mm)	B0 (mm)	K0 (mm)	P1 (mm)	W (mm)	Pin1 Quadrant
TPS75501KTTR	DDPAK/TO-263	KTT	5	500	330.0	24.4	10.6	15.6	4.9	16.0	24.0	Q2
TPS75501KTTT	DDPAK/TO-263	KTT	5	50	330.0	24.4	10.6	15.6	4.9	16.0	24.0	Q2
TPS75515KTTR	DDPAK/TO-263	KTT	5	500	330.0	24.4	10.6	15.6	4.9	16.0	24.0	Q2
TPS75515KTTT	DDPAK/TO-263	KTT	5	50	330.0	24.4	10.6	15.6	4.9	16.0	24.0	Q2
TPS75518KTTR	DDPAK/TO-263	KTT	5	500	330.0	24.4	10.6	15.6	4.9	16.0	24.0	Q2
TPS75518KTTT	DDPAK/TO-263	KTT	5	50	330.0	24.4	10.6	15.6	4.9	16.0	24.0	Q2
TPS75525KTTR	DDPAK/TO-263	KTT	5	500	330.0	24.4	10.6	15.6	4.9	16.0	24.0	Q2
TPS75525KTTT	DDPAK/TO-263	KTT	5	50	330.0	24.4	10.6	15.6	4.9	16.0	24.0	Q2
TPS75533KTTR	DDPAK/TO-263	KTT	5	500	330.0	24.4	10.6	15.6	4.9	16.0	24.0	Q2
TPS75533KTTT	DDPAK/TO-263	KTT	5	50	330.0	24.4	10.6	15.6	4.9	16.0	24.0	Q2

PACKAGE MATERIALS INFORMATION

9-Sep-2013

TAPE AND REEL BOX DIMENSIONS

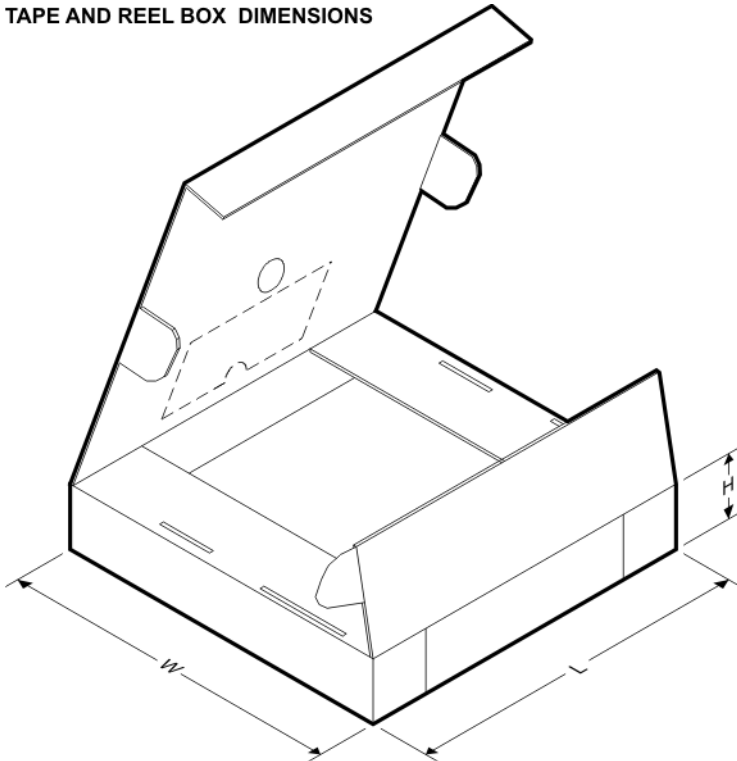

*All dimensions are nominal

Device	Package Type	Package Drawing	Pins	SPQ	Length (mm)	Width (mm)	Height (mm)
TPS75501KTTR	DDPAK/TO-263	KTT	5	500	367.0	367.0	45.0
TPS75501KTTT	DDPAK/TO-263	KTT	5	50	367.0	367.0	45.0
TPS75515KTTR	DDPAK/TO-263	KTT	5	500	367.0	367.0	45.0
TPS75515KTTT	DDPAK/TO-263	KTT	5	50	367.0	367.0	45.0
TPS75518KTTR	DDPAK/TO-263	KTT	5	500	367.0	367.0	45.0
TPS75518KTTT	DDPAK/TO-263	KTT	5	50	367.0	367.0	45.0
TPS75525KTTR	DDPAK/TO-263	KTT	5	500	367.0	367.0	45.0
TPS75525KTTT	DDPAK/TO-263	KTT	5	50	367.0	367.0	45.0
TPS75533KTTR	DDPAK/TO-263	KTT	5	500	367.0	367.0	45.0
TPS75533KTTT	DDPAK/TO-263	KTT	5	50	367.0	367.0	45.0

KC (R-PSFM-T5)

PLASTIC FLANGE-MOUNT PACKAGE

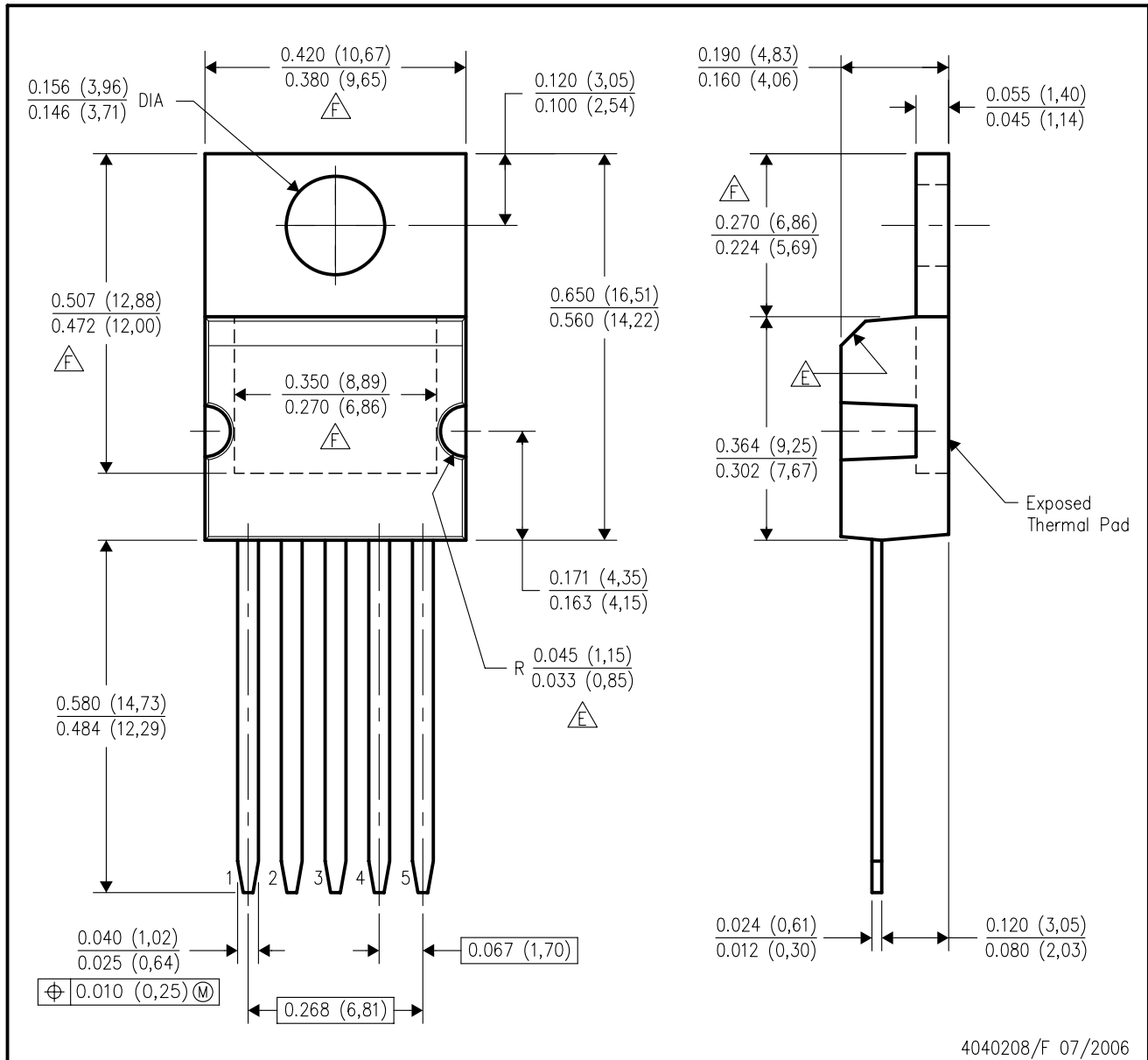

- NOTES:
- All linear dimensions are in inches (millimeters).
 - This drawing is subject to change without notice.
 - All lead dimensions apply before solder dip.
 - The center lead is in electrical contact with the mounting tab.
- $\triangle A$ These features are optional.
- $\triangle E$ Thermal pad contour optional within these dimensions.