

High-Efficiency Integrated Dimming LED Lighting Controller

Check for Samples: [TPS92070](#)

FEATURES

- **Advanced Integrated Dimming Interface**
- **Non-Dissipative TRIAC Dimmer Management**
- **Lamp-to-Lamp Uniformity During Dimming**
- **No Low-Frequency Photometric Ripple**
- **Exponential Dimming Profile**
- **Innovative Secondary-Side Feedback Eliminates Optocoupler Devices**
- **LED Current Regulation better than 5%**
- **Programmable Minimum LED Current**
- **Valley Switching and DCM Operation for Reduced EMI and Improved Efficiency**
- **Leading Edge Dimmer Detection**
- **Power Factor > 0.8**
- **Cycle-by-Cycle Current Limit Protection**
- **Low Start-Up and Standby Currents**
- **Integrated PWM MOSFET Driver**
- **Thermal Shutdown**
- **16-Pin, TSSOP package**

APPLICATIONS

- **LED Light Bulb Replacement**
- **LED Luminaires**
- **LED Downlights**
- **LED Wall Washers**

DESCRIPTION

The TPS92070 is an advanced PWM controller ideal for use in low-power, offline, LED lighting applications. The integrated dimming interface circuit of the TPS92070 features a non-dissipative dimmer trigger control circuit. The TPS92070 controller provides DC LED current with no photometric ripple effects. The DC current also results in higher efficacy of the LEDs. The TPS92070 provides exponentially controlled light output based on the external dimmer position. High power factor is achieved with a valley fill circuit. Once a leading-edge dimmer is detected, the TPS92070 sets an output to disable the PFC circuit and thus optimizes driver operation. The LED current sense precision error amplifier implements deep dimming. The TPS92070 current sensing scheme provides tight current regulation and eliminates the need for an optocoupler. The tight current regulation allows for strong color and intensity matching amongst individual bulbs or luminaires.

The TPS92070 also contains a variety of protection features including cycle-by-cycle peak-current limit, overcurrent protection, open-LED (output overvoltage) protection, undervoltage lockout, and thermal shutdown.



Please be aware that an important notice concerning availability, standard warranty, and use in critical applications of Texas Instruments semiconductor products and disclaimers thereto appears at the end of this data sheet.

TPS92070

SLUSAN1 –AUGUST 2011

www.ti.com

APPLICATION DIAGRAM

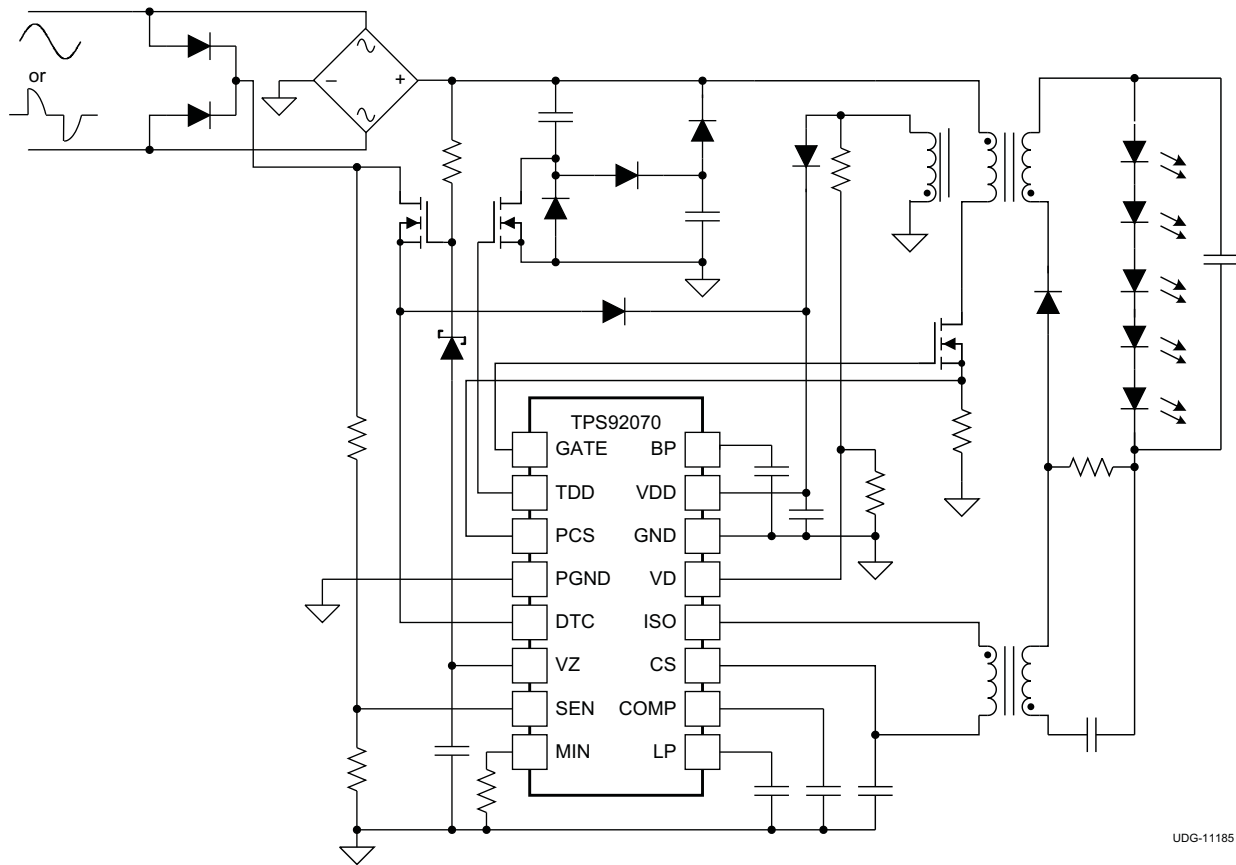

UDG-11185



This integrated circuit can be damaged by ESD. Texas Instruments recommends that all integrated circuits be handled with appropriate precautions. Failure to observe proper handling and installation procedures can cause damage.

ESD damage can range from subtle performance degradation to complete device failure. Precision integrated circuits may be more susceptible to damage because very small parametric changes could cause the device not to meet its published specifications.

ORDERING INFORMATION⁽¹⁾⁽²⁾

TEMPERATURE RANGE (T _J)	PACKAGE	PINS	TRANSPORT MATERIAL	UNITS	ORDERABLE NUMBER
-40°C to 140°C	Plastic TSSOP	16	Tube	70	TPS92070PW
			Tape and Reel	2000	TPS92070PWR

- (1) For the most current package and ordering information, see the Package Option Addendum at the end of this document, or see the TI website at www.ti.com.
- (2) Package drawings, thermal data, and symbolization are available at www.ti.com/packaging

ABSOLUTE MAXIMUM RATINGS⁽¹⁾⁽²⁾⁽³⁾

All voltages are with respect to GND, -40°C < T_J = T_A < 125°C, all currents are positive into and negative out of the specified terminal (unless otherwise noted)

			VALUE		UNITS
			MIN	MAX	
Supply voltage	VDD ⁽⁴⁾		-0.3	25.0	
Input voltages	ISO, CS, COMP, LP, MIN, SEN, PCS		-0.3	7.0	
	BP, GATE, TDD		-0.3	7.2	
	VD		-1.4	7.0	
	VZ, DTC ⁽⁵⁾		-0.3	20.0	
Input current	VZ (pulse < 1 ms)			5	mA
	BP		-0.5	0	
	DTC	Peak		30	
		Average		16	
	VDD			5	
Operating junction temperature ⁽⁶⁾			-40	140	°C
Storage temperature ⁽⁶⁾			-65	150	°C
Lead temperature (10 seconds)				260	°C

- (1) These are stress ratings only. Stress beyond these limits may cause permanent damage to the device. Functional operation of the device at these or any conditions beyond those indicated under *Recommended Operating Conditions* is not implied. Exposure to absolute maximum rated conditions for extended periods of time may affect device reliability
- (2) All voltages are with respect to GND.
- (3) All currents are positive into the terminal, negative out of the terminal.
- (4) VDD clamped at approximately 23 V. See [ELECTRICAL CHARACTERISTICS](#) table.
- (5) VZ clamped at approximately 12.5 V. See [ELECTRICAL CHARACTERISTICS](#) table.
- (6) Higher temperature may be applied during board soldering process according to the current JEDEC J-STD-020 specification with peak reflow temperatures not higher than classified on the device label on the shipping boxes or reels.

RECOMMENDED OPERATING CONDITIONS

Unless otherwise noted, all voltages are with respect to GND, $-40^{\circ}\text{C} < T_J = T_A < 125^{\circ}\text{C}$.

		MIN	TYP	MAX	UNIT
VDD	Input Voltage	9		21.5	V
VZ	Current	1		100	μA
R _{MIN}	Resistor from MIN to GND ⁽¹⁾	25		75	k Ω
R _{VD1}	Valley detect resistor from AUX winding to VD pin	50		200	k Ω
C _{VZ}	VZ bypass capacitor	1		4.7	nF
C _{BP}	BP capacitor	0.47	1		μF
C _{VDD}	VDD capacitor	10×C _{BP7}	4.7		μF
C _{VDD,BP}	VDD bypass capacitor, ceramic ⁽²⁾	0.1			μF

- (1) R_{MIN} values greater than 75K will produce lower minimum current values. However accuracy of the minimum current will degrade, and there may be flickering at very low values of I_{min}.
- (2) If a ceramic capacitor is used for C_{VDD} then this capacitor is not needed.

ELECTROSTATIC DISCHARGE (ESD) PROTECTION

	MAX	UNIT
ESD Rating, Human Body Model (HBM)	1.5	kV
ESD Rating, Charged Device Model (CDM)	500	V

ELECTRICAL CHARACTERISTICS

Unless otherwise stated, $-40^{\circ}\text{C} < T_A < 125^{\circ}\text{C}$, $T_J = T_A$, V_{VDD} = 12 V, GND = 0 V, I_{VZ} = 50 μA , R_{MIN} = 71.5 k Ω , C_{VDD} = 4.7 μF , C_{BP} = 1 μF , C_{LP} = 220nF

PARAMETER		TEST CONDITIONS	MIN	TYP	MAX	UNITS
BIAS and STARTUP						
I _{START}	VZ startup current	V _{VDD} = 7 V, Measured I _{VZ}		1.0	10	μA
V _{VZ}	VZ voltage	V _{VDD} = 7 V, 15 $\mu\text{A} < I_{VZ} < 100 \mu\text{A}$	11.5	12.5	13.5	V
I _{VDD}	VDD startup current	V _{VDD} = 7.5 V		134	240	μA
	Standby current	V _{LP} = 0 V, V _{SEN} = 0 V		750	1500	
	Switching current	f _{GATE} = 138 kHz, GATE – unloaded		1880	2500	
V _{VDD(uvlo)}	VDD UVLO threshold	Measured at VDD (falling)	7	7.88	8.4	V
V _{VDD(ovp)}	VDD clamp and OVP	Measured at VDD (rising)	21.5	23.5	25	V
R _{VZ(ovp)}	OVP VZ discharge resistance	V _{VDD} = V _{VDD(ovp)} , VZ = 3 V		4.8		k Ω
V _{BP}	BP Regulation voltage	9 V < V _{VDD} < 19V, I _{BP} = -0 μA	6.7	7	7.2	V
DIMMER TRIGGER CIRCUIT						
V _{SEN(hi)}	Dimmer sense thresholds	Measured at SEN (rising)	4.75	5	5.25	V
V _{SEN(lo)}		Measured at SEN (falling)	0.9	1	1.10	
V _{SEN(clamp)}	SEN Clamp voltage	I _{SEN} = 100 μA	5.75	6	6.25	V
I _{DTC(lkg)}	DTC to PGND leakage current	V _{DTC} = 12 V, V _{SEN} > V _{SEN(hi)}		40	100	nA
R _{DTC(pgnd)}	DTC to PGND resistance	V _{DTC} = 3 V, V _{SEN} (falling), V _{SEN(lo)} < V _{SEN} < V _{SEN(hi)}	16	20	25	k Ω
		V _{DTC} = 3 V, V _{SEN} (rising), V _{SEN} < V _{SEN(hi)}	100	156	300	Ω
		V _{SEN} < V _{SEN(lo)}	100	156	300	Ω
CURRENT SETPOINT						
V _{MIN}	MIN regulation voltage			2.5		
R _{OUT(lp)}	LP output resistance			500		k Ω
V _{OH(lp)}	LP Maximum voltage level	V _{SEN} = 6 V, I _{LP} = 0 μA	2.9	3	3.1	V
V _{OL(lp)}	LP Minimum voltage level	V _{SEN} = 0 V, I _{LP} = 0 μA	-0.02 5	0	0.025	V

ELECTRICAL CHARACTERISTICS (continued)

Unless otherwise stated, $-40^{\circ}\text{C} < T_A < 125^{\circ}\text{C}$, $T_J = T_A$, $V_{\text{VDD}} = 12\text{ V}$, $\text{GND} = 0\text{ V}$, $I_{\text{VZ}} = 50\text{ }\mu\text{A}$, $R_{\text{MIN}} = 71.5\text{ k}\Omega$, $C_{\text{VDD}} = 4.7\text{ }\mu\text{F}$, $C_{\text{BP}} = 1\text{ }\mu\text{F}$, $C_{\text{LP}} = 220\text{ nF}$

PARAMETER		TEST CONDITIONS	MIN	TYP	MAX	UNITS
ERROR AMPLIFIER						
V_{IOS}	Input offset voltage	$5\text{ mV} < V_{\text{CS}} < 100\text{ mV}$, $V_{\text{COMP}} = 3\text{ V}$		± 500		μV
$V_{\text{COMP(min)}}$	Minimum COMP clamp voltage	$V_{\text{CS}} = 150\text{ mV}$, $V_{\text{LP}} < 3\text{ V}$	1.45	1.53	1.60	V
$V_{\text{COMP(max)}}$	Maximum COMP clamp voltage	$V_{\text{CS}} < 100\text{ mV}$, $V_{\text{LP}} > 2.1\text{ V}$	3.6	3.7	3.8	V
$V_{\text{CS(min)}}$	Minimum CS reference voltage	$V_{\text{LP}} = 0$, $R_{\text{MIN}} = 71.5\text{ k}\Omega$, $T_A = 25^{\circ}\text{C}$	2.835	3.15	3.465	mV
$V_{\text{CS(max)}}$	Maximum CS reference voltage	$V_{\text{LP}} > 2.1\text{ V}$, $T_A = 25^{\circ}\text{C}$	97	100	103	mV
MODULATION						
$f_{\text{CLAMP(max)}}$	Maximum frequency clamp	Measured at GATE, $V_{\text{COMP}} = 3.5\text{ V}$, $T_A = 25^{\circ}\text{C}$	132	138	146	kHz
$f_{\text{CLAMP(min)}}$	Minimum frequency clamp	Measure at GATE, $V_{\text{COMP}} = 1.53\text{ V}$, $V_{\text{VD}} = 0\text{ V}$, $T_A = 25^{\circ}\text{C}$	10	20	30	
VALLEY DETECT						
V_{DCLAMP}	VD clamp	Measured when GATE is high, $I_{\text{VD}} = -15\text{ }\mu\text{A}$		-560		mV
		Measured when GATE is low and VD is falling		-125		
$V_{\text{VD(en)}}$	VD enable threshold	Minimum peak of resonant valley, $V_{\text{COMP}} = 1.8\text{ V}$	600			mV
$V_{\text{VD(zc)}}$	Zero-crossing detect threshold	Measured at VD (falling)	80	100	135	mV
$t_{\text{VD(vw)}}$	Valley wait timer	$V_{\text{COMP}} > V_{\text{MINF_DET}}$, $V_{\text{VD}} = 0\text{ V}$, wait time for next PWM pulse with zero-crossing detected	10	12.7	14	μs
$I_{\text{VD(min)}}$	Current required for valley detection		-50			μA
OVERCURRENT PROTECTION						
$V_{\text{PCS(oc)}}$	Over current limit	Measure at PCS (rising), $V_{\text{COMP}} = 4\text{ V}$	670	700	750	mV
$t_{\text{PCS_G1(oc)}}$	Propagation delay	Measured between PCS and GATE falling	10	64	190	ns
PWM COMPARATOR						
t_{LEB}	Leading edge blanking	Measured at GATE, $V_{\text{COMP}} = 3.5\text{ V}$	180	220	300	ns
$V_{\text{PWM(max)}}$	PWM thresholds	$V_{\text{COMP}} = V_{\text{COMP(max)}}$		600	650	mV
V_{PWM}		$V_{\text{COMP}} = 3.5\text{ V}$		460	500	
$V_{\text{PWM(min)}}$		Measured at PCS rising, $\text{COMP} \leq 2\text{ V}$		40	65	
$t_{\text{PCS_G1(cl)}}$	Propagation delay	Measured between PCS and GATE falling	10	54	120	ns
LED ISOLATED CURRENT SENSE						
$R_{\text{ISO(pd)}}$	Pull down resistance	GATE is high	240	270	350	Ω
PWM OUTPUTS						
$V_{\text{GATE(oh)}}$	Output voltage high	Measured at GATE	6.7	7	7.2	V
$V_{\text{GATE(ol)}}$	Output voltage low		-0.01	0	0.01	
$t_{\text{FALL(pwm)}}$	Fall time	$C_{\text{GATE}} = 1\text{ nF}$, $T_A = 25^{\circ}\text{C}$		43	70	ns
$t_{\text{RISE(pwm)}}$	Rise time	$C_{\text{GATE}} = 1\text{ nF}$, $T_A = 25^{\circ}\text{C}$		105	155	
TRIAC DIMMER DETECTION						
$V_{\text{TDD(oh)}}$	Output voltage high	Measured at TDD	6.7	7	7.2	V
$V_{\text{TDD(ol)}}$	Output voltage low		-0.01	0	0.01	
$t_{\text{FALL(tdd)}}$	Fall time	$C_{\text{TDD}} = 1\text{ nF}$		120	190	ns
$t_{\text{RISE(tdd)}}$	Rise time	$C_{\text{TDD}} = 1\text{ nF}$		130	220	
$t_{\text{DLY_1V_5V}}$	Minimum delay from 1V to 5V SEN signal transitions for no dimmer detection		105	135	170	μs

DEVICE INFORMATION
FUNCTIONAL BLOCK DIAGRAM

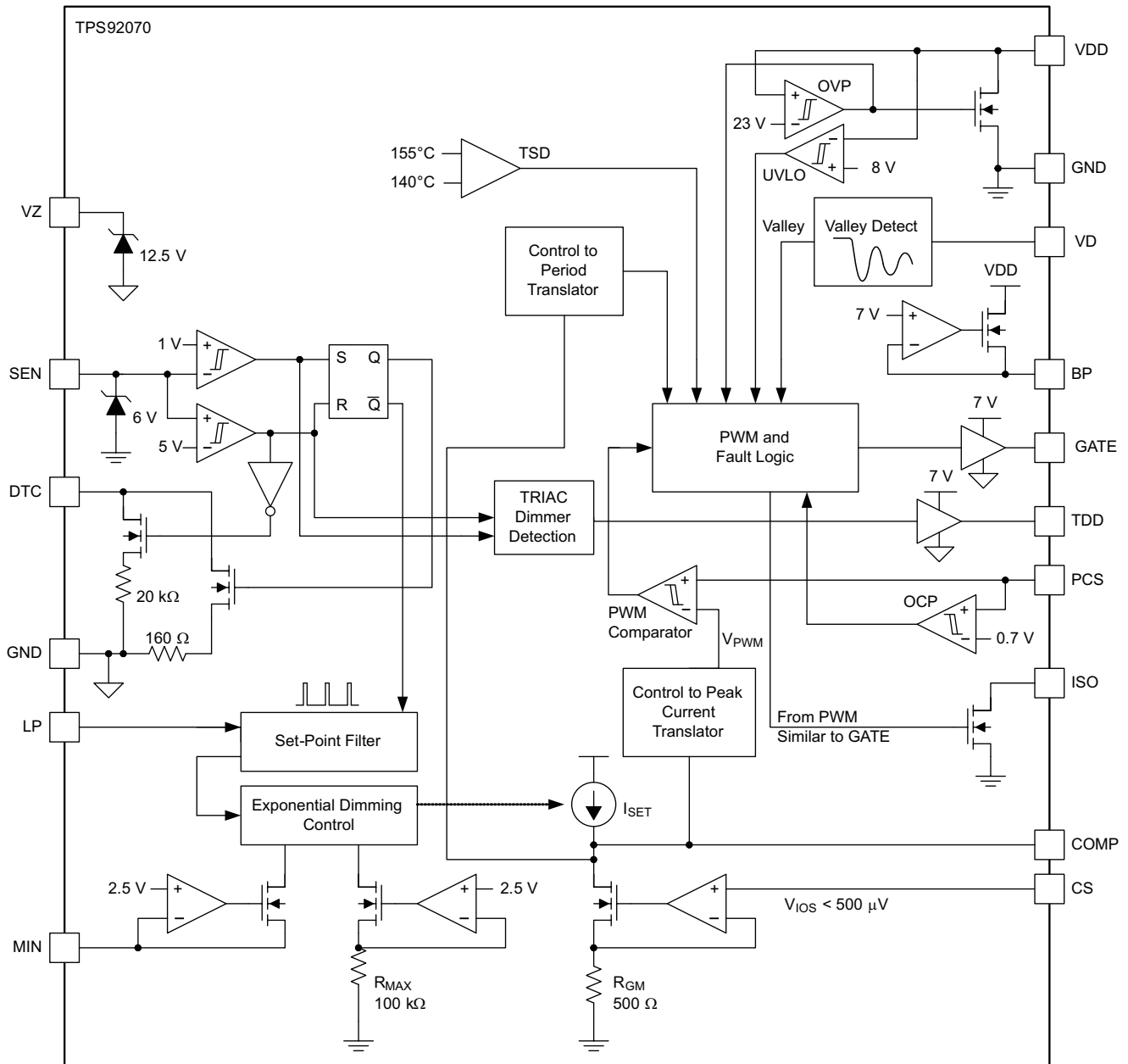

UDG-11186

**TPS92070
PW (TSSOP) PACKAGE
(TOP VIEW)**

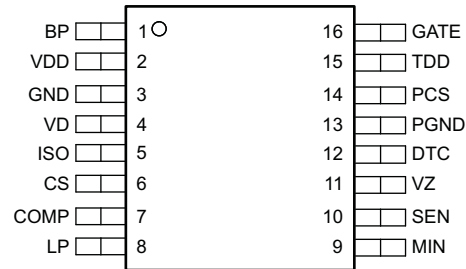

PIN DESCRIPTIONS

PIN		DESCRIPTION
NAME	NO.	
BP	1	Connect a 1-uF ceramic capacitor to GND to bypass the internal voltage regulator.
COMP	7	Loop compensation output. Connect the loop compensation components between this pin and GND
CS	6	LED current sense feedback and positive input terminal of the error amplifier.
DTC	12	Dimmer trigger control input. Connect this pin to the source of the HV N-channel MOSFET cascode device of the DTC circuit.
GATE	16	PWM drive signal output. Connect to flyback power MOSFET.
GND	3	Ground for internal circuitry
ISO	5	Inverting input of secondary side current sense comparator and isolation transformer buffer. Connect to GND for non-isolated applications.
LP	8	Pole for DTC low pass filter. Connect a capacitor to GND to set the response time of the dimming level detection circuit.
MIN	9	Minimum current programming input. Connect a resistor to GND to set the minimum LED current.
PCS	14	Primary current sense input. Connected to shunt resistor for primary side current sense.
PGND	13	Power ground for GATE Driver. Connected to GND ⁽¹⁾
SEN	10	Dimmer sense input. An internal window comparator continuously monitors this pin to determine the dimmer setting.
TDD	15	TRIAC dimmer detect. Drives bypass FET in Valley Fill PFC when dimmer is detected. For non PFC applications, leave this pin open
VD	4	Valley detect input. Connect to the Aux winding through a resistor divider.
VDD	2	Provides power to the device. Connect a bypass capacitor directly to GND. See RECOMMENDED OPERATING CONDITIONS for suggested values.
VZ	11	Voltage clamp. This pin clamps the maximum voltage on the gate of the external HV DTC N-channel MOSFET.

(1) See Application Section for layout recommendations

TYPICAL CHARACTERISTICS

Unless otherwise stated, $-40^{\circ}\text{C} \leq T_A = T_J \leq +125^{\circ}\text{C}$, $V_{\text{VDD}} = 12\text{ V}$, $\text{GND} = 0\text{V}$, $I_{\text{VZ}} = 50\ \mu\text{A}$, $R_{\text{MIN}} = 71.5\ \text{k}\Omega$, $C_{\text{VDD}} = 10\ \mu\text{F}$, $C_{\text{VZ}} = 1\ \text{nF}$, $C_{\text{LP}} = 220\ \text{nF}$

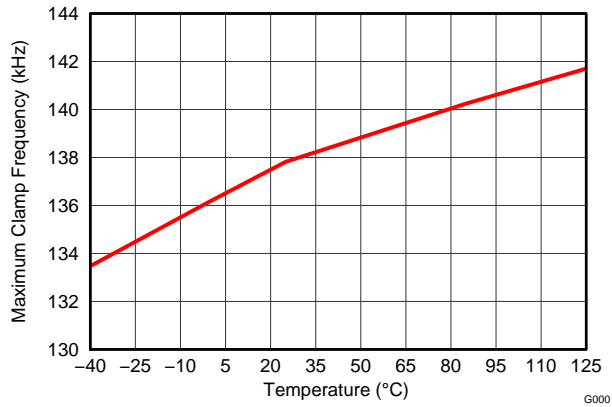

Figure 1. Maximum Clamp Frequency vs. Temperature

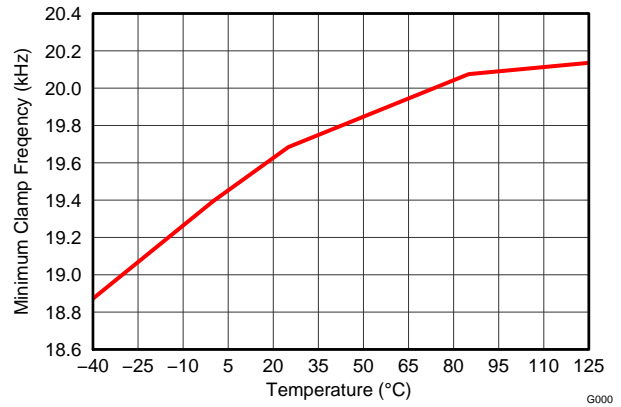

Figure 2. Minimum Clamp Frequency vs. Temperature

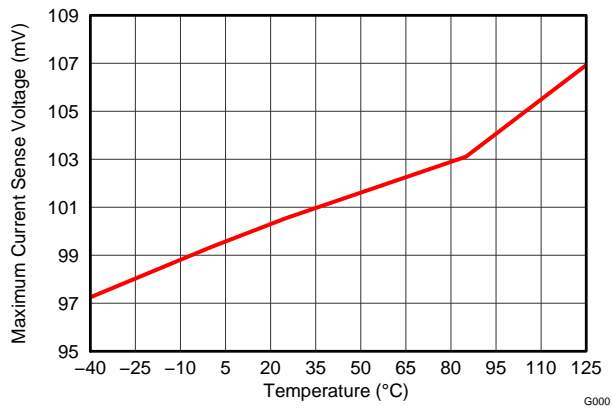

Figure 3. Maximum Current Sense Voltage vs. Temperature

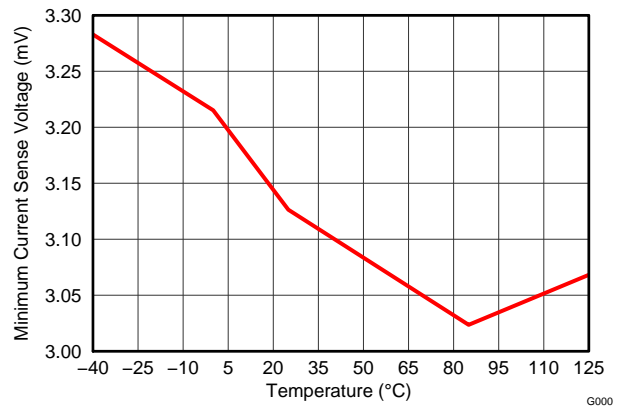
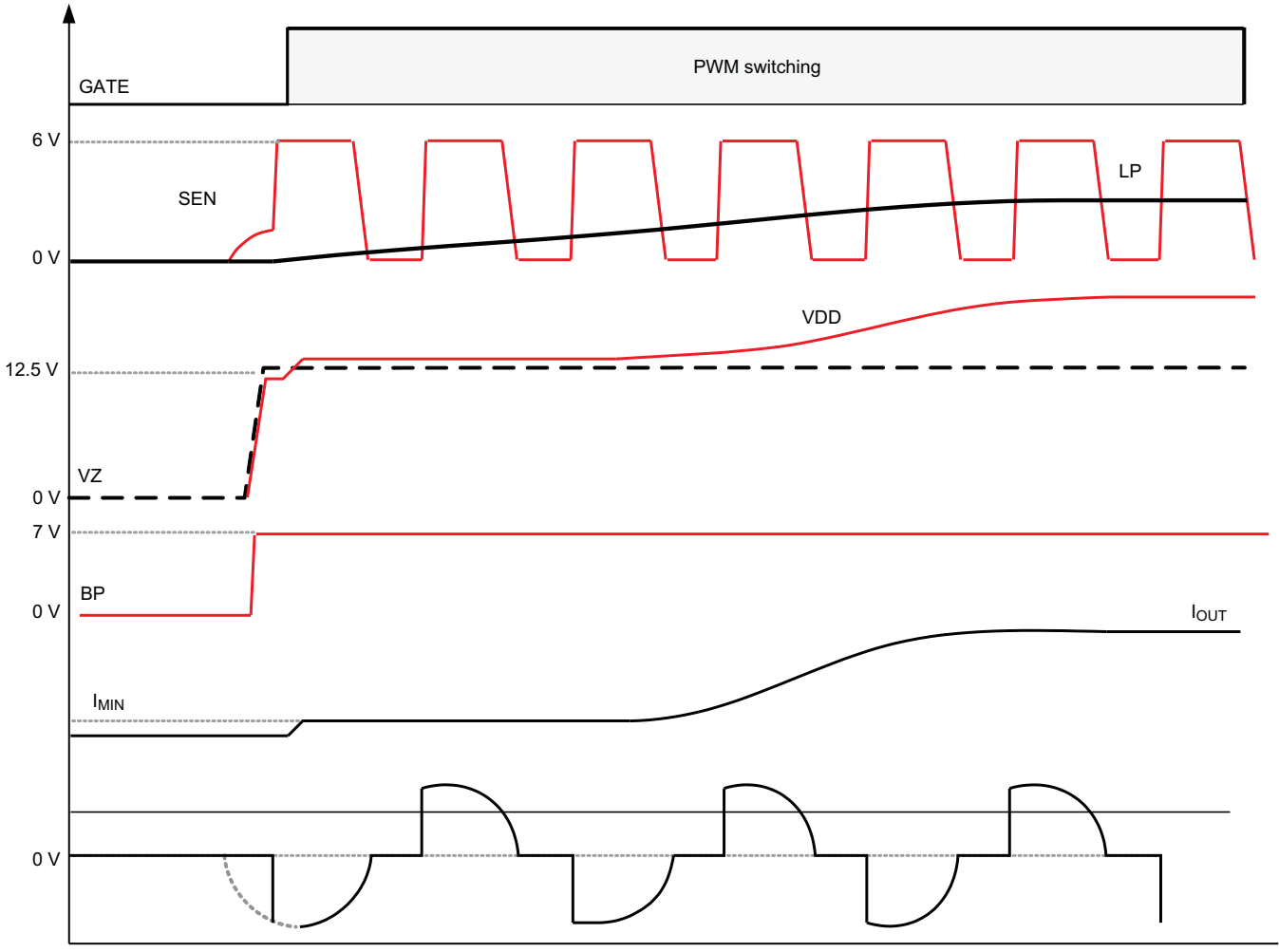

Figure 4. Minimum Current Sense Voltage vs. Temperature

APPLICATIONS

STARTUP BIAS AND UVLO

During powerup when VDD is less than the UVLO threshold of 8 V, the VZ pin is trickle charged with $I_{VZ(start)}$ of approximately 10 μ A through the startup-resistor connected to the bulk rectified voltage. As VZ is being charged, VDD tracks VZ (less V_{GSTH}) through the external cascode HV MOSFET (Q1) supplying a VDD startup current of 135 μ A. Once VZ reaches the TPS92070 zener clamp regulation level of 12.5 V, the device enters into a stand-by mode during which the dimmer trigger circuit (DTC), set-point filter, 7-V bias regulator, and a minimal amount of housekeeping circuitry is active. The TPS92070 remains in this state until the SEN pin exceeds 5 V indicating that adequate line voltage is present, either through TRIAC firing, or line voltage presence. The typical start-up waveforms are shown in Figure 5.



UDG-11187

Figure 5. Typical Startup Waveforms for a TRIAC Triggered $V_{IN(ac)}$ Input

DTC and PHASE DETECTION

The DTC pin is a current sink which loads the dimmer with approximately 20 mA during the zero-crossing of the AC line to ensure that the TRIAC is reliably triggered. This current sink is switched on when the voltage on the SEN pin is below 5 V. The setpoint filter in conjunction with the SEN and LP pins is used to determine the firing angle of the TRIAC dimmer (if any) connected to the input of the LED driver. An internal window comparator monitors the SEN (dimmer sense input) pin and the resulting duty-cycle is transformed into a voltage at the LP pin using the LP filter. The relation between the TRIAC firing angle and the LP voltage is shown in Figure 6. It illustrates the conversion of the TRIAC firing angle to LP voltage and exponential dimming control of I_{SET} based on internal control voltage. As the voltage on the LP varies from 0 V to 3 V based on the mapping of 0% to 100% SEN duty-cycle, an internal control voltage is linearly modulated by TPS92070 from 400 mV to 200 mV.

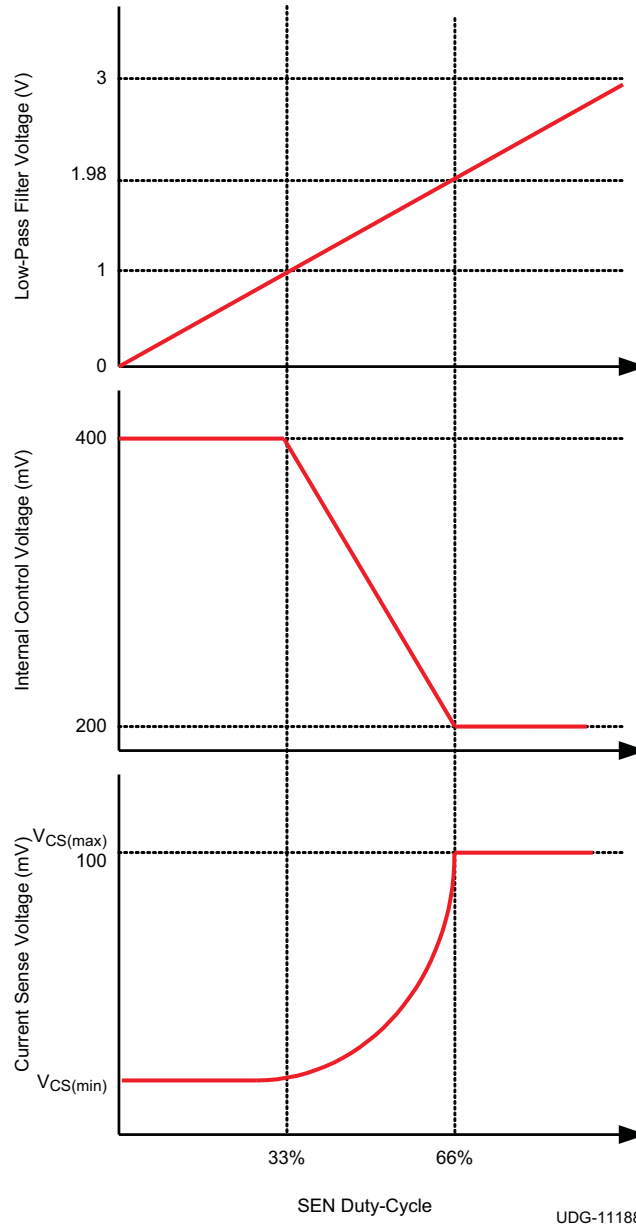

Figure 6. TRIAC Firing Angle vs. Low-Pass Filter Voltage

The internal control voltage, V_{CTRL} is clamped to 0.4 V for $LP < 1$ V and clamped to 0.2 V for $LP > 1.98$ V . As the control voltage is linearly modulated between 0.4 V and 0.2 V, the current sense reference voltage V_{CS} is exponentially controlled between the pre-set maximum of 100 mV and the externally programmed minimum limit of V_{CS_MIN} . The current setpoint level, V_{CS_MIN} is programmed by R_{MIN} .

$$V_{CS(min)} = \frac{225}{R_{MIN}} \quad (1)$$

The exponential control of the set-point current extends the dimming control range and enables up to two decades of LED current-programming between the $V_{CS(min)}$ and $V_{CS(max)} = 100$ mV levels.

LED CURRENT SENSE

The secondary-side LED current is sensed using the CS pin and tightly regulated using the low-offset (500 μ V) transconductance amplifier. The transconductance (g_M) of the amplifier is internally set to approximately $g_M = 1/500$ S. In the direct current-sense mode (non-isolated), the ISO pin is connected to GND. In the isolated-mode, the secondary-side LED current is sensed using a small transformer with the secondary of the transformer connected between CS and ISO pins as shown in Figure 7. The ISO pin has a switched pull-down resistance of 270 Ω .

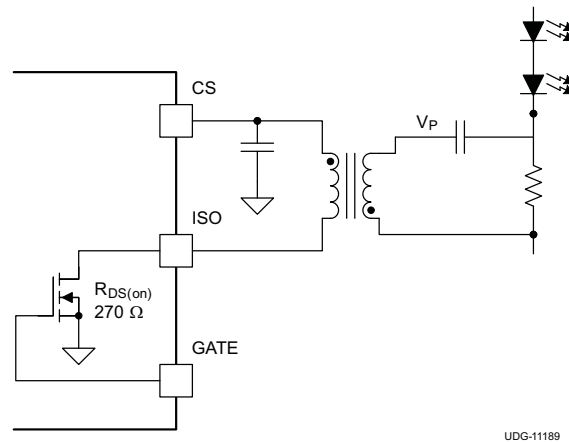

Figure 7. Isolated Current Sense

MODULATION

The internal I_{SET} current and RGM sets a reference input for the transconductance current sense amplifier which controls the voltage on the COMP pin. The COMP pin is used for loop compensation. The voltage on the COMP pin modulates the peak of the primary current and the switching frequency (frequency modulation) of the flyback converter. The modulation on the primary current and the switching frequency are shown in Figure 8. The peak of the primary current is modulated by varying the threshold on the PWM comparator. The threshold is modulated from 0.6 V to 0.065 V while the switching frequency varies between 20 kHz and 138 kHz as COMP pin varies from 3.7 V to 2.6 V. The maximum COMP pin voltage is clamped at 3.7 V allowing the maximum cycle-by-cycle peak current limit PWM threshold to be 0.6 V. The switching frequency is linearly modulated from 138 kHz to 20 kHz with the PWM threshold clamped at 0.065 V as the COMP pin varies from 2.6 V to 1.63 V. The minimum frequency is clamped at 20 kHz and TPS92070 enters the minimum frequency detect state for $COMP < 1.6$ V. The minimum voltage on the COMP is clamped at 1.53 V. The PWM threshold is related to the COMP pin voltage as shown in Equation 2 and Equation 3.

For $2.6 \leq V_{COMP} \leq 3.7$,

$$V_{PWM} = \frac{V_{COMP} - 2.5}{2} \quad (2)$$

For $V_{COMP} < 2.6$ V,

$$V_{PWM} = 0.065 \quad (3)$$

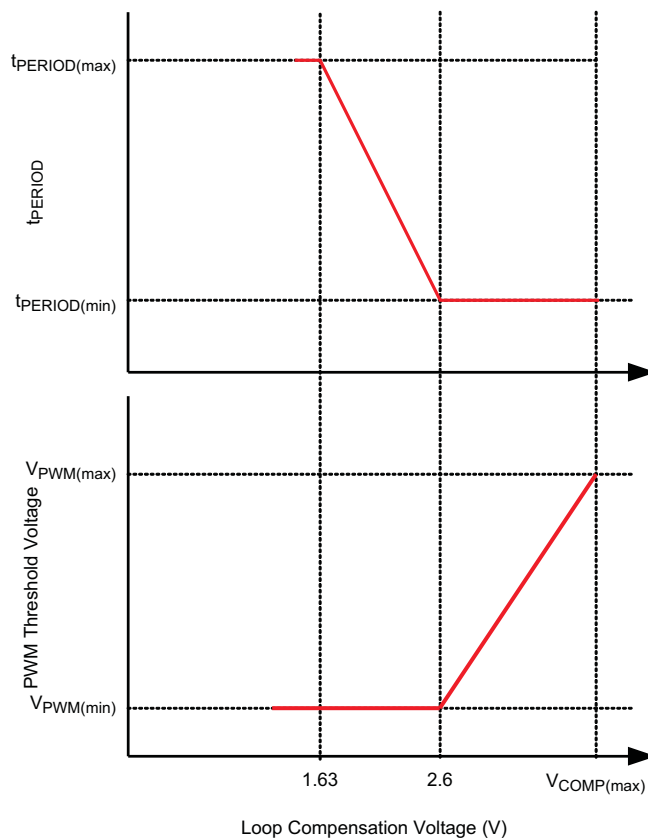

UDG-11194

Figure 8. Switching Period and PWM Threshold Modulation Based on COMP pin Voltage

PRIMARY CURRENT SENSE

The primary current is sensed by monitoring the voltage developed across an external current-sense resistor connected between the source of the external HV MOSFET and PGND. The PCS pin is used for monitoring the voltage and it is then compared with the PWM threshold (V_{PWM}). The PWM comparator has a leading-edge blanking time of 220 ns to avoid any false-tripping of the comparator due to capacitive charge spikes on the PCS pin. The GATE output is pulled low once the PCS pin reaches the PWM threshold.

VALLEY DETECT

TPS92070 ensures that the flyback converter always operates in either DCM or QR mode of operation and initiates a new PWM switching cycle only after the energy in the flyback transformer is completely reset to zero. This is accomplished by monitoring the auxiliary winding waveform using a resistive divider connected to the VD pin. The TPS92070 initiates a new switching cycle based on the following conditions:

- For normal operation with $1.63\text{ V} \leq V_{\text{COMP}} \leq 3.7\text{ V}$, a new PWM switching cycle is initiated when the internal timer t_{PERIOD} has expired and the next valley is detected. The VD pin must go below 100 mV ($V_{\text{VD(zc)}}$) prior to valley detection to enable the valley detector circuit.
- In the minimum frequency clamp state when $V_{\text{COMP}} < 1.63\text{ V}$, the switching period is fixed at $t_{\text{PERIOD(max)}}$ (corresponding to $f_{\text{CLAMP(min)}}$) and the valley detector is disabled.
- The relationship of t_{PERIOD} to the switching frequency is shown in [Equation 4](#) and [Equation 5](#).

$$f_{\text{CLAMP(max)}} = \frac{1}{t_{\text{PERIOD(min)}}} \quad (4)$$

$$f_{\text{CLAMP(min)}} = \frac{1}{t_{\text{PERIOD(max)}}} \quad (5)$$

By turning on the flyback power switch at the resonant valley, the switching losses are reduced thereby enabling higher efficiency. The voltage at the VD pin is clamped at -0.56 V during the negative excursions on the AUX winding when GATE is high. When GATE is low and during the resonant valley detection, the VD pin is clamped at -0.2 V . The interface to the VD pin to the AUX winding is shown in [Figure 9](#). The TPS92070 requires that the positive peak of the resonant ring at the VD pin is higher than 0.6 V ($V_{\text{VD(en)}}$) to ensure that the valley-detect circuit is enabled for detection on the falling edge when $V_{\text{COMP}} > 1.63\text{ V}$. Hence, R_{VD2} need to be selected in such a way that this condition is met for all AUX voltages when $V_{\text{COMP}} > 1.63\text{ V}$. A current $I_{\text{VD(min)}}$ of at least $50\text{ }\mu\text{A}$ must be drawn from the VD pin when the GATE is high to ensure proper valley detection. This requirement determines the value of R_{VD1} . The waveforms associated with the valley detect are shown in [Figure 10](#). If the voltage at the AUX winding is not sufficient for valley detection when $V_{\text{COMP}} > 1.63\text{ V}$, an internal valley wait timer of $12.7\text{ }\mu\text{s}$ ($t_{\text{VD(vw)}}$) expires after the t_{PERIOD} times out. The time out of the valley wait timer would initiate a new PWM switching pulse following the 100 mV threshold crossing on the VD pin.

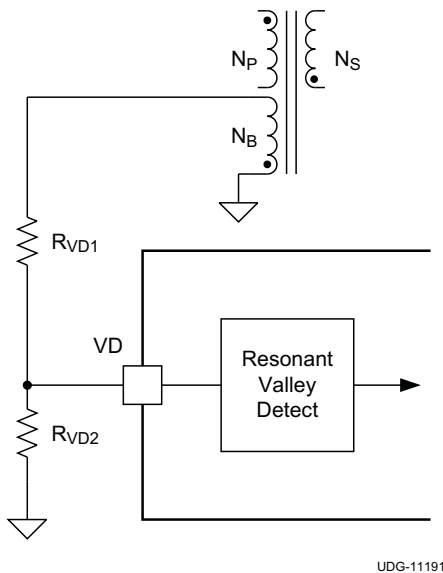

Figure 9. Auxiliary Winding Interface to VD

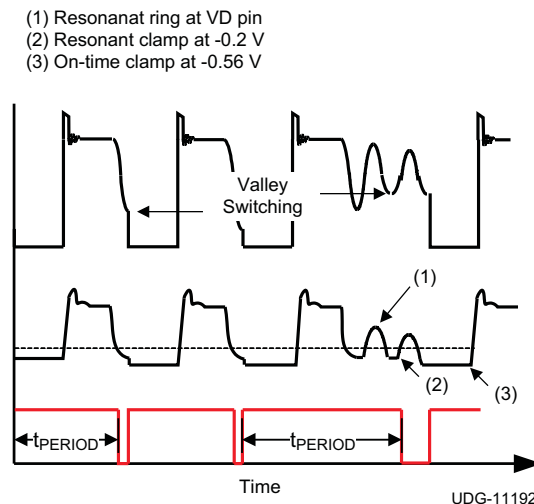

Figure 10. HV MOSFET Drain and VD Waveforms

TRIAC DIMMER DETECT

The TDD pin is used to drive an external by-pass FET that disables valley-fill PFC when a dimmer is detected by TPS92070. The TDD pin is set to logic high state ($V_{TDD(oh)} = 7\text{ V}$) as the part is powered up and if no dimmer is detected by continuously sensing the SEN pin, the TDD pin is then reset to logic low ($V_{TDD(ol)} = 0\text{ V}$). The presence of a dimmer is detected by monitoring the time delay in a window between 1 V and 5 V comparators that are monitoring the SEN pin. If the rise time from 1 V to 5 V is greater than 135 μs for four consecutive half-line cycles, direct connection to the AC line without dimmer is assumed, and the TDD output goes low. Otherwise the TDD pin remains high. If the TDD pin is low and the delay time ($t_{DLY_1V_5V}$) is detected to be less than 135 μs , for four consecutive half-line cycles, the TDD pin goes high once the SEN pin falls below 1 V indicating dimmer detection.

PROTECTION FEATURES

Output Over Voltage Protection (OVP)

Output (secondary-side) overvoltage protection / open LED detection is achieved by disabling the controller whenever the VDD voltage rises enough to trigger its internal 23 V clamp. Upon OVP detection, GATE is pulled low and the TDD pin is reset to logic-high state. The TPS92070 is disabled and an internal pull-down resistor ($R_{VZ(oVP)}$) discharges the VZ pin, until the VDD voltage drops below the UVLO threshold when a restart is triggered.

Overcurrent Protection (OCP)

Overcurrent faults are detected when the PCS pin exceeds the internal 700-mV threshold. Upon the detection of an OCP condition, the GATE signal is pulled low, and the LP pin voltage is reset to 0 V corresponding to the minimum LED output condition. GATE switching and current regulation resumes from the minimum LED light setting once the SEN pin crosses the 5 V.

Thermal Shutdown (TSD)

TPS92070 is disabled if the junction temperature of the part exceeds approximately 155°C and enters into the restart mode where the VZ pin is discharged until VDD falls below the UVLO threshold. The device stays in this restart mode until the junction temperature falls below approximately 140°C when it resumes normal operation with the light output preset to the minimum setting.

PCB Layout

Use good layout practices when constructing the PCB. Maintain the location of bypass components close to the pins being bypassed. Route power ground (PGND) separate from signal ground (GND) to keep the high current paths and the small signal paths separate. Connect PGND to GND at a single point, preferably under the device.

PACKAGING INFORMATION

Orderable Device	Status (1)	Package Type	Package Drawing	Pins	Package Qty	Eco Plan (2)	Lead/Ball Finish	MSL Peak Temp (3)	Op Temp (°C)	Top-Side Markings (4)	Samples
TPS92070PW	ACTIVE	TSSOP	PW	16	90	Green (RoHS & no Sb/Br)	CU NIPDAU	Level-1-260C-UNLIM	-40 to 125	TP92070	Samples
TPS92070PWR	ACTIVE	TSSOP	PW	16	2000	Green (RoHS & no Sb/Br)	CU NIPDAU	Level-1-260C-UNLIM	-40 to 125	TP92070	Samples

(1) The marketing status values are defined as follows:

ACTIVE: Product device recommended for new designs.

LIFEBUY: TI has announced that the device will be discontinued, and a lifetime-buy period is in effect.

NRND: Not recommended for new designs. Device is in production to support existing customers, but TI does not recommend using this part in a new design.

PREVIEW: Device has been announced but is not in production. Samples may or may not be available.

OBSOLETE: TI has discontinued the production of the device.

(2) Eco Plan - The planned eco-friendly classification: Pb-Free (RoHS), Pb-Free (RoHS Exempt), or Green (RoHS & no Sb/Br) - please check <http://www.ti.com/productcontent> for the latest availability information and additional product content details.

TBD: The Pb-Free/Green conversion plan has not been defined.

Pb-Free (RoHS): TI's terms "Lead-Free" or "Pb-Free" mean semiconductor products that are compatible with the current RoHS requirements for all 6 substances, including the requirement that lead not exceed 0.1% by weight in homogeneous materials. Where designed to be soldered at high temperatures, TI Pb-Free products are suitable for use in specified lead-free processes.

Pb-Free (RoHS Exempt): This component has a RoHS exemption for either 1) lead-based flip-chip solder bumps used between the die and package, or 2) lead-based die adhesive used between the die and leadframe. The component is otherwise considered Pb-Free (RoHS compatible) as defined above.

Green (RoHS & no Sb/Br): TI defines "Green" to mean Pb-Free (RoHS compatible), and free of Bromine (Br) and Antimony (Sb) based flame retardants (Br or Sb do not exceed 0.1% by weight in homogeneous material)

(3) MSL, Peak Temp. -- The Moisture Sensitivity Level rating according to the JEDEC industry standard classifications, and peak solder temperature.

(4) Multiple Top-Side Markings will be inside parentheses. Only one Top-Side Marking contained in parentheses and separated by a "~" will appear on a device. If a line is indented then it is a continuation of the previous line and the two combined represent the entire Top-Side Marking for that device.

Important Information and Disclaimer: The information provided on this page represents TI's knowledge and belief as of the date that it is provided. TI bases its knowledge and belief on information provided by third parties, and makes no representation or warranty as to the accuracy of such information. Efforts are underway to better integrate information from third parties. TI has taken and continues to take reasonable steps to provide representative and accurate information but may not have conducted destructive testing or chemical analysis on incoming materials and chemicals. TI and TI suppliers consider certain information to be proprietary, and thus CAS numbers and other limited information may not be available for release.

In no event shall TI's liability arising out of such information exceed the total purchase price of the TI part(s) at issue in this document sold by TI to Customer on an annual basis.

TAPE AND REEL INFORMATION



QUADRANT ASSIGNMENTS FOR PIN 1 ORIENTATION IN TAPE



*All dimensions are nominal

Device	Package Type	Package Drawing	Pins	SPQ	Reel Diameter (mm)	Reel Width W1 (mm)	A0 (mm)	B0 (mm)	K0 (mm)	P1 (mm)	W (mm)	Pin1 Quadrant
TPS92070PWR	TSSOP	PW	16	2000	330.0	12.4	6.9	5.6	1.6	8.0	12.0	Q1

TAPE AND REEL BOX DIMENSIONS



*All dimensions are nominal

Device	Package Type	Package Drawing	Pins	SPQ	Length (mm)	Width (mm)	Height (mm)
TPS92070PWR	TSSOP	PW	16	2000	367.0	367.0	35.0

PW (R-PDSO-G16)

PLASTIC SMALL OUTLINE

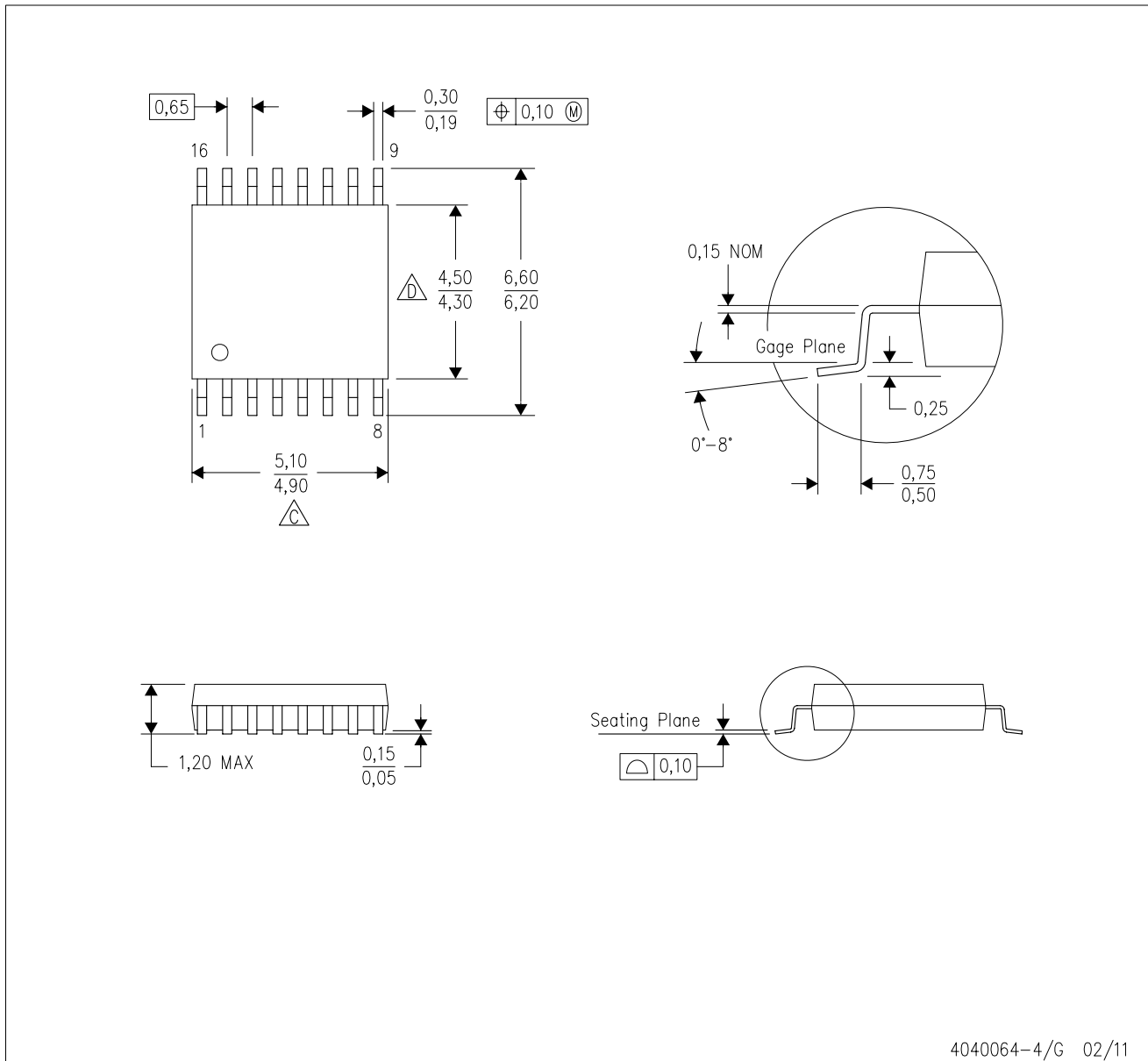

4040064-4/G 02/11

- NOTES:
- A. All linear dimensions are in millimeters. Dimensioning and tolerancing per ASME Y14.5M-1994.
 - B. This drawing is subject to change without notice.
 - C. Body length does not include mold flash, protrusions, or gate burrs. Mold flash, protrusions, or gate burrs shall not exceed 0,15 each side.
 - D. Body width does not include interlead flash. Interlead flash shall not exceed 0,25 each side.
 - E. Falls within JEDEC MO-153

PW (R-PDSO-G16)

PLASTIC SMALL OUTLINE

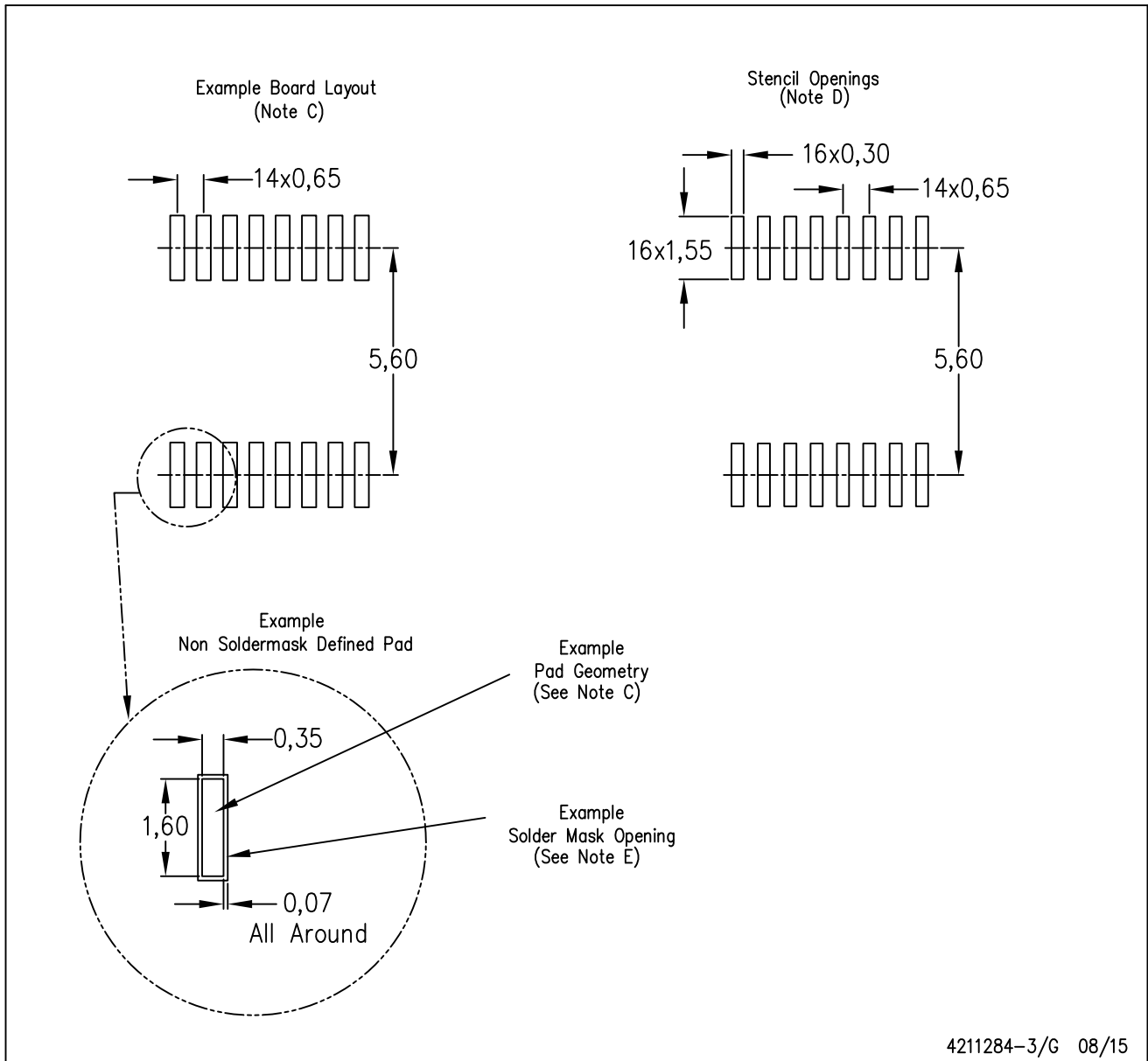

- NOTES:
- All linear dimensions are in millimeters.
 - This drawing is subject to change without notice.
 - Publication IPC-7351 is recommended for alternate designs.
 - Laser cutting apertures with trapezoidal walls and also rounding corners will offer better paste release. Customers should contact their board assembly site for stencil design recommendations. Refer to IPC-7525 for other stencil recommendations.
 - Customers should contact their board fabrication site for solder mask tolerances between and around signal pads.

IMPORTANT NOTICE

Texas Instruments Incorporated and its subsidiaries (TI) reserve the right to make corrections, enhancements, improvements and other changes to its semiconductor products and services per JESD46, latest issue, and to discontinue any product or service per JESD48, latest issue. Buyers should obtain the latest relevant information before placing orders and should verify that such information is current and complete. All semiconductor products (also referred to herein as "components") are sold subject to TI's terms and conditions of sale supplied at the time of order acknowledgment.

TI warrants performance of its components to the specifications applicable at the time of sale, in accordance with the warranty in TI's terms and conditions of sale of semiconductor products. Testing and other quality control techniques are used to the extent TI deems necessary to support this warranty. Except where mandated by applicable law, testing of all parameters of each component is not necessarily performed.

TI assumes no liability for applications assistance or the design of Buyers' products. Buyers are responsible for their products and applications using TI components. To minimize the risks associated with Buyers' products and applications, Buyers should provide adequate design and operating safeguards.

TI does not warrant or represent that any license, either express or implied, is granted under any patent right, copyright, mask work right, or other intellectual property right relating to any combination, machine, or process in which TI components or services are used. Information published by TI regarding third-party products or services does not constitute a license to use such products or services or a warranty or endorsement thereof. Use of such information may require a license from a third party under the patents or other intellectual property of the third party, or a license from TI under the patents or other intellectual property of TI.

Reproduction of significant portions of TI information in TI data books or data sheets is permissible only if reproduction is without alteration and is accompanied by all associated warranties, conditions, limitations, and notices. TI is not responsible or liable for such altered documentation. Information of third parties may be subject to additional restrictions.

Resale of TI components or services with statements different from or beyond the parameters stated by TI for that component or service voids all express and any implied warranties for the associated TI component or service and is an unfair and deceptive business practice. TI is not responsible or liable for any such statements.

Buyer acknowledges and agrees that it is solely responsible for compliance with all legal, regulatory and safety-related requirements concerning its products, and any use of TI components in its applications, notwithstanding any applications-related information or support that may be provided by TI. Buyer represents and agrees that it has all the necessary expertise to create and implement safeguards which anticipate dangerous consequences of failures, monitor failures and their consequences, lessen the likelihood of failures that might cause harm and take appropriate remedial actions. Buyer will fully indemnify TI and its representatives against any damages arising out of the use of any TI components in safety-critical applications.

In some cases, TI components may be promoted specifically to facilitate safety-related applications. With such components, TI's goal is to help enable customers to design and create their own end-product solutions that meet applicable functional safety standards and requirements. Nonetheless, such components are subject to these terms.

No TI components are authorized for use in FDA Class III (or similar life-critical medical equipment) unless authorized officers of the parties have executed a special agreement specifically governing such use.

Only those TI components which TI has specifically designated as military grade or "enhanced plastic" are designed and intended for use in military/aerospace applications or environments. Buyer acknowledges and agrees that any military or aerospace use of TI components which have **not** been so designated is solely at the Buyer's risk, and that Buyer is solely responsible for compliance with all legal and regulatory requirements in connection with such use.

TI has specifically designated certain components as meeting ISO/TS16949 requirements, mainly for automotive use. In any case of use of non-designated products, TI will not be responsible for any failure to meet ISO/TS16949.

Products

Audio	www.ti.com/audio
Amplifiers	amplifier.ti.com
Data Converters	dataconverter.ti.com
DLP® Products	www.dlp.com
DSP	dsp.ti.com
Clocks and Timers	www.ti.com/clocks
Interface	interface.ti.com
Logic	logic.ti.com
Power Mgmt	power.ti.com
Microcontrollers	microcontroller.ti.com
RFID	www.ti-rfid.com
OMAP Applications Processors	www.ti.com/omap
Wireless Connectivity	www.ti.com/wirelessconnectivity

Applications

Automotive and Transportation	www.ti.com/automotive
Communications and Telecom	www.ti.com/communications
Computers and Peripherals	www.ti.com/computers
Consumer Electronics	www.ti.com/consumer-apps
Energy and Lighting	www.ti.com/energy
Industrial	www.ti.com/industrial
Medical	www.ti.com/medical
Security	www.ti.com/security
Space, Avionics and Defense	www.ti.com/space-avionics-defense
Video and Imaging	www.ti.com/video

TI E2E Community

e2e.ti.com