

## TS12A4451x Low ON-State Resistance 4-Channel SPST CMOS Analog Switches

### 1 Features

- 2-V to 12-V Single-Supply Operation
- Specified ON-State Resistance:
  - 15-Ω Maximum With 12-V Supply
  - 20-Ω Maximum With 5-V Supply
  - 50-Ω Maximum With 3.3-V Supply
- $\Delta R_{ON}$  Matching
  - 2.5-Ω (Max) at 12 V
  - 3-Ω (Max) at 5 V
  - 3.5-Ω (Max) at 3.3 V
- Specified Low OFF-Leakage Currents:
  - 1 nA at 25°C
  - 10 nA at 85°C
- Specified Low ON-Leakage Currents:
  - 1 nA at 25°C
  - 10 nA at 85°C
- Low Charge Injection: 11.5 pC (12-V Supply)
- Fast Switching Speed:
  - $t_{ON} = 80$  ns,  $t_{OFF} = 50$  ns (12-V Supply)
- Break-Before-Make Operation ( $t_{ON} > t_{OFF}$ )
- TTL/CMOS-Logic Compatible With 5-V Supply
- Available in 14-Pin TSSOP Package or 14-Pin SOIC Package

### 2 Applications

- Data Acquisition Systems
- Communication Circuits
- Signal Routing
- Computer Peripherals

### 3 Description

The TS12A44513, TS12A44514, and TS12A44515 devices have four bidirectional single-pole single-throw (SPST) single-supply CMOS analog switches. The TS12A44513 has two normally closed (NC) switches and two normally open (NO) switches, the TS12A44514 has four NO switches, and the TS12A44515 has four NC switches.

These CMOS switches can operate continuously with a single supply from 2 V to 12 V and can handle rail-to-rail analog signals. The OFF-leakage current maximum is only 1 nA at 25°C or 10 nA at 85°C.

When using a 5-V supply, all digital inputs have 0.8-V to 2.4-V logic thresholds, ensuring TTL/CMOS-logic compatibility.

#### Device Information<sup>(1)</sup>

PART NUMBER	PACKAGE	BODY SIZE (NOM)
TS12A44513, TS12A44514, TS12A44515	TSSOP (14)	5.00 mm x 4.4 mm
	SOIC (14)	8.65 mm x 3.91 mm

(1) For all available packages, see the orderable addendum at the end of the datasheet.

#### Simplified Schematic

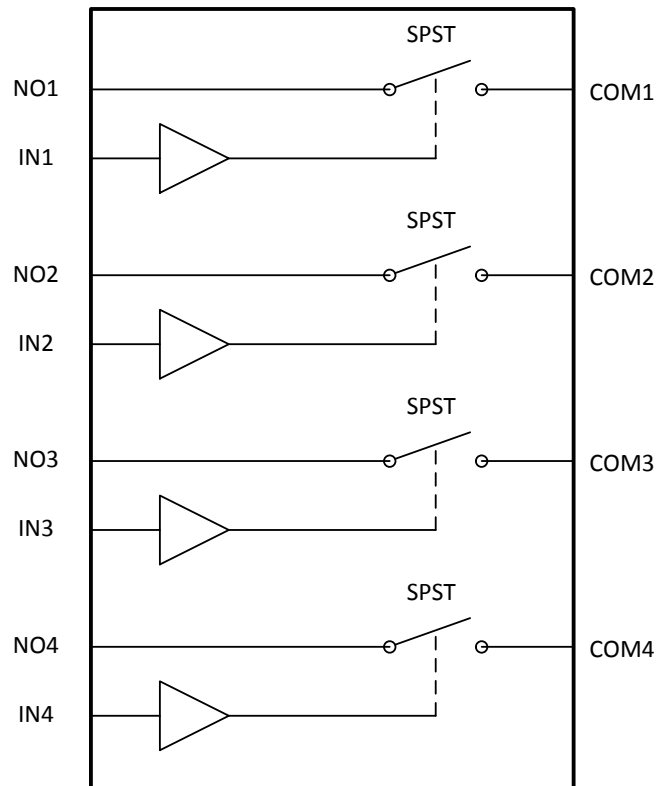

## Table of Contents

<b>1 Features</b> .....	<b>1</b>	7.2 Functional Block Diagram .....	<b>10</b>
<b>2 Applications</b> .....	<b>1</b>	7.3 Feature Description .....	<b>10</b>
<b>3 Description</b> .....	<b>1</b>	7.4 Device Functional Modes .....	<b>10</b>
<b>4 Revision History</b> .....	<b>2</b>	<b>8 Application and Implementation</b> .....	<b>11</b>
<b>5 Pin Configuration and Functions</b> .....	<b>3</b>	8.1 Application Information .....	<b>11</b>
<b>6 Specifications</b> .....	<b>4</b>	8.2 Typical Application .....	<b>12</b>
6.1 Absolute Maximum Ratings .....	<b>4</b>	<b>9 Power Supply Recommendations</b> .....	<b>13</b>
6.2 ESD Ratings .....	<b>4</b>	<b>10 Layout</b> .....	<b>14</b>
6.3 Recommended Operating Conditions .....	<b>4</b>	10.1 Layout Guidelines .....	<b>14</b>
6.4 Thermal Information .....	<b>4</b>	10.2 Layout Example .....	<b>14</b>
6.5 Electrical Characteristics for 5-V Supply .....	<b>5</b>	<b>11 Device and Documentation Support</b> .....	<b>15</b>
6.6 Electrical Characteristics for 12-V Supply .....	<b>6</b>	11.1 Related Links .....	<b>15</b>
6.7 Electrical Characteristics for 3-V Supply .....	<b>7</b>	11.2 Trademarks .....	<b>15</b>
6.8 Typical Characteristics .....	<b>9</b>	11.3 Electrostatic Discharge Caution .....	<b>15</b>
<b>7 Detailed Description</b> .....	<b>10</b>	11.4 Glossary .....	<b>15</b>
7.1 Overview .....	<b>10</b>	<b>12 Mechanical, Packaging, and Orderable Information</b> .....	<b>15</b>

## 4 Revision History

### Changes from Original (October 2008) to Revision A

**Page**

- Added *Pin Configuration and Functions* section, *ESD Ratings* table, *Feature Description* section, *Device Functional Modes*, *Application and Implementation* section, *Power Supply Recommendations* section, *Layout* section, *Device and Documentation Support* section, and *Mechanical, Packaging, and Orderable Information* section ..... **1**

## 5 Pin Configuration and Functions

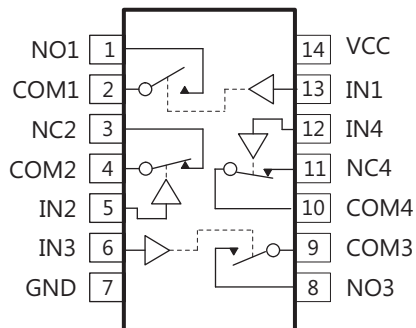
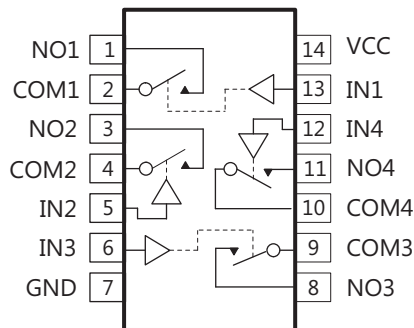
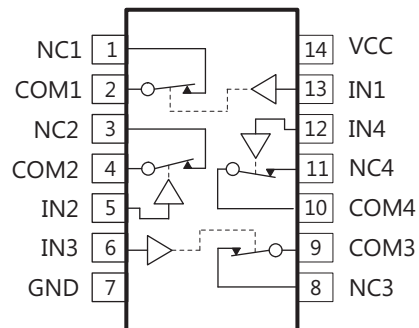
**D OR PW PACKAGE...TS12A44513  
(TOP VIEW)**

**D OR PW PACKAGE...TS12A44514  
(TOP VIEW)**

**D OR PW PACKAGE...TS12A44515  
(TOP VIEW)**

### Pin Functions

NAME	PIN			I/O	DESCRIPTION
	TS12A44513	TS12A44514	TS12A44515		
COM	2, 4, 9, 10	2, 4, 9, 10	2, 4, 9, 10	I/O	Common
VCC	14	14	14	I	Power supply
IN	5, 6, 12, 13	5, 6, 12, 13	5, 6, 12, 13	I	Digital control to connect COM to NO or NC
GND	7	7	7	GND	Ground
NO	1, 8	1, 3, 8, 11	–	I/O	Normally open
NC	3, 11	–	1, 3, 8, 11	I/O	Normally closed

## 6 Specifications

### 6.1 Absolute Maximum Ratings<sup>(1)(2)(3)</sup>

		MIN	MAX	UNIT
$V_{CC}$	Supply voltage	-0.3	13	V
$V_{NC}$ $V_{NO}$ $V_{COM}$	Analog voltage <sup>(4)</sup>	-0.3	$V_{CC} + 0.3$	V
$I_{NC}$ $I_{NO}$ $I_{COM}$ $I_{IN}$	Analog current	-20	20	mA
	Peak current (pulsed at 1 ms, 10% duty cycle)		±30	mA
$T_A$	Operating temperature	-40	85	°C
$P_D$	Power dissipation	Mounted on JEDEC 4-layer board (JESD 51-7), No airflow, $T_A = 25^\circ\text{C}$ , $T_J = 125^\circ\text{C}$ PW package		0.88 W
$T_{stg}$	Storage temperature	-65	150	°C

- (1) Stresses beyond those listed under *Absolute Maximum Ratings* may cause permanent damage to the device. These are stress ratings only, and functional operation of the device at these or any other conditions beyond those indicated under *Recommended Operating Conditions* is not implied. Exposure to absolute-maximum-rated conditions for extended periods may affect device reliability.
- (2) The algebraic convention, whereby the most negative value is a minimum and the most positive value is a maximum
- (3) Voltages referenced to GND
- (4) Voltages exceeding  $V_{CC}$  or GND on any signal terminal are clamped by internal diodes. Limit forward-diode current to maximum current rating.

### 6.2 ESD Ratings

		VALUE	UNIT
$V_{(ESD)}$	Electrostatic discharge	Human-body model (HBM), per ANSI/ESDA/JEDEC JS-001 <sup>(1)</sup>	V
		Charged-device model (CDM), per JEDEC specification JESD22-C101 <sup>(2)</sup>	
		±2000	
		±500	

- (1) JEDEC document JEP155 states that 500-V HBM allows safe manufacturing with a standard ESD control process.
- (2) JEDEC document JEP157 states that 250-V CDM allows safe manufacturing with a standard ESD control process.

### 6.3 Recommended Operating Conditions

over operating free-air temperature range (unless otherwise noted)

		MIN	MAX	UNIT
$V_{CC}$		0	12	V
$V_{NC}, V_{NO}, V_{COM}, V_{IN}$		0	$V_{CC}$	V

### 6.4 Thermal Information

THERMAL METRIC <sup>(1)</sup>	TS12A44513, TS12A44514, TS12A44515		UNIT	
	D	PW		
	14 PINS	14 PINS		
$R_{\theta JA}$	Junction-to-ambient thermal resistance	89.8	119.6	°C/W
$R_{\theta JC(top)}$	Junction-to-case (top) thermal resistance	49.6	48.4	
$R_{\theta JB}$	Junction-to-board thermal resistance	44.4	61.3	
$\Psi_{JT}$	Junction-to-top characterization parameter	13.8	5.7	
$\Psi_{JB}$	Junction-to-board characterization parameter	44.1	60.7	

- (1) For more information about traditional and new thermal metrics, see the *IC Package Thermal Metrics* application report, [SPRA953](#).

## 6.5 Electrical Characteristics for 5-V Supply<sup>(1)</sup>

 $V_{CC} = 4.5 \text{ V to } 5.5 \text{ V}$ ,  $V_{INH} = 2.4 \text{ V}$ ,  $V_{INL} = 0.8 \text{ V}$ ,  $T_A = -40^\circ\text{C to } 85^\circ\text{C}$  (unless otherwise noted)

PARAMETER	TEST CONDITIONS	$T_A$	MIN	TYP <sup>(2)</sup>	MAX	UNIT
<b>ANALOG SWITCH</b>						
$V_{COM}$ , $V_{NO}$ , $V_{NC}$	Analog signal range		0		$V_{CC}$	V
$R_{on}$	ON-state resistance	$V_{CC} = 4.5 \text{ V}$ , $V_{COM} = 3.5 \text{ V}$ , $I_{COM} = 1 \text{ mA}$	25°C	12	20	Ω
		Full			30	
$R_{on(Flat)}$	ON-state resistance flatness	$V_{COM} = 1 \text{ V}, 2 \text{ V}, 3 \text{ V}$ , $I_{COM} = 1 \text{ mA}$	25°C	1	3	Ω
		Full			4	
$\Delta R_{on}$	ON-state resistance matching between channels <sup>(3)</sup>	$V_{CC} = 4.5 \text{ V}$ , $I_{COM} = 5 \text{ mA}$ , $V_{NO}$ or $V_{NC} = 3 \text{ V}$	25°C		3	Ω
		$T_{MIN}$ to $T_{MAX}$			4	
$I_{NO(OFF)}$ , $I_{NC(OFF)}$	NO, NC OFF leakage current <sup>(4)</sup>	$V_{CC} = 5.5 \text{ V}$ , $V_{COM} = 1 \text{ V}$ , $V_{NO}$ or $V_{NC} = 4.5 \text{ V}$	25°C		1	nA
		Full			10	
$I_{COM(OFF)}$	COM OFF leakage current <sup>(4)</sup>	$V_{CC} = 5.5 \text{ V}$ , $V_{COM} = 1 \text{ V}$ , $V_{NO}$ or $V_{NC} = 4.5 \text{ V}$	25°C		1	nA
		Full			10	
$I_{COM(ON)}$	COM ON leakage current <sup>(4)</sup>	$V_{CC} = 5.5 \text{ V}$ , $V_{COM} = 4.5 \text{ V}$ , $V_{NO}$ or $V_{NC} = 4.5 \text{ V}$	25°C		1	nA
		Full			10	
<b>DIGITAL CONTROL INPUT (IN)</b>						
$V_{IH}$	Input logic high		Full	2.4	$V_{CC}$	V
$V_{IL}$	Input logic low		Full	0	0.8	V
$I_{IH}$ , $I_{IL}$	Input leakage current	$V_{IN} = V_{CC}, 0 \text{ V}$	Full		0.01	μA
<b>DYNAMIC</b>						
$t_{ON}$	Turn-on time	see <a href="#">Figure 2</a>	25°C	45	100	ns
			Full		125	
$t_{OFF}$	Turn-off time	see <a href="#">Figure 2</a>	25°C	35	50	ns
			Full		70	
$Q_C$	Charge injection <sup>(5)</sup>	$C_L = 1 \text{ nF}$ , $V_{NO} = 0 \text{ V}$ , $R_S = 0 \text{ } \Omega$ . See <a href="#">Figure 1</a>	25°C	-1.5		pC
$C_{NO(OFF)}$ , $C_{NC(OFF)}$	NO, NC OFF capacitance	$f = 1 \text{ MHz}$ . See <a href="#">Figure 4</a>	25°C	8		pF
$C_{COM(OFF)}$	COM OFF capacitance	$f = 1 \text{ MHz}$ . See <a href="#">Figure 4</a>	25°C	8		pF
$C_{COM(ON)}$	COM ON capacitance	$f = 1 \text{ MHz}$ . See <a href="#">Figure 4</a>	25°C	19		pF
$C_I$	Digital input capacitance	$V_{IN} = V_{CC}, 0 \text{ V}$	25°C	2		pF
BW	Bandwidth	$R_L = 50 \text{ } \Omega$ , $C_L = 15 \text{ pF}$ , $V_{NO} = 1 \text{ V}_{RMS}$ .	25°C	530		MHz
$O_{ISO}$	OFF isolation	$R_L = 50 \text{ } \Omega$ , $C_L = 15 \text{ pF}$ , $V_{NO} = 1 \text{ V}_{RMS}$ . $f = 100 \text{ kHz}$	25°C	-94		dB
THD	Total harmonic distortion	$R_L = 50 \text{ } \Omega$ , $C_L = 15 \text{ pF}$ , $V_{NO} = 1 \text{ V}_{RMS}$ . $f = 100 \text{ kHz}$	25°C	0.09%		

- (1) The algebraic convention, whereby the most negative value is a minimum and the most positive value is a maximum.
- (2) Typical values are at  $T_A = 25^\circ\text{C}$ .
- (3)  $\Delta R_{ON} = R_{ON(MAX)} - R_{ON(MIN)}$
- (4) Leakage parameters are 100% tested at maximum-rated hot operating temperature, and are ensured by correlation at  $25^\circ\text{C}$ .
- (5) Specified by design, not production tested

## 6.6 Electrical Characteristics for 12-V Supply<sup>(1)</sup>

 $V_{CC} = 11.4\text{ V to }12.6\text{ V}$ ,  $V_{INH} = 5\text{ V}$ ,  $V_{INL} = 0.8\text{ V}$ ,  $T_A = -40^\circ\text{C to }85^\circ\text{C}$  (unless otherwise noted)

PARAMETER	TEST CONDITIONS	$T_A$	MIN	TYP <sup>(2)</sup>	MAX	UNIT
<b>ANALOG SWITCH</b>						
$V_{COM}$ , $V_{NO}$ , $V_{NC}$	Analog signal range		0		$V_{CC}$	V
$R_{on}$	ON-state resistance	$V_{CC} = 11.4\text{ V}$ , $V_{COM} = 10\text{ V}$ , $I_{COM} = 1\text{ mA}$	25°C	6.5	10	Ω
		Full			15	
$R_{on(Flat)}$	ON-state resistance flatness	$V_{CC} = 11.4\text{ V}$ , $V_{COM} = 2\text{ V}, 5\text{ V}, 10\text{ V}$ , $I_{COM} = 1\text{ mA}$	25°C	1.5	3	Ω
		Full			4	
$\Delta R_{on}$	ON-state resistance matching between channels <sup>(3)</sup>	$V_{CC} = 11.4\text{ V}$ , $I_{COM} = 5\text{ mA}$ , $V_{NO}$ or $V_{NC} = 10\text{ V}$	25°C		2.5	Ω
		$T_{MIN}$ to $T_{MAX}$			3	
$I_{NO(OFF)}$ , $I_{NC(OFF)}$	NO, NC OFF leakage current <sup>(4)</sup>	$V_{CC} = 12.6\text{ V}$ , $V_{COM} = 1\text{ V}$ , $V_{NO}$ or $V_{NC} = 10\text{ V}$	25°C		1	nA
		Full			10	
$I_{COM(OFF)}$	COM OFF leakage current <sup>(4)</sup>	$V_{CC} = 12.6\text{ V}$ , $V_{COM} = 1\text{ V}$ , $V_{NO}$ or $V_{NC} = 10\text{ V}$	25°C		1	nA
		Full			10	
$I_{COM(ON)}$	COM ON leakage current <sup>(4)</sup>	$V_{CC} = 12.6\text{ V}$ , $V_{COM} = 10\text{ V}$ , $V_{NO}$ or $V_{NC} = 10\text{ V}$	25°C		1	nA
		Full			10	
<b>DIGITAL CONTROL INPUT (IN)</b>						
$V_{IH}$	Input logic high		Full	5	$V_{CC}$	V
$V_{IL}$	Input logic low		Full	0	0.8	V
$I_{IH}$ , $I_{IL}$	Input leakage current	$V_{IN} = V_{CC}, 0\text{ V}$	Full		0.001	μA
<b>DYNAMIC</b>						
$t_{ON}$	Turn-on time	See <a href="#">Figure 2</a>	25°C	25	75	ns
			Full		80	
$t_{OFF}$	Turn-off time	See <a href="#">Figure 2</a>	25°C	20	45	ns
			Full		50	
$Q_C$	Charge injection <sup>(5)</sup>	$C_L = 1\text{ nF}$ , $V_{NO} = 0\text{ V}$ , $R_S = 0\text{ }\Omega$ , See <a href="#">Figure 1</a>	25°C	-10.5		pC
$C_{NO(OFF)}$ , $C_{NC(OFF)}$	NO, NC OFF capacitance	$f = 1\text{ MHz}$ , See <a href="#">Figure 4</a>	25°C	8		pF
$C_{COM(OFF)}$	COM OFF capacitance	$f = 1\text{ MHz}$ , See <a href="#">Figure 4</a>	25°C	8		pF
$C_{COM(ON)}$	COM ON capacitance	$f = 1\text{ MHz}$ , See <a href="#">Figure 4</a>	25°C	21.5		pF
$C_I$	Digital input capacitance	$V_{IN} = V_{CC}, 0\text{ V}$	25°C	2		pF
BW	Bandwidth	$R_L = 50\text{ }\Omega$ , $C_L = 15\text{ pF}$ , $V_{NO} = 1\text{ V}_{RMS}$	25°C	530		MHz
$O_{ISO}$	OFF isolation	$R_L = 50\text{ }\Omega$ , $C_L = 15\text{ pF}$ , $V_{NO} = 1\text{ V}_{RMS}$ , $f = 100\text{ kHz}$	25°C	-95		dB
THD	Total harmonic distortion	$R_L = 50\text{ }\Omega$ , $C_L = 15\text{ pF}$ , $V_{NO} = 1\text{ V}_{RMS}$ , $f = 100\text{ kHz}$	25°C	0.07%		

(1) The algebraic convention, whereby the most negative value is a minimum and the most positive value is a maximum.

(2) Typical Values are at  $T_A = 25^\circ\text{C}$ .

(3)  $\Delta R_{ON} = R_{ON(MAX)} - R_{ON(MIN)}$

(4) Leakage parameters are 100% tested at maximum-rated hot operating temperature, and are ensured by correlation at 25°C.

(5) Specified by design, not production tested

## 6.7 Electrical Characteristics for 3-V Supply<sup>(1)</sup>

 $V_{CC} = 3\text{ V to }3.6\text{ V}$ ,  $T_A = -40^\circ\text{C to }85^\circ\text{C}$  (unless otherwise noted)

PARAMETER	TEST CONDITIONS	$T_A$	MIN	TYP <sup>(2)</sup>	MAX	UNIT
<b>ANALOG SWITCH</b>						
$V_{COM}, V_{NO}, V_{NC}$	Analog signal range		0		$V_{CC}$	V
$R_{on}$	ON-state resistance	$V_{CC} = 3\text{ V}, V_{COM} = 1.5\text{ V}, I_{NO} = 1\text{ mA}$	25°C	20	40	Ω
		Full			50	
$R_{on(Flat)}$	ON-state resistance flatness	$V_{CC} = 3\text{ V}, V_{COM} = 1\text{ V}, 1.5\text{ V}, 2\text{ V}, I_{COM} = 1\text{ mA}$	25°C	1	3	Ω
		Full			4	
$\Delta R_{on}$	ON-state resistance matching between channels <sup>(3)</sup>	$V_{CC} = 2.7\text{ V}, I_{COM} = 5\text{ mA}, V_{NO}\text{ or }V_{NC} = 1.5\text{ V}$	25°C		3.5	Ω
		$T_{MIN}\text{ to }T_{MAX}$			4.5	
$I_{NO(OFF)}, I_{NC(OFF)}$	NO, NC OFF leakage current <sup>(4)</sup>	$V_{CC} = 3.6\text{ V}, V_{COM} = 1\text{ V}, V_{NO}\text{ or }V_{NC} = 3\text{ V}$	25°C		1	nA
		Full			10	
$I_{COM(OFF)}$	COM OFF leakage current <sup>(4)</sup>	$V_{CC} = 3.6\text{ V}, V_{COM} = 1\text{ V}, V_{NO}\text{ or }V_{NC} = 3\text{ V}$	25°C		1	nA
		Full			10	
$I_{COM(ON)}$	COM ON leakage current <sup>(4)</sup>	$V_{CC} = 3.6\text{ V}, V_{COM} = 3\text{ V}, V_{NO}\text{ or }V_{NC} = 3\text{ V}$	25°C		1	nA
		Full			10	
<b>DIGITAL CONTROL INPUT (IN)</b>						
$V_{IH}$	Input logic high		Full	2.4	$V_{CC}$	V
$V_{IL}$	Input logic low		Full	0	0.8	V
$I_{IH}, I_{IL}$	Input leakage current	$V_{IN} = V_{CC}, 0\text{ V}$	Full		0.01	μA
<b>DYNAMIC</b>						
$t_{ON}$	Turn-on time <sup>(5)</sup>	See <a href="#">Figure 2</a>	25°C	70	120	ns
			Full		175	
$t_{OFF}$	Turn-off time <sup>(5)</sup>	See <a href="#">Figure 2</a>	25°C	50	80	ns
			Full		120	
$Q_C$	Charge injection <sup>(5)</sup>	$C_L = 1\text{ nF}$ , See <a href="#">Figure 1</a>	25°C	-0.5		pC
$C_{NO(OFF)}, C_{NC(OFF)}$	NO, NC OFF capacitance	$f = 1\text{ MHz}$ , See <a href="#">Figure 4</a>	25°C	8		pF
$C_{COM(OFF)}$	COM OFF capacitance	$f = 1\text{ MHz}$ , See <a href="#">Figure 4</a>	25°C	8		pF
$C_{COM(ON)}$	COM ON capacitance	$f = 1\text{ MHz}$ , See <a href="#">Figure 4</a>	25°C	17		pF
$C_I$	Digital input capacitance	$V_{IN} = V_{CC}, 0\text{ V}$	25°C	2		pF
BW	Bandwidth	$R_L = 50\ \Omega, C_L = 15\text{ pF}, V_{NO} = 1\text{ V}_{RMS}, f = 100\text{ kHz}$	25°C	510		MHz
$O_{ISO}$	OFF isolation	$R_L = 50\ \Omega, C_L = 15\text{ pF}, V_{NO} = 1\text{ V}_{RMS}, f = 100\text{ kHz}$	25°C	-94		dB
THD	Total harmonic distortion	$R_L = 50\ \Omega, C_L = 15\text{ pF}, V_{NO} = 1\text{ V}_{RMS}, f = 100\text{ kHz}$	25°C	0.27%		

(1) The algebraic convention, whereby the most negative value is a minimum and the most positive value is a maximum.

(2) Typical values are at  $T_A = 25^\circ\text{C}$ .

(3)  $\Delta R_{ON} = R_{ON(MAX)} - R_{ON(MIN)}$

(4) Leakage parameters are 100% tested at maximum-rated hot operating temperature, and are ensured by correlation at  $25^\circ\text{C}$ .

(5) Specified by design, not production tested

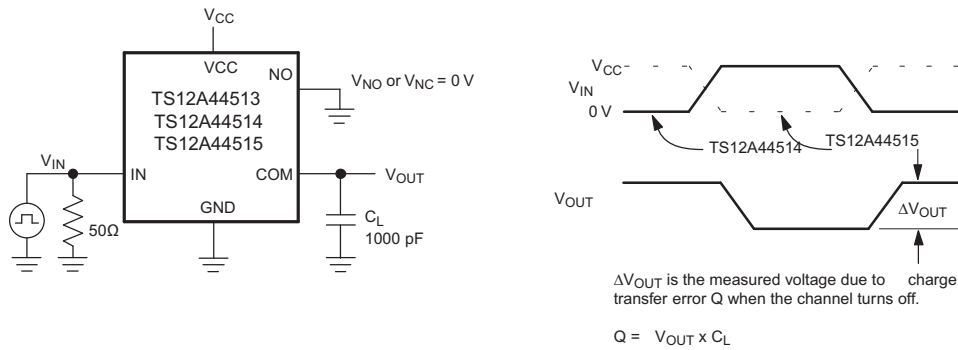

Figure 1. Charge Injection

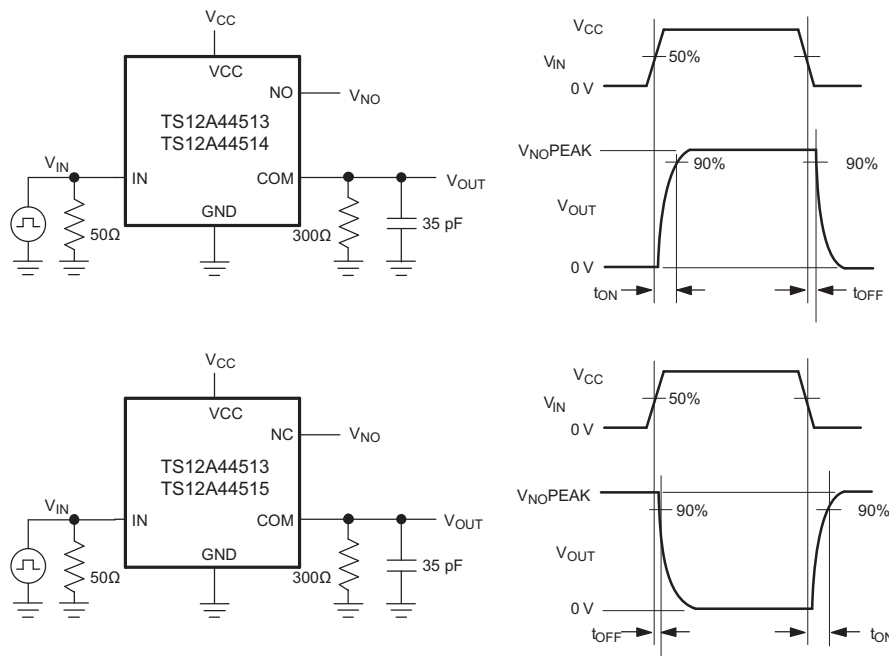
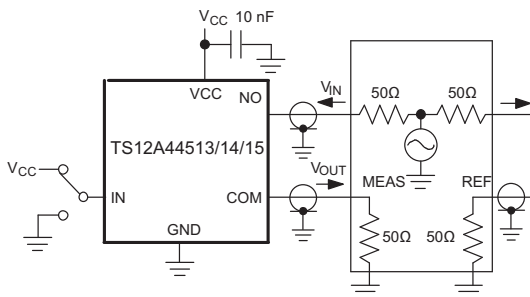

Figure 2. Switching Times



Measurements are standardized against short at socket terminals. OFF isolation is measured between COM and OFF terminals on each switch. ON loss is measured between COM and ON terminals on each switch. Signal direction through switch is reversed; worst values are recorded.

$$\text{OFF Isolation} = 20 \log \frac{V_{OUT}}{V_{IN}}$$

$$\text{ON Loss} = 20 \log \frac{V_{OUT}}{V_{IN}}$$

Figure 3. Off Isolation and On Loss

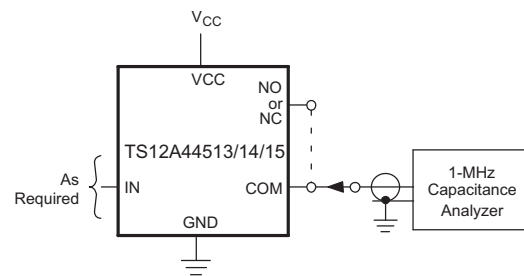

Figure 4. NO, NC, and COM Capacitance

6.8 Typical Characteristics

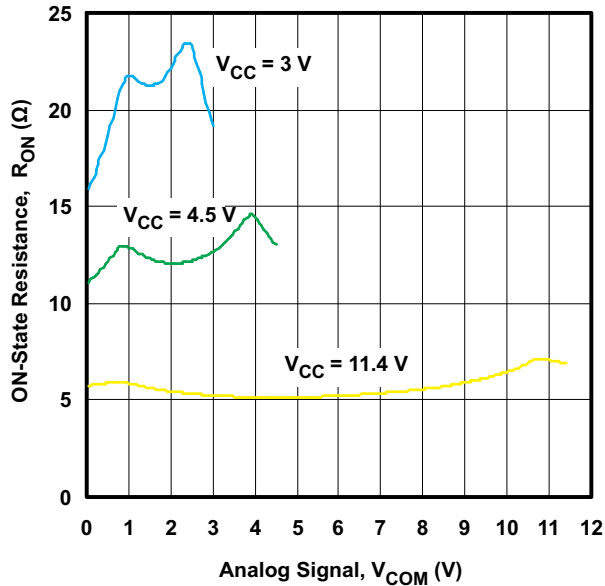

Figure 5.  $R_{ON}$  vs  $V_{COM}$  ( $T_A = 25^\circ C$ )

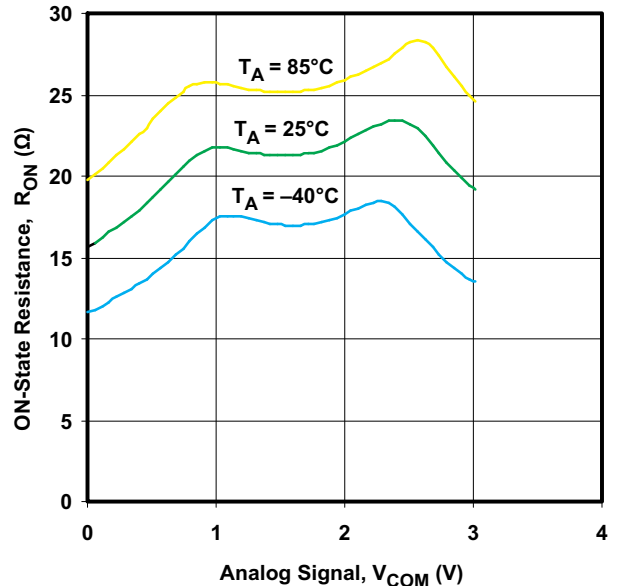

Figure 6.  $R_{ON}$  vs  $V_{COM}$  ( $V_{CC} = 3V$ )

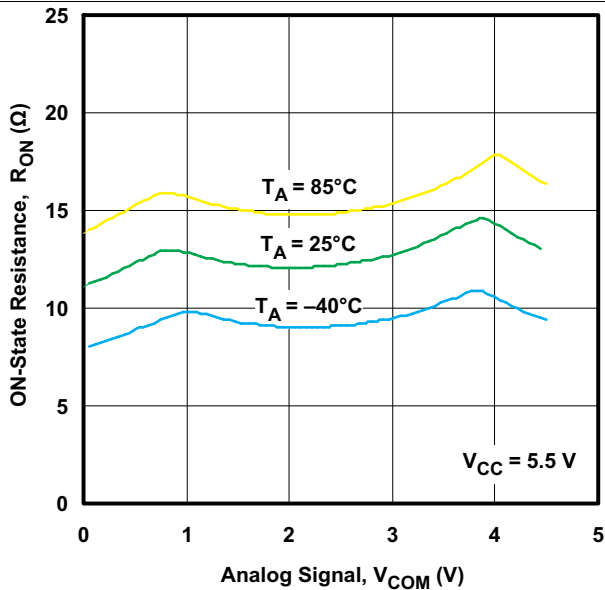

Figure 7.  $R_{ON}$  vs  $V_{COM}$  ( $V_{CC} = 4.5V$ )

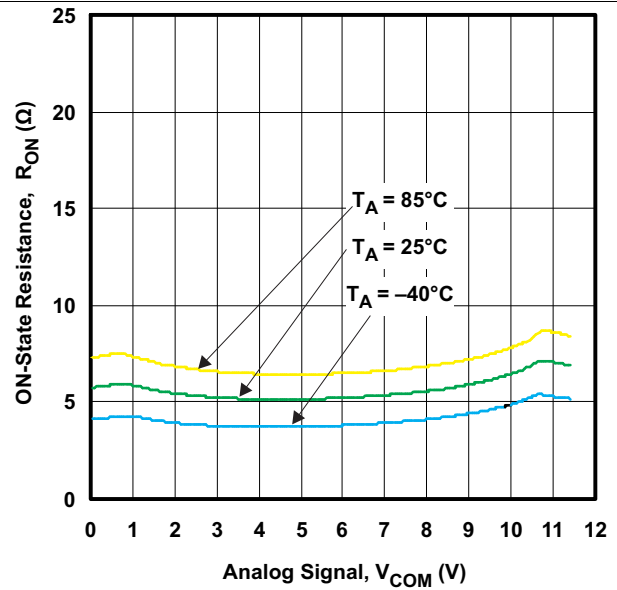

Figure 8.  $R_{ON}$  vs  $V_{COM}$  ( $V_{CC} = 11.4V$ )

## 7 Detailed Description

### 7.1 Overview

The TS12A4451x has 4 bidirectional single-pole single-throw (SPST) single-supply CMOS analog switches. The TS12A44513 has two normally closed (NC) switches and two normally open (NO) switches, the TS12A44514 has four normally open (NO) switches, and the TS12A44515 has four normally closed (NC) switches.

These CMOS switches can operate continuously with a single supply between 2 V and 12 V and can handle rail-to-rail analog signals. The OFF-leakage current maximum is only 1 nA at 25°C or 10 nA at 85°C.

When using a 5-V supply, all digital inputs have 0.8-V to 2.4-V logic thresholds, ensuring TTL/CMOS-logic compatibility.

### 7.2 Functional Block Diagram

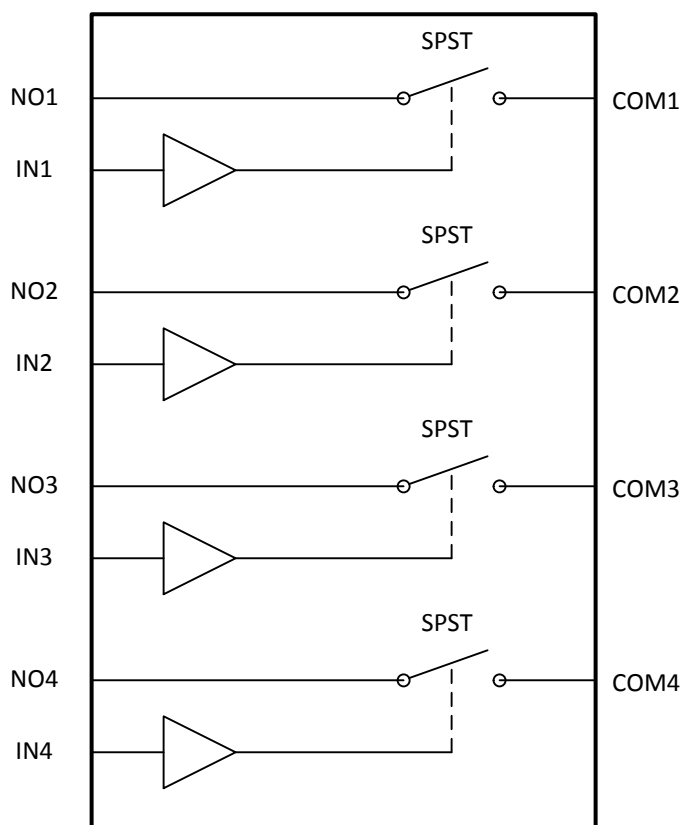

### 7.3 Feature Description

The TS12A4451x is bidirectional with fast switching times in the 10's of ns range which allows data acquisition and communication between multiple devices.

With a 5-V supply these devices are compatible with standard 1.8-V TTL/CMOS logic.

### 7.4 Device Functional Modes

**Table 1. Function Table**

IN	NO TO COM, COM TO NO	NC TO COM, COM TO NC
L	OFF	ON
H	ON	OFF

## 8 Application and Implementation

### NOTE

Information in the following applications sections is not part of the TI component specification, and TI does not warrant its accuracy or completeness. TI's customers are responsible for determining suitability of components for their purposes. Customers should validate and test their design implementation to confirm system functionality.

### 8.1 Application Information

The switches are bidirectional, so the NO, NC, and COM pins can be used as either inputs or outputs.

#### 8.1.1 Logic-Level Thresholds

The logic-level thresholds are CMOS/TTL compatible when  $V_{CC}$  is 5 V. As  $V_{CC}$  is raised, the level threshold increases slightly. When  $V_{CC}$  reaches 12 V, the level threshold is about 3 V – above the TTL-specified high-level minimum of 2.8 V, but still compatible with CMOS outputs.

### CAUTION

Do not connect the TS12A44513/TS12A44514/MAS4515  $V_{CC}$  to 3 V and then connect the logic-level pins to logic-level signals that operate from 5-V supply. Output levels can exceed 3 V and violate the absolute maximum ratings, damaging the part and/or external circuits.

## 8.2 Typical Application

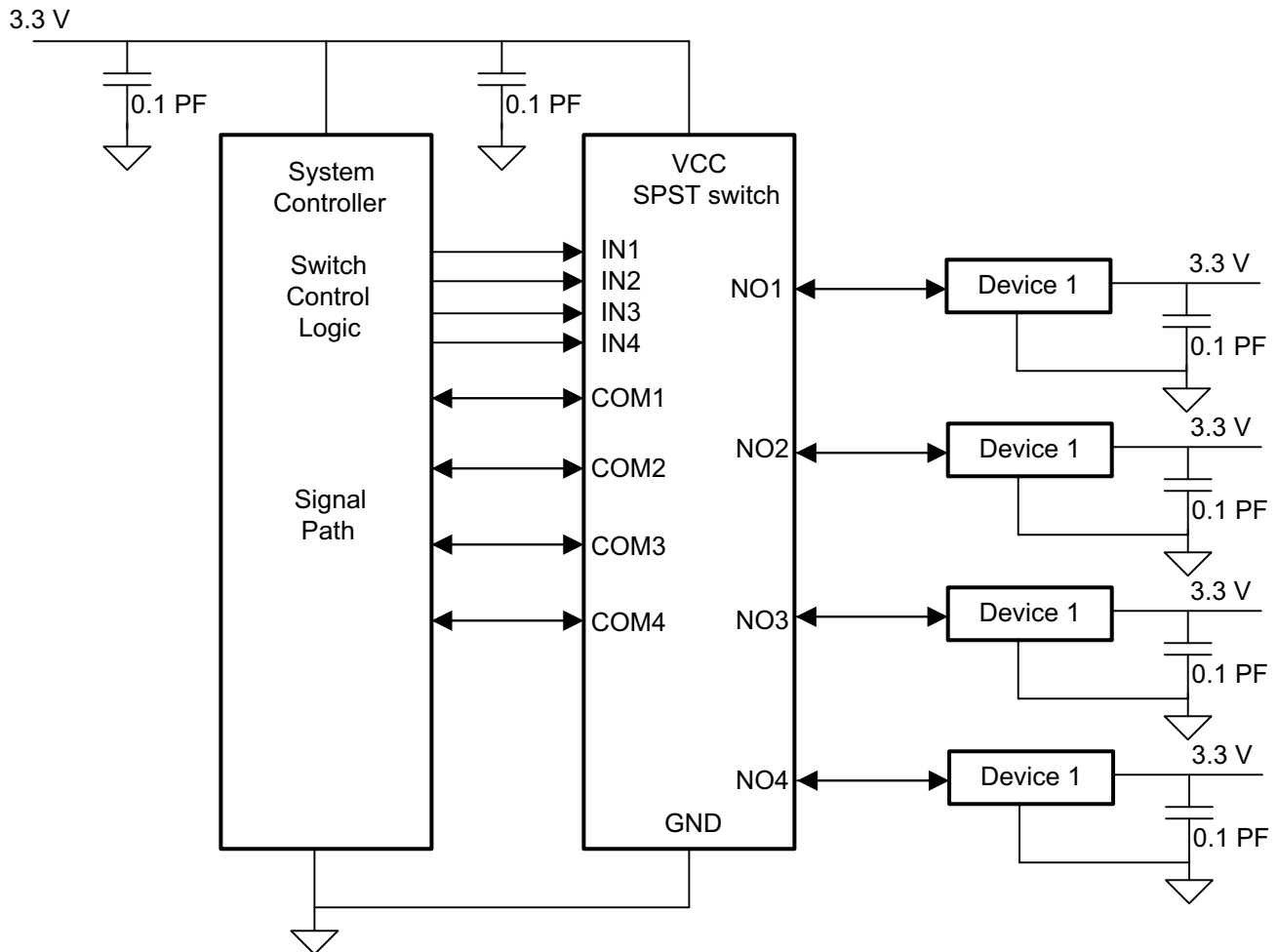

**Figure 9. Typical Application Schematic**

### 8.2.1 Design Requirements

Ensure that all of the signals passing through the switch are within the specified ranges to ensure proper performance.

**Table 2. Design Parameters**

	MIN	MAX	UNIT
$V_{CC}$	0	12	V
$V_{NC}, V_{NO}, V_{COM}, V_{IN}$	0	$V_{CC}$	V

### 8.2.2 Detailed Design Procedure

The TS12A4451x can be properly operated without any external components. However, it is recommended that unused pins should be connected to ground through a 50-Ω resistor to prevent signal reflections back into the device. It is also recommended that the digital control pins (INX) be pulled up to  $V_{CC}$  or down to GND to avoid undesired switch positions that could result from the floating pin.

### 8.2.3 Application Curve

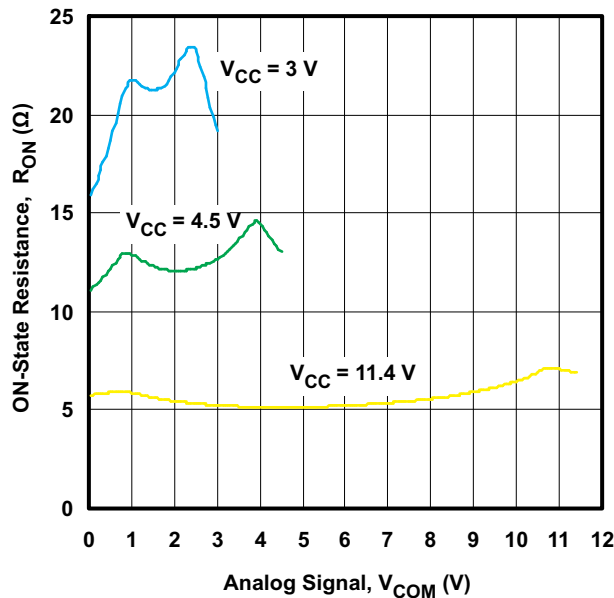

Figure 10. ON-State Resistance,  $R_{ON}$  vs Analog Signal,  $V_{COM}$

## 9 Power Supply Recommendations

The TS12A4451x construction is typical of most CMOS analog switches, except that they have only two supply pins: VCC and GND. VCC and GND drive the internal CMOS switches and set their analog voltage limits. Reverse ESD-protection diodes connected in series are internally connected between each analog-signal pin and both VCC and GND. If an analog signal exceeds  $V_{CC}$  or GND, one of the diodes will be forward biased, but the other will be reverse biased preventing current flow.

Virtually all the analog leakage current comes from the ESD diodes to VCC or GND. Although the ESD diodes on a given signal pin are identical and, therefore, fairly well balanced, they are reverse biased differently. Each is biased by either  $V_{CC}$  or GND and the analog signal. This means their leakages will vary as the signal varies. The difference in the two diode leakages to the VCC and GND pins constitutes the analog-signal-path leakage current. All analog leakage current flows between each pin and one of the supply terminals, not to the other switch terminal. This is why both sides of a given switch can show leakage currents of the same or opposite polarity.

There is no direct connection between the analog-signal paths and VCC or GND.

VCC and GND also power the internal logic and logic-level translators. The logic-level translators convert the logic levels to switched  $V_{CC}$  and GND signals to drive the analog signal gates.

## 10 Layout

### 10.1 Layout Guidelines

High-speed switches require proper layout and design procedures for optimum performance. Reduce stray inductance and capacitance by keeping traces short and wide. Ensure that bypass capacitors are as close to the device as possible. Use large ground planes where possible.

### 10.2 Layout Example

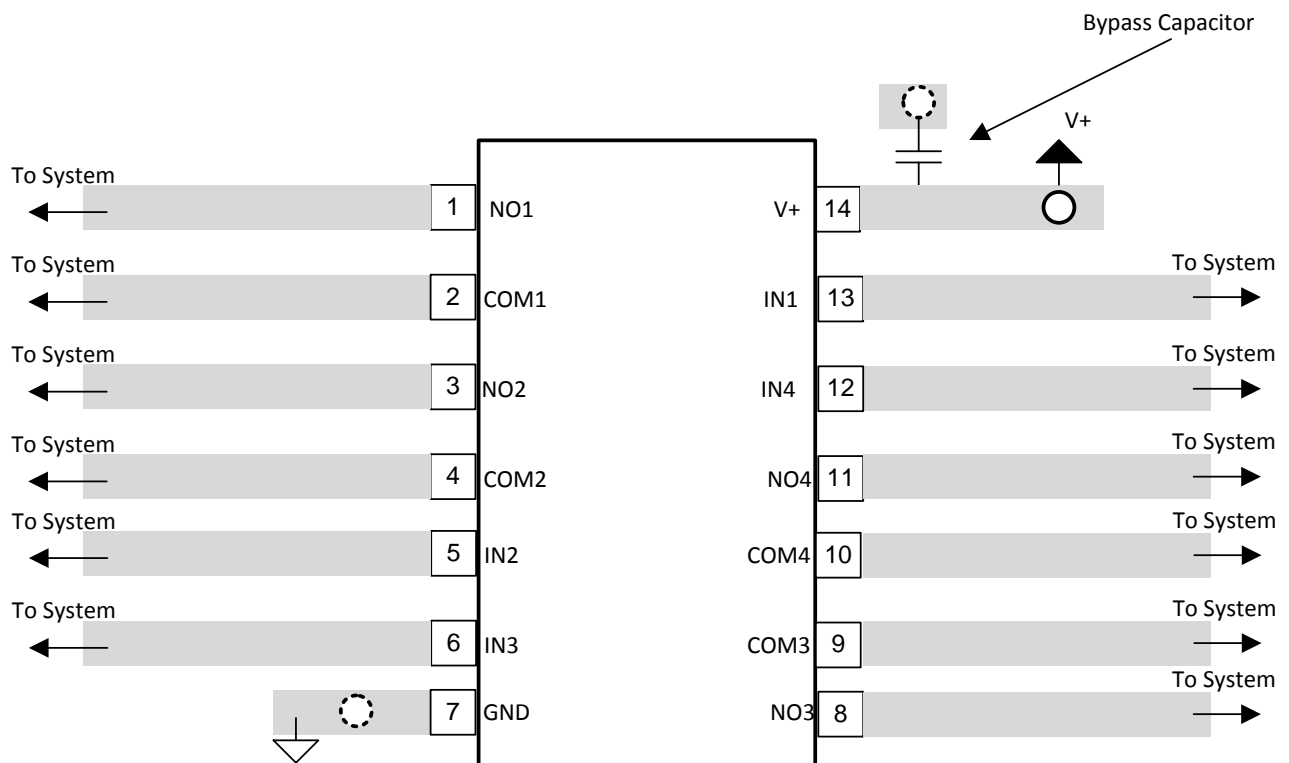
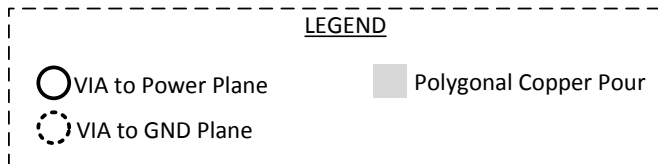

**Figure 11. Layout Schematic**

## 11 Device and Documentation Support

### 11.1 Related Links

The table below lists quick access links. Categories include technical documents, support and community resources, tools and software, and quick access to sample or buy.

**Table 3. Related Links**

PARTS	PRODUCT FOLDER	SAMPLE & BUY	TECHNICAL DOCUMENTS	TOOLS & SOFTWARE	SUPPORT & COMMUNITY
TS12A44513	<a href="#">Click here</a>	<a href="#">Click here</a>	<a href="#">Click here</a>	<a href="#">Click here</a>	<a href="#">Click here</a>
TS12A44514	<a href="#">Click here</a>	<a href="#">Click here</a>	<a href="#">Click here</a>	<a href="#">Click here</a>	<a href="#">Click here</a>
TS12A44515	<a href="#">Click here</a>	<a href="#">Click here</a>	<a href="#">Click here</a>	<a href="#">Click here</a>	<a href="#">Click here</a>

### 11.2 Trademarks

All trademarks are the property of their respective owners.

### 11.3 Electrostatic Discharge Caution



These devices have limited built-in ESD protection. The leads should be shorted together or the device placed in conductive foam during storage or handling to prevent electrostatic damage to the MOS gates.

### 11.4 Glossary

[SLYZ022](#) — *TI Glossary*.

This glossary lists and explains terms, acronyms, and definitions.

## 12 Mechanical, Packaging, and Orderable Information

The following pages include mechanical, packaging, and orderable information. This information is the most current data available for the designated devices. This data is subject to change without notice and revision of this document. For browser-based versions of this data sheet, refer to the left-hand navigation.

**PACKAGING INFORMATION**

Orderable Device	Status (1)	Package Type	Package Drawing	Pins	Package Qty	Eco Plan (2)	Lead/Ball Finish (6)	MSL Peak Temp (3)	Op Temp (°C)	Device Marking (4/5)	Samples
TS12A44513DR	ACTIVE	SOIC	D	14	2500	Green (RoHS & no Sb/Br)	CU NIPDAU	Level-1-260C-UNLIM	-40 to 85	TS12A44513	<a href="#">Samples</a>
TS12A44513PWR	ACTIVE	TSSOP	PW	14	2000	Green (RoHS & no Sb/Br)	CU NIPDAU	Level-1-260C-UNLIM	-40 to 85	YD4513	<a href="#">Samples</a>
TS12A44513PWRG4	ACTIVE	TSSOP	PW	14	2000	Green (RoHS & no Sb/Br)	CU NIPDAU	Level-1-260C-UNLIM	-40 to 85	YD4513	<a href="#">Samples</a>
TS12A44514DR	ACTIVE	SOIC	D	14	2500	Green (RoHS & no Sb/Br)	CU NIPDAU	Level-1-260C-UNLIM	-40 to 85	TS12A44514	<a href="#">Samples</a>
TS12A44514DRG4	ACTIVE	SOIC	D	14	2500	Green (RoHS & no Sb/Br)	CU NIPDAU	Level-1-260C-UNLIM	-40 to 85	TS12A44514	<a href="#">Samples</a>
TS12A44514PWR	ACTIVE	TSSOP	PW	14	2000	Green (RoHS & no Sb/Br)	CU NIPDAU	Level-1-260C-UNLIM	-40 to 85	YD4514	<a href="#">Samples</a>
TS12A44514PWRG4	ACTIVE	TSSOP	PW	14	2000	Green (RoHS & no Sb/Br)	CU NIPDAU	Level-1-260C-UNLIM	-40 to 85	YD4514	<a href="#">Samples</a>
TS12A44515DR	ACTIVE	SOIC	D	14	2500	Green (RoHS & no Sb/Br)	CU NIPDAU	Level-1-260C-UNLIM	-40 to 85	TS12A44515	<a href="#">Samples</a>
TS12A44515PWR	ACTIVE	TSSOP	PW	14	2000	Green (RoHS & no Sb/Br)	CU NIPDAU	Level-1-260C-UNLIM	-40 to 85	YD4515	<a href="#">Samples</a>

(1) The marketing status values are defined as follows:

**ACTIVE:** Product device recommended for new designs.

**LIFEBUY:** TI has announced that the device will be discontinued, and a lifetime-buy period is in effect.

**NRND:** Not recommended for new designs. Device is in production to support existing customers, but TI does not recommend using this part in a new design.

**PREVIEW:** Device has been announced but is not in production. Samples may or may not be available.

**OBSOLETE:** TI has discontinued the production of the device.

(2) Eco Plan - The planned eco-friendly classification: Pb-Free (RoHS), Pb-Free (RoHS Exempt), or Green (RoHS & no Sb/Br) - please check <http://www.ti.com/productcontent> for the latest availability information and additional product content details.

**TBD:** The Pb-Free/Green conversion plan has not been defined.

**Pb-Free (RoHS):** TI's terms "Lead-Free" or "Pb-Free" mean semiconductor products that are compatible with the current RoHS requirements for all 6 substances, including the requirement that lead not exceed 0.1% by weight in homogeneous materials. Where designed to be soldered at high temperatures, TI Pb-Free products are suitable for use in specified lead-free processes.

**Pb-Free (RoHS Exempt):** This component has a RoHS exemption for either 1) lead-based flip-chip solder bumps used between the die and package, or 2) lead-based die adhesive used between the die and leadframe. The component is otherwise considered Pb-Free (RoHS compatible) as defined above.

**Green (RoHS & no Sb/Br):** TI defines "Green" to mean Pb-Free (RoHS compatible), and free of Bromine (Br) and Antimony (Sb) based flame retardants (Br or Sb do not exceed 0.1% by weight in homogeneous material)

- (3) MSL, Peak Temp. - The Moisture Sensitivity Level rating according to the JEDEC industry standard classifications, and peak solder temperature.
- (4) There may be additional marking, which relates to the logo, the lot trace code information, or the environmental category on the device.
- (5) Multiple Device Markings will be inside parentheses. Only one Device Marking contained in parentheses and separated by a "~" will appear on a device. If a line is indented then it is a continuation of the previous line and the two combined represent the entire Device Marking for that device.
- (6) Lead/Ball Finish - Orderable Devices may have multiple material finish options. Finish options are separated by a vertical ruled line. Lead/Ball Finish values may wrap to two lines if the finish value exceeds the maximum column width.

**Important Information and Disclaimer:**The information provided on this page represents TI's knowledge and belief as of the date that it is provided. TI bases its knowledge and belief on information provided by third parties, and makes no representation or warranty as to the accuracy of such information. Efforts are underway to better integrate information from third parties. TI has taken and continues to take reasonable steps to provide representative and accurate information but may not have conducted destructive testing or chemical analysis on incoming materials and chemicals. TI and TI suppliers consider certain information to be proprietary, and thus CAS numbers and other limited information may not be available for release.

In no event shall TI's liability arising out of such information exceed the total purchase price of the TI part(s) at issue in this document sold by TI to Customer on an annual basis.

**TAPE AND REEL INFORMATION**

**QUADRANT ASSIGNMENTS FOR PIN 1 ORIENTATION IN TAPE**

\*All dimensions are nominal

Device	Package Type	Package Drawing	Pins	SPQ	Reel Diameter (mm)	Reel Width W1 (mm)	A0 (mm)	B0 (mm)	K0 (mm)	P1 (mm)	W (mm)	Pin1 Quadrant
TS12A44513DR	SOIC	D	14	2500	330.0	16.4	6.5	9.0	2.1	8.0	16.0	Q1
TS12A44513PWR	TSSOP	PW	14	2000	330.0	12.4	6.9	5.6	1.6	8.0	12.0	Q1
TS12A44514DR	SOIC	D	14	2500	330.0	16.4	6.5	9.0	2.1	8.0	16.0	Q1
TS12A44514PWR	TSSOP	PW	14	2000	330.0	12.4	6.9	5.6	1.6	8.0	12.0	Q1
TS12A44515DR	SOIC	D	14	2500	330.0	16.4	6.5	9.0	2.1	8.0	16.0	Q1
TS12A44515PWR	TSSOP	PW	14	2000	330.0	12.4	6.9	5.6	1.6	8.0	12.0	Q1

**TAPE AND REEL BOX DIMENSIONS**



\*All dimensions are nominal

Device	Package Type	Package Drawing	Pins	SPQ	Length (mm)	Width (mm)	Height (mm)
TS12A44513DR	SOIC	D	14	2500	367.0	367.0	38.0
TS12A44513PWR	TSSOP	PW	14	2000	367.0	367.0	35.0
TS12A44514DR	SOIC	D	14	2500	367.0	367.0	38.0
TS12A44514PWR	TSSOP	PW	14	2000	367.0	367.0	35.0
TS12A44515DR	SOIC	D	14	2500	367.0	367.0	38.0
TS12A44515PWR	TSSOP	PW	14	2000	367.0	367.0	35.0

D (R-PDSO-G14)

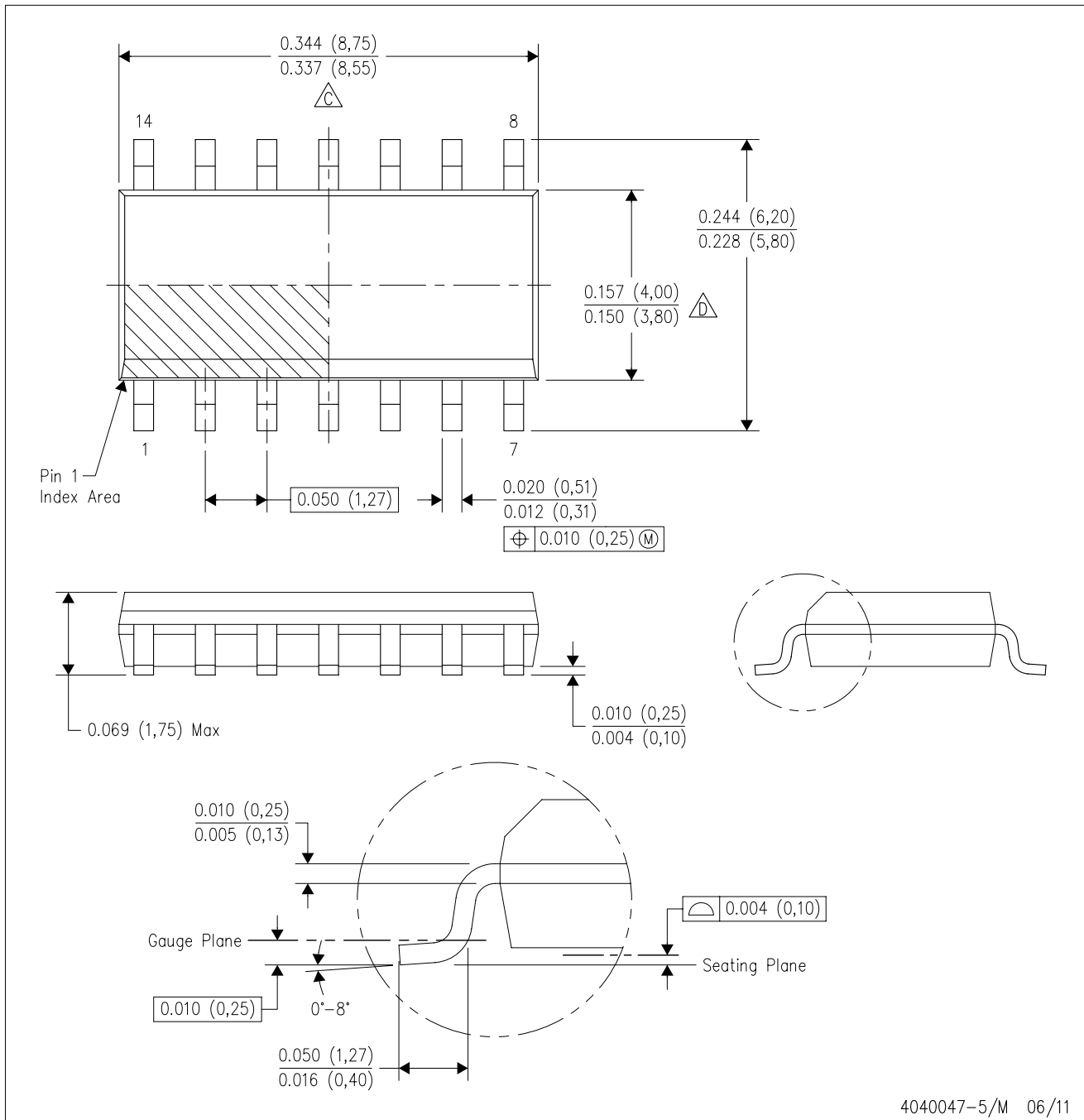
PLASTIC SMALL OUTLINE



- NOTES:
- A. All linear dimensions are in inches (millimeters).
  - B. This drawing is subject to change without notice.
  -  Body length does not include mold flash, protrusions, or gate burrs. Mold flash, protrusions, or gate burrs shall not exceed 0.006 (0,15) each side.
  -  Body width does not include interlead flash. Interlead flash shall not exceed 0.017 (0,43) each side.
  - E. Reference JEDEC MS-012 variation AB.

D (R-PDSO-G14)

PLASTIC SMALL OUTLINE



4211283-3/E 08/12

- NOTES:
- A. All linear dimensions are in millimeters.
  - B. This drawing is subject to change without notice.
  - C. Publication IPC-7351 is recommended for alternate designs.
  - D. Laser cutting apertures with trapezoidal walls and also rounding corners will offer better paste release. Customers should contact their board assembly site for stencil design recommendations. Refer to IPC-7525 for other stencil recommendations.
  - E. Customers should contact their board fabrication site for solder mask tolerances between and around signal pads.

PW (R-PDSO-G14)

PLASTIC SMALL OUTLINE

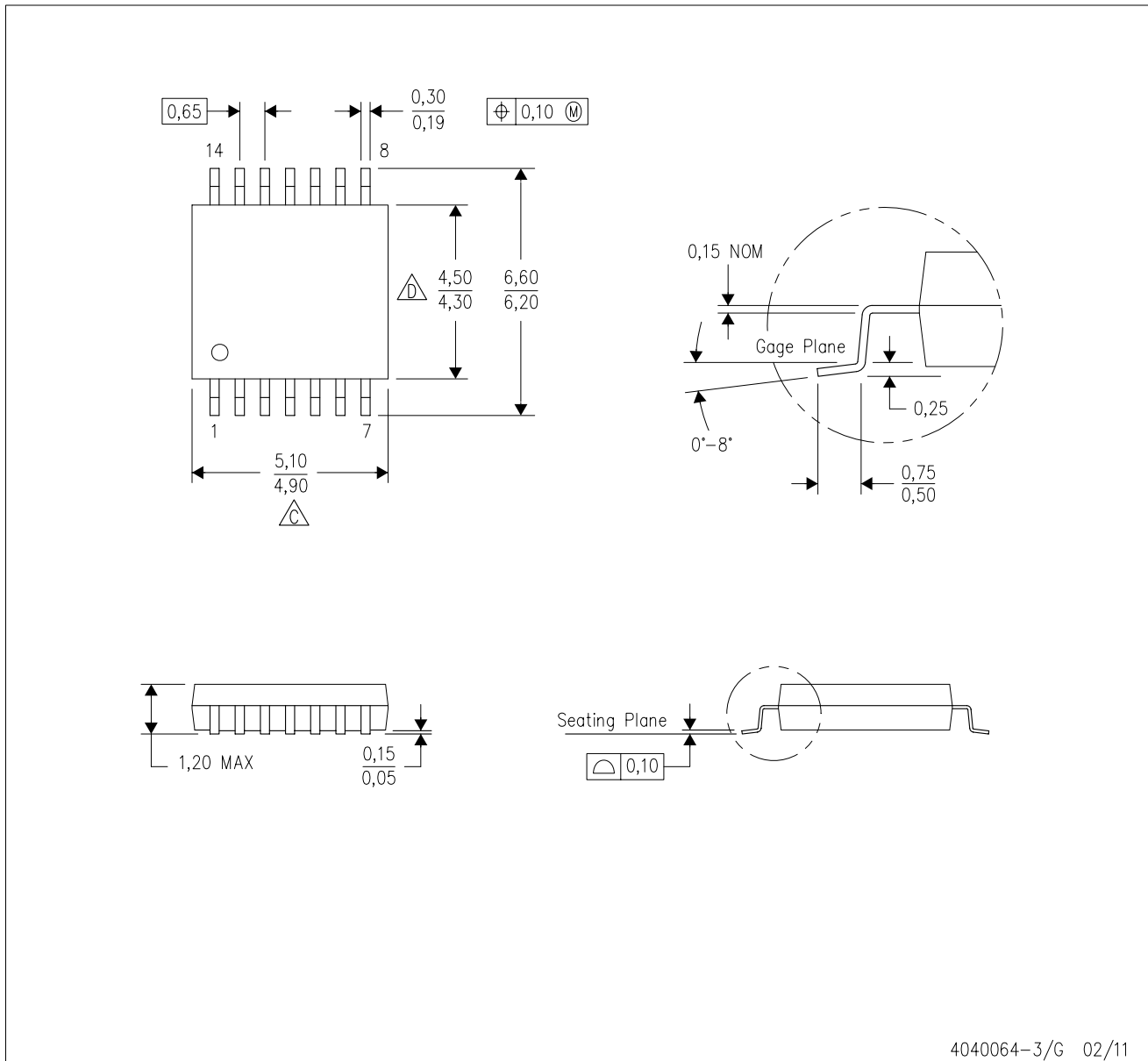

4040064-3/G 02/11

- NOTES:
- A. All linear dimensions are in millimeters. Dimensioning and tolerancing per ASME Y14.5M-1994.
  - B. This drawing is subject to change without notice.
  - C. Body length does not include mold flash, protrusions, or gate burrs. Mold flash, protrusions, or gate burrs shall not exceed 0,15 each side.
  - D. Body width does not include interlead flash. Interlead flash shall not exceed 0,25 each side.
  - E. Falls within JEDEC MO-153

PW (R-PDSO-G14)

PLASTIC SMALL OUTLINE



4211284-2/G 08/15

- NOTES:
- All linear dimensions are in millimeters.
  - This drawing is subject to change without notice.
  - Publication IPC-7351 is recommended for alternate designs.
  - Laser cutting apertures with trapezoidal walls and also rounding corners will offer better paste release. Customers should contact their board assembly site for stencil design recommendations. Refer to IPC-7525 for other stencil recommendations.
  - Customers should contact their board fabrication site for solder mask tolerances between and around signal pads.

## IMPORTANT NOTICE

Texas Instruments Incorporated and its subsidiaries (TI) reserve the right to make corrections, enhancements, improvements and other changes to its semiconductor products and services per JESD46, latest issue, and to discontinue any product or service per JESD48, latest issue. Buyers should obtain the latest relevant information before placing orders and should verify that such information is current and complete. All semiconductor products (also referred to herein as "components") are sold subject to TI's terms and conditions of sale supplied at the time of order acknowledgment.

TI warrants performance of its components to the specifications applicable at the time of sale, in accordance with the warranty in TI's terms and conditions of sale of semiconductor products. Testing and other quality control techniques are used to the extent TI deems necessary to support this warranty. Except where mandated by applicable law, testing of all parameters of each component is not necessarily performed.

TI assumes no liability for applications assistance or the design of Buyers' products. Buyers are responsible for their products and applications using TI components. To minimize the risks associated with Buyers' products and applications, Buyers should provide adequate design and operating safeguards.

TI does not warrant or represent that any license, either express or implied, is granted under any patent right, copyright, mask work right, or other intellectual property right relating to any combination, machine, or process in which TI components or services are used. Information published by TI regarding third-party products or services does not constitute a license to use such products or services or a warranty or endorsement thereof. Use of such information may require a license from a third party under the patents or other intellectual property of the third party, or a license from TI under the patents or other intellectual property of TI.

Reproduction of significant portions of TI information in TI data books or data sheets is permissible only if reproduction is without alteration and is accompanied by all associated warranties, conditions, limitations, and notices. TI is not responsible or liable for such altered documentation. Information of third parties may be subject to additional restrictions.

Resale of TI components or services with statements different from or beyond the parameters stated by TI for that component or service voids all express and any implied warranties for the associated TI component or service and is an unfair and deceptive business practice. TI is not responsible or liable for any such statements.

Buyer acknowledges and agrees that it is solely responsible for compliance with all legal, regulatory and safety-related requirements concerning its products, and any use of TI components in its applications, notwithstanding any applications-related information or support that may be provided by TI. Buyer represents and agrees that it has all the necessary expertise to create and implement safeguards which anticipate dangerous consequences of failures, monitor failures and their consequences, lessen the likelihood of failures that might cause harm and take appropriate remedial actions. Buyer will fully indemnify TI and its representatives against any damages arising out of the use of any TI components in safety-critical applications.

In some cases, TI components may be promoted specifically to facilitate safety-related applications. With such components, TI's goal is to help enable customers to design and create their own end-product solutions that meet applicable functional safety standards and requirements. Nonetheless, such components are subject to these terms.

No TI components are authorized for use in FDA Class III (or similar life-critical medical equipment) unless authorized officers of the parties have executed a special agreement specifically governing such use.

Only those TI components which TI has specifically designated as military grade or "enhanced plastic" are designed and intended for use in military/aerospace applications or environments. Buyer acknowledges and agrees that any military or aerospace use of TI components which have **not** been so designated is solely at the Buyer's risk, and that Buyer is solely responsible for compliance with all legal and regulatory requirements in connection with such use.

TI has specifically designated certain components as meeting ISO/TS16949 requirements, mainly for automotive use. In any case of use of non-designated products, TI will not be responsible for any failure to meet ISO/TS16949.

### Products

Audio	<a href="http://www.ti.com/audio">www.ti.com/audio</a>
Amplifiers	<a href="http://amplifier.ti.com">amplifier.ti.com</a>
Data Converters	<a href="http://dataconverter.ti.com">dataconverter.ti.com</a>
DLP® Products	<a href="http://www.dlp.com">www.dlp.com</a>
DSP	<a href="http://dsp.ti.com">dsp.ti.com</a>
Clocks and Timers	<a href="http://www.ti.com/clocks">www.ti.com/clocks</a>
Interface	<a href="http://interface.ti.com">interface.ti.com</a>
Logic	<a href="http://logic.ti.com">logic.ti.com</a>
Power Mgmt	<a href="http://power.ti.com">power.ti.com</a>
Microcontrollers	<a href="http://microcontroller.ti.com">microcontroller.ti.com</a>
RFID	<a href="http://www.ti-rfid.com">www.ti-rfid.com</a>
OMAP Applications Processors	<a href="http://www.ti.com/omap">www.ti.com/omap</a>
Wireless Connectivity	<a href="http://www.ti.com/wirelessconnectivity">www.ti.com/wirelessconnectivity</a>

### Applications

Automotive and Transportation	<a href="http://www.ti.com/automotive">www.ti.com/automotive</a>
Communications and Telecom	<a href="http://www.ti.com/communications">www.ti.com/communications</a>
Computers and Peripherals	<a href="http://www.ti.com/computers">www.ti.com/computers</a>
Consumer Electronics	<a href="http://www.ti.com/consumer-apps">www.ti.com/consumer-apps</a>
Energy and Lighting	<a href="http://www.ti.com/energy">www.ti.com/energy</a>
Industrial	<a href="http://www.ti.com/industrial">www.ti.com/industrial</a>
Medical	<a href="http://www.ti.com/medical">www.ti.com/medical</a>
Security	<a href="http://www.ti.com/security">www.ti.com/security</a>
Space, Avionics and Defense	<a href="http://www.ti.com/space-avionics-defense">www.ti.com/space-avionics-defense</a>
Video and Imaging	<a href="http://www.ti.com/video">www.ti.com/video</a>

### TI E2E Community

[e2e.ti.com](http://e2e.ti.com)