

FEATURES

- Specified Break-Before-Make Switching
- Low ON-State Resistance (0.65 Ω Max)
- Low Charge Injection
- Excellent ON-State Resistance Matching
- Low Total Harmonic Distortion (THD)
- 1.65-V to 3.6-V Single-Supply Operation
- Latch-Up Performance Exceeds 100 mA Per JESD 78, Class II
- ESD Performance Tested Per JESD 22
 - 2000-V Human-Body Model (A114-B, Class II)
 - 1000-V Charged-Device Model (C101)

APPLICATIONS

- Cell Phones
- PDAs
- Portable Instrumentation
- Audio and Video Signal Routing
- Low-Voltage Data Acquisition Systems
- Communication Circuits
- Modems
- Hard Drives
- Computer Peripherals
- Wireless Terminals and Peripherals

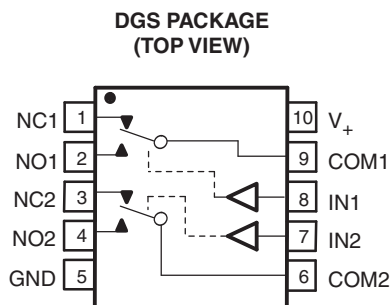
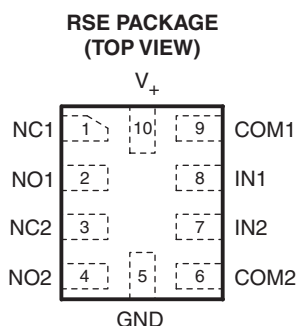

DESCRIPTION/ORDERING INFORMATION

The TS3A24157 is a dual single-pole double-throw (SPDT) analog switch that is designed to operate from 1.4 V to 3.6 V. The device offers low ON-state resistance and excellent ON-state resistance matching with the break-before-make feature, to prevent signal distortion during the transfer of a signal from one channel to another. The device has excellent total harmonic distortion (THD) performance and consumes very low power. These features make this device suitable for portable audio applications.

ORDERING INFORMATION

T _A	PACKAGE ⁽¹⁾⁽²⁾		ORDERABLE PART NUMBER	TOP-SIDE MARKING
–40°C to 85°C	QFN – RSE	Tape and reel	TS3A24157RSER	JZ0
	VSSOP – DGS (MSOP)	Tape and reel	TS3A24157DGSR	JZ0

(1) Package drawings, thermal data, and symbolization are available at www.ti.com/packaging.

(2) For the most current package and ordering information, see the Package Option Addendum at the end of this document, or see the TI website at www.ti.com.

FUNCTION TABLE

IN	NC TO COM, COM TO NC	NO TO COM, COM TO NO
L	ON	OFF
H	OFF	ON



Please be aware that an important notice concerning availability, standard warranty, and use in critical applications of Texas Instruments semiconductor products and disclaimers thereto appears at the end of this data sheet.

TS3A24157
0.65-Ω DUAL SPDT ANALOG SWITCH
DUAL-CHANNEL 2:1 MULTIPLEXER/DEMULPLEXER

SCDS208A–JUNE 2007–REVISED SEPTEMBER 2007

SUMMARY OF CHARACTERISTICS

$V_+ = 3\text{ V}$, $T_A = 25^\circ\text{C}$

Configuration	Dual 2:1 Multiplexer/ Demultiplexer (2× SPDT)
Number of channels	2
ON-state resistance (r_{on})	0.65 Ω max
ON-state resistance match (Δr_{on})	0.07 Ω max
ON-state resistance flatness ($r_{on(flat)}$)	0.04 Ω max
Turn-on/turn-off time (t_{ON}/t_{OFF})	35 ns/25 ns
Break-before-make time (t_{BBM})	25 ns
Charge injection (Q_C)	8.75 pC
Bandwidth (BW)	50 MHz
OFF isolation (O_{ISO})	−72 dB
Crosstalk (X_{TALK})	−72 dB
Total harmonic distortion (THD)	0.005%
Power-supply current (I_+)	15 nA
Package options	10-pin QFN, 10-pin VSSOP

Absolute Maximum Ratings⁽¹⁾⁽²⁾

over operating free-air temperature range (unless otherwise noted)

		MIN	MAX	UNIT
V_+	Supply voltage range ⁽³⁾	−0.5	3.6	V
V_{NC} V_{NO} V_{COM}	Analog voltage range ⁽³⁾⁽⁴⁾⁽⁵⁾	−0.5	$V_+ + 0.5$	V
I_{VOK}	Analog port diode current	$V_{NC}, V_{NO}, V_{COM} < 0$		mA
I_{NC} I_{NO} I_{COM}	ON-state switch current ON-state peak switch current ⁽⁶⁾	$V_{NC}, V_{NO}, V_{COM} = 0 \text{ to } V_+$		mA
V_I	Digital input voltage range	−0.5	3.6	V
I_{IK}	Digital input clamp current ⁽³⁾⁽⁴⁾	$V_I < 0$		mA
I_+	Continuous current through V_+		100	mA
I_{GND}	Continuous current through GND	−100		mA
T_{stg}	Storage temperature range	−65	150	°C

- (1) Stresses beyond those listed under "absolute maximum ratings" may cause permanent damage to the device. These are stress ratings only, and functional operation of the device at these or any other conditions beyond those indicated under "recommended operating conditions" is not implied. Exposure to absolute-maximum-rated conditions for extended periods may affect device reliability.
- (2) The algebraic convention, whereby the most negative value is a minimum and the most positive value is a maximum.
- (3) All voltages are with respect to ground, unless otherwise specified.
- (4) The input and output voltage ratings may be exceeded if the input and output clamp-current ratings are observed.
- (5) This value is limited to 5.5 V maximum.
- (6) Pulse at 1-ms duration <10% duty cycle.

Package Thermal Impedance

over operating free-air temperature range (unless otherwise noted)

		TYP	UNIT
θ_{JA}	Package thermal impedance ⁽¹⁾	DGS package	165
		RSE package	243

- (1) The package thermal impedance is calculated in accordance with JESD 51-7.

Electrical Characteristics for 3-V Supply⁽¹⁾
 $V_+ = 2.7\text{ V to }3.6\text{ V}$, $T_A = -40^\circ\text{C to }85^\circ\text{C}$ (unless otherwise noted)

PARAMETER	SYMBOL	TEST CONDITIONS	T_A	V_+	MIN	TYP	MAX	UNIT
Analog Switch								
Analog signal range	V_{COM}, V_{NO}, V_{NC}				0		V_+	V
Peak ON resistance	r_{peak}	$0 \leq (V_{NO} \text{ or } V_{NC}) \leq V_+$, $I_{COM} = -100\text{ mA}$,	Switch ON, See Figure 10	25°C Full	2.7 V	0.5	0.65 0.75	Ω
ON-state resistance	r_{on}	$V_{NO} \text{ or } V_{NC} = 2\text{ V}$, $I_{COM} = -100\text{ mA}$,	Switch ON, See Figure 10	25°C Full	2.7 V	0.45	0.6 0.65	Ω
ON-state resistance match between channels	Δr_{on}	$V_{NO} \text{ or } V_{NC} = 2\text{ V}, 0.8\text{ V}$, $I_{COM} = -100\text{ mA}$,	Switch ON, See Figure 10	25°C Full	2.7 V	0.05	0.07 0.08	Ω
ON-state resistance flatness	$r_{on(flat)}$	$0 \leq (V_{NO} \text{ or } V_{NC}) \leq V_+$, $I_{COM} = -100\text{ mA}$,	Switch ON, See Figure 10	25°C Full	2.7 V	0.025	0.01 0.04 0.1	Ω
NC, NO OFF leakage current	$I_{NC(OFF)}, I_{NO(OFF)}$	$V_{NC} \text{ or } V_{NO} = 1\text{ V}, V_{COM} = 3\text{ V}$, or $V_{NC} \text{ or } V_{NO} = 3\text{ V}, V_{COM} = 1\text{ V}$,	Switch OFF, See Figure 11	25°C Full	3.6 V	-50	50 250	nA
NC, NO ON leakage current	$I_{NC(ON)}, I_{NO(ON)}$	$V_{NC} \text{ or } V_{NO} = 1\text{ V}, V_{COM} = \text{Open}$, or $V_{NC} \text{ or } V_{NO} = 3\text{ V}, V_{COM} = \text{Open}$,	Switch ON, See Figure 12	25°C Full	3.6 V	-50	50 400	nA
COM ON leakage current	$I_{COM(ON)}$	$V_{NC} \text{ or } V_{NO} = \text{Open}, V_{COM} = 1\text{ V}$, or $V_{NC} \text{ or } V_{NO} = \text{Open}, V_{COM} = 3\text{ V}$,	Switch ON, See Figure 12	25°C Full	3.6 V	-50	50 400	nA
Digital Control Inputs (IN1, IN2)⁽²⁾								
Input logic high	V_{IH}			Full		1.4		V
Input logic low	V_{IL}			Full			0.5	V
Input leakage current	I_{IH}, I_{IL}	$V_I = 3.6\text{ V or }0$		25°C Full	3.6 V	-50	5 50 150	nA

(1) The algebraic convention, whereby the most negative value is a minimum and the most positive value is a maximum

(2) All unused digital inputs of the device must be held at V_+ or GND to ensure proper device operation. Refer to the TI application report, *Implications of Slow or Floating CMOS Inputs*, literature number SCBA004.

TS3A24157
0.65-Ω DUAL SPDT ANALOG SWITCH
DUAL-CHANNEL 2:1 MULTIPLEXER/DEMULTIPLEXER

SCDS208A–JUNE 2007–REVISED SEPTEMBER 2007

Electrical Characteristics for 3-V Supply⁽¹⁾ (Continued)

$V_+ = 2.7\text{ V to }3.6\text{ V}$, $T_A = -40^\circ\text{C to }85^\circ\text{C}$ (unless otherwise noted)

PARAMETER	SYMBOL	TEST CONDITIONS	T_A	V_+	MIN	TYP	MAX	UNIT	
Dynamic									
Turn-on time	t_{ON}	$V_{COM} = V_+$, $R_L = 50\ \Omega$,	$C_L = 35\text{ pF}$, See Figure 14	25°C	3 V	20	35	ns	
				Full	2.7 V to 3.6 V		40		
Turn-off time	t_{OFF}	$V_{COM} = V_+$, $R_L = 50\ \Omega$,	$C_L = 35\text{ pF}$, See Figure 14	25°C	3 V	12	25	ns	
				Full	2.7 V to 3.6 V		30		
Break-before-make time	t_{BBM}	$V_{NC} = V_{NO} = V_+$, $R_L = 50\ \Omega$,	$C_L = 35\text{ pF}$, See Figure 15	25°C	3 V	1	10	25	ns
				Full	2.7 V to 3.6 V	0.5		30	
Charge injection	Q_C	$V_{GEN} = 0$, $R_{GEN} = 0$,	$C_L = 1\text{ nF}$, See Figure 19	25°C	3 V	8.75		pC	
NC, NO OFF capacitance	$C_{NC(OFF)}$, $C_{NO(OFF)}$	V_{NC} or $V_{NO} = V_+$ or GND, Switch OFF,	See Figure 13	25°C	3 V	50		pF	
NC, NO ON capacitance	$C_{NC(ON)}$, $C_{NO(ON)}$	V_{NC} or $V_{NO} = V_+$ or GND, Switch ON,	See Figure 13	25°C	3 V	140		pF	
COM ON capacitance	$C_{COM(ON)}$	$V_{COM} = V_+$ or GND, Switch ON,	See Figure 13	25°C	3 V	140		pF	
Digital input capacitance	C_I	$V_I = V_+$ or GND,	See Figure 13	25°C	3 V	2		pF	
Bandwidth	BW	$R_L = 50\ \Omega$, Switch ON,	See Figure 16	25°C	3 V	50		MHz	
OFF isolation	O_{ISO}	$R_L = 50\ \Omega$, $f = 1\text{ MHz}$,	See Figure 17	25°C	3 V	-72		dB	
Crosstalk	X_{TALK}	$R_L = 50\ \Omega$, $f = 1\text{ MHz}$,	See Figure 18	25°C	3 V	-72		dB	
Total harmonic distortion	THD	$R_L = 600\ \Omega$, $C_L = 50\text{ pF}$,	$f = 20\text{ Hz to }20\text{ kHz}$, See Figure 20	25°C	3 V	0.005		%	
Supply									
Positive supply current	I_+	$V_I = V_+$ or GND	25°C	3.6 V	15	200		nA	
			Full			1200			

(1) The algebraic convention, whereby the most negative value is a minimum and the most positive value is a maximum

Electrical Characteristics for 2.5-V Supply⁽¹⁾
 $V_+ = 2.3 \text{ V to } 2.7 \text{ V}$, $T_A = -40^\circ\text{C to } 85^\circ\text{C}$ (unless otherwise noted)

PARAMETER	SYMBOL	TEST CONDITIONS	T_A	V_+	MIN	TYP	MAX	UNIT
Analog Switch								
Analog signal range	V_{COM}, V_{NO}, V_{NC}				0		V_+	V
Peak ON resistance	r_{peak}	$0 \leq (V_{NO} \text{ or } V_{NC}) \leq V_+$, $I_{COM} = -8 \text{ mA}$,	Switch ON, See Figure 10	25°C Full	2.3 V	0.55	0.75 0.9	Ω
ON-state resistance	r_{on}	$V_{NO} \text{ or } V_{NC} = 1.8 \text{ V}$, $I_{COM} = -8 \text{ mA}$,	Switch ON, See Figure 10	25°C Full	2.3 V	0.56	0.75 0.85	Ω
ON-state resistance match between channels	Δr_{on}	$V_{NO} \text{ or } V_{NC} = 1.8 \text{ V}, 0.8 \text{ V}$, $I_{COM} = -8 \text{ mA}$,	Switch ON, See Figure 10	25°C Full	2.3 V	0.1	0.15 0.15	Ω
ON-state resistance flatness	$r_{on(flat)}$	$0 \leq (V_{NO} \text{ or } V_{NC}) \leq V_+$, $I_{COM} = -8 \text{ mA}$,	Switch ON, See Figure 10	25°C	2.3 V	0.1	0.15	Ω
		$V_{NO} \text{ or } V_{NC} = 0.8 \text{ V}, 1.8 \text{ V}$, $I_{COM} = -8 \text{ mA}$,	Switch ON, See Figure 10	25°C				
			Full	Full	0.2			
NC, NO OFF leakage current	$I_{NC(OFF)}, I_{NO(OFF)}$	$V_{NC} \text{ or } V_{NO} = 0.5 \text{ V}, V_{COM} = 2.2 \text{ V}$, or $V_{NC} \text{ or } V_{NO} = 2.2 \text{ V}, V_{COM} = 0.5 \text{ V}$,	Switch OFF, See Figure 11	25°C Full	2.7 V	-50	50 250	nA
NC, NO ON leakage current	$I_{NC(ON)}, I_{NO(ON)}$	$V_{NC} \text{ or } V_{NO} = 0.5 \text{ V}, V_{COM} = \text{Open}$, or $V_{NC} \text{ or } V_{NO} = 2.2 \text{ V}, V_{COM} = \text{Open}$,	Switch ON, See Figure 12	25°C Full	2.7 V	-50	50 400	nA
COM ON leakage current	$I_{COM(ON)}$	$V_{NC} \text{ or } V_{NO} = \text{Open}, V_{COM} = 0.5 \text{ V}$, or $V_{NC} \text{ or } V_{NO} = \text{Open}, V_{COM} = 2.2 \text{ V}$,	Switch ON, See Figure 12	25°C Full	2.7 V	-50	50 400	nA
Digital Control Inputs (IN1, IN2)⁽²⁾								
Input logic high	V_{IH}			Full		1.25		V
Input logic low	V_{IL}			Full			0.5	V
Input leakage current	I_{IH}, I_{IL}	$V_I = 2.7 \text{ V or } 0$		25°C Full	2.7 V	-50	50 50	nA

(1) The algebraic convention, whereby the most negative value is a minimum and the most positive value is a maximum

(2) All unused digital inputs of the device must be held at V_+ or GND to ensure proper device operation. Refer to the TI application report, *Implications of Slow or Floating CMOS Inputs*, literature number SCBA004.

TS3A24157
0.65-Ω DUAL SPDT ANALOG SWITCH
DUAL-CHANNEL 2:1 MULTIPLEXER/DEMULTIPLEXER

SCDS208A–JUNE 2007–REVISED SEPTEMBER 2007

Electrical Characteristics for 2.5-V Supply⁽¹⁾ (Continued)

$V_+ = 2.3 \text{ V to } 2.7 \text{ V}$, $T_A = -40^\circ\text{C to } 85^\circ\text{C}$ (unless otherwise noted)

PARAMETER	SYMBOL	TEST CONDITIONS	T_A	V_+	MIN	TYP	MAX	UNIT	
Dynamic									
Turn-on time	t_{ON}	$V_{COM} = V_+$, $R_L = 50 \Omega$,	$C_L = 35 \text{ pF}$, See Figure 14	25°C	2.5 V	23	45	ns	
				Full	2.3 V to 2.7 V		50		
Turn-off time	t_{OFF}	$V_{COM} = V_+$, $R_L = 50 \Omega$,	$C_L = 35 \text{ pF}$, See Figure 14	25°C	2.5 V	17	27	ns	
				Full	2.3 V to 2.7 V		30		
Break-before-make time	t_{BBM}	$V_{NC} = V_{NO} = V_+$, $R_L = 50 \Omega$,	$C_L = 35 \text{ pF}$, See Figure 15	25°C	2.5 V	2	14	30	ns
				Full	2.3 V to 2.7 V	1		35	
Charge injection	Q_C	$V_{GEN} = 0$, $R_{GEN} = 0$,	$C_L = 1 \text{ nF}$, See Figure 19	25°C	2.5 V	8		pC	
NC, NO OFF capacitance	$C_{NC(OFF)}$, $C_{NO(OFF)}$	V_{NC} or $V_{NO} = V_+$ or GND, Switch OFF,	See Figure 13	25°C	2.5 V	50		pF	
NC, NO ON capacitance	$C_{NC(ON)}$, $C_{NO(ON)}$	V_{NC} or $V_{NO} = V_+$ or GND, Switch ON,	See Figure 13	25°C	2.5 V	140		pF	
COM ON capacitance	$C_{COM(ON)}$	$V_{COM} = V_+$ or GND, Switch ON,	See Figure 13	25°C	2.5 V	140		pF	
Digital input capacitance	C_I	$V_I = V_+$ or GND,	See Figure 13	25°C	2.5 V	2		pF	
Bandwidth	BW	$R_L = 50 \Omega$, Switch ON,	See Figure 16	25°C	2.5 V	50		MHz	
OFF isolation	O_{ISO}	$R_L = 50 \Omega$, $f = 1 \text{ MHz}$,	See Figure 17	25°C	2.5 V	-72		dB	
Crosstalk	X_{TALK}	$R_L = 50 \Omega$, $f = 1 \text{ MHz}$,	See Figure 18	25°C	2.5 V	-72		dB	
Total harmonic distortion	THD	$R_L = 600 \Omega$, $C_L = 50 \text{ pF}$,	$f = 20 \text{ Hz to } 20 \text{ kHz}$, See Figure 20	25°C	2.5 V	0.006		%	
Supply									
Positive supply current	I_+	$V_I = V_+$ or GND	25°C	2.7 V	10	150	nA		
			Full			700			

(1) The algebraic convention, whereby the most negative value is a minimum and the most positive value is a maximum

Electrical Characteristics for 1.8-V Supply⁽¹⁾
 $V_+ = 1.65\text{ V to }1.95\text{ V}$, $T_A = -40^\circ\text{C to }85^\circ\text{C}$ (unless otherwise noted)

PARAMETER	SYMBOL	TEST CONDITIONS	T_A	V_+	MIN	TYP	MAX	UNIT
Analog Switch								
Analog signal range	V_{COM}, V_{NO}, V_{NC}				0		V_+	V
Peak ON resistance	r_{peak}	$0 \leq (V_{NO} \text{ or } V_{NC}) \leq V_+$, $I_{COM} = -2\text{ mA}$,	Switch ON, See Figure 10	25°C Full	1.65 V	0.8	1.25 1.4	Ω
ON-state resistance	r_{on}	$V_{NO} \text{ or } V_{NC} = 1.5\text{ V}$, $I_{COM} = -2\text{ mA}$,	Switch ON, See Figure 10	25°C Full	1.65 V	0.6	0.95 1	Ω
ON-state resistance match between channels	Δr_{on}	$V_{NO} \text{ or } V_{NC} = 0.6\text{ V}, 1.5\text{ V}$, $I_{COM} = -2\text{ mA}$,	Switch ON, See Figure 10	25°C Full	1.65 V	0.1	0.15 0.15	Ω
ON-state resistance flatness	$r_{on(Flat)}$	$0 \leq (V_{NO} \text{ or } V_{NC}) \leq V_+$, $I_{COM} = -2\text{ mA}$, $V_{NO} \text{ or } V_{NC} = 0.6\text{ V}, 1.5\text{ V}$, $I_{COM} = -8\text{ mA}$,	Switch ON, See Figure 10	25°C Full	1.65 V	0.35	0.13 0.05 0.2	Ω
NC, NO OFF leakage current	$I_{NC(OFF)}, I_{NO(OFF)}$	$V_{NC} \text{ or } V_{NO} = 0.3\text{ V}, V_{COM} = 1.65\text{ V}$, or $V_{NC} \text{ or } V_{NO} = 1.65\text{ V}, V_{COM} = 0.3\text{ V}$,	Switch OFF, See Figure 11	25°C Full	1.65	-50	50 250	nA
NC, NO ON leakage current	$I_{NC(ON)}, I_{NO(ON)}$	$V_{NC} \text{ or } V_{NO} = 0.3\text{ V}, V_{COM} = \text{Open}$, or $V_{NC} \text{ or } V_{NO} = 1.65\text{ V}, V_{COM} = \text{Open}$,	Switch ON, See Figure 12	25°C Full	1.95 V	-50	50 400	nA
COM ON leakage current	$I_{COM(ON)}$	$V_{NC} \text{ or } V_{NO} = \text{Open}, V_{COM} = 0.3\text{ V}$, or $V_{NC} \text{ or } V_{NO} = \text{Open}, V_{COM} = 1.65\text{ V}$,	Switch ON, See Figure 12	25°C Full	1.95 V	-50	50 400	nA
Digital Control Inputs (IN1, IN2)⁽²⁾								
Input logic high	V_{IH}			Full		1		V
Input logic low	V_{IL}			Full			0.4	V
Input leakage current	I_{IH}, I_{IL}	$V_I = 1.95\text{ V or }0$		25°C Full	1.95 V	0	50 150	nA

(1) The algebraic convention, whereby the most negative value is a minimum and the most positive value is a maximum

(2) All unused digital inputs of the device must be held at V_+ or GND to ensure proper device operation. Refer to the TI application report, *Implications of Slow or Floating CMOS Inputs*, literature number SCBA004.

TS3A24157
0.65-Ω DUAL SPDT ANALOG SWITCH
DUAL-CHANNEL 2:1 MULTIPLEXER/DEMULTIPLEXER

SCDS208A–JUNE 2007–REVISED SEPTEMBER 2007

Electrical Characteristics for 1.8-V Supply⁽¹⁾ (Continued)

$V_+ = 1.65\text{ V to }1.95\text{ V}$, $T_A = -40^\circ\text{C to }85^\circ\text{C}$ (unless otherwise noted)

PARAMETER	SYMBOL	TEST CONDITIONS	T_A	V_+	MIN	TYP	MAX	UNIT	
Dynamic									
Turn-on time	t_{ON}	$V_{COM} = V_+$, $R_L = 50\ \Omega$,	$C_L = 35\text{ pF}$, See Figure 14	25°C	1.8 V	33	75	ns	
				Full	1.65 V to 1.95 V		80		
Turn-off time	t_{OFF}	$V_{COM} = V_+$, $R_L = 50\ \Omega$,	$C_L = 35\text{ pF}$, See Figure 14	25°C	1.8 V	24	35	ns	
				Full	1.65 V to 1.95 V		40		
Break-before-make time	t_{BBM}	$V_{NC} = V_{NO} = V_+$, $R_L = 50\ \Omega$,	$C_L = 35\text{ pF}$, See Figure 15	25°C	1.8 V	2	20	40	ns
				Full	1.65 V to 1.95 V	1		50	
Charge injection	Q_C	$V_{GEN} = 0$, $R_{GEN} = 0$,	$C_L = 1\text{ nF}$, See Figure 19	25°C	1.8 V		4	pC	
NC, NO OFF capacitance	$C_{NC(OFF)}$, $C_{NO(OFF)}$	V_{NC} or $V_{NO} = V_+$ or GND, Switch OFF,	See Figure 13	25°C	1.8 V		50	pF	
NC, NO ON capacitance	$C_{NC(ON)}$, $C_{NO(ON)}$	V_{NC} or $V_{NO} = V_+$ or GND, Switch ON,	See Figure 13	25°C	1.8 V		140	pF	
COM ON capacitance	$C_{COM(ON)}$	$V_{COM} = V_+$ or GND, Switch ON,	See Figure 13	25°C	1.8 V		140	pF	
Digital input capacitance	C_I	$V_I = V_+$ or GND,	See Figure 13	25°C	1.8 V		2	pF	
Bandwidth	BW	$R_L = 50\ \Omega$, Switch ON,	See Figure 16	25°C	1.8 V		48	MHz	
OFF isolation	O_{ISO}	$R_L = 50\ \Omega$, $f = 1\text{ MHz}$,	See Figure 17	25°C	1.8 V		-73	dB	
Crosstalk	X_{TALK}	$R_L = 50\ \Omega$, $f = 1\text{ MHz}$,	See Figure 18	25°C	1.8 V		-72	dB	
Total harmonic distortion	THD	$R_L = 600\ \Omega$, $C_L = 50\text{ pF}$,	$f = 20\text{ Hz to }20\text{ kHz}$, See Figure 20	25°C	1.8 V			%	
Supply									
Positive supply current	I_+	$V_I = V_+$ or GND	25°C	1.95 V	10	100	nA		
			Full			600			

(1) The algebraic convention, whereby the most negative value is a minimum and the most positive value is a maximum

TYPICAL PERFORMANCE

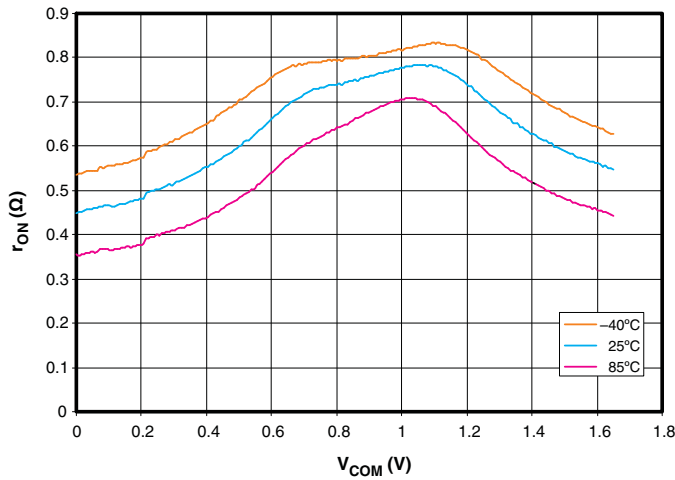

Figure 1. r_{on} vs V_{COM} ($V_+ = 1.65$ V)

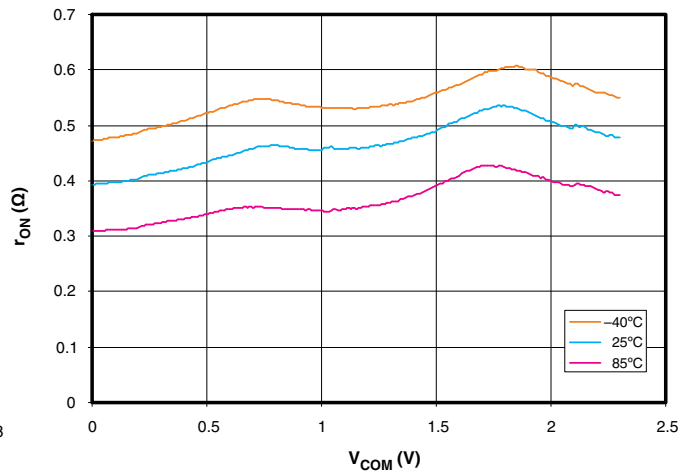

Figure 2. r_{on} vs V_{COM} ($V_+ = 2.3$ V)

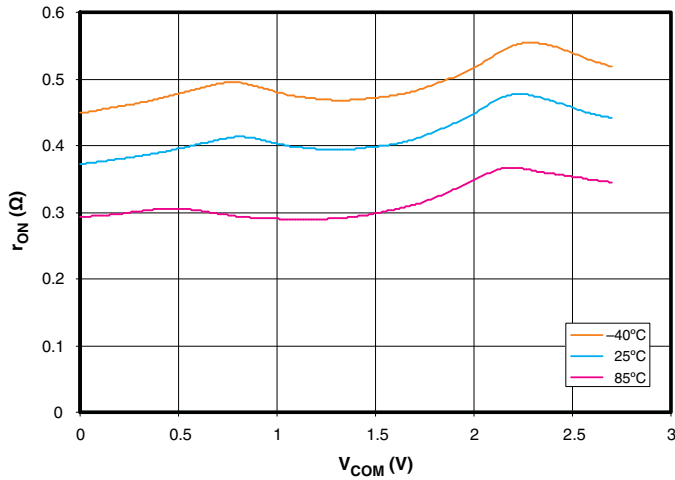

Figure 3. r_{on} vs V_{COM} ($V_+ = 2.7$ V)

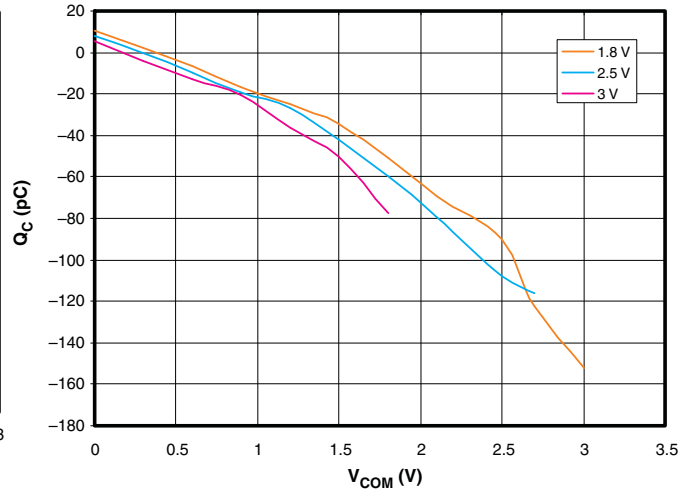

Figure 4. Charge Injection (Q_C) vs V_{COM}

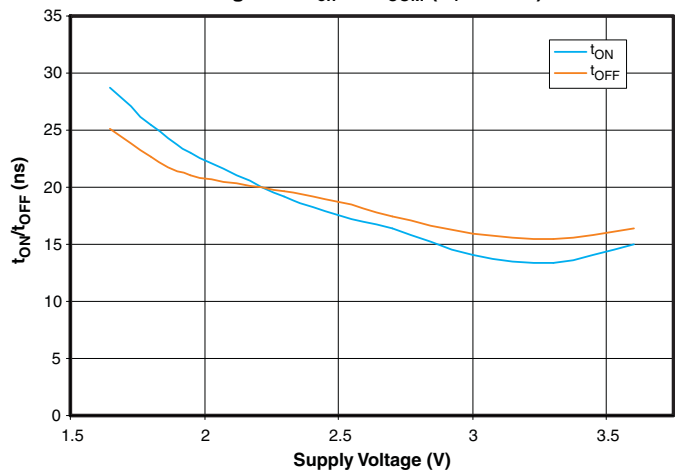

Figure 5. t_{ON} and t_{OFF} vs Supply Voltage

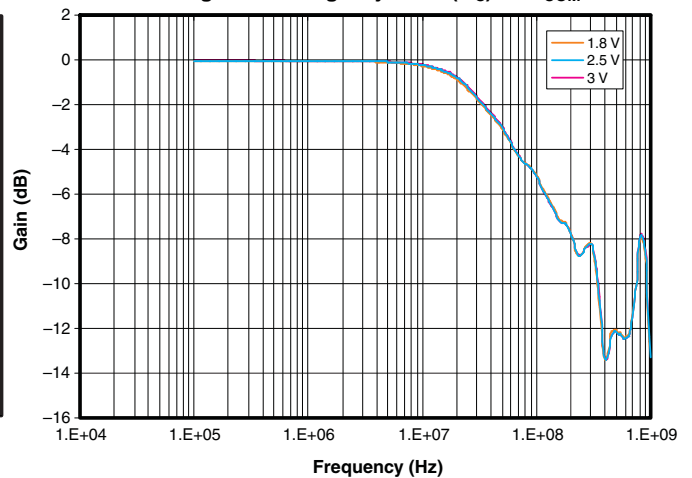

Figure 6. Bandwidth

TYPICAL PERFORMANCE (continued)

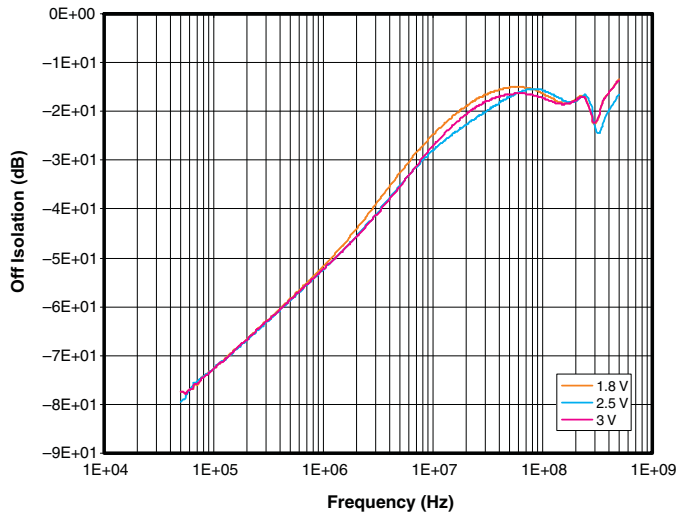

Figure 7. OFF Isolation and Crosstalk

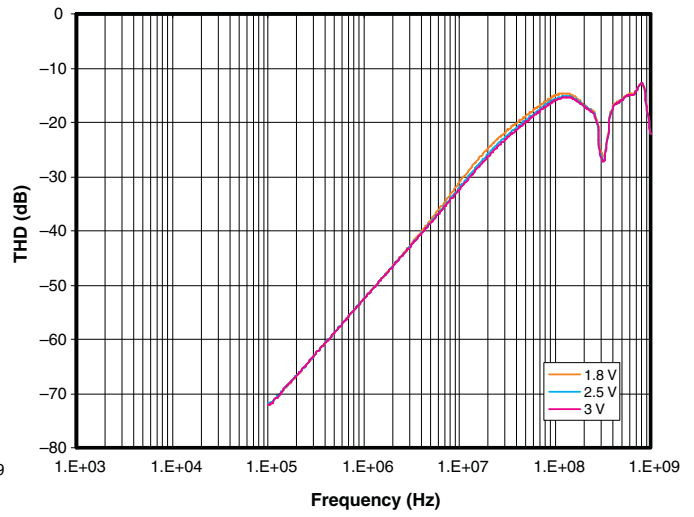

Figure 8. Total Harmonic Distortion vs Frequency

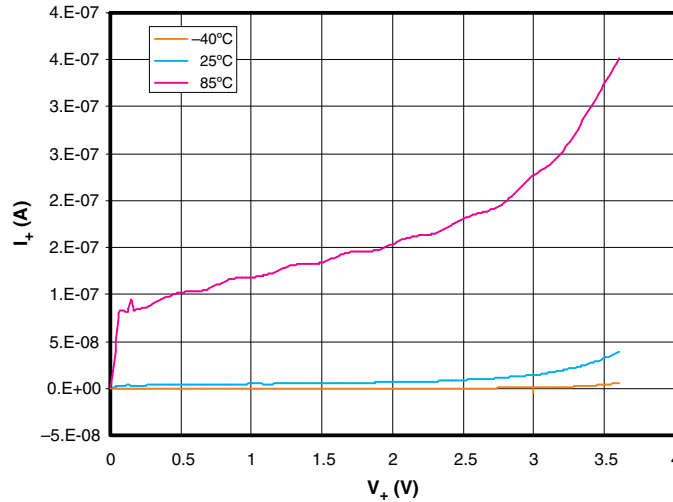

Figure 9. Power-Supply Current vs V_+

PIN DESCRIPTION

NO.	NAME	DESCRIPTION
1	NC1	Normally closed
2	NO1	Normally open
3	NC2	Normally closed
4	NO2	Normally open
5	GND	Ground
6	COM2	Common
7	IN2	Digital control to connect COM2 to NO2 or NC2
8	IN1	Digital control to connect COM1 to NO1 or NC1
9	COM1	Common
10	V ₊	Power supply

TS3A24157
0.65-Ω DUAL SPDT ANALOG SWITCH
DUAL-CHANNEL 2:1 MULTIPLEXER/DEMULTIPLEXER

SCDS208A–JUNE 2007–REVISED SEPTEMBER 2007

PARAMETER DESCRIPTION

SYMBOL	DESCRIPTION
V_{COM}	Voltage at COM
V_{NC}	Voltage at NC
V_{NO}	Voltage at NO
r_{on}	Resistance between COM and NC or COM and NO ports when the channel is ON
r_{peak}	Peak on-state resistance over a specified voltage range
Δr_{on}	Difference of r_{on} between channels in a specific device
$r_{on(flat)}$	Difference between the maximum and minimum value of r_{on} in a channel over the specified range of conditions
$I_{NC(OFF)}$	Leakage current measured at the NC port, with the corresponding channel (NC to COM) in the OFF state under worst-case input and output conditions
$I_{NC(PWROFF)}$	Leakage current measured at the NC port during the power-down condition, $V_+ = 0$
$I_{NO(OFF)}$	Leakage current measured at the NO port, with the corresponding channel (NO to COM) in the OFF state under worst-case input and output conditions
$I_{NO(PWROFF)}$	Leakage current measured at the NO port during the power-down condition, $V_+ = 0$
$I_{NC(ON)}$	Leakage current measured at the NC port, with the corresponding channel (NC to COM) in the ON state and the output (COM) open
$I_{NO(ON)}$	Leakage current measured at the NO port, with the corresponding channel (NO to COM) in the ON state and the output (COM) open
$I_{COM(ON)}$	Leakage current measured at the COM port, with the corresponding channel (COM to NO or COM to NC) in the ON state and the output (NC or NO) open
$I_{COM(PWROFF)}$	Leakage current measured at the COM port during the power-down condition, $V_+ = 0$
V_{IH}	Minimum input voltage for logic high for the control input (IN)
V_{IL}	Maximum input voltage for logic low for the control input (IN)
V_I	Voltage at the control input (IN)
I_{IH}, I_{IL}	Leakage current measured at the control input (IN)
t_{ON}	Turn-on time for the switch. This parameter is measured under the specified range of conditions and by the propagation delay between the digital control (IN) signal and analog output (COM, NC, or NO) signal when the switch is turning ON.
t_{OFF}	Turn-off time for the switch. This parameter is measured under the specified range of conditions and by the propagation delay between the digital control (IN) signal and analog output (COM, NC, or NO) signal when the switch is turning OFF.
t_{BBM}	Break-before-make time. This parameter is measured under the specified range of conditions and by the propagation delay between the output of two adjacent analog channels (NC and NO) when the control signal changes state.
Q_C	Charge injection is a measurement of unwanted signal coupling from the control (IN) input to the analog (NC, NO, or COM) output. This is measured in coulomb (C) and measured by the total charge induced due to switching of the control input. Charge injection, $Q_C = C_L \times \Delta V_{COM}$, C_L is the load capacitance and ΔV_{COM} is the change in analog output voltage.
$C_{NC(OFF)}$	Capacitance at the NC port when the corresponding channel (NC to COM) is OFF
$C_{NO(OFF)}$	Capacitance at the NO port when the corresponding channel (NO to COM) is OFF
$C_{NC(ON)}$	Capacitance at the NC port when the corresponding channel (NC to COM) is ON
$C_{NO(ON)}$	Capacitance at the NO port when the corresponding channel (NO to COM) is ON
$C_{COM(ON)}$	Capacitance at the COM port when the corresponding channel (COM to NC or COM to NO) is ON
C_I	Capacitance of control input (IN)
O_{ISO}	OFF isolation of the switch is a measurement of OFF-state switch impedance. This is measured in dB in a specific frequency, with the corresponding channel (NC to COM or NO to COM) in the OFF state.
X_{TALK}	Crosstalk is a measurement of unwanted signal coupling from an ON channel to an OFF channel (NC to NO or NO to NC). This is measured in a specific frequency and in dB.
BW	Bandwidth of the switch. This is the frequency in which the gain of an ON channel is –3 dB below the DC gain.
THD	Total harmonic distortion describes the signal distortion caused by the analog switch. This is defined as the ratio of root mean square (RMS) value of the second, third, and higher harmonic to the absolute magnitude of the fundamental harmonic.
I_+	Static power-supply current with the control (IN) pin at V_+ or GND

PARAMETER MEASUREMENT INFORMATION

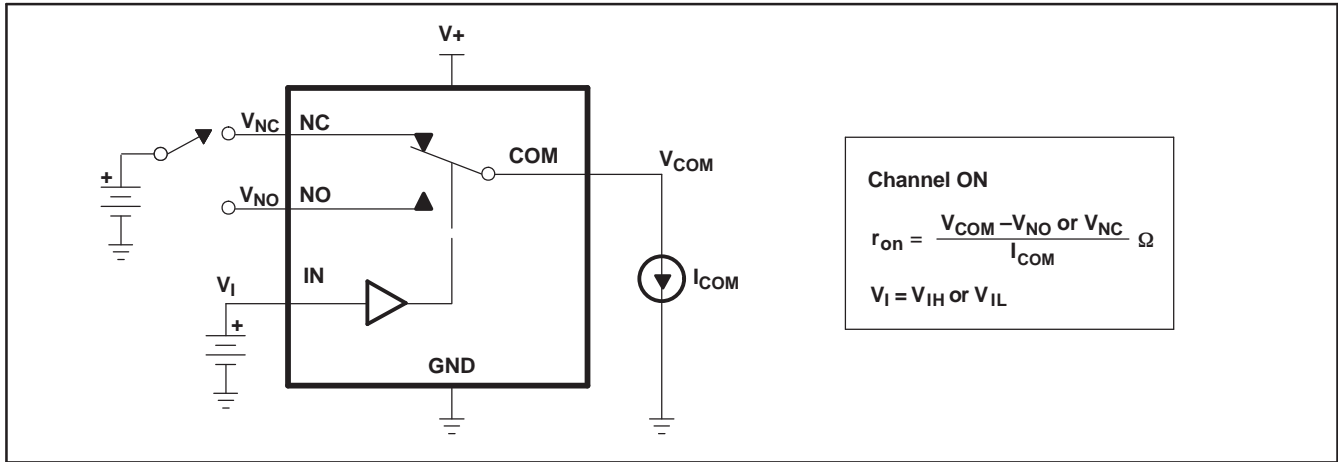

Figure 10. ON-State Resistance (r_{on})

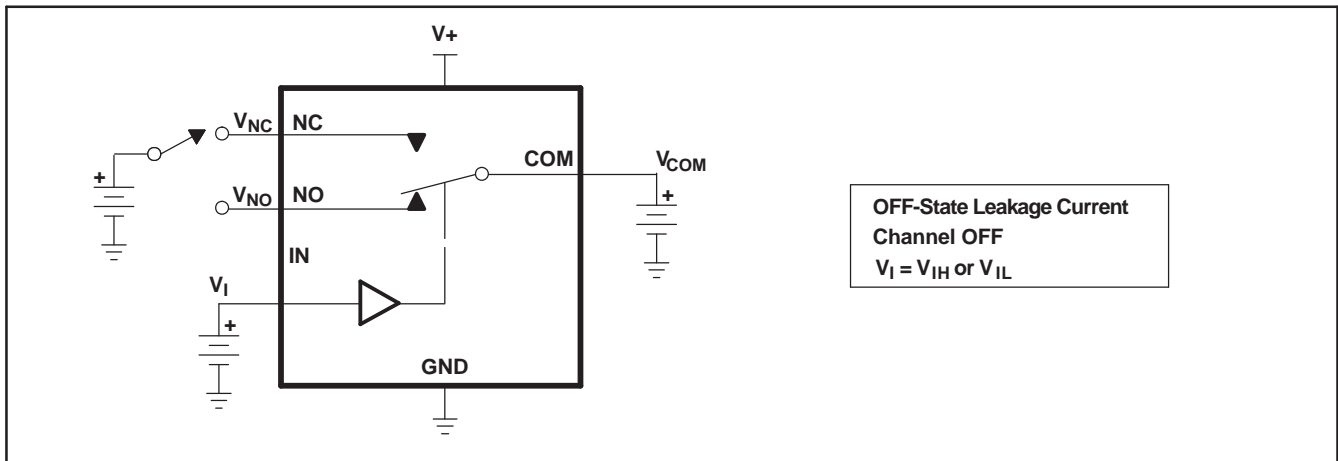

Figure 11. OFF-State Leakage Current
 ($I_{NC(OFF)}$, $I_{NC(PWROFF)}$, $I_{NO(OFF)}$, $I_{NO(PWROFF)}$, $I_{COM(OFF)}$, $I_{COM(PWROFF)}$)

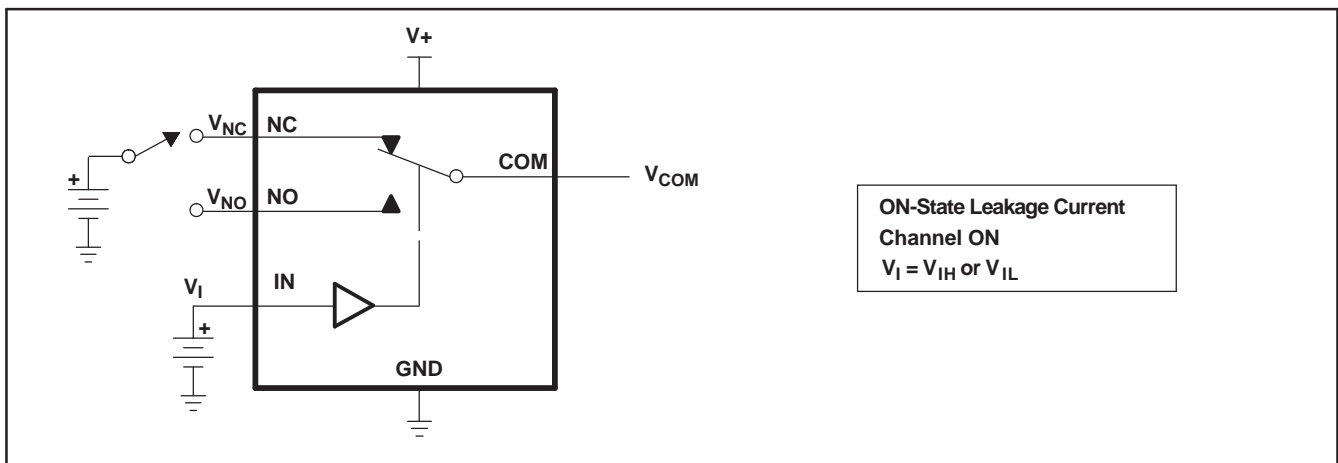

Figure 12. ON-State Leakage Current ($I_{COM(ON)}$, $I_{NC(ON)}$, $I_{NO(ON)}$)

PARAMETER MEASUREMENT INFORMATION (continued)

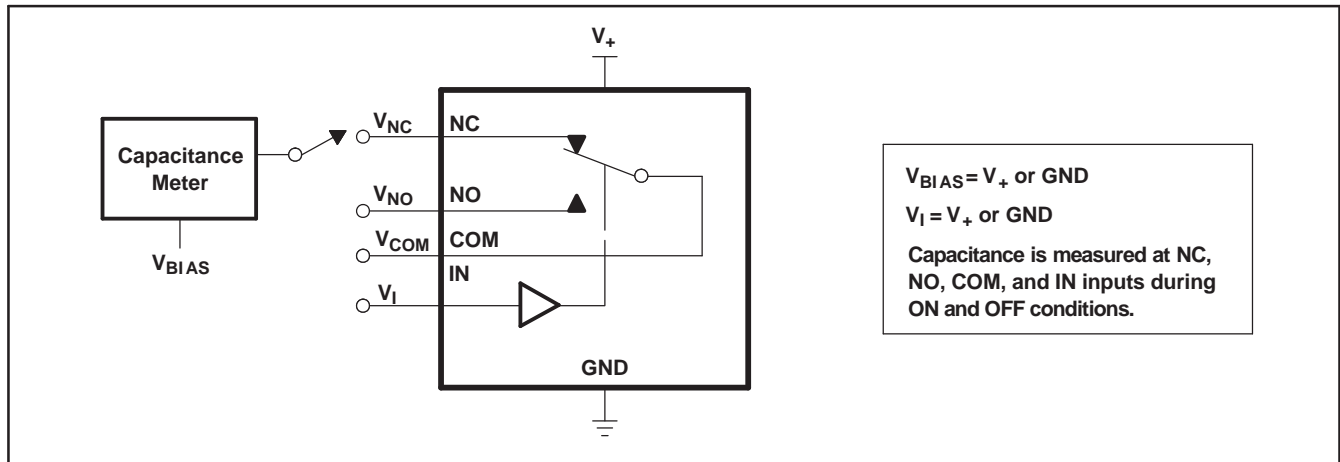
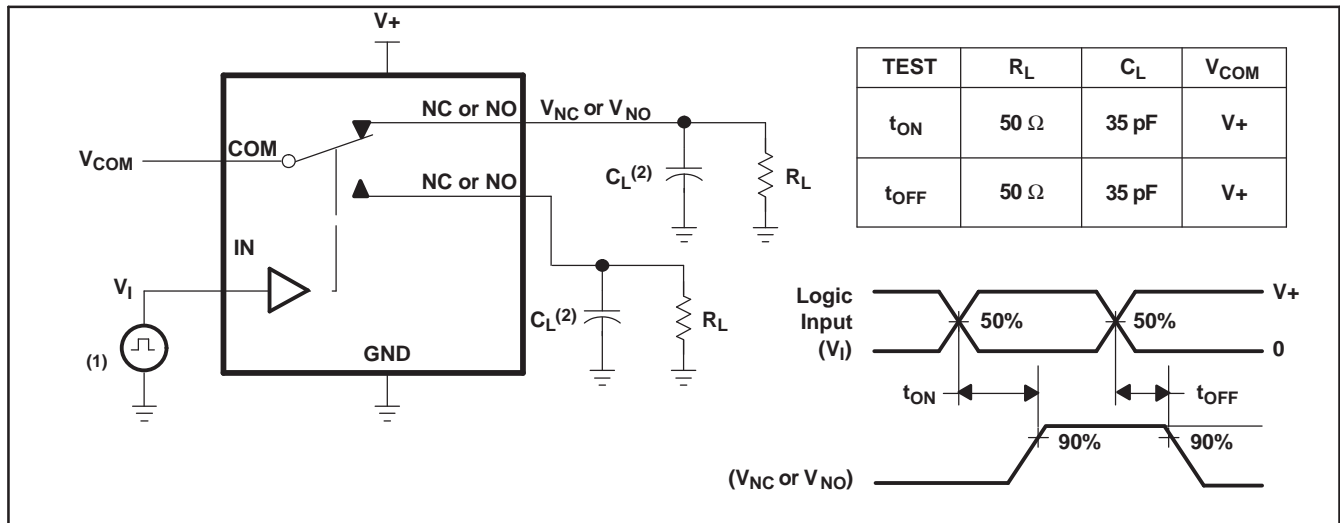

Figure 13. Capacitance (C_I , $C_{COM(ON)}$, $C_{NC(OFF)}$, $C_{NO(OFF)}$, $C_{NC(ON)}$, $C_{NO(ON)}$)



- A. All input pulses are supplied by generators having the following characteristics: PRR ≤ 10 MHz, $Z_O = 50 \Omega$, $t_r < 5 \text{ ns}$, $t_f < 5 \text{ ns}$.
- B. C_L includes probe and jig capacitance.

Figure 14. Turn-On (t_{ON}) and Turn-Off Time (t_{OFF})

PARAMETER MEASUREMENT INFORMATION (continued)

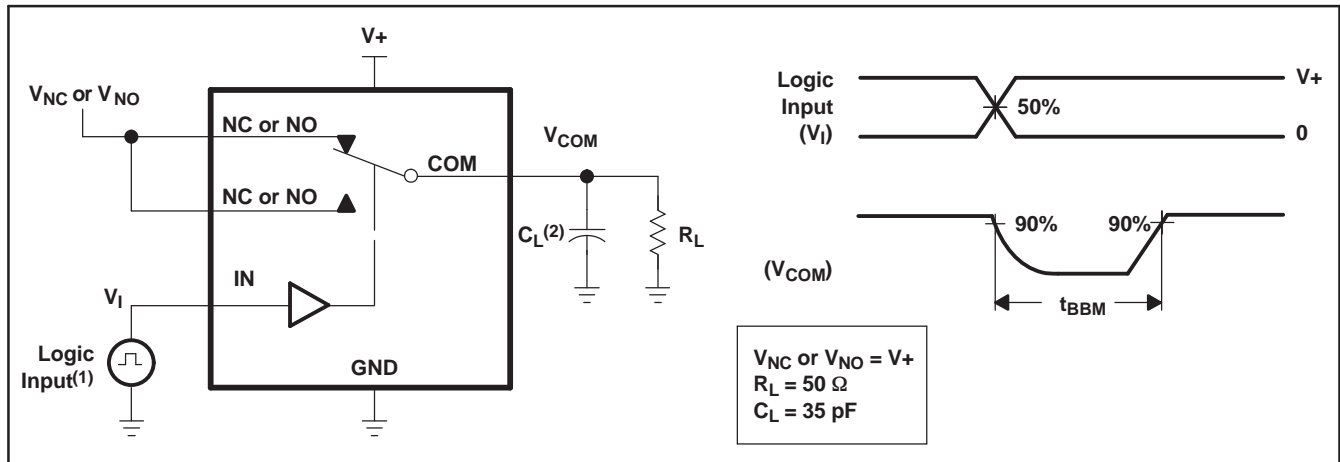

- A. All input pulses are supplied by generators having the following characteristics: PRR \leq 10 MHz, $Z_0 = 50 \Omega$, $t_r < 5$ ns, $t_f < 5$ ns.
- B. C_L includes probe and jig capacitance.

Figure 15. Break-Before-Make Time (t_{BBM})

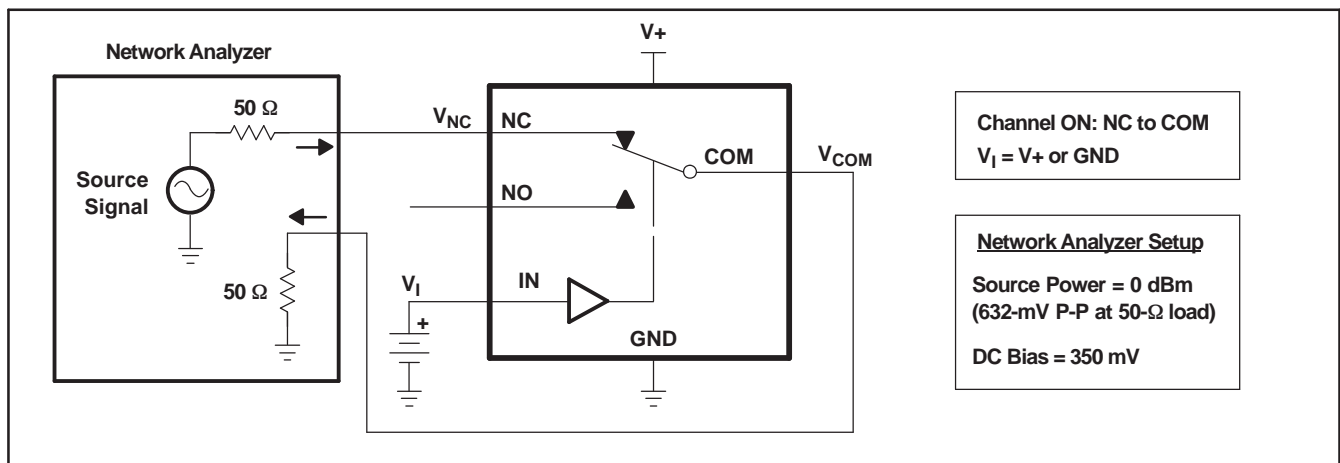

Figure 16. Bandwidth (BW)

PARAMETER MEASUREMENT INFORMATION (continued)

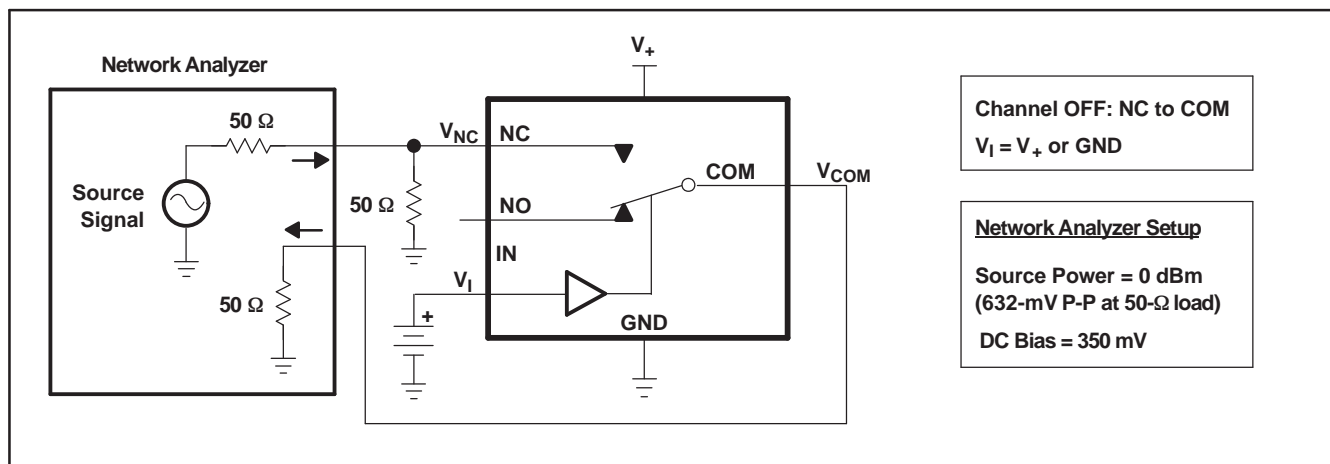

Figure 17. OFF Isolation (O_{ISO})

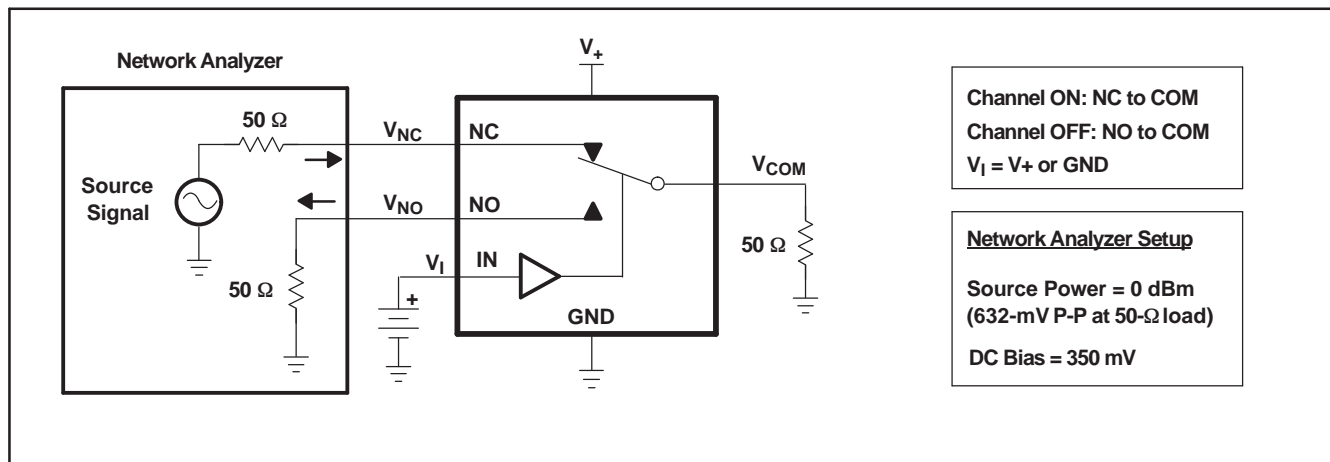
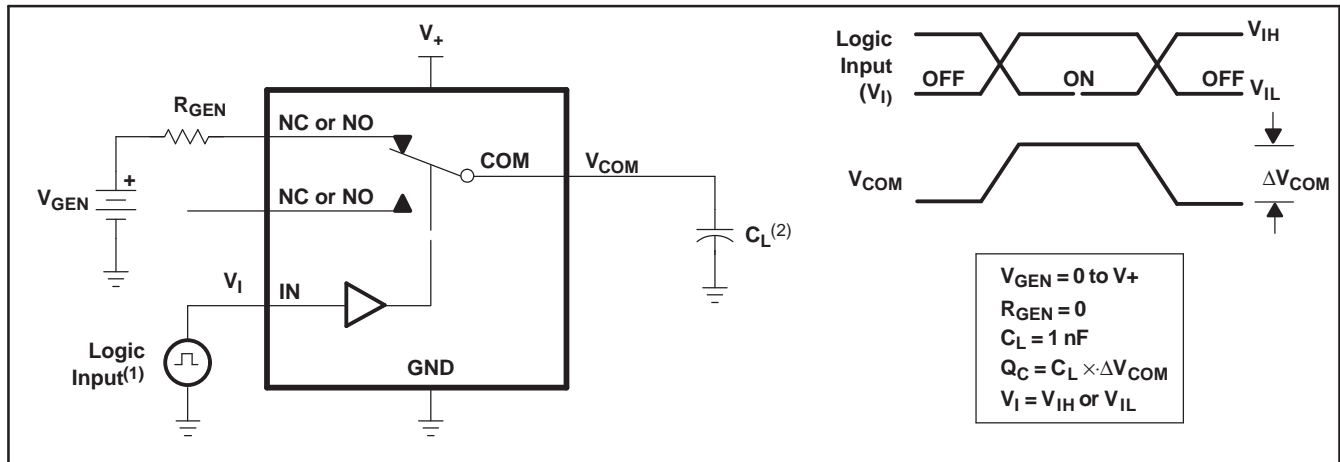

Figure 18. Crosstalk (X_{TALK})

PARAMETER MEASUREMENT INFORMATION (continued)



- A. All input pulses are supplied by generators having the following characteristics: PRR \leq 10 MHz, $Z_0 = 50 \Omega$, $t_r < 5$ ns, $t_f < 5$ ns.
- B. C_L includes probe and jig capacitance.

Figure 19. Charge Injection (Q_C)

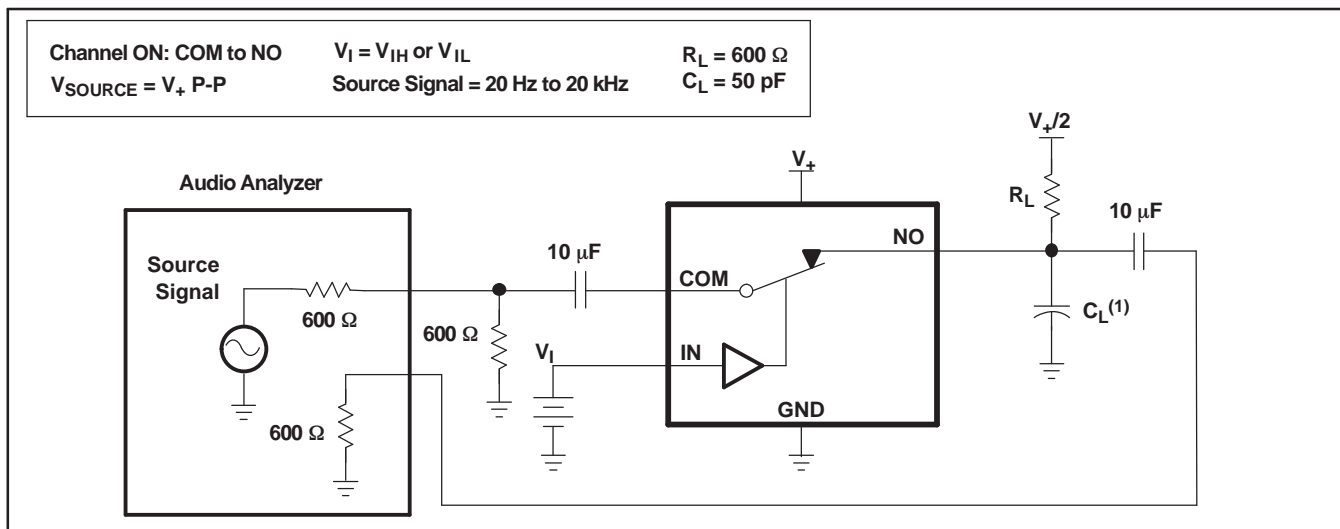

- A. C_L includes probe and jig capacitance.

Figure 20. Total Harmonic Distortion (THD)

PACKAGING INFORMATION

Orderable Device	Status (1)	Package Type	Package Drawing	Pins	Package Qty	Eco Plan (2)	Lead/Ball Finish (6)	MSL Peak Temp (3)	Op Temp (°C)	Device Marking (4/5)	Samples
TS3A24157DGSR	ACTIVE	VSSOP	DGS	10	2500	Green (RoHS & no Sb/Br)	CU NIPDAU	Level-1-260C-UNLIM	-40 to 85	(JZO ~ JZR)	Samples
TS3A24157DGSRG4	ACTIVE	VSSOP	DGS	10		TBD	Call TI	Call TI	-40 to 85		Samples
TS3A24157RSER	ACTIVE	UQFN	RSE	10	3000	Green (RoHS & no Sb/Br)	CU NIPDAU	Level-1-260C-UNLIM	-40 to 85	JZO	Samples
TS3A24157RSERG4	ACTIVE	UQFN	RSE	10	3000	Green (RoHS & no Sb/Br)	CU NIPDAU	Level-1-260C-UNLIM	-40 to 85	JZO	Samples

(1) The marketing status values are defined as follows:

ACTIVE: Product device recommended for new designs.

LIFEBUY: TI has announced that the device will be discontinued, and a lifetime-buy period is in effect.

NRND: Not recommended for new designs. Device is in production to support existing customers, but TI does not recommend using this part in a new design.

PREVIEW: Device has been announced but is not in production. Samples may or may not be available.

OBSELETE: TI has discontinued the production of the device.

(2) Eco Plan - The planned eco-friendly classification: Pb-Free (RoHS), Pb-Free (RoHS Exempt), or Green (RoHS & no Sb/Br) - please check <http://www.ti.com/productcontent> for the latest availability information and additional product content details.

TBD: The Pb-Free/Green conversion plan has not been defined.

Pb-Free (RoHS): TI's terms "Lead-Free" or "Pb-Free" mean semiconductor products that are compatible with the current RoHS requirements for all 6 substances, including the requirement that lead not exceed 0.1% by weight in homogeneous materials. Where designed to be soldered at high temperatures, TI Pb-Free products are suitable for use in specified lead-free processes.

Pb-Free (RoHS Exempt): This component has a RoHS exemption for either 1) lead-based flip-chip solder bumps used between the die and package, or 2) lead-based die adhesive used between the die and leadframe. The component is otherwise considered Pb-Free (RoHS compatible) as defined above.

Green (RoHS & no Sb/Br): TI defines "Green" to mean Pb-Free (RoHS compatible), and free of Bromine (Br) and Antimony (Sb) based flame retardants (Br or Sb do not exceed 0.1% by weight in homogeneous material)

(3) MSL, Peak Temp. - The Moisture Sensitivity Level rating according to the JEDEC industry standard classifications, and peak solder temperature.

(4) There may be additional marking, which relates to the logo, the lot trace code information, or the environmental category on the device.

(5) Multiple Device Markings will be inside parentheses. Only one Device Marking contained in parentheses and separated by a "~" will appear on a device. If a line is indented then it is a continuation of the previous line and the two combined represent the entire Device Marking for that device.

(6) Lead/Ball Finish - Orderable Devices may have multiple material finish options. Finish options are separated by a vertical ruled line. Lead/Ball Finish values may wrap to two lines if the finish value exceeds the maximum column width.

Important Information and Disclaimer: The information provided on this page represents TI's knowledge and belief as of the date that it is provided. TI bases its knowledge and belief on information provided by third parties, and makes no representation or warranty as to the accuracy of such information. Efforts are underway to better integrate information from third parties. TI has taken and continues to take reasonable steps to provide representative and accurate information but may not have conducted destructive testing or chemical analysis on incoming materials and chemicals. TI and TI suppliers consider certain information to be proprietary, and thus CAS numbers and other limited information may not be available for release.

In no event shall TI's liability arising out of such information exceed the total purchase price of the TI part(s) at issue in this document sold by TI to Customer on an annual basis.

TAPE AND REEL INFORMATION



QUADRANT ASSIGNMENTS FOR PIN 1 ORIENTATION IN TAPE



*All dimensions are nominal

Device	Package Type	Package Drawing	Pins	SPQ	Reel Diameter (mm)	Reel Width W1 (mm)	A0 (mm)	B0 (mm)	K0 (mm)	P1 (mm)	W (mm)	Pin1 Quadrant
TS3A24157DGSR	VSSOP	DGS	10	2500	330.0	12.4	5.3	3.3	1.3	8.0	12.0	Q1
TS3A24157RSER	UQFN	RSE	10	3000	179.0	8.4	1.75	2.25	0.65	4.0	8.0	Q1

TAPE AND REEL BOX DIMENSIONS

*All dimensions are nominal

Device	Package Type	Package Drawing	Pins	SPQ	Length (mm)	Width (mm)	Height (mm)
TS3A24157DGSR	VSSOP	DGS	10	2500	346.0	346.0	35.0
TS3A24157RSER	UQFN	RSE	10	3000	203.0	203.0	35.0

DGS (S-PDSO-G10)

PLASTIC SMALL-OUTLINE PACKAGE

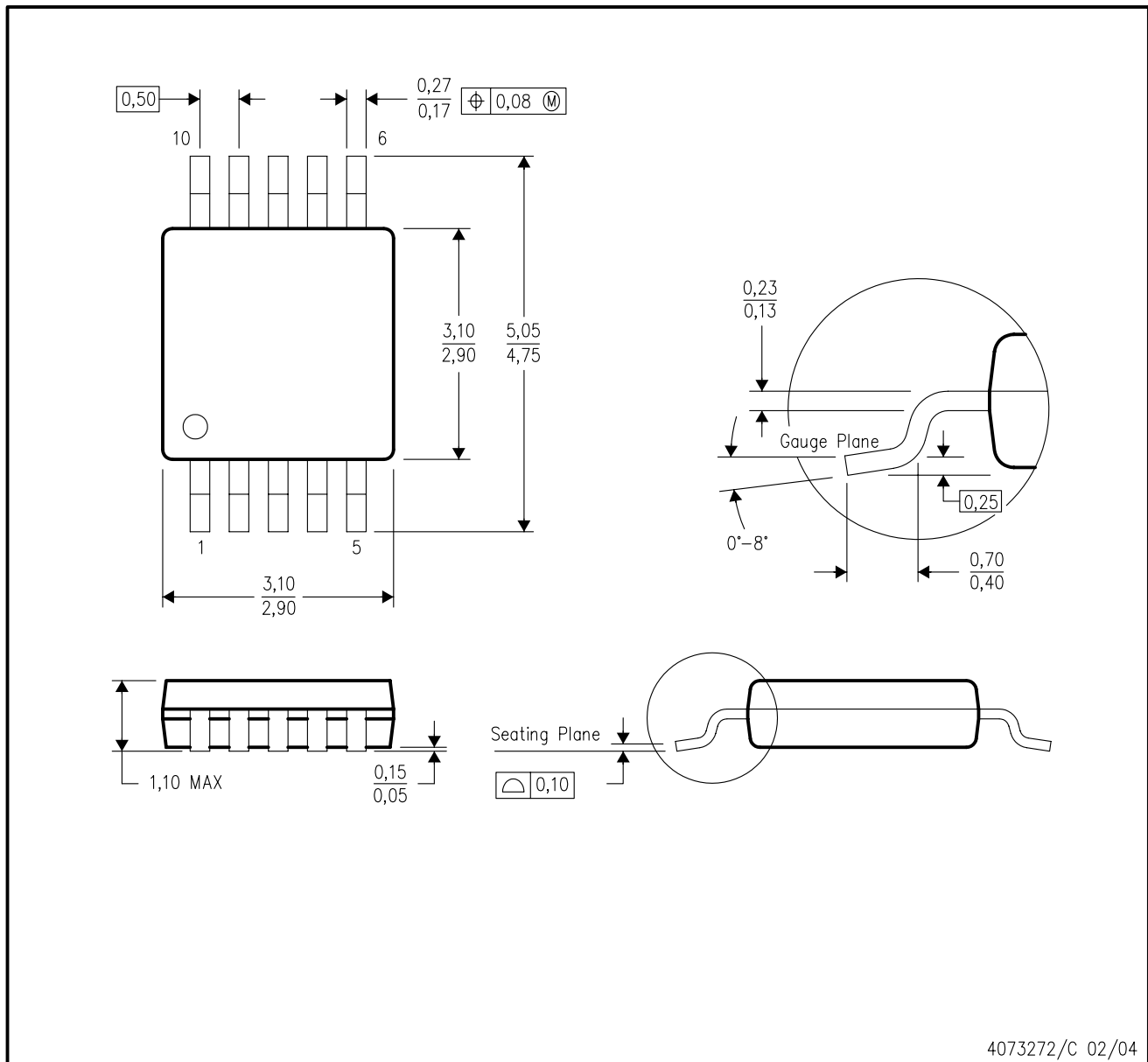

- NOTES:
- A. All linear dimensions are in millimeters.
 - B. This drawing is subject to change without notice.
 - C. Body dimensions do not include mold flash or protrusion.
 - D. Falls within JEDEC MO-187 variation BA.

DGS (S-PDSO-G10)

PLASTIC SMALL OUTLINE PACKAGE

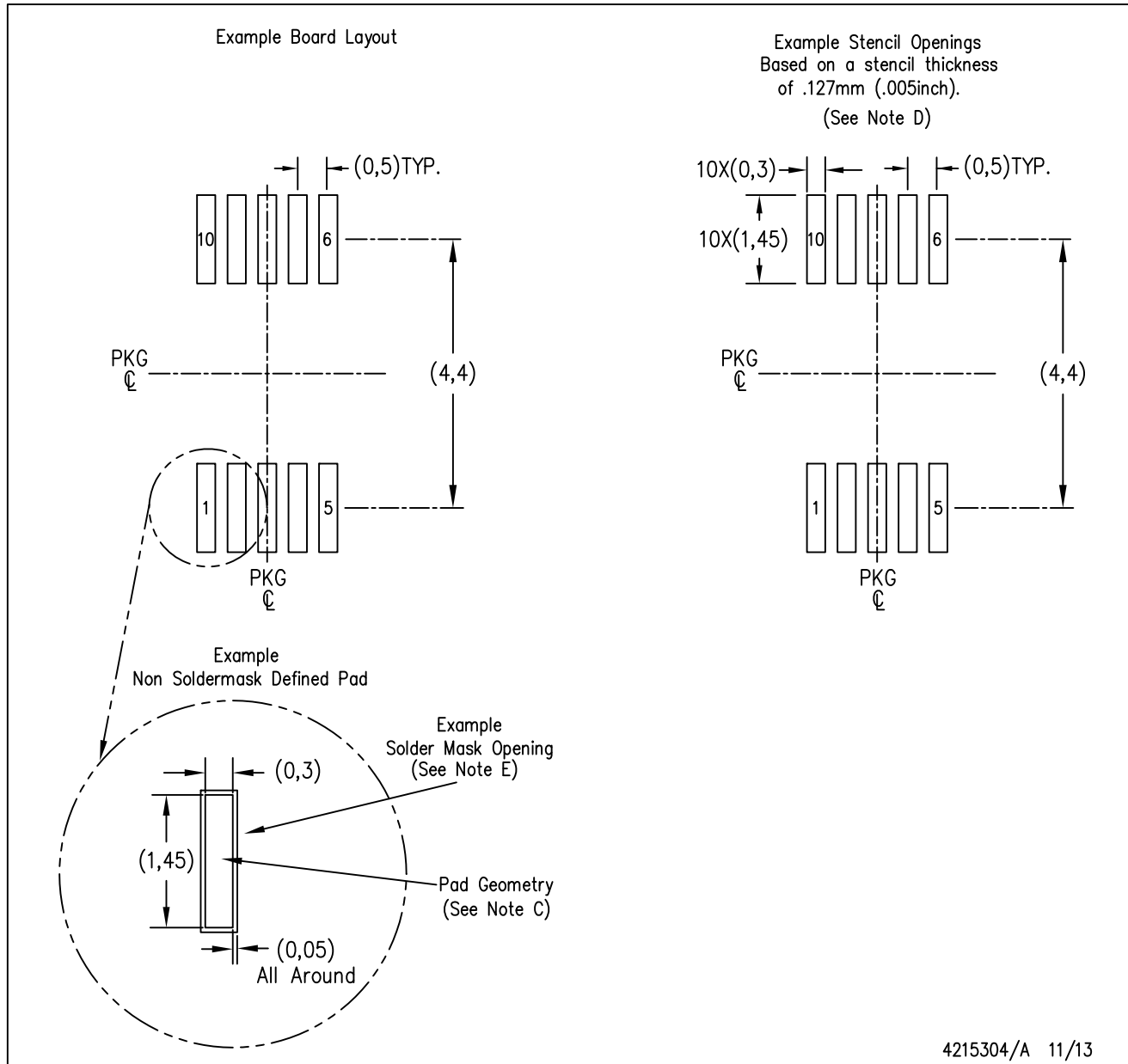

- NOTES:
- All linear dimensions are in millimeters.
 - This drawing is subject to change without notice.
 - Publication IPC-7351 is recommended for alternate designs.
 - Laser cutting apertures with trapezoidal walls and also rounding corners will offer better paste release. Customers should contact their board assembly site for stencil design recommendations. Refer to IPC-7525 for other stencil recommendations.
 - Customers should contact their board fabrication site for solder mask tolerances between and around signal pads.

RSE (R-PUQFN-N10)

PLASTIC QUAD FLATPACK NO-LEAD

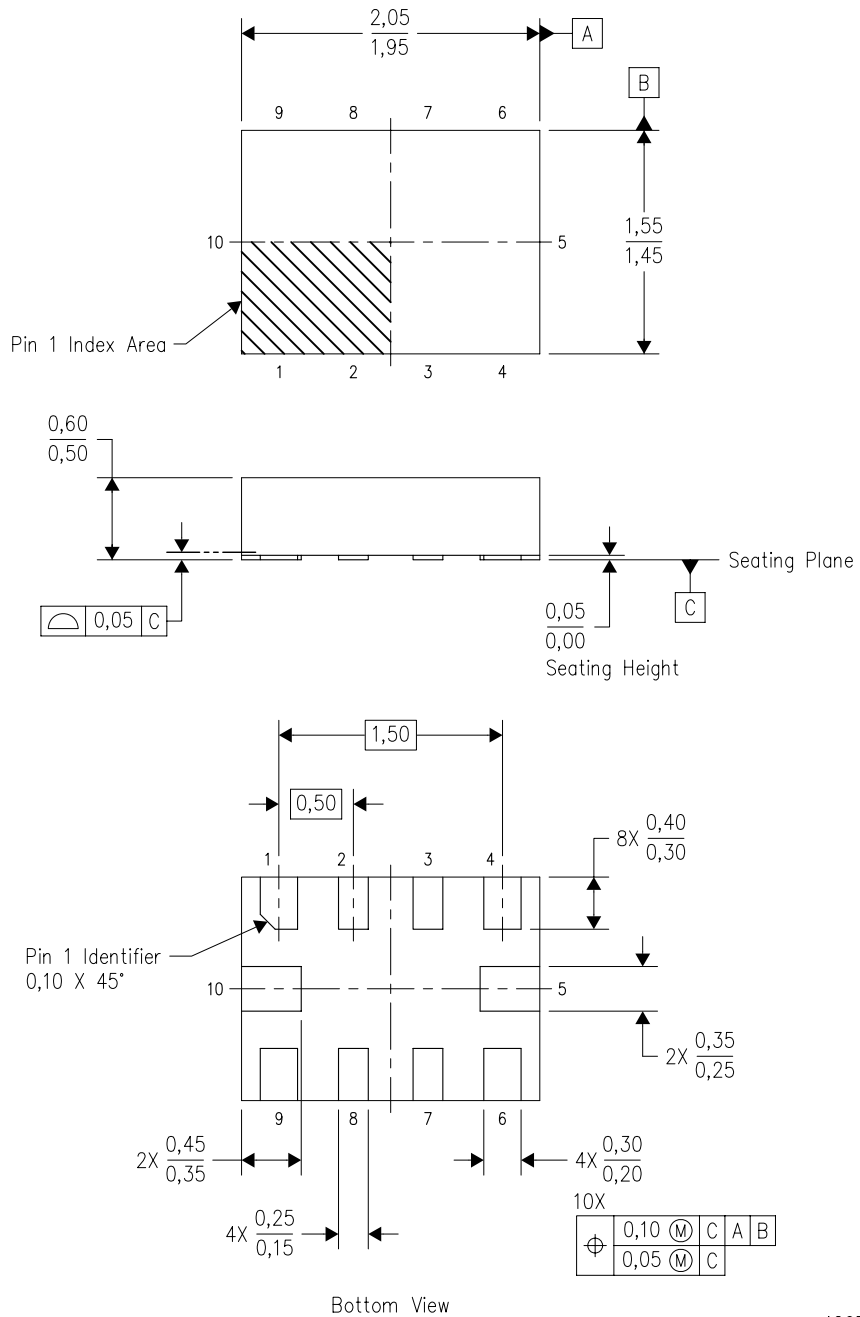

4207268-3/D 01/11

- NOTES:
- All linear dimensions are in millimeters. Dimensioning and tolerancing per ASME Y14.5M-1994.
 - This drawing is subject to change without notice.
 - QFN (Quad Flatpack No-Lead) package configuration.
 - This package complies to JEDEC MO-288 variation UDFD.

RSE (R-PUQFN-N10)

PLASTIC QUAD FLATPACK NO-LEAD

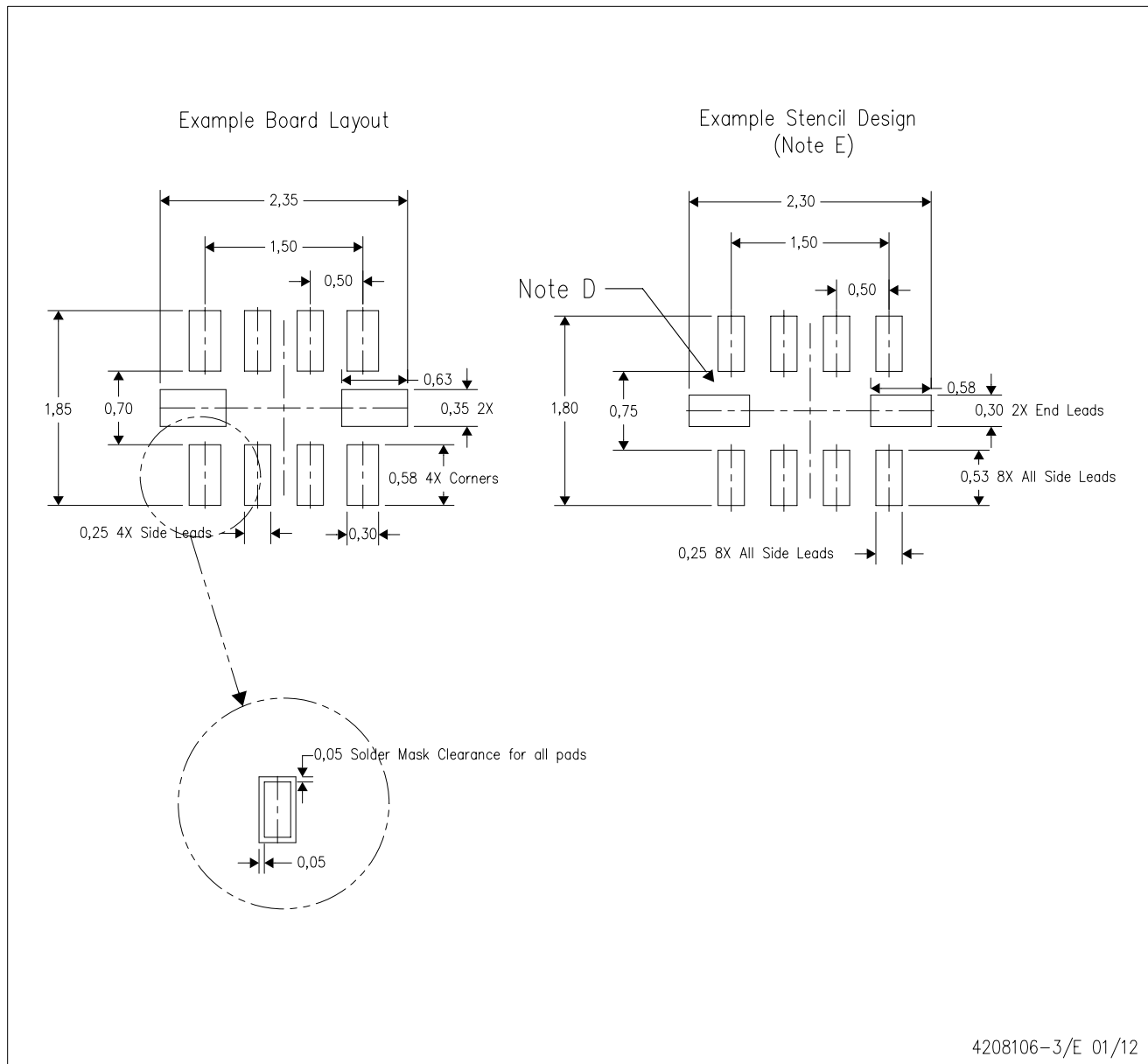

- NOTES:
- A. All linear dimensions are in millimeters.
 - B. This drawing is subject to change without notice.
 - C. Publication IPC-7351 is recommended for alternate designs.
 - D. Customers should contact their board fabrication site for minimum solder mask web tolerances between signal pads.
 - E. Maximum stencil thickness 0,127 mm (5 mils). All linear dimensions are in millimeters.
 - F. Laser cutting apertures with trapezoidal walls and also rounding corners will offer better paste release. Customers should contact their board assembly site for stencil design recommendations. Refer to IPC 7525 for stencil design considerations.
 - G. Side aperture dimensions over-print land for acceptable area ratio > 0.66. Customer may reduce side aperture dimensions if stencil manufacturing process allows for sufficient release at smaller opening.

IMPORTANT NOTICE

Texas Instruments Incorporated and its subsidiaries (TI) reserve the right to make corrections, enhancements, improvements and other changes to its semiconductor products and services per JESD46, latest issue, and to discontinue any product or service per JESD48, latest issue. Buyers should obtain the latest relevant information before placing orders and should verify that such information is current and complete. All semiconductor products (also referred to herein as "components") are sold subject to TI's terms and conditions of sale supplied at the time of order acknowledgment.

TI warrants performance of its components to the specifications applicable at the time of sale, in accordance with the warranty in TI's terms and conditions of sale of semiconductor products. Testing and other quality control techniques are used to the extent TI deems necessary to support this warranty. Except where mandated by applicable law, testing of all parameters of each component is not necessarily performed.

TI assumes no liability for applications assistance or the design of Buyers' products. Buyers are responsible for their products and applications using TI components. To minimize the risks associated with Buyers' products and applications, Buyers should provide adequate design and operating safeguards.

TI does not warrant or represent that any license, either express or implied, is granted under any patent right, copyright, mask work right, or other intellectual property right relating to any combination, machine, or process in which TI components or services are used. Information published by TI regarding third-party products or services does not constitute a license to use such products or services or a warranty or endorsement thereof. Use of such information may require a license from a third party under the patents or other intellectual property of the third party, or a license from TI under the patents or other intellectual property of TI.

Reproduction of significant portions of TI information in TI data books or data sheets is permissible only if reproduction is without alteration and is accompanied by all associated warranties, conditions, limitations, and notices. TI is not responsible or liable for such altered documentation. Information of third parties may be subject to additional restrictions.

Resale of TI components or services with statements different from or beyond the parameters stated by TI for that component or service voids all express and any implied warranties for the associated TI component or service and is an unfair and deceptive business practice. TI is not responsible or liable for any such statements.

Buyer acknowledges and agrees that it is solely responsible for compliance with all legal, regulatory and safety-related requirements concerning its products, and any use of TI components in its applications, notwithstanding any applications-related information or support that may be provided by TI. Buyer represents and agrees that it has all the necessary expertise to create and implement safeguards which anticipate dangerous consequences of failures, monitor failures and their consequences, lessen the likelihood of failures that might cause harm and take appropriate remedial actions. Buyer will fully indemnify TI and its representatives against any damages arising out of the use of any TI components in safety-critical applications.

In some cases, TI components may be promoted specifically to facilitate safety-related applications. With such components, TI's goal is to help enable customers to design and create their own end-product solutions that meet applicable functional safety standards and requirements. Nonetheless, such components are subject to these terms.

No TI components are authorized for use in FDA Class III (or similar life-critical medical equipment) unless authorized officers of the parties have executed a special agreement specifically governing such use.

Only those TI components which TI has specifically designated as military grade or "enhanced plastic" are designed and intended for use in military/aerospace applications or environments. Buyer acknowledges and agrees that any military or aerospace use of TI components which have **not** been so designated is solely at the Buyer's risk, and that Buyer is solely responsible for compliance with all legal and regulatory requirements in connection with such use.

TI has specifically designated certain components as meeting ISO/TS16949 requirements, mainly for automotive use. In any case of use of non-designated products, TI will not be responsible for any failure to meet ISO/TS16949.

Products

Audio	www.ti.com/audio
Amplifiers	amplifier.ti.com
Data Converters	dataconverter.ti.com
DLP® Products	www.dlp.com
DSP	dsp.ti.com
Clocks and Timers	www.ti.com/clocks
Interface	interface.ti.com
Logic	logic.ti.com
Power Mgmt	power.ti.com
Microcontrollers	microcontroller.ti.com
RFID	www.ti-rfid.com
OMAP Applications Processors	www.ti.com/omap
Wireless Connectivity	www.ti.com/wirelessconnectivity

Applications

Automotive and Transportation	www.ti.com/automotive
Communications and Telecom	www.ti.com/communications
Computers and Peripherals	www.ti.com/computers
Consumer Electronics	www.ti.com/consumer-apps
Energy and Lighting	www.ti.com/energy
Industrial	www.ti.com/industrial
Medical	www.ti.com/medical
Security	www.ti.com/security
Space, Avionics and Defense	www.ti.com/space-avionics-defense
Video and Imaging	www.ti.com/video

TI E2E Community

e2e.ti.com