

0.7-Ω DUAL SPDT ANALOG SWITCH WITH NEGATIVE RAIL CAPABILITY AND 1.8-V COMPATIBLE INPUT LOGIC

Check for Samples: [TS5A22366](#)

FEATURES

- **Negative Signaling Capability:** Maximum Swing From -2.75 V to 2.75 V ($V_+ = 2.75\text{ V}$)
- **Low ON-State Resistance ($0.7\ \Omega$ Typ)**
- **Excellent ON-State Resistance Matching**
- **1.8-V Compatible Control Input Threshold Independent of V_+**
- **Control Inputs Are 5.5-V Tolerant**
- **2.25-V to 5.5-V Power Supply (V_+)**
- **Low Charge Injection**
- **Specified Break-Before-Make Switching**
- **Latch-Up Performance Exceeds 100 mA Per JESD 78, Class II**

- **ESD Performance Tested Per JESD 22**
 - 2500-V Human-Body Model (A114-B, Class II)
 - 1000-V Charged-Device Model (C101)
 - 200-V Machine Model (A115-A)

APPLICATIONS

- Cell Phones
- PDAs
- Portable Instrumentation
- Audio Routing
- Portable Media Players

YFC PACKAGE TERMINAL ASSIGNMENTS

D	NC1	V_+	NC2
C	COM1	GND	COM2
B	NO1	GND	NO2
A	IN1	N.C. ⁽¹⁾	IN2
	1	2	3

YFC PACKAGE

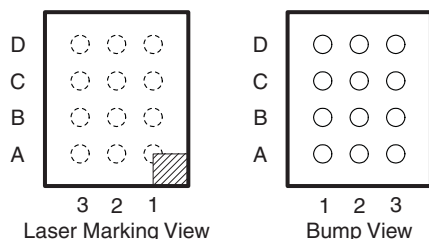

(1) N.C. –No internal connection

DESCRIPTION

The TS5A22366 is a dual single-pole double-throw (SPDT) analog switch that is designed to operate from 2.25 V to 5.5 V. The device features negative signal capability that allows signals below ground to pass through the switch without distortion.

The break-before-make feature prevents signal distortion during the transferring of a signal from one path to another. Low ON-state resistance, excellent channel-to-channel ON-state resistance matching, and minimal total harmonic distortion (THD) performance are ideal for audio applications.

The TS5A22366 is available as a ultra small 1.6 mm × 1.2 mm wafer-chip-scale package (WCSP) (0.4 mm pitch).

ORDERING INFORMATION

For package and ordering information, see the Package Option Addendum at the end of this document.



Please be aware that an important notice concerning availability, standard warranty, and use in critical applications of Texas Instruments semiconductor products and disclaimers thereto appears at the end of this data sheet.

Table 1. SUMMARY OF CHARACTERISTICS $V_+ = 3.3\text{ V}$, $T_A = 25^\circ\text{C}$

Configuration	2:1 Multiplexer/Demultiplexer (2 × SPDT)
Number of channels	2
ON-state resistance (r_{on})	0.8 Ω
ON-state resistance match (Δr_{on})	0.08 Ω
ON-state resistance flatness ($r_{ON(flat)}$)	0.3 Ω
Turn-on/turn-off time (t_{ON}/t_{OFF})	199 ns/182 ns
Break-before-make time (t_{BBM})	7.1 ns
Charge injection (Q_C)	120 pC
Bandwidth (BW)	32 MHz
OFF isolation (O_{ISO})	-70 dB at 100 kHz
Crosstalk (X_{TALK})	-70 dB at 100 kHz
Total harmonic distortion (THD)	0.01%
Package option	12-pin WCSP (YFC)

Table 2. FUNCTION TABLE

IN	NC TO COM, COM TO NC	NO TO COM, COM TO NO
L	ON	OFF
H	OFF	ON

APPLICATION BLOCK DIAGRAM

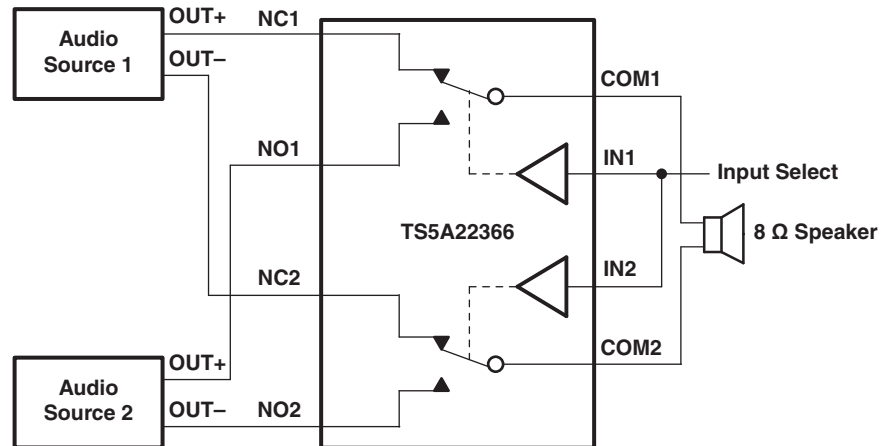

Figure 1. TS5A22366 Application Block Diagram

Negative Signaling Capacity

The TS5A22366 dual SPDT switch features negative signal capability that allows signals below ground to pass through without distortion. These analog switches operate from a single +2.3-V to +5.5-V supply. The input/output signal swing of the device is dependant of the supply voltage V_+ : the devices pass signals as high as V_+ and as low as $V_+ - 5.5$ V, including signals below ground with minimal distortion.

Table 3 shows the input/output signal swing the user can get with different supply voltages.

Table 3. Input/Output Signal Swing

SUPPLY VOLTAGE, V_+	MINIMUM (V_{NC}, V_{NO}, V_{COM}) = $V_+ - 5.5$	MAXIMUM (V_{NC}, V_{NO}, V_{COM}) = V_+
5.5 V	0 V	5.5 V
4.2 V	-1.3 V	4.2 V
3.3 V	-2.2 V	3.3 V
3 V	-2.5 V	3 V
2.5 V	-3 V	2.5 V

ABSOLUTE MINIMUM AND MAXIMUM RATINGS^{(1) (2)}

over operating free-air temperature range (unless otherwise noted)

		MIN	MAX	UNIT		
V_+	Supply voltage range ⁽³⁾	-0.5	6	V		
V_{NC} V_{NO} V_{COM}	Analog voltage range ^{(3) (4) (5)}	$V_+ - 6$	$V_+ + 0.5$	V		
I_K	Analog port diode current ⁽⁶⁾	$V_+ < V_{NC}, V_{NO}, V_{COM} < 0$		V		
I_{NC} I_{NO} I_{COM}	ON-state switch current	$V_{NC}, V_{NO}, V_{COM} = 0 \text{ to } V_+$		-150	150	mA
	ON-state peak switch current ⁽⁷⁾			-300	300	
V_I	Digital input voltage range	-0.5	6.5	V		
I_{IK}	Digital input clamp current ^{(3) (4)}	$V_{IO} < V_I < 0$		-50		mA
I_{GND} I_+	Continuous current through V_+ or GND	-100	100			mA
T_{stg}	Storage temperature range	-65	150			°C

- (1) Stresses above these ratings may cause permanent damage. Exposure to absolute maximum conditions for extended periods may degrade device reliability. These are stress ratings only, and functional operation of the device at these or any other conditions beyond those specified is not implied.
- (2) The algebraic convention, whereby the most negative value is a minimum and the most positive value is a maximum
- (3) All voltages are with respect to ground, unless otherwise specified.
- (4) The input and output voltage ratings may be exceeded if the input and output clamp-current ratings are observed.
- (5) This value is limited to 5.5 V maximum.
- (6) Requires clamp diodes on analog port to V_+ .
- (7) Pulse at 1-ms duration <10% duty cycle

THERMAL IMPEDANCE RATINGS

			UNIT	
θ_{JA}	Package thermal impedance ⁽¹⁾	YFC package	106.2	°C/W

- (1) The package thermal impedance is calculated in accordance with JESD 51-7.

ELECTRICAL CHARACTERISTICS FOR 2.5-V SUPPLY⁽¹⁾
 $V_+ = 2.25\text{ V to }2.7\text{ V}$, $T_A = -40^\circ\text{C to }85^\circ\text{C}$ (unless otherwise noted)

PARAMETER	SYMBOL	TEST CONDITIONS	T_A	V_+	MIN	TYP	MAX	UNIT
Analog Switch								
Analog signal range	V_{COM}, V_{NO}, V_{NC}				$V_+ - 5.5$		V_+	Ω
ON-state resistance	r_{on}	V_{NC} or $V_{NO} = V_+, 1.5\text{ V}$, $V_+ - 5.5\text{ V}$ $I_{COM} = -100\text{ mA}$, Switch ON, See Figure 15	25°C	2.25 V		1	1.8	Ω
			Full				2	
ON-state resistance match between channels	Δr_{on}	V_{NC} or $V_{NO} = 1.5\text{ V}$, $I_{COM} = -100\text{ mA}$, Switch ON, See Figure 15	25°C	2.25 V		0.05	1	Ω
			Full				1	
ON-state resistance flatness	$r_{on(flat)}$	V_{NC} or $V_{NO} = V_+, 1.5\text{ V}$, $V_+ - 5.5\text{ V}$ $I_{COM} = -100\text{ mA}$, Switch ON, See Figure 16	25°C	2.25 V		0.53	1.5	Ω
			Full				1.6	
NC, NO OFF leakage current	$I_{NC(OFF)}, I_{NO(OFF)}$	$V_{NC} = 2.25, V_+ - 5.5\text{ V}$ $V_{COM} = V_+ - 5.5\text{ V}, 2.25,$ $V_{NO} = \text{Open}$, or $V_{NO} = 2.25, V_+ - 5.5\text{ V}$ $V_{COM} = V_+ - 5.5\text{ V}, 2.25,$ $V_{NC} = \text{Open}$, Switch OFF, See Figure 16	25°C	2.7 V	-50		50	nA
			Full			-375		
COM ON leakage current	$I_{COM(ON)}$	V_{NC} and $V_{NO} = \text{Open}$, $V_{COM} = V_+, V_+ - 5.5\text{ V}$, See Figure 17	25°C	2.7 V	-50		50	nA
			Full			-375		
Digital Control Inputs (IN, EN)⁽²⁾								
Input logic high	V_{IH}		Full		1.05		5.5	V
Input logic low	V_{IL}		Full				0.65	V
Input leakage current	I_{IH}, I_{IL}	$V_{IN} = 1.8\text{ V or GND}$	25°C	2.7 V	-700		700	nA
			Full			-700		

(1) The algebraic convention, whereby the most negative value is a minimum and the most positive value is a maximum

(2) All unused digital inputs of the device must be held at V_+ or GND to ensure proper device operation. Refer to the TI application report, *Implications of Slow or Floating CMOS Inputs*, literature number SCBA004.

ELECTRICAL CHARACTERISTICS FOR 2.5-V SUPPLY⁽¹⁾ (continued)
 $V_+ = 2.25\text{ V to }2.7\text{ V}$, $T_A = -40^\circ\text{C to }85^\circ\text{C}$ (unless otherwise noted)

PARAMETER	SYMBOL	TEST CONDITIONS		T_A	V_+	MIN	TYP	MAX	UNIT
Dynamic									
Turn-on time	t_{ON}	$V_{COM} = V_+$, $R_L = 300\ \Omega$,	$C_L = 35\text{ pF}$, See Figure 19	25°C	2.5 V		193	297	ns
				Full	2.25 V to 2.7 V			350	
Turn-off time	t_{OFF}	$V_{COM} = V_+$, $R_L = 300\ \Omega$,	$C_L = 35\text{ pF}$, See Figure 19	25°C	2.5 V			266	ns
				Full	2.25 V to 2.7 V			320	
Break-before-make time	t_{BBM}	$V_{NC} = V_{NO} = V_+/2$ $R_L = 300\ \Omega$,	$C_L = 35\text{ pF}$, See Figure 20	25°C	2.5 V	1	15.6		ns
Charge injection	Q_C	$V_{GEN} = 0$, $R_{GEN} = 0$,	$C_L = 1\text{ nF}$, See Figure 24	25°C	2.5 V		91		pC
NC, NO OFF capacitance	$C_{NC(OFF)}$, $C_{NO(OFF)}$	V_{NC} or $V_{NO} = V_+$ or GND, Switch OFF,	See Figure 18	25°C	2.5 V		51		pF
NC, NO ON capacitance	$C_{NC(ON)}$, $C_{NO(ON)}$	V_{NC} or $V_{NO} = V_+$ or GND, Switch OFF,	See Figure 18	25°C	2.5 V		181		pF
COM ON capacitance	$C_{COM(ON)}$	$V_{COM} = V_+$ or GND, Switch ON,	See Figure 18	25°C	2.5 V		181		pF
Digital input capacitance	C_I	$V_I = V_+$ or GND	See Figure 18	25°C	2.5 V		3		pF
Bandwidth	BW	$R_L = 50\ \Omega$,	Switch ON, See Figure 20	25°C	2.5 V		32		MHz
OFF isolation	O_{ISO}	$R_L = 50\ \Omega$, Switch OFF, See Figure 22	$f = 100\text{ kHz}$,	25°C	2.5 V		-70		dB
			$f = 1\text{ MHz}$,				-50		
			$f = 5\text{ MHz}$,				-35		
Crosstalk	X_{TALK}	$R_L = 50\ \Omega$, Switch ON, See Figure 23	$f = 100\text{ kHz}$,	25°C	2.5 V		-70		dB
			$f = 1\text{ MHz}$,				-50		
			$f = 5\text{ MHz}$,				-35		
Total harmonic distortion	THD	$R_L = 600\ \Omega$, $C_L = 50\text{ pF}$,	$f = 20\text{ Hz to }20\text{ kHz}$, See Figure 25	25°C	2.5 V		0.02		%
Supply									
Positive supply current	I_+	$V_I = 1.8\text{ V or GND}$,		Full	2.7 V		6	12	μA

ELECTRICAL CHARACTERISTICS FOR 3.3-V SUPPLY⁽¹⁾
 $V_+ = 3\text{ V to }3.6\text{ V}$, $T_A = -40^\circ\text{C to }85^\circ\text{C}$ (unless otherwise noted)

PARAMETER	SYMBOL	TEST CONDITIONS	T_A	V_+	MIN	TYP	MAX	UNIT
Analog Switch								
Analog signal range	V_{COM}, V_{NO}, V_{NC}				$V_+ - 5.5$		V_+	Ω
ON-state resistance	r_{on}	V_{NC} or $V_{NO} \leq V_+, 1.5\text{ V}$, $V_+ - 5.5\text{ V}$, $I_{COM} = -100\text{ mA}$, Switch ON, See Figure 15	25°C Full	3 V		0.8 1.3		Ω
ON-state resistance match between channels	Δr_{on}	V_{NC} or $V_{NO} = 1.5\text{ V}$, $I_{COM} = -100\text{ mA}$, Switch ON, See Figure 15	25°C Full	3 V		0.08 0.17		Ω
ON-state resistance flatness	$r_{on(flat)}$	V_{NC} or $V_{NO} \leq V_+, 1.5\text{ V}$, $V_+ - 5.5\text{ V}$, $I_{COM} = -100\text{ mA}$, Switch ON, See Figure 16	25°C Full	3 V		0.3 0.65		Ω
NC, NO OFF leakage current	$I_{NC(OFF)}, I_{NO(OFF)}$	$V_{NC} = 3, V_+ - 5.5\text{ V}$ $V_{COM} = V_+ - 5.5\text{ V}, 3,$ $V_{NO} = \text{Open}$, or $V_{NO} = 3, V_+ - 5.5\text{ V}$ $V_{COM} = V_+ - 5.5\text{ V}, 3,$ $V_{NC} = \text{Open}$, Switch OFF, See Figure 16	25°C Full	3.6 V	-50 -375		50 375	nA
COM ON leakage current	$I_{COM(ON)}$	V_{NC} and $V_{NO} = \text{Open}$, $V_{COM} = V_+, V_+ - 5.5\text{ V}$, Switch ON, See Figure 17	25°C Full	3.6 V	-50 -375		50 375	nA
Digital Control Inputs (IN, EN)⁽²⁾								
Input logic high	V_{IH}		Full		1.05		5.5	V
Input logic low	V_{IL}		Full				0.65	V
Input leakage current	I_{IH}, I_{IL}	$V_{IN} = 1.8\text{ V or GND}$	25°C Full	3.6 V	-920 -920		920 920	nA

(1) The algebraic convention, whereby the most negative value is a minimum and the most positive value is a maximum

(2) All unused digital inputs of the device must be held at V_+ or GND to ensure proper device operation. Refer to the TI application report, *Implications of Slow or Floating CMOS Inputs*, literature number SCBA004.

ELECTRICAL CHARACTERISTICS FOR 3.3-V SUPPLY⁽¹⁾ (continued)
 $V_+ = 3\text{ V to }3.6\text{ V}$, $T_A = -40^\circ\text{C to }85^\circ\text{C}$ (unless otherwise noted)

PARAMETER	SYMBOL	TEST CONDITIONS	T_A	V_+	MIN	TYP	MAX	UNIT
Dynamic								
Turn-on time	t_{ON}	$V_{COM} = V_+$, $R_L = 300\ \Omega$,	$C_L = 35\ \text{pF}$, See Figure 19	25°C	3.3 V	199	313	ns
				Full	3 V to 3.6 V		370	
Turn-off time	t_{OFF}	$V_{COM} = V_+$, $R_L = 300\ \Omega$,	$C_L = 35\ \text{pF}$, See Figure 19	25°C	3.3 V	182	289.9	ns
				Full	3 V to 3.6 V		350	
Break-before-make time	t_{BBM}	$V_{NC} = V_{NO} = V_+/2$ $R_L = 300\ \Omega$,	$C_L = 35\ \text{pF}$, See Figure 20	25°C	3.3 V	1	7.1	ns
Charge injection	Q_C	$V_{GEN} = 0$, $R_{GEN} = 0$,	$C_L = 1\ \text{nF}$, See Figure 24	25°C	3.3 V		120	pC
NC, NO OFF capacitance	$C_{NC(OFF)}$, $C_{NO(OFF)}$	V_{NC} or $V_{NO} = V_+$ or $V_+ - 5.5\ \text{V}$, Switch OFF,	See Figure 18	25°C	3.3 V		50	pF
NC, NO ON capacitance	$C_{NC(ON)}$, $C_{NO(ON)}$	V_{NC} or $V_{NO} = V_+$ or GND, Switch OFF,	See Figure 18	25°C	3.3 V		180	pF
COM ON capacitance	$C_{COM(ON)}$	$V_{COM} = V_+$ or GND, Switch ON,	See Figure 18	25°C	3.3 V		180	pF
Digital input capacitance	C_I	$V_I = V_+$ or GND	See Figure 18	25°C	3.3 V		3	pF
Bandwidth	BW	$R_L = 50\ \Omega$,	Switch ON, See Figure 20	25°C	3.3 V		32	MHz
OFF isolation	O_{ISO}	$R_L = 50\ \Omega$, Switch OFF, See Figure 22	$f = 100\ \text{kHz}$, $f = 1\ \text{MHz}$, $f = 5\ \text{MHz}$,	25°C	3.3 V		-70	dB
							-50	
							-35	
Crosstalk	X_{TALK}	$R_L = 50\ \Omega$, Switch ON, See Figure 23	$f = 100\ \text{kHz}$, $f = 1\ \text{MHz}$, $f = 5\ \text{MHz}$,	25°C	3.3 V		-70	dB
							-50	
							-35	
Total harmonic distortion	THD	$R_L = 600\ \Omega$, $C_L = 50\ \text{pF}$,	$f = 20\ \text{Hz to }20\ \text{kHz}$, See Figure 25	25°C	3.3 V		0.01	%
Supply								
Positive supply current	I_+	$V_I = 1.8\ \text{V}$ or GND		Full	3.6 V		6 13	μA

ELECTRICAL CHARACTERISTICS FOR 5-V SUPPLY⁽¹⁾
 $V_+ = 4.5\text{ V to }5.5\text{ V}$, $T_A = -40^\circ\text{C to }85^\circ\text{C}$ (unless otherwise noted)

PARAMETER	SYMBOL	TEST CONDITIONS	T_A	V_+	MIN	TYP	MAX	UNIT
Analog Switch								
Analog signal range	V_{COM}, V_{NO}, V_{NC}				$V_+ - 5.5$		V_+	Ω
ON-state resistance	r_{on}	V_{NC} or $V_{NO} = V_+, 1.5\text{V}, V_+ - 5.5\text{V}$ $I_{COM} = -100\text{ mA}$,	Switch ON, See Figure 15	25°C Full	4.5 V	0.7	1 1.36	Ω
ON-state resistance match between channels	Δr_{on}	V_{NC} or $V_{NO} = 1.5\text{ V}$, $I_{COM} = -100\text{ mA}$,	Switch ON, See Figure 15	25°C Full	4.5 V	0.1	0.2 0.3	Ω
ON-state resistance flatness	$r_{on(flat)}$	V_{NC} or $V_{NO} = V_+, 1.5\text{V}, V_+ - 5.5\text{V}$ $I_{COM} = -100\text{ mA}$,	Switch ON, See Figure 16	25°C Full	4.5 V	0.135	0.37 0.51	Ω
NC, NO OFF leakage current	$I_{NC(OFF)}, I_{NO(OFF)}$	$V_{NC} = 4.5, V_+ - 5.5\text{ V}$ $V_{COM} = V_+ - 5.5\text{ V}, 4.5,$ $V_{NO} = \text{Open},$ or $V_{NO} = 4.5, V_+ - 5.5\text{ V}$ $V_{COM} = V_+ - 5.5\text{ V}, 4.5,$ $V_{NC} = \text{Open},$	Switch OFF, See Figure 16	25°C Full	5.5 V	-50	50 375	nA
COM ON leakage current	$I_{COM(ON)}$	V_{NC} and $V_{NO} = \text{Open},$ $V_{COM} = V_+, V_+ - 5.5\text{ V},$	Switch ON, See Figure 17	25°C Full	5.5 V	-50	50 375	nA
Digital Control Inputs (IN, EN)⁽²⁾								
Input logic high	V_{IH}			Full		1.05	5.5	V
Input logic low	V_{IL}			Full			0.65	V
Input leakage current	I_{IH}, I_{IL}	$V_{IN} = 1.8\text{ V or }0$		25°C Full	5.5 V	-1.5	1.5 1.5	μA

(1) The algebraic convention, whereby the most negative value is a minimum and the most positive value is a maximum

(2) All unused digital inputs of the device must be held at V_+ or GND to ensure proper device operation. Refer to the TI application report, *Implications of Slow or Floating CMOS Inputs*, literature number SCBA004.

ELECTRICAL CHARACTERISTICS FOR 5-V SUPPLY⁽¹⁾ (continued)
 $V_+ = 4.5 \text{ V to } 5.5 \text{ V}$, $T_A = -40^\circ\text{C to } 85^\circ\text{C}$ (unless otherwise noted)

PARAMETER	SYMBOL	TEST CONDITIONS		T_A	V_+	MIN	TYP	MAX	UNIT
Dynamic									
Turn-on time	t_{ON}	$V_{COM} = V_+$, $R_L = 300 \Omega$,	$C_L = 35 \text{ pF}$, See Figure 19	25°C	5 V		230	374	ns
				Full	4.5 V to 5.5 V			470	
Turn-off time	t_{OFF}	$V_{COM} = V_+$, $R_L = 300 \Omega$,	$C_L = 35 \text{ pF}$, See Figure 19	25°C	5 V		206	325	ns
				Full	4.5 V to 5.5 V			380	
Break-before-make time	t_{BBM}	$V_{NC} = V_{NO} = V_+/2$, $R_L = 300 \Omega$,	$C_L = 35 \text{ pF}$, See Figure 20	25°C	3.3 V	1	3		ns
Charge injection	Q_C	$V_{GEN} = 0$, $R_{GEN} = 0$,	$C_L = 1 \text{ nF}$, See Figure 24	25°C	5 V		168		pC
NC, NO OFF capacitance	$C_{NC(OFF)}$, $C_{NO(OFF)}$	V_{NC} or $V_{NO} = V_+$ or $V_+ - 5.5 \text{ V}$, Switch OFF,	See Figure 18	25°C	5 V		48		pF
NC, NO ON capacitance	$C_{NC(ON)}$, $C_{NO(ON)}$	V_{NC} or $V_{NO} = V_+$ or $V_+ - 5.5 \text{ V}$, Switch ON,	See Figure 18	25°C	5 V		176		pF
COM ON capacitance	$C_{COM(ON)}$	$V_{COM} = V_+$ or GND, Switch ON,	See Figure 18	25°C	5 V		176		pF
Digital input capacitance	C_I	$V_I = V_+$ or GND	See Figure 18	25°C	5 V		3		pF
Bandwidth	BW	$R_L = 50 \Omega$,	Switch ON, See Figure 20	25°C	5 V		32		MHz
OFF isolation	O_{ISO}	$R_L = 50 \Omega$, Switch OFF, See Figure 22	$f = 100 \text{ kHz}$	25°C	5 V		-70		dB
			$f = 1 \text{ MHz}$				-50		
			$f = 5 \text{ MHz}$				-35		
Crosstalk	X_{TALK}	$R_L = 50 \Omega$, Switch ON, See Figure 23	$f = 100 \text{ kHz}$	25°C	5 V		-70		dB
			$f = 1 \text{ MHz}$				-50		
			$f = 5 \text{ MHz}$				-35		
Total harmonic distortion	THD	$R_L = 600 \Omega$, $C_L = 50 \text{ pF}$,	$f = 20 \text{ Hz to } 20 \text{ kHz}$, See Figure 25	25°C	5 V		0.01		%
Supply									
Positive supply current	I_+	$V_I = 1.8 \text{ V or GND}$		Full	5.5 V		7	14	μA

TYPICAL PERFORMANCE

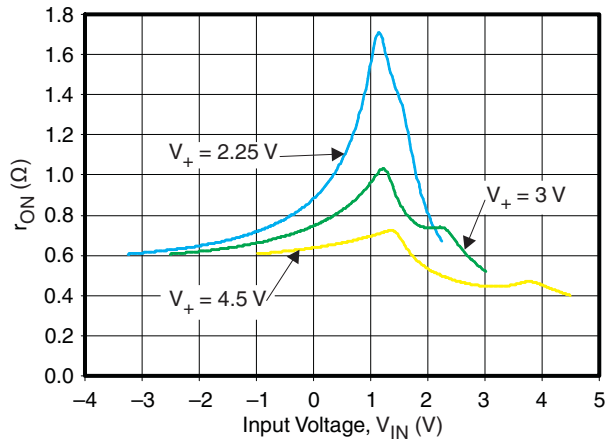

Figure 2. r_{on} vs V_{IN}

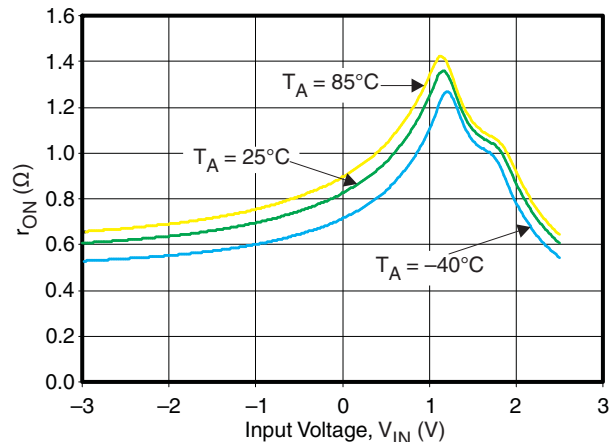

Figure 3. r_{on} vs V_{IN} ($V_+ = 2.5$ V)

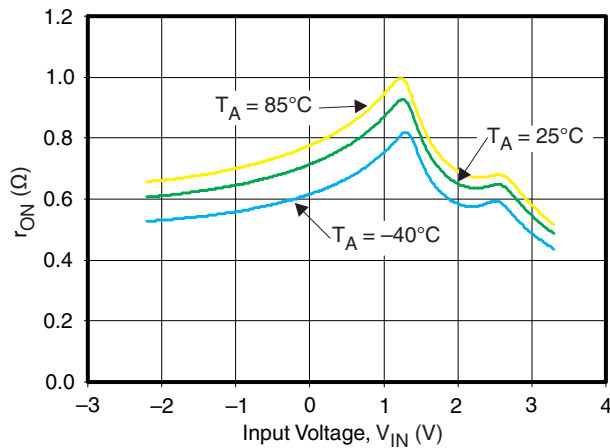

Figure 4. r_{on} vs V_{IN} ($V_+ = 3.3$ V)

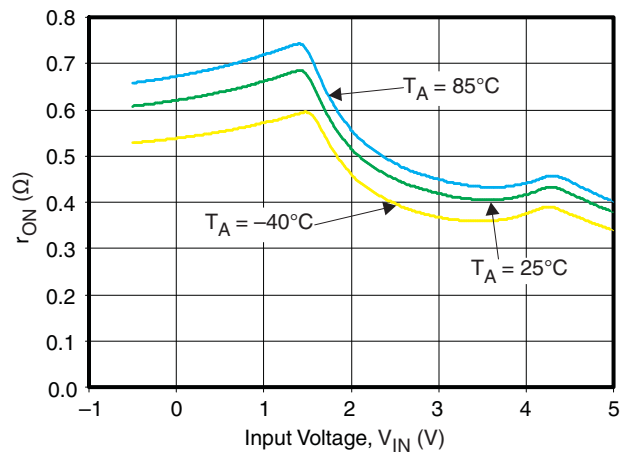

Figure 5. r_{on} vs V_{IN} ($V_+ = 5$ V)

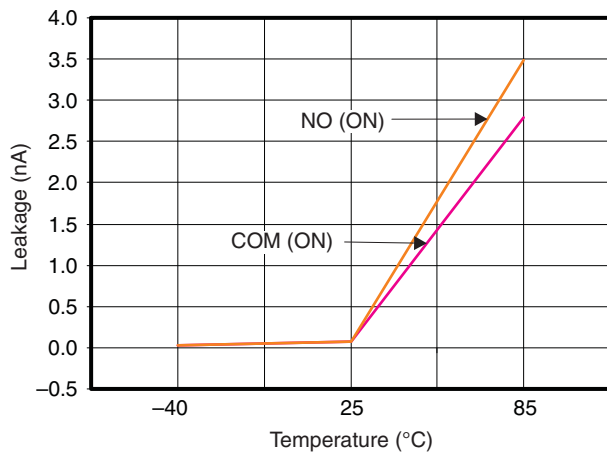

Figure 6. Leakage Current vs Temperature

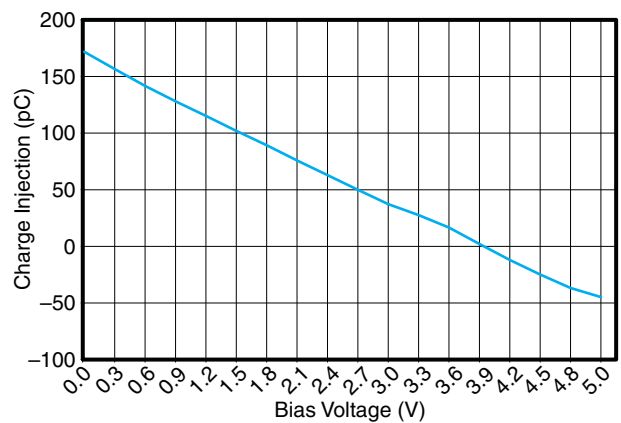

Figure 7. Charge Injection (Q_C) vs V_{COM} ($V_+ = 5$ V)

TYPICAL PERFORMANCE (continued)

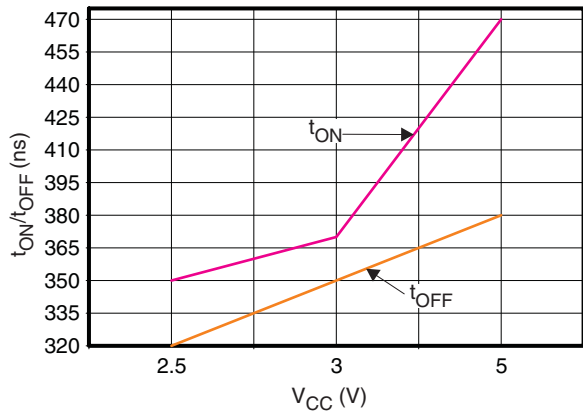

Figure 8. t_{ON} and t_{OFF} vs Supply Voltage

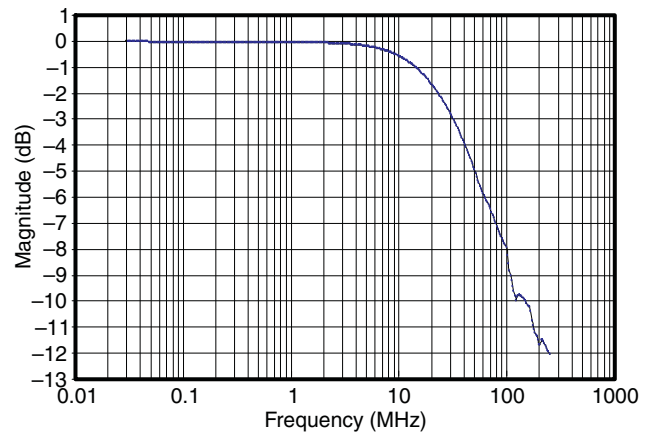

Figure 9. Bandwidth ($V_+ = 2.5\text{ V}$)

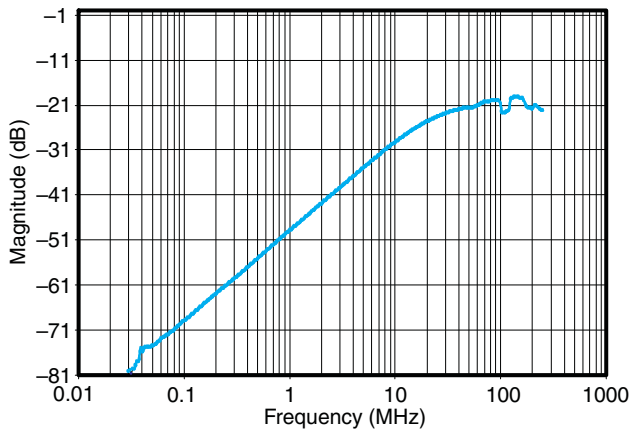

Figure 10. OFF Isolation vs Frequency

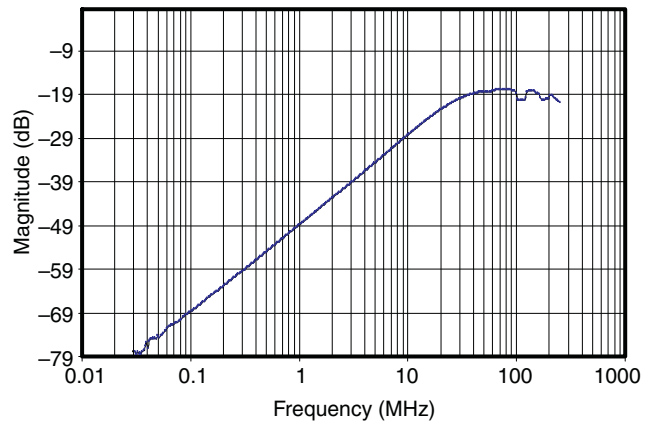

Figure 11. Crosstalk ($V_+ = 3.3\text{ V}$)

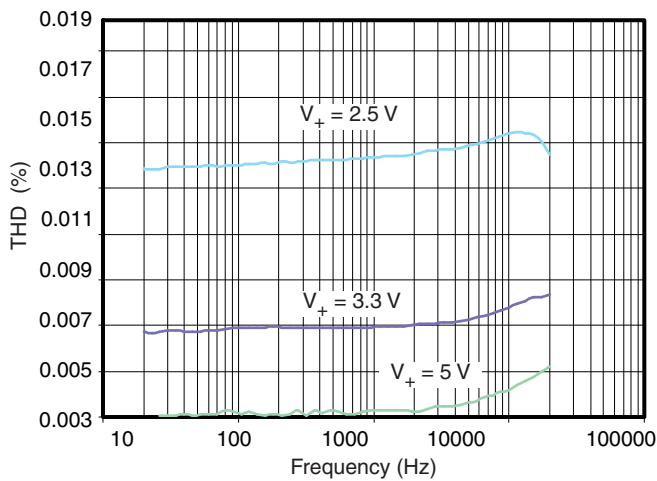

Figure 12. Total Harmonic Distortion vs Frequency

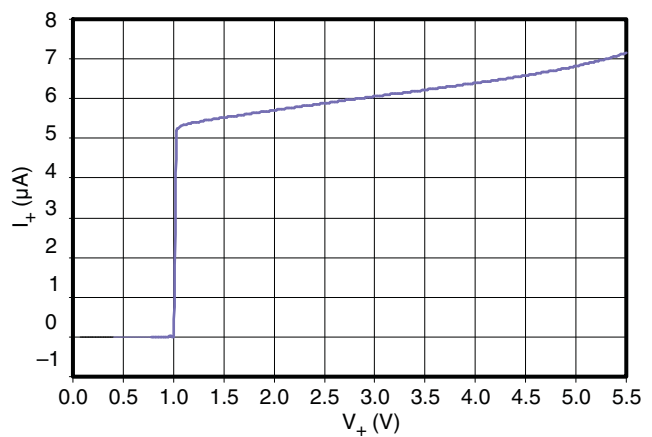

Figure 13. Power-Supply Current vs V_+

TYPICAL PERFORMANCE (continued)

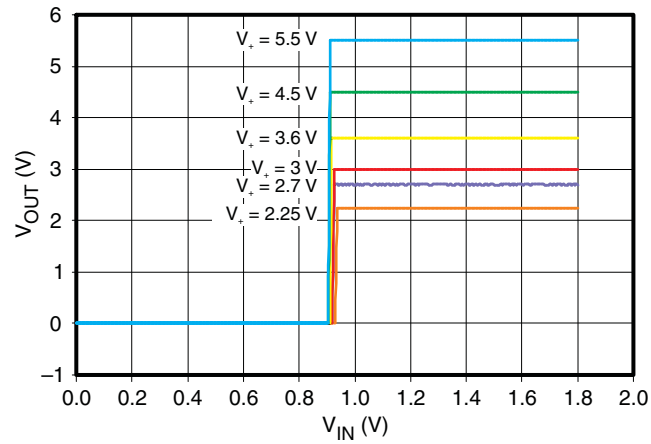

Figure 14. Control Input Thresholds

PARAMETER MEASUREMENT INFORMATION

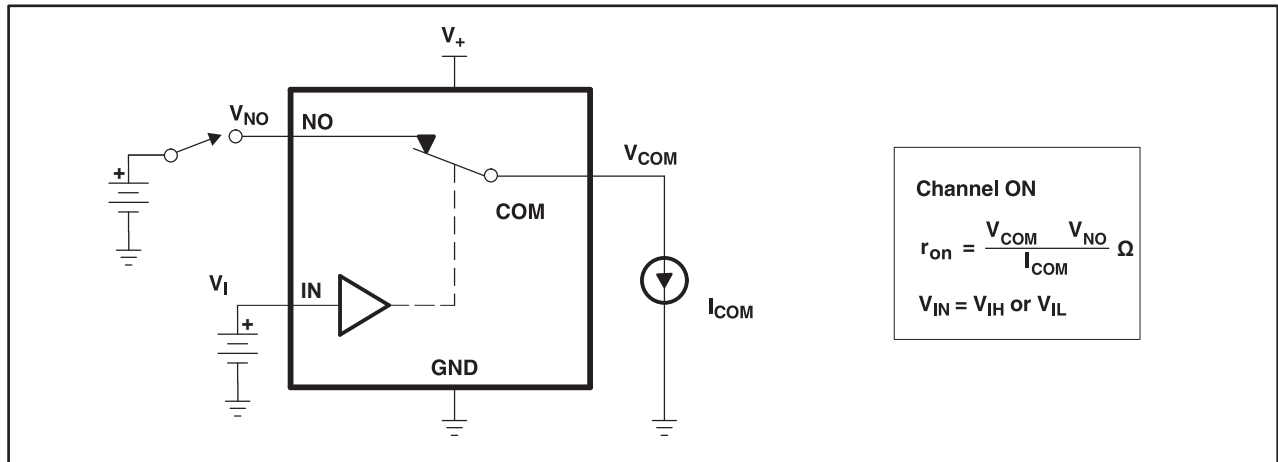

Figure 15. ON-state Resistance (r_{ON})

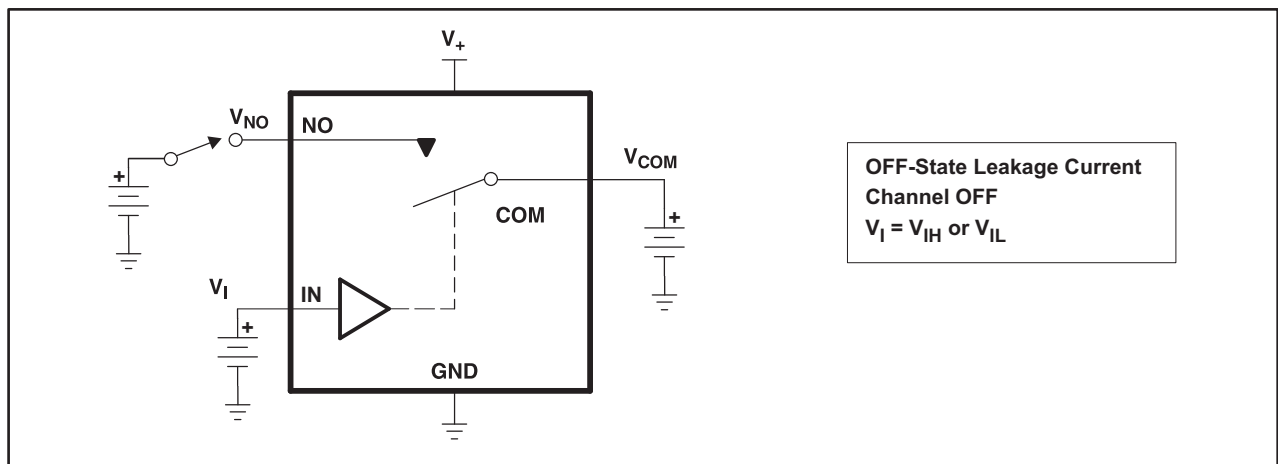

Figure 16. OFF-State Leakage Current
 ($I_{COM(OFF)}$, $I_{NC(OFF)}$, $I_{COM(PWROFF)}$, $I_{NC(PWROFF)}$)

PARAMETER MEASUREMENT INFORMATION (continued)

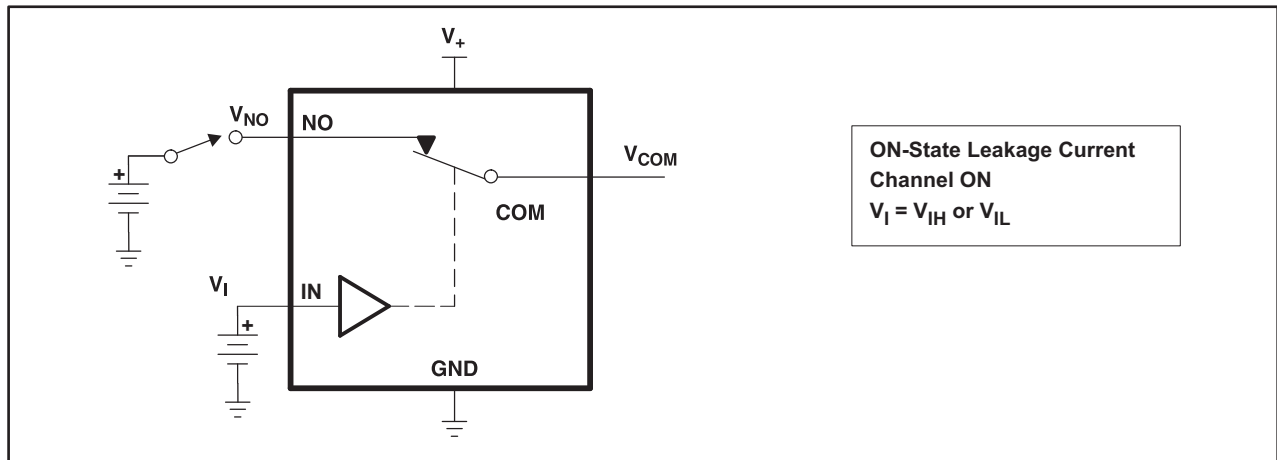

Figure 17. ON-State Leakage Current ($I_{COM(ON)}$, $I_{NC(ON)}$)

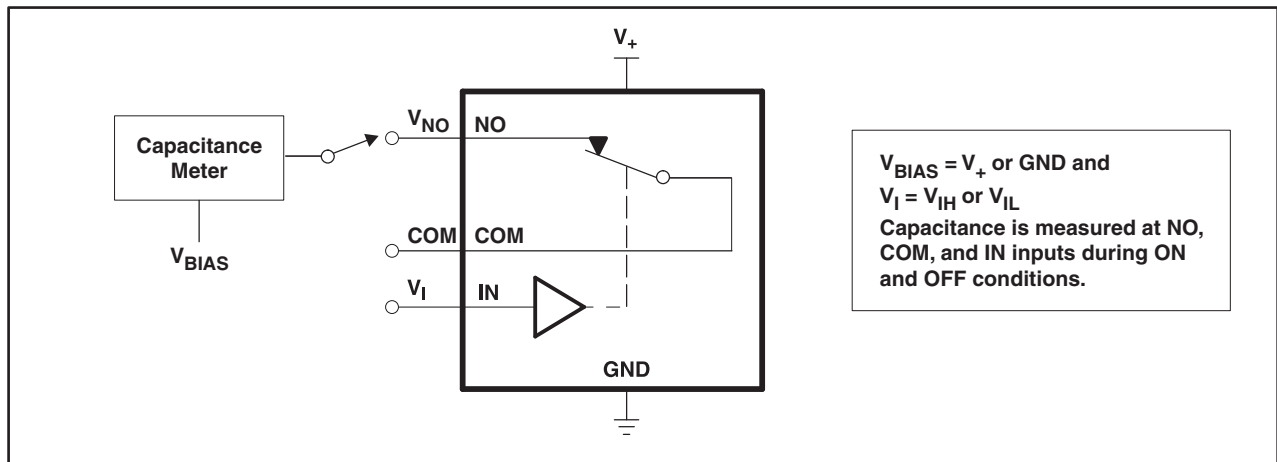

Figure 18. Capacitance (C_I , $C_{COM(OFF)}$, $C_{COM(ON)}$, $C_{NC(OFF)}$, $C_{NC(ON)}$)

- A. All input pulses are supplied by generators having the following characteristics: $PRR \leq 10 \text{ MHz}$, $Z_O = 50 \Omega$, $t_r < 5 \text{ ns}$, $t_f < 5 \text{ ns}$.
- B. C_L includes probe and jig capacitance.

PARAMETER MEASUREMENT INFORMATION (continued)

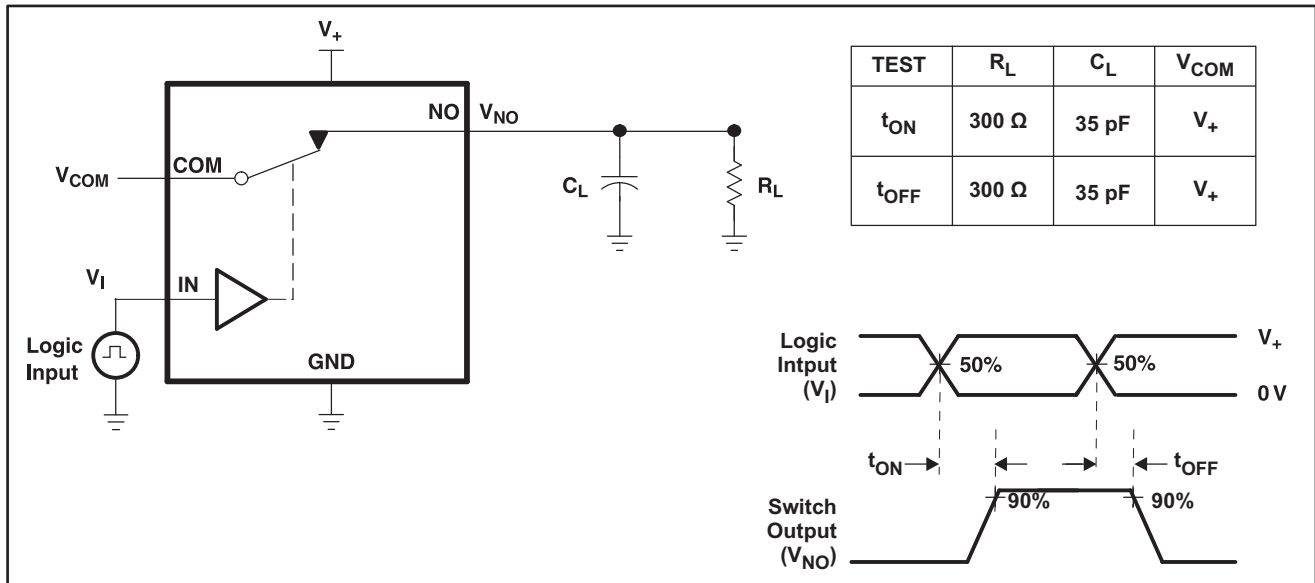

Figure 19. Turn-On (t_{ON}) and Turn-Off Time (t_{OFF})

- A. C_L includes probe and jig capacitance.
- B. All input pulses are supplied by generators having the following characteristics: PRR \leq 10 MHz, $Z_O = 50 \Omega$, $t_r < 5$ ns, $t_f < 5$ ns.

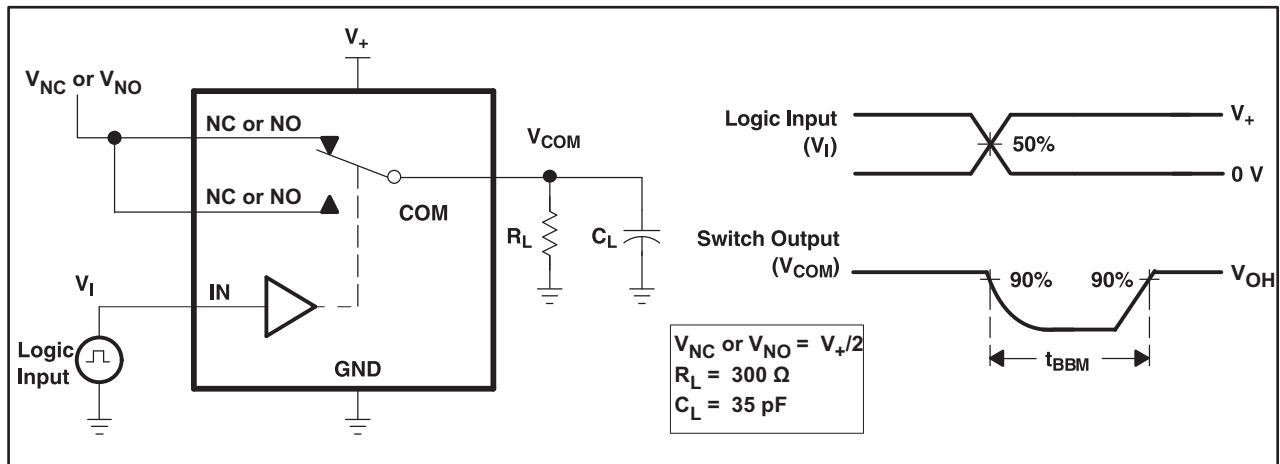

Figure 20. Break-Before-Make Time (t_{BBM})

PARAMETER MEASUREMENT INFORMATION (continued)

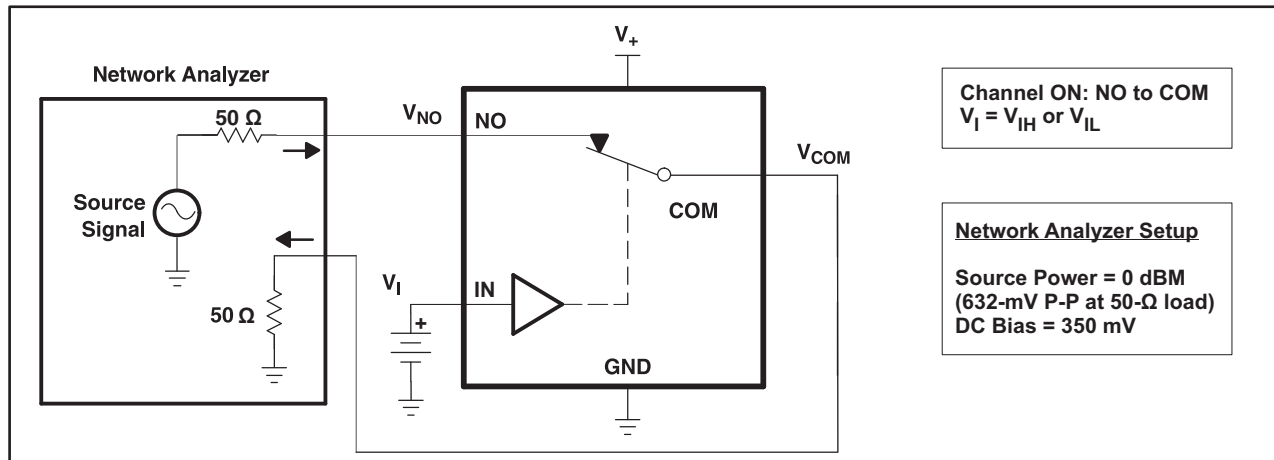

Figure 21. Bandwidth (BW)

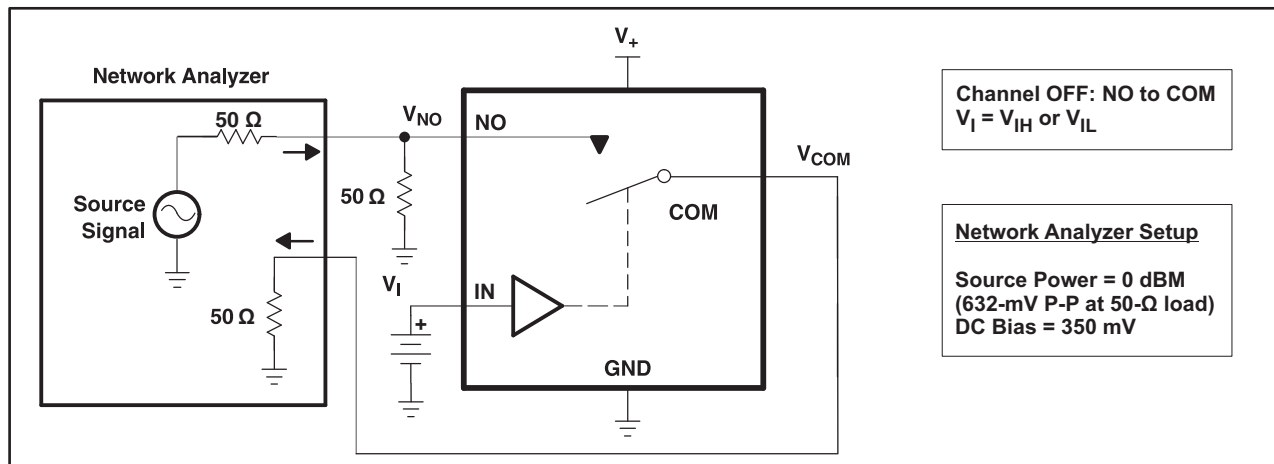

Figure 22. OFF Isolation (O_{ISO})

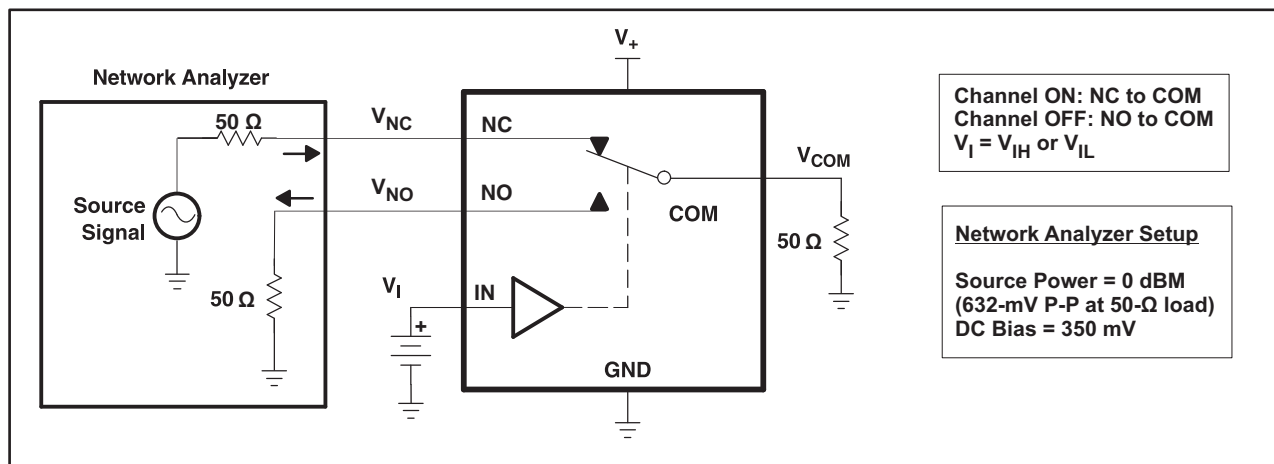

Figure 23. Crosstalk (X_{TALK})

- A. All input pulses are supplied by generators having the following characteristics: $PRR \leq 10$ MHz, $Z_0 = 50 \Omega$, $t_r < 5$ ns, $t_f < 5$ ns.
- B. C_L includes probe and jig capacitance.

PARAMETER MEASUREMENT INFORMATION (continued)

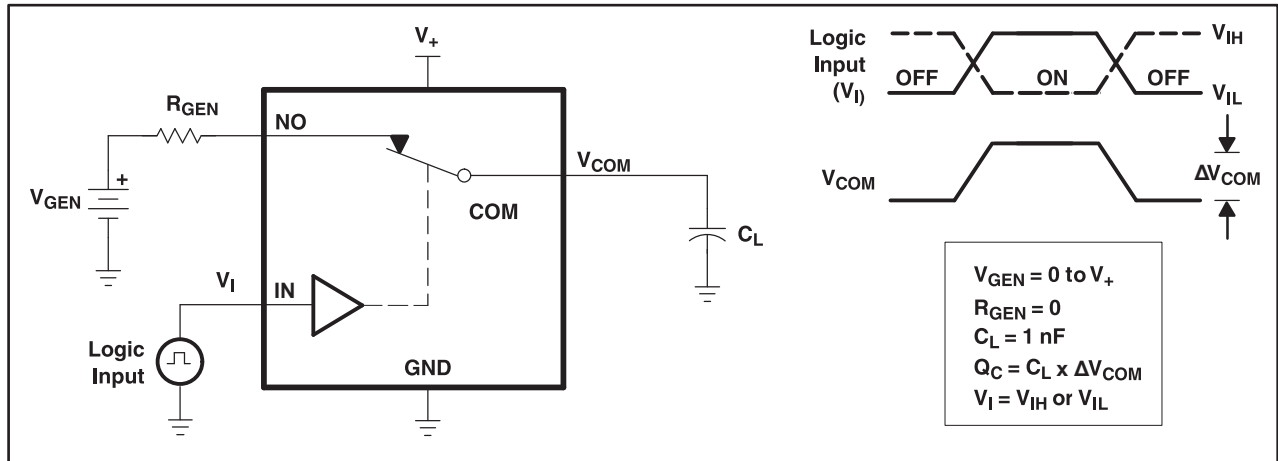

Figure 24. Charge Injection (Q_C)

A. C_L includes probe and jig capacitance.

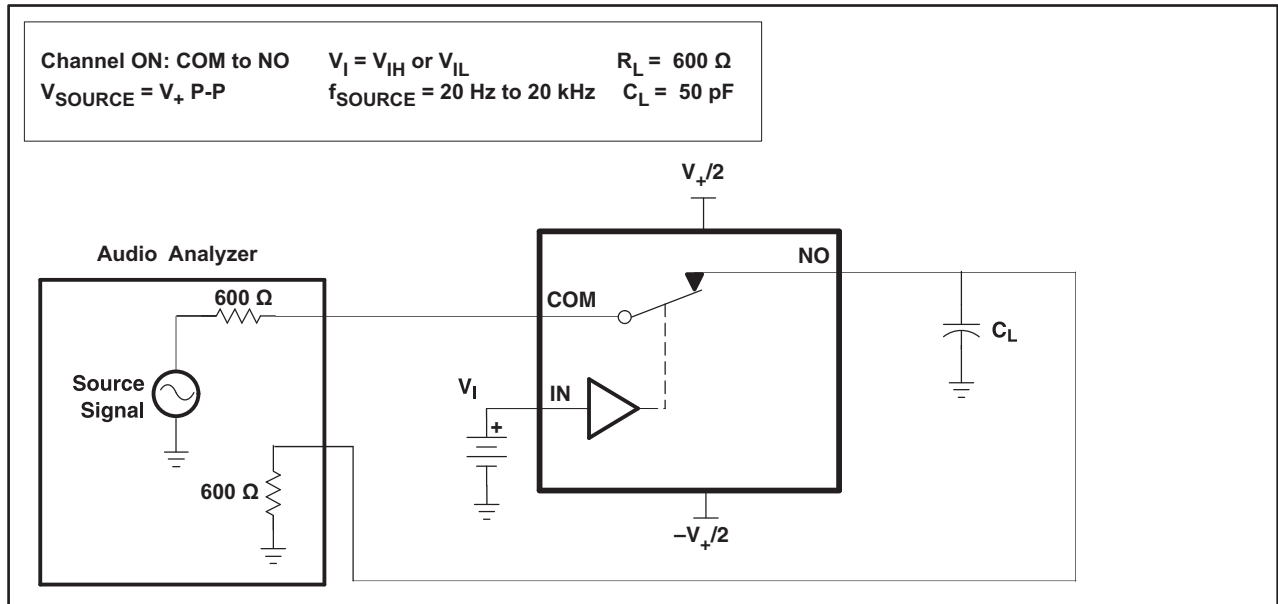

Figure 25. Total Harmonic Distortion (THD)

REVISION HISTORY

Changes from Revision A (August 2009) to Revision B	Page
• Removed QFN reference from product description.	1
• Changed Analog signal range MIN value from $V_+ - 0.5$ to $V_+ - 5.5$	7

PACKAGING INFORMATION

Orderable Device	Status (1)	Package Type	Package Drawing	Pins	Package Qty	Eco Plan (2)	Lead/Ball Finish (6)	MSL Peak Temp (3)	Op Temp (°C)	Device Marking (4/5)	Samples
TS5A22366YFCR	ACTIVE	DSBGA	YFC	12	3000	Green (RoHS & no Sb/Br)	SNAGCU	Level-1-260C-UNLIM	-40 to 85	(3A2 ~ 3AN)	Samples

(1) The marketing status values are defined as follows:

ACTIVE: Product device recommended for new designs.

LIFEBUY: TI has announced that the device will be discontinued, and a lifetime-buy period is in effect.

NRND: Not recommended for new designs. Device is in production to support existing customers, but TI does not recommend using this part in a new design.

PREVIEW: Device has been announced but is not in production. Samples may or may not be available.

OBSELETE: TI has discontinued the production of the device.

(2) Eco Plan - The planned eco-friendly classification: Pb-Free (RoHS), Pb-Free (RoHS Exempt), or Green (RoHS & no Sb/Br) - please check <http://www.ti.com/productcontent> for the latest availability information and additional product content details.

TBD: The Pb-Free/Green conversion plan has not been defined.

Pb-Free (RoHS): TI's terms "Lead-Free" or "Pb-Free" mean semiconductor products that are compatible with the current RoHS requirements for all 6 substances, including the requirement that lead not exceed 0.1% by weight in homogeneous materials. Where designed to be soldered at high temperatures, TI Pb-Free products are suitable for use in specified lead-free processes.

Pb-Free (RoHS Exempt): This component has a RoHS exemption for either 1) lead-based flip-chip solder bumps used between the die and package, or 2) lead-based die adhesive used between the die and leadframe. The component is otherwise considered Pb-Free (RoHS compatible) as defined above.

Green (RoHS & no Sb/Br): TI defines "Green" to mean Pb-Free (RoHS compatible), and free of Bromine (Br) and Antimony (Sb) based flame retardants (Br or Sb do not exceed 0.1% by weight in homogeneous material)

(3) MSL, Peak Temp. - The Moisture Sensitivity Level rating according to the JEDEC industry standard classifications, and peak solder temperature.

(4) There may be additional marking, which relates to the logo, the lot trace code information, or the environmental category on the device.

(5) Multiple Device Markings will be inside parentheses. Only one Device Marking contained in parentheses and separated by a "~" will appear on a device. If a line is indented then it is a continuation of the previous line and the two combined represent the entire Device Marking for that device.

(6) Lead/Ball Finish - Orderable Devices may have multiple material finish options. Finish options are separated by a vertical ruled line. Lead/Ball Finish values may wrap to two lines if the finish value exceeds the maximum column width.

Important Information and Disclaimer: The information provided on this page represents TI's knowledge and belief as of the date that it is provided. TI bases its knowledge and belief on information provided by third parties, and makes no representation or warranty as to the accuracy of such information. Efforts are underway to better integrate information from third parties. TI has taken and continues to take reasonable steps to provide representative and accurate information but may not have conducted destructive testing or chemical analysis on incoming materials and chemicals. TI and TI suppliers consider certain information to be proprietary, and thus CAS numbers and other limited information may not be available for release.

In no event shall TI's liability arising out of such information exceed the total purchase price of the TI part(s) at issue in this document sold by TI to Customer on an annual basis.

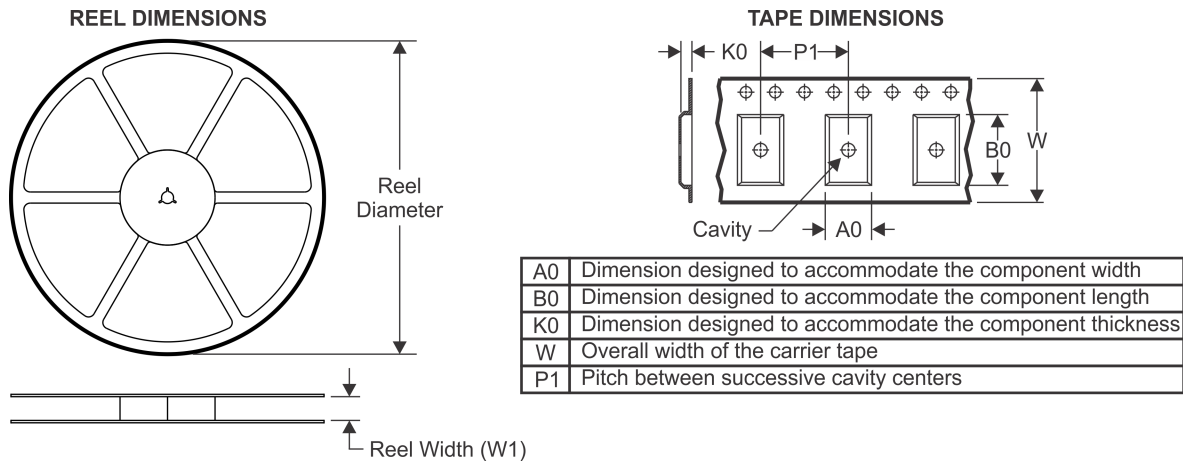
TAPE AND REEL INFORMATION

QUADRANT ASSIGNMENTS FOR PIN 1 ORIENTATION IN TAPE

*All dimensions are nominal

Device	Package Type	Package Drawing	Pins	SPQ	Reel Diameter (mm)	Reel Width W1 (mm)	A0 (mm)	B0 (mm)	K0 (mm)	P1 (mm)	W (mm)	Pin1 Quadrant
TS5A22366YFCR	DSBGA	YFC	12	3000	178.0	9.2	1.29	1.69	0.73	4.0	8.0	Q1

TAPE AND REEL BOX DIMENSIONS



*All dimensions are nominal

Device	Package Type	Package Drawing	Pins	SPQ	Length (mm)	Width (mm)	Height (mm)
TS5A22366YFCR	DSBGA	YFC	12	3000	220.0	220.0	35.0

YFC (R-XBGA-N12)

DIE-SIZE BALL GRID ARRAY

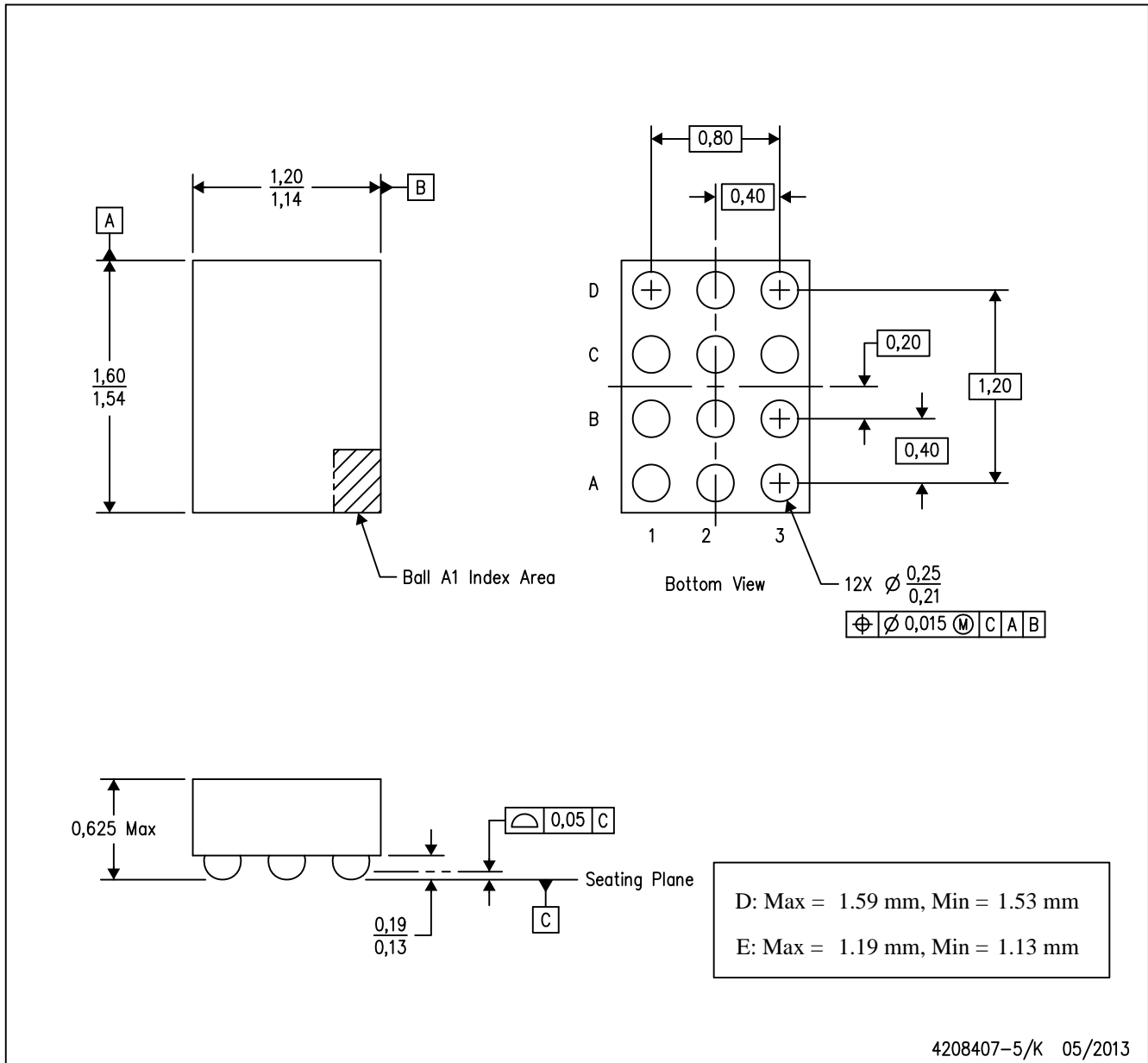

- NOTES:
- A. All linear dimensions are in millimeters. Dimensioning and tolerancing per ASME Y14.5M-1994.
 - B. This drawing is subject to change without notice.
 - C. NanoFree™ package configuration.

NanoFree is a trademark of Texas Instruments.

IMPORTANT NOTICE

Texas Instruments Incorporated and its subsidiaries (TI) reserve the right to make corrections, enhancements, improvements and other changes to its semiconductor products and services per JESD46, latest issue, and to discontinue any product or service per JESD48, latest issue. Buyers should obtain the latest relevant information before placing orders and should verify that such information is current and complete. All semiconductor products (also referred to herein as "components") are sold subject to TI's terms and conditions of sale supplied at the time of order acknowledgment.

TI warrants performance of its components to the specifications applicable at the time of sale, in accordance with the warranty in TI's terms and conditions of sale of semiconductor products. Testing and other quality control techniques are used to the extent TI deems necessary to support this warranty. Except where mandated by applicable law, testing of all parameters of each component is not necessarily performed.

TI assumes no liability for applications assistance or the design of Buyers' products. Buyers are responsible for their products and applications using TI components. To minimize the risks associated with Buyers' products and applications, Buyers should provide adequate design and operating safeguards.

TI does not warrant or represent that any license, either express or implied, is granted under any patent right, copyright, mask work right, or other intellectual property right relating to any combination, machine, or process in which TI components or services are used. Information published by TI regarding third-party products or services does not constitute a license to use such products or services or a warranty or endorsement thereof. Use of such information may require a license from a third party under the patents or other intellectual property of the third party, or a license from TI under the patents or other intellectual property of TI.

Reproduction of significant portions of TI information in TI data books or data sheets is permissible only if reproduction is without alteration and is accompanied by all associated warranties, conditions, limitations, and notices. TI is not responsible or liable for such altered documentation. Information of third parties may be subject to additional restrictions.

Resale of TI components or services with statements different from or beyond the parameters stated by TI for that component or service voids all express and any implied warranties for the associated TI component or service and is an unfair and deceptive business practice. TI is not responsible or liable for any such statements.

Buyer acknowledges and agrees that it is solely responsible for compliance with all legal, regulatory and safety-related requirements concerning its products, and any use of TI components in its applications, notwithstanding any applications-related information or support that may be provided by TI. Buyer represents and agrees that it has all the necessary expertise to create and implement safeguards which anticipate dangerous consequences of failures, monitor failures and their consequences, lessen the likelihood of failures that might cause harm and take appropriate remedial actions. Buyer will fully indemnify TI and its representatives against any damages arising out of the use of any TI components in safety-critical applications.

In some cases, TI components may be promoted specifically to facilitate safety-related applications. With such components, TI's goal is to help enable customers to design and create their own end-product solutions that meet applicable functional safety standards and requirements. Nonetheless, such components are subject to these terms.

No TI components are authorized for use in FDA Class III (or similar life-critical medical equipment) unless authorized officers of the parties have executed a special agreement specifically governing such use.

Only those TI components which TI has specifically designated as military grade or "enhanced plastic" are designed and intended for use in military/aerospace applications or environments. Buyer acknowledges and agrees that any military or aerospace use of TI components which have **not** been so designated is solely at the Buyer's risk, and that Buyer is solely responsible for compliance with all legal and regulatory requirements in connection with such use.

TI has specifically designated certain components as meeting ISO/TS16949 requirements, mainly for automotive use. In any case of use of non-designated products, TI will not be responsible for any failure to meet ISO/TS16949.

Products

Audio	www.ti.com/audio
Amplifiers	amplifier.ti.com
Data Converters	dataconverter.ti.com
DLP® Products	www.dlp.com
DSP	dsp.ti.com
Clocks and Timers	www.ti.com/clocks
Interface	interface.ti.com
Logic	logic.ti.com
Power Mgmt	power.ti.com
Microcontrollers	microcontroller.ti.com
RFID	www.ti-rfid.com
OMAP Applications Processors	www.ti.com/omap
Wireless Connectivity	www.ti.com/wirelessconnectivity

Applications

Automotive and Transportation	www.ti.com/automotive
Communications and Telecom	www.ti.com/communications
Computers and Peripherals	www.ti.com/computers
Consumer Electronics	www.ti.com/consumer-apps
Energy and Lighting	www.ti.com/energy
Industrial	www.ti.com/industrial
Medical	www.ti.com/medical
Security	www.ti.com/security
Space, Avionics and Defense	www.ti.com/space-avionics-defense
Video and Imaging	www.ti.com/video

TI E2E Community

e2e.ti.com