

TS5A3160 1- Ω SPDT Analog Switch

1 Features

- Low ON-State Resistance (1 Ω)
- Isolation in the Powered-Off Mode, $V_+ = 0$
- Specified Make-Before-Break Switching
- Control Inputs are 5-V Tolerant
- Low Charge Injection
- Excellent ON-Resistance Matching
- Low Total Harmonic Distortion
- 1.65-V to 5.5-V Single-Supply Operation
- Latch-Up Performance Exceeds 100 mA Per JESD 78, Class II
- ESD Performance Tested Per JESD 22
 - 2000-V Human Body Model (A114-B, Class II)
 - 1000-V Charged-Device Model (C101)

2 Applications

- Mobile Phones
- Consumer and Computing
- Portable Instrumentation

3 Description

The TS5A3160 device is a single-pole double-throw (SPDT) analog switch that is designed to operate from 1.65 V to 5.5 V. The device offers a low ON-state resistance and an excellent channel-to-channel ON-state resistance matching. The device has excellent total harmonic distortion (THD) performance and consumes very low power. These features make this device suitable for portable audio applications.

Device Information⁽¹⁾

PART NUMBER	PACKAGE	BODY SIZE (NOM)
TS5A3160DBV	SOT-23 (6)	2.90 mm x 1.60 mm
TS5A3160DCK	SC70 (6)	2.00 mm x 1.25 mm

(1) For all available packages, see the orderable addendum at the end of the data sheet.

Block Diagram

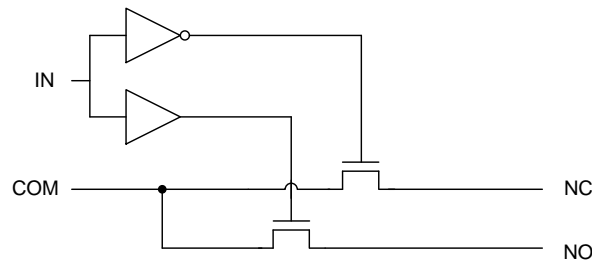

Table of Contents

1 Features 1 2 Applications 1 3 Description 1 4 Revision History 2 5 Pin Configuration and Functions 3 6 Specifications 4 6.1 Absolute Maximum Ratings 4 6.2 ESD Ratings 4 6.3 Recommended Operating Conditions 4 6.4 Thermal Information 4 6.5 Electrical Characteristics for 5-V Supply 5 6.6 Electrical Characteristics for 3.3-V Supply 7 6.7 Electrical Characteristics for 2.5-V Supply 9 6.8 Electrical Characteristics for 1.8-V Supply 11 6.9 Typical Characteristics 13 7 Parameter Measurement Information 15 8 Detailed Description 18 8.1 Overview 18	8.2 Functional Block Diagram 18 8.3 Feature Description 18 8.4 Device Functional Modes 18 9 Application and Implementation 19 9.1 Application Information 19 9.2 Typical Application 19 10 Power Supply Recommendations 20 11 Layout 20 11.1 Layout Guidelines 20 11.2 Layout Example 20 12 Device and Documentation Support 21 12.1 Device Support 21 12.2 Documentation Support 22 12.3 Community Resources 22 12.4 Trademarks 22 12.5 Electrostatic Discharge Caution 22 12.6 Glossary 22 13 Mechanical, Packaging, and Orderable Information 22
---	---

4 Revision History

Changes from Revision C (March 2012) to Revision D

Page

<ul style="list-style-type: none"> • Added <i>Applications</i>, <i>Device Information</i> table, <i>Pin Functions</i> table, <i>ESD Ratings</i> table, <i>Thermal Information</i> table, <i>Typical Characteristics</i>, <i>Feature Description</i> section, <i>Device Functional Modes</i>, <i>Application and Implementation</i> section, <i>Power Supply Recommendations</i> section, <i>Layout</i> section, <i>Device and Documentation Support</i> section, and <i>Mechanical, Packaging, and Orderable Information</i> section. 	1
---	----------

5 Pin Configuration and Functions

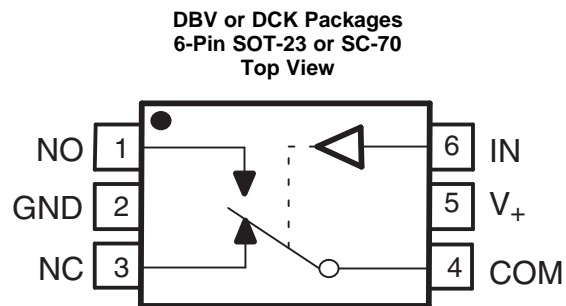

Pin Functions

PIN		I/O	DESCRIPTION
NO.	NAME		
1	NO	I/O	Normally open switch port
2	GND	—	Ground
3	NC	I/O	Normally closed switch port
4	COM	I/O	Common switch port
5	V+	—	Power supply
6	IN	I	Switch select. High = COM connected to NO; Low = COM connected to NC.

6 Specifications

6.1 Absolute Maximum Ratings

over operating free-air temperature range (unless otherwise noted)⁽¹⁾⁽²⁾

		MIN	MAX	UNIT
V ₊	Supply voltage ⁽³⁾	-0.5	6.5	V
V _{NC} V _{NO} V _{COM}	Analog voltage ^{(3) (4) (5)}	-0.5	V ₊ + 0.5	V
I _K	Analog port diode current V _{NC} , V _{NO} , V _{COM} < 0	-50		mA
I _{NC} I _{NO} I _{COM}	On-state switch current On-state peak switch current ⁽⁶⁾ V _{NC} , V _{NO} , V _{COM} = 0 to V ₊	-200 -400	200 400	mA
V _I	Digital input voltage ^{(3) (4)}	-0.5	6.5	V
I _{IK}	Digital input clamp current V _I < 0	-50		mA
I ₊	Continuous current through V ₊		100	mA
I _{GND}	Continuous current through GND	-100		mA
T _{stg}	Storage temperature	-65	150	°C

- (1) Stresses beyond those listed under *Absolute Maximum Ratings* may cause permanent damage to the device. These are stress ratings only, and functional operation of the device at these or any other conditions beyond those indicated under *Recommended Operating Conditions* is not implied. Exposure to absolute-maximum-rated conditions for extended periods may affect device reliability.
- (2) The algebraic convention, whereby the most negative value is a minimum and the most positive value is a maximum
- (3) All voltages are with respect to ground, unless otherwise specified.
- (4) The input and output voltage ratings may be exceeded if the input and output clamp-current ratings are observed.
- (5) This value is limited to 5.5 V maximum.
- (6) Pulse at 1-ms duration < 10% duty cycle

6.2 ESD Ratings

		VALUE	UNIT
V _(ESD)	Electrostatic discharge		
	Human-body model (HBM), per ANSI/ESDA/JEDEC JS-001 ⁽¹⁾	±2000	V
Charged-device model (CDM), per JEDEC specification JESD22-C101 ⁽²⁾	±1000		

- (1) JEDEC document JEP155 states that 500-V HBM allows safe manufacturing with a standard ESD control process.
- (2) JEDEC document JEP157 states that 250-V CDM allows safe manufacturing with a standard ESD control process.

6.3 Recommended Operating Conditions

over operating free-air temperature range (unless otherwise noted)

		MIN	MAX	UNIT
V _{I/O}	Switch input/output voltage	0	V ₊	V
V ₊	Supply voltage	1.65	5.5	V
V _I	Control input voltage	0	5.5	V
T _A	Operating temperature	-40	85	°C

6.4 Thermal Information

THERMAL METRIC ⁽¹⁾	TS5A3160		UNIT	
	DBV (SOT-23)	DCK (SC-70)		
	6 PINS	6 PINS		
R _{θJA}	Junction-to-ambient thermal resistance	165	259	°C/W

- (1) For more information about traditional and new thermal metrics, see the *Semiconductor and IC Package Thermal Metrics* application report, [SPRA953](#).

6.5 Electrical Characteristics for 5-V Supply

 $V_+ = 4.5\text{ V to }5.5\text{ V}$, $T_A = -40^\circ\text{C to }85^\circ\text{C}$ (unless otherwise noted)⁽¹⁾

PARAMETER		TEST CONDITIONS		T_A	V_+	MIN	TYP	MAX	UNIT	
ANALOG SWITCH										
V_{COM}, V_{NC}, V_{NO}	Analog signal range					0		V_+	V	
r_{peak}	Peak ON resistance	$0 \leq (V_{NO} \text{ or } V_{NC}) \leq V_+$, $I_{COM} = -100\text{ mA}$,	Switch ON, see Figure 13	25°C	4.5 V		0.8	1.1	Ω	
				Full			1.5			
r_{on}	ON-state resistance	$V_{NO} \text{ or } V_{NC} = 2.5\text{ V}$, $I_{COM} = -100\text{ mA}$,	Switch ON, see Figure 13	25°C	4.5 V		0.7	0.9	Ω	
				Full			1.1			
Δr_{on}	ON-state resistance match between channels	$V_{NO} \text{ or } V_{NC} = 2.5\text{ V}$, $I_{COM} = -100\text{ mA}$,	Switch ON, see Figure 13	25°C	4.5 V		0.05	0.1	Ω	
				Full			0.1			
$r_{on(Flat)}$	ON-state resistance flatness	$0 \leq (V_{NO} \text{ or } V_{NC}) \leq V_+$, $I_{COM} = -100\text{ mA}$,	Switch ON, see Figure 13	25°C	4.5 V		0.15		Ω	
				25°C			0.1	0.25		
				Full			0.25			
$I_{NC(OFF)}, I_{NO(OFF)}$	NC, NO OFF leakage current	$V_{NC} \text{ or } V_{NO} = 1\text{ V}$, $V_{COM} = 4.5\text{ V}$, or $V_{NO} = 4.5\text{ V}, V_{COM} = 1\text{ V}$,	Switch OFF, see Figure 14	25°C	5.5 V		-20	2	20	nA
				Full			-100	100		
$I_{NC(PWROFF)}, I_{NO(PWROFF)}$		$V_{NC} \text{ or } V_{NO} = 0 \text{ to } 5.5\text{ V}$, $V_{COM} = 5.5\text{ V to } 0$,	Switch OFF, see Figure 14	25°C	0 V		-1	0.2	1	μA
				Full			-20	20		
$I_{NC(ON)}, I_{NO(ON)}$	NC, NO ON leakage current	$V_{NC} \text{ or } V_{NO} = 0 \text{ to } V_+$, $V_{COM} = \text{Open}$,	Switch ON, see Figure 15	25°C	5.5 V		-20	2	20	nA
				Full			-100	100		
$I_{COM(PWROFF)}$	COM OFF leakage current	$V_{COM} = 0 \text{ to } 5.5\text{ V}$, $V_{NC} \text{ or } V_{NO} = 5.5\text{ V to } 0$,	Switch OFF, see Figure 14	25°C	0 V		-1	0.1	1	μA
				Full			-20	20		
$I_{COM(ON)}$	COM ON leakage current	$V_{COM} = 1\text{ V}$, $V_{NC} \text{ or } V_{NO} = \text{Open}$, or $V_{COM} = 4.5\text{ V}$, $V_{NC} \text{ or } V_{NO} = \text{Open}$,	Switch ON, see Figure 15	25°C	5.5 V		-20	2	20	nA
				Full			-100	100		
DIGITAL CONTROL INPUT (IN)⁽²⁾										
V_{IH}	Input logic high			Full		2.4		5.5	V	
V_{IL}	Input logic low			Full		0		0.8	V	
I_{IH}, I_{IL}	Input leakage current	$V_I = 5.5\text{ V or } 0$		25°C	5.5 V		-2	0.2	μA	
				Full			100	100		

(1) The algebraic convention, whereby the most negative value is a minimum and the most positive value is a maximum

(2) All unused digital inputs of the device must be held at V_+ or GND to ensure proper device operation. Refer to the TI application report, *Implications of Slow or Floating CMOS Inputs*, [SCBA004](#).

Electrical Characteristics for 5-V Supply (continued)
 $V_+ = 4.5 \text{ V to } 5.5 \text{ V}$, $T_A = -40^\circ\text{C to } 85^\circ\text{C}$ (unless otherwise noted)⁽¹⁾

PARAMETER		TEST CONDITIONS		T_A	V_+	MIN	TYP	MAX	UNIT
DYNAMIC									
t_{ON}	Turnon time	$V_{COM} = V_+$, $R_L = 50 \Omega$,	$C_L = 35 \text{ pF}$, see Figure 17	25°C	5 V	2	3.5	6	ns
				Full	4.5 V to 5.5 V	1		8	
t_{OFF}	Turnoff time	$V_{COM} = V_+$, $R_L = 50 \Omega$,	$C_L = 35 \text{ pF}$, see Figure 17	25°C	5 V	3	8.5	13	ns
				Full	4.5 V to 5.5 V	2		15	
t_{MBO}	Make-before-break time	$V_{COM} = V_+$, $R_L = 50 \Omega$,	$C_L = 35 \text{ pF}$, see Figure 18	25°C	5 V	2	7	12	ns
				Full	5 V to 5.5 V	2		15	
Q_C	Charge injection	$V_{GEN} = 0$, $R_{GEN} = 0$,	$C_L = 1 \text{ nF}$, see Figure 22	25°C	5 V		36.5		pC
$C_{NC(OFF)}$, $C_{NO(OFF)}$	NC, NO OFF capacitance	V_{NC} or $V_{NO} = V_+$ or GND, Switch OFF,	See Figure 16	25°C	5 V		18		pF
$C_{NC(ON)}$, $C_{NO(ON)}$	NC, NO ON capacitance	V_{NC} or $V_{NO} = V_+$ or GND, Switch ON,	See Figure 16	25°C	5 V		55		pF
$C_{COM(ON)}$	COM ON capacitance	$V_{COM} = V_+$ or GND, Switch ON,	See Figure 16	25°C	5 V		55		pF
C_I	Digital input capacitance	$V_I = V_+$ or GND,	See Figure 16	25°C	5 V		2		pF
BW	Bandwidth	$R_L = 50 \Omega$, Switch ON,	See Figure 19	25°C	5 V		100		MHz
O_{ISO}	OFF isolation	$R_L = 50 \Omega$, $f = 10 \text{ MHz}$,	See Figure 20	25°C	5 V		-64		dB
X_{TALK}	Crosstalk	$R_L = 50 \Omega$, $f = 1 \text{ MHz}$,	See Figure 20	25°C	5 V		-64		dB
THD	Total harmonic distortion	$R_L = 600 \Omega$, $C_L = 50 \text{ pF}$,	$f = 20 \text{ Hz to } 20 \text{ kHz}$, see Figure 23	25°C	5 V		0.004%		
SUPPLY									
I_+	Positive supply current	$V_I = V_+$ or GND		25°C	5.5 V		10	50	nA
				Full				500	

6.6 Electrical Characteristics for 3.3-V Supply

 $V_+ = 3\text{ V to }3.6\text{ V}$, $T_A = -40^\circ\text{C to }85^\circ\text{C}$ (unless otherwise noted)⁽¹⁾

PARAMETER		TEST CONDITIONS		T_A	V_+	MIN	TYP	MAX	UNIT
ANALOG SWITCH									
V_{COM}, V_{NC}, V_{NO}	Analog signal range					0		V_+	V
r_{peak}	Peak ON resistance	$0 \leq (V_{NO} \text{ or } V_{NC}) \leq V_+$, $I_{COM} = -100\text{ mA}$,	Switch ON, see Figure 13	25°C	3 V		1.3	1.6	Ω
				Full				2	
r_{on}	ON-state resistance	$V_{NO} \text{ or } V_{NC} = 2\text{ V}$, $I_{COM} = -100\text{ mA}$,	Switch ON, see Figure 13	25°C	3 V		1.2	1.5	Ω
				Full				1.7	
Δr_{on}	ON-state resistance match between channels	$V_{NO} \text{ or } V_{NC} = 2\text{ V}, 0.8\text{ V}$, $I_{COM} = -100\text{ mA}$,	Switch ON, see Figure 13	25°C	3 V		0.1	0.15	Ω
				Full				0.15	
$r_{on(Flat)}$	ON-state resistance flatness	$0 \leq (V_{NO} \text{ or } V_{NC}) \leq V_+$, $I_{COM} = -100\text{ mA}$,	Switch ON, see Figure 13	25°C	3 V		0.2		Ω
				25°C			0.15	0.3	
				Full			0.3		
$I_{NC(OFF)}, I_{NO(OFF)}$	NC, NO OFF leakage current	$V_{NC} \text{ or } V_{NO} = 1\text{ V}$, $V_{COM} = 3\text{ V}$, or $V_{NC} \text{ or } V_{NO} = 3\text{ V}$, $V_{COM} = 1\text{ V}$,	Switch OFF, see Figure 14	25°C	3.6 V	-20	2	20	nA
				Full		-50		50	
$I_{NC(PWROFF)}, I_{NO(PWROFF)}$		$V_{NC} \text{ or } V_{NO} = 0 \text{ to } 3.6\text{ V}$, $V_{COM} = 3.6\text{ V to } 0$,	Switch OFF, see Figure 14	25°C	0 V	-1	0.2	1	μA
				Full		-15		15	
$I_{NC(ON)}, I_{NO(ON)}$	NC, NO ON leakage current	$V_{NC} \text{ or } V_{NO} = 1\text{ V}$, $V_{COM} = \text{Open}$, or $V_{NC} \text{ or } V_{NO} = 3\text{ V}$, $V_{COM} = \text{Open}$,	Switch ON, see Figure 15	25°C	3.6 V	-10	2	10	nA
				Full		-20		20	
$I_{COM(PWROFF)}$	COM OFF leakage current	$V_{COM} = 0 \text{ to } 3.6\text{ V}$, $V_{NC} \text{ or } V_{NO} = 3.6\text{ V to } 0$,	Switch OFF, see Figure 14	25°C	0 V	-1	0.2	1	μA
				Full		-15		15	
$I_{COM(ON)}$	COM ON leakage current	$V_{COM} = 1\text{ V}$, $V_{NC} \text{ or } V_{NO} = \text{Open}$, or $V_{COM} = 3\text{ V}$, $V_{NC} \text{ or } V_{NO} = \text{Open}$,	Switch ON, see Figure 15	25°C	3.6 V	-10	2	10	nA
				Full		-20		20	
DIGITAL CONTROL INPUT (IN)⁽²⁾									
V_{IH}	Input logic high			Full		2		5.5	V
V_{IL}	Input logic low			Full		0		0.8	V
I_{IH}, I_{IL}	Input leakage current	$V_I = 5.5\text{ V or } 0$		25°C	3.6 V	-2		2	nA
				Full		-100		100	

(1) The algebraic convention, whereby the most negative value is a minimum and the most positive value is a maximum

(2) All unused digital inputs of the device must be held at V_+ or GND to ensure proper device operation. Refer to the TI application report, [Implications of Slow or Floating CMOS Inputs, SCBA004](#).

Electrical Characteristics for 3.3-V Supply (continued)
 $V_+ = 3\text{ V to }3.6\text{ V}$, $T_A = -40^\circ\text{C to }85^\circ\text{C}$ (unless otherwise noted)⁽¹⁾

PARAMETER		TEST CONDITIONS		T_A	V_+	MIN	TYP	MAX	UNIT
DYNAMIC									
t_{ON}	Turnon time	$V_{COM} = V_+$, $R_L = 50\ \Omega$,	$C_L = 35\text{ pF}$, see Figure 17	25°C	3.3 V	2	4.5	13	ns
				Full	3 V to 3.6 V	1		15	
t_{OFF}	Turnoff time	$V_{COM} = V_+$, $R_L = 50\ \Omega$,	$C_L = 35\text{ pF}$, see Figure 17	25°C	3.3 V	3	9	15	ns
				Full	3 V to 3.6 V	2		20	
t_{MBB}	Make-before-break time	$V_{COM} = V_+$, $R_L = 50\ \Omega$,	$C_L = 35\text{ pF}$, see Figure 18	25°C	3.3 V	1	7	12	ns
				Full	3 V to 3.6 V	1		15	
Q_C	Charge injection	$V_{GEN} = 0$, $R_{GEN} = 0$,	$C_L = 1\text{ nF}$, see Figure 22	25°C	3.3 V		20		pC
$C_{NC(OFF)}$, $C_{NO(OFF)}$	NC, NO OFF capacitance	V_{NC} or $V_{NO} = V_+$ or GND, Switch OFF,	See Figure 16	25°C	3.3 V		18		pF
$C_{NC(ON)}$, $C_{NO(ON)}$	NC, NO ON capacitance	V_{NC} or $V_{NO} = V_+$ or GND, Switch ON,	See Figure 16	25°C	3.3 V		55		pF
$C_{COM(ON)}$	COM ON capacitance	$V_{COM} = V_+$ or GND, Switch ON,	See Figure 16	25°C	3.3 V		55		pF
C_I	Digital input capacitance	$V_I = V_+$ or GND,	See Figure 16	25°C	3.3 V		2		pF
BW	Bandwidth	$R_L = 50\ \Omega$, Switch ON,	See Figure 19	25°C	3.3 V		100		MHz
O_{ISO}	OFF isolation	$R_L = 50\ \Omega$, $f = 10\text{ MHz}$,	See Figure 20	25°C	3.3 V		-64		dB
X_{TALK}	Crosstalk	$R_L = 50\ \Omega$, $f = 1\text{ MHz}$,	See Figure 20	25°C	3.3 V		-64		dB
THD	Total harmonic distortion	$R_L = 600\ \Omega$, $C_L = 50\text{ pF}$,	$f = 20\text{ Hz to }20\text{ kHz}$, see Figure 23	25°C	3.3 V		0.01%		
SUPPLY									
I_+	Positive supply current	$V_I = V_+$ or GND		25°C	3.6 V		10	30	nA
				Full				100	

6.7 Electrical Characteristics for 2.5-V Supply

 $V_+ = 2.3 \text{ V to } 2.7 \text{ V}$, $T_A = -40^\circ\text{C to } 85^\circ\text{C}$ (unless otherwise noted)⁽¹⁾

PARAMETER		TEST CONDITIONS		T_A	V_+	MIN	TYP	MAX	UNIT	
ANALOG SWITCH										
V_{COM} , V_{NC} , V_{NO}	Analog signal range					0		V_+	V	
r_{peak}	Peak ON resistance	$0 \leq (V_{NO} \text{ or } V_{NC}) \leq V_+$, $I_{COM} = -8 \text{ mA}$,	Switch ON, see Figure 13	25°C	2.3 V		1.8	2.5	Ω	
				Full			2.7			
r_{on}	ON-state resistance	$V_{NO} \text{ or } V_{NC} = 1.8 \text{ V}$, $I_{COM} = -8 \text{ mA}$,	Switch ON, see Figure 13	25°C	2.3 V		1.5	2	Ω	
				Full			2.4			
Δr_{on}	ON-state resistance match between channels	$V_{NO} \text{ or } V_{NC} = 1.8 \text{ V}$, $I_{COM} = -8 \text{ mA}$,	Switch ON, see Figure 13	25°C	2.3 V		0.15	0.2	Ω	
				Full			0.2			
$r_{on(Flat)}$	ON-state resistance flatness	$0 \leq (V_{NO} \text{ or } V_{NC}) \leq V_+$, $I_{COM} = -8 \text{ mA}$,	Switch ON, see Figure 13	25°C	2.3 V		2.6		Ω	
				25°C			0.6	1		
				Full				1		
$I_{NC(OFF)}$, $I_{NO(OFF)}$	NC, NO OFF leakage current	$V_{NC} \text{ or } V_{NO} = 0.5 \text{ V}$, $V_{COM} = 2.2 \text{ V}$, or $V_{NC} \text{ or } V_{NO} = 2.2 \text{ V}$, $V_{COM} = 0.5 \text{ V}$,	Switch OFF, see Figure 14	25°C	2.3 V		-20	2	20	nA
				Full			-50	50		
$I_{NC(PWROFF)}$, $I_{NO(PWROFF)}$		$V_{NC} \text{ or } V_{NO} = 0 \text{ to } 2.7 \text{ V}$, $V_{COM} = 2.7 \text{ V to } 0$,	Switch OFF, see Figure 14	25°C	0 V		-1	0.1	1	μA
				Full			-10	10		
$I_{NC(ON)}$, $I_{NO(ON)}$	NC, NO ON leakage current	$V_{NC} \text{ or } V_{NO} = 0.5 \text{ V}$, $V_{COM} = \text{Open}$, or $V_{NC} \text{ or } V_{NO} = 2.2 \text{ V}$, $V_{COM} = \text{Open}$,	Switch ON, see Figure 15	25°C	2.7 V		-10	2	10	nA
				Full			-20	20		
$I_{COM(PWROFF)}$	COM OFF leakage current	$V_{COM} = 0 \text{ to } 2.7 \text{ V}$, $V_{NC} \text{ or } V_{NO} = 2.7 \text{ V to } 0$,	Switch OFF, see Figure 14	25°C	0 V		-1	0.1	1	μA
				Full			-10	10		
$I_{COM(ON)}$	COM ON leakage current	$V_{COM} = 0.5 \text{ V}$, $V_{NC} \text{ or } V_{NO} = \text{Open}$, or $V_{COM} = 2.2 \text{ V}$, $V_{NC} \text{ or } V_{NO} = \text{Open}$,	Switch ON, see Figure 15	25°C	2.7 V		-10	2	10	nA
				Full			-20	20		
DIGITAL CONTROL INPUT (IN)⁽²⁾										
V_{IH}	Input logic high			Full		1.8		5.5	V	
V_{IL}	Input logic low			Full		0		0.6	V	
I_{IH} , I_{IL}	Input leakage current	$V_I = 5.5 \text{ V or } 0$		25°C	2.7 V		-2	2	nA	
				Full			-20	20		

(1) The algebraic convention, whereby the most negative value is a minimum and the most positive value is a maximum

(2) All unused digital inputs of the device must be held at V_+ or GND to ensure proper device operation. Refer to the TI application report, *Implications of Slow or Floating CMOS Inputs*, [SCBA004](#).

Electrical Characteristics for 2.5-V Supply (continued)
 $V_+ = 2.3 \text{ V to } 2.7 \text{ V}$, $T_A = -40^\circ\text{C to } 85^\circ\text{C}$ (unless otherwise noted)⁽¹⁾

PARAMETER		TEST CONDITIONS		T_A	V_+	MIN	TYP	MAX	UNIT
DYNAMIC									
t_{ON}	Turnon time	$V_{COM} = V_+$, $R_L = 50 \Omega$,	$C_L = 35 \text{ pF}$, see Figure 17	25°C	2.5 V	2	6.5	15	ns
				Full	2.3 V to 2.7 V	1		17	
t_{OFF}	Turnoff time	$V_{COM} = V_+$, $R_L = 50 \Omega$,	$C_L = 35 \text{ pF}$, see Figure 17	25°C	2.5 V	3	11	18	ns
				Full	2.3 V to 2.7 V	2		20	
t_{MBB}	Make-before-break time	$V_{COM} = V_+$, $R_L = 50 \Omega$,	$C_L = 35 \text{ pF}$, see Figure 18	25°C	2.5 V	1	8	12	ns
				Full	2.3 V to 2.7 V	1		15	
Q_C	Charge injection	$V_{GEN} = 0$, $R_{GEN} = 0$,	$C_L = 1 \text{ nF}$, see Figure 22	25°C	2.5 V		12		pC
$C_{NC(OFF)}$, $C_{NO(OFF)}$	NC, NO OFF capacitance	V_{NC} or $V_{NO} = V_+$ or GND, Switch OFF,	See Figure 16	25°C	2.5 V		18		pF
$C_{NC(ON)}$, $C_{NO(ON)}$	NC, NO ON capacitance	V_{NC} or $V_{NO} = V_+$ or GND, Switch ON,	See Figure 16	25°C	2.5 V		55		pF
$C_{COM(ON)}$	COM ON capacitance	$V_{COM} = V_+$ or GND, Switch ON,	See Figure 16	25°C	2.5 V		55		pF
C_I	Digital input capacitance	$V_I = V_+$ or GND,	See Figure 16	25°C	2.5 V		2		pF
BW	Bandwidth	$R_L = 50 \Omega$, Switch ON,	See Figure 19	25°C	2.5 V		100		MHz
O_{ISO}	OFF isolation	$R_L = 50 \Omega$, $f = 10 \text{ MHz}$,	See Figure 20	25°C	2.5 V		-64		dB
X_{TALK}	Crosstalk	$R_L = 50 \Omega$, $f = 1 \text{ MHz}$,	See Figure 20	25°C	2.5 V		-64		dB
THD	Total harmonic distortion	$R_L = 600 \Omega$, $C_L = 50 \text{ pF}$,	$f = 20 \text{ Hz to } 20 \text{ kHz}$, see Figure 23	25°C	2.5 V		0.02%		
SUPPLY									
I_+	Positive supply current	$V_I = V_+$ or GND		25°C	2.7 V		10	30	nA
				Full				50	

6.8 Electrical Characteristics for 1.8-V Supply

 $V_+ = 1.65\text{ V to }1.95\text{ V}$, $T_A = -40^\circ\text{C to }85^\circ\text{C}$ (unless otherwise noted)⁽¹⁾

PARAMETER		TEST CONDITIONS		T_A	V_+	MIN	TYP	MAX	UNIT
ANALOG SWITCH									
V_{COM} , V_{NC} , V_{NO}	Analog signal range					0		V_+	V
r_{peak}	Peak ON resistance	$0 \leq (V_{NO} \text{ or } V_{NC}) \leq V_+$, $I_{COM} = -2\text{ mA}$,	Switch ON, see Figure 13	25°C	1.65 V	5			Ω
				Full		15			
r_{on}	ON-state resistance	$V_{NO} \text{ or } V_{NC} = 1.5\text{ V}$, $I_{COM} = -2\text{ mA}$,	Switch ON, see Figure 13	25°C	1.65 V	2 2.5			Ω
				Full		3.5			
Δr_{on}	ON-state resistance match between channels	$V_{NO} \text{ or } V_{NC} = 1.5\text{ V}$, $I_{COM} = -2\text{ mA}$,	Switch ON, see Figure 13	25°C	1.65 V	0.15 0.4			Ω
				Full		0.4			
$r_{on(Flat)}$	ON-state resistance flatness	$0 \leq (V_{NO} \text{ or } V_{NC}) \leq V_+$, $I_{COM} = -2\text{ mA}$,	Switch ON, see Figure 13	25°C	1.65 V	5			Ω
				25°C		4.5			
				Full					
$I_{NC(OFF)}$, $I_{NO(OFF)}$	NC, NO OFF leakage current	$V_{NC} \text{ or } V_{NO} = 0.3\text{ V}$, $V_{COM} = 1.65\text{ V}$, or $V_{NC} \text{ or } V_{NO} = 1.65\text{ V}$, $V_{COM} = 0.3\text{ V}$,	Switch OFF, see Figure 14	25°C	1.95 V	-5	2	5	nA
				Full		-20		20	
$I_{NC(PWROFF)}$, $I_{NO(PWROFF)}$		$V_{NC} \text{ or } V_{NO} = 0 \text{ to } 1.95\text{ V}$, $V_{COM} = 1.95\text{ V to } 0$,	Switch OFF, see Figure 14	25°C	0 V	-1	0.1	1	μA
				Full		-5		5	
$I_{NC(ON)}$, $I_{NO(ON)}$	NC, NO ON leakage current	$V_{NC} \text{ or } V_{NO} = 0.3\text{ V}$, $V_{COM} = \text{Open}$, or $V_{NC} \text{ or } V_{NO} = 1.65\text{ V}$, $V_{COM} = \text{Open}$,	Switch ON, see Figure 15	25°C	1.95 V	-5	2	5	nA
				Full		-20		20	
$I_{COM(PWROFF)}$	COM OFF leakage current	$V_{COM} = 0 \text{ to } 1.95\text{ V}$, $V_{NC} \text{ or } V_{NO} = 1.95\text{ V to } 0$,	Switch OFF, see Figure 14	25°C	0 V	-1	0.1	1	μA
				Full		-5		5	
$I_{COM(ON)}$	COM ON leakage current	$V_{COM} = 0.3\text{ V}$, $V_{NC} \text{ or } V_{NO} = \text{Open}$, or $V_{COM} = 1.65\text{ V}$, $V_{NC} \text{ or } V_{NO} = \text{Open}$,	Switch ON, see Figure 15	25°C	1.95 V	-5	2	5	nA
				Full		-20		20	
DIGITAL CONTROL INPUT (IN)⁽²⁾									
V_{IH}	Input logic high			Full		1.5		5.5	V
V_{IL}	Input logic low			Full		0		0.6	V
I_{IH} , I_{IL}	Input leakage current	$V_I = 5.5\text{ V or } 0$		25°C	1.95 V	-2 2			nA
				Full		-20 20			

(1) The algebraic convention, whereby the most negative value is a minimum and the most positive value is a maximum

(2) All unused digital inputs of the device must be held at V_+ or GND to ensure proper device operation. Refer to the TI application report, *Implications of Slow or Floating CMOS Inputs*, [SCBA004](#).

Electrical Characteristics for 1.8-V Supply (continued)
 $V_+ = 1.65\text{ V to }1.95\text{ V}$, $T_A = -40^\circ\text{C to }85^\circ\text{C}$ (unless otherwise noted)⁽¹⁾

PARAMETER		TEST CONDITIONS		T_A	V_+	MIN	TYP	MAX	UNIT
DYNAMIC									
t_{ON}	Turnon time	$V_{COM} = V_+$, $R_L = 50\ \Omega$,	$C_L = 35\text{ pF}$, see Figure 17	25°C	1.8 V	6	13	24	ns
				Full	2.3 V to 2.7 V	5		27	
t_{OFF}	Turnoff time	$V_{COM} = V_+$, $R_L = 50\ \Omega$,	$C_L = 35\text{ pF}$, see Figure 17	25°C	1.8 V	6	15	27	ns
				Full	2.3 V to 2.7 V	5		30	
t_{MBO}	Make-before-break time	$V_{COM} = V_+$, $R_L = 50\ \Omega$,	$C_L = 35\text{ pF}$, see Figure 18	25°C	1.8 V	2	7	12	ns
				Full	2.3 V to 2.7 V	2		15	
Q_C	Charge injection	$V_{GEN} = 0$, $R_{GEN} = 0$,	$C_L = 1\text{ nF}$, see Figure 22	25°C	1.8 V		5.5		pC
$C_{NC(OFF)}$, $C_{NO(OFF)}$	NC, NO OFF capacitance	V_{NC} or $V_{NO} = V_+$ or GND, Switch OFF,	See Figure 16	25°C	1.8 V		18		pF
$C_{NC(ON)}$, $C_{NO(ON)}$	NC, NO ON capacitance	V_{NC} or $V_{NO} = V_+$ or GND, Switch ON,	See Figure 16	25°C	1.8 V		55		pF
$C_{COM(ON)}$	COM ON capacitance	$V_{COM} = V_+$ or GND, Switch ON,	See Figure 16	25°C	1.8 V		55		pF
C_I	Digital input capacitance	$V_I = V_+$ or GND,	See Figure 16	25°C	1.8 V		2		pF
BW	Bandwidth	$R_L = 50\ \Omega$, Switch ON,	See Figure 19	25°C	1.8 V		105		MHz
O_{ISO}	OFF isolation	$R_L = 50\ \Omega$, $f = 10\text{ MHz}$,	See Figure 20	25°C	1.8 V		-64		dB
X_{TALK}	Crosstalk	$R_L = 50\ \Omega$, $f = 1\text{ MHz}$,	See Figure 20	25°C	1.8 V		-64		dB
THD	Total harmonic distortion	$R_L = 600\ \Omega$, $C_L = 50\text{ pF}$,	$f = 20\text{ Hz to }20\text{ kHz}$, see Figure 23	25°C	1.8 V		0.06%		
SUPPLY									
I_+	Positive supply current	$V_I = V_+$ or GND		25°C	1.95 V		5	15	nA
				Full				50	

6.9 Typical Characteristics

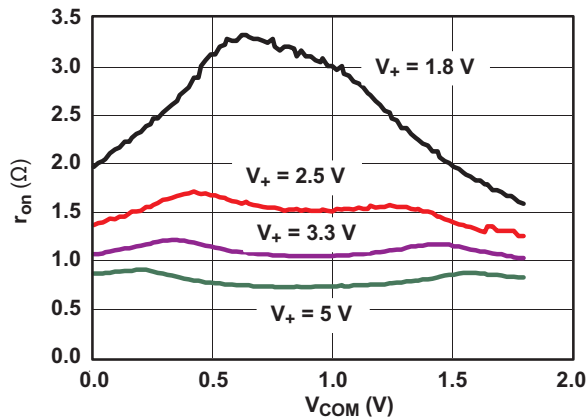

Figure 1. r_{on} vs V_{COM}

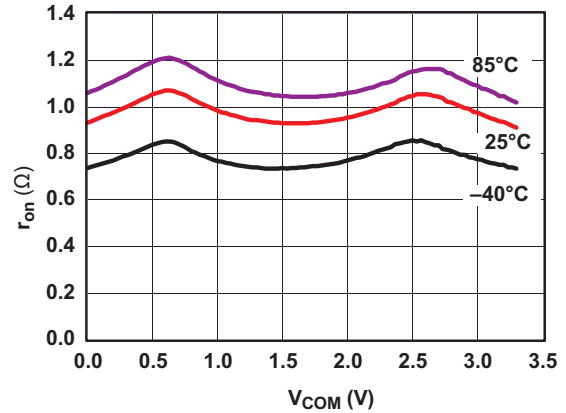

Figure 2. r_{on} vs V_{COM} ($V_+ = 3.3$ V)

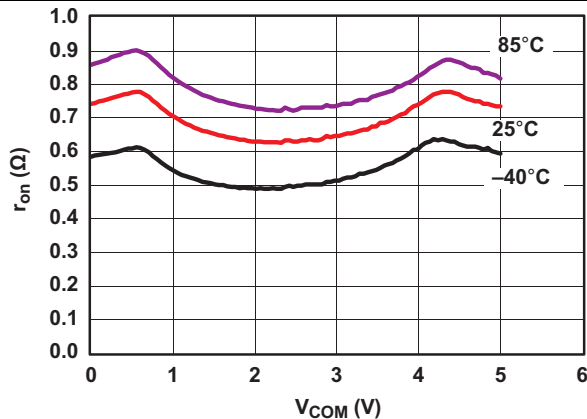

Figure 3. r_{on} vs V_{COM} ($V_+ = 5$ V)

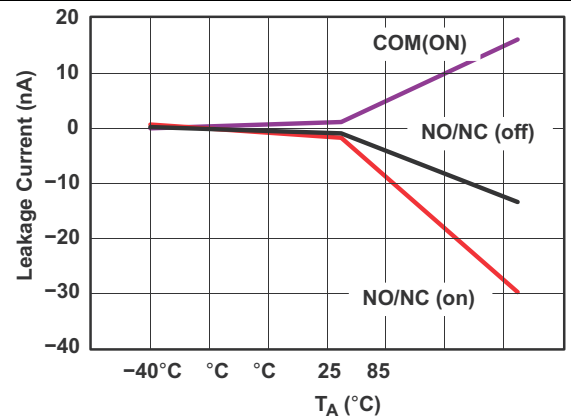

Figure 4. Leakage Current vs Temperature ($V_+ = 5.5$ V)

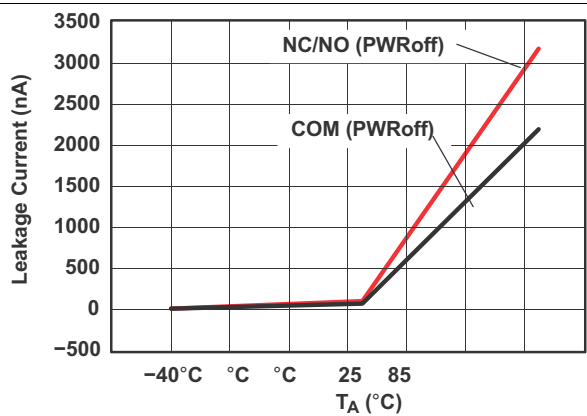

Figure 5. Leakage Current vs Temperature ($V_+ = 5$ V)

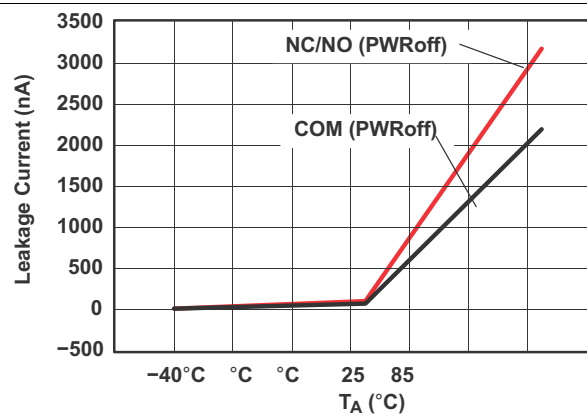

Figure 6. Charge Injection (Q_c) vs V_{COM}

Typical Characteristics (continued)

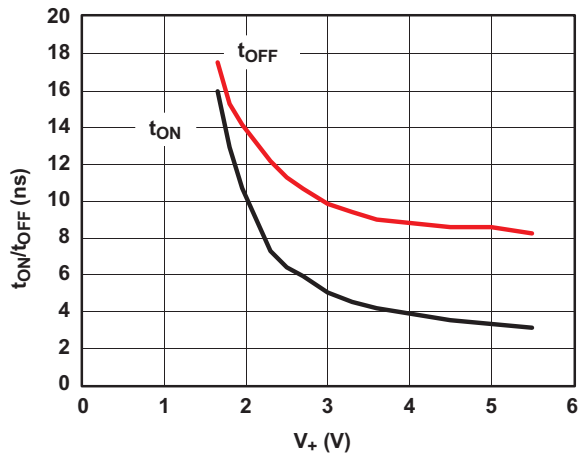

Figure 7. t_{ON} and t_{OFF} vs Supply Voltage

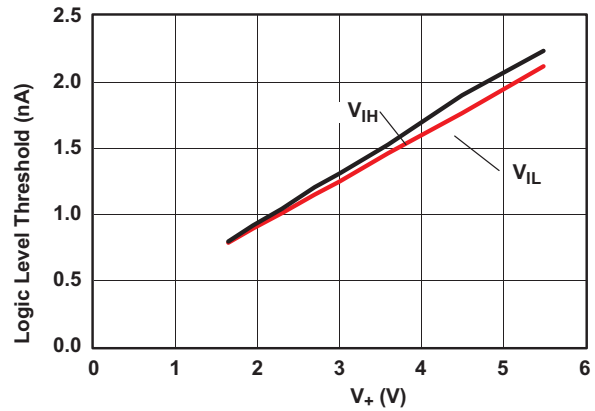

Figure 8. Logic-Level Threshold vs V_+

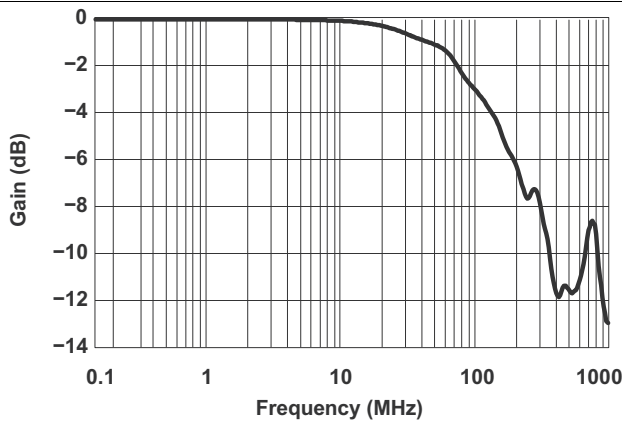

Figure 9. Bandwidth (Gain vs Frequency) ($V_+ = 5\text{ V}$)

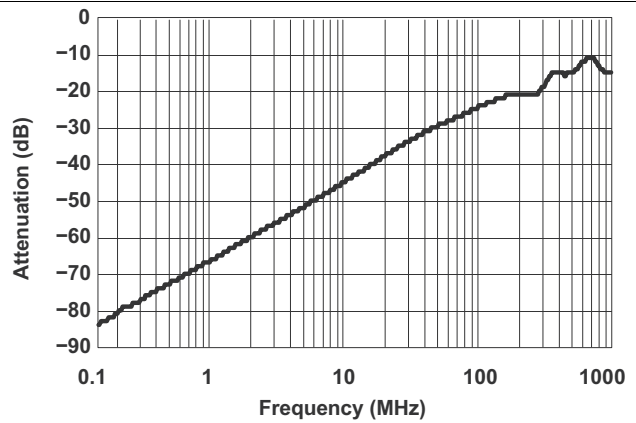

Figure 10. OFF Isolation vs Crosstalk ($V_+ = 5\text{ V}$)

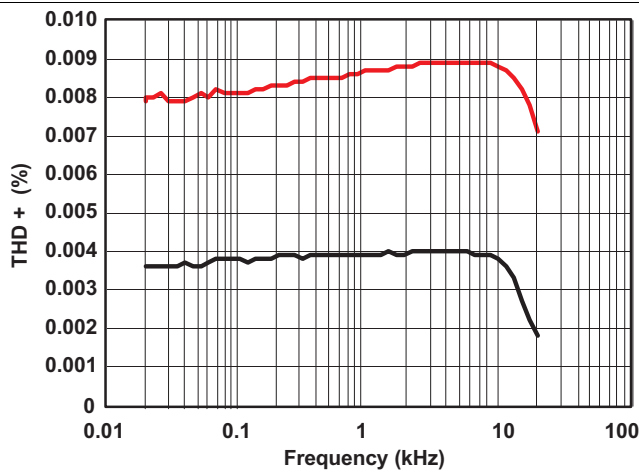

Figure 11. Total Harmonic Distortion vs Frequency

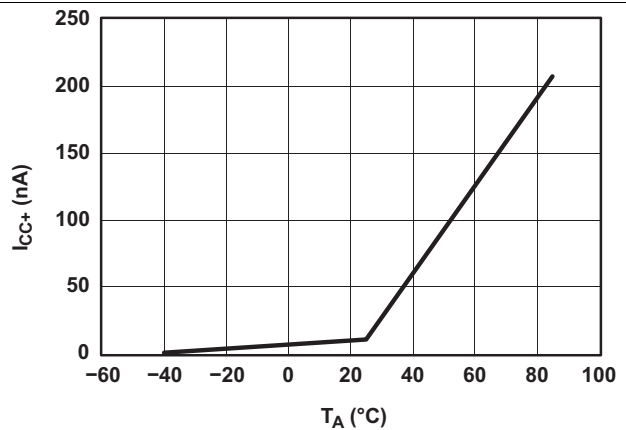

Figure 12. Power-Supply Current vs Temperature ($V_+ = 5\text{ V}$)

7 Parameter Measurement Information

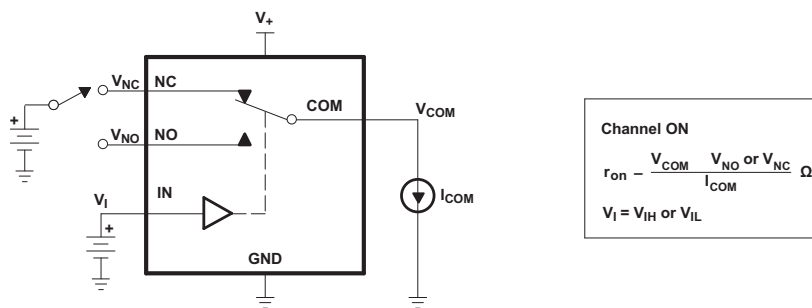

Figure 13. ON-State Resistance (r_{on})

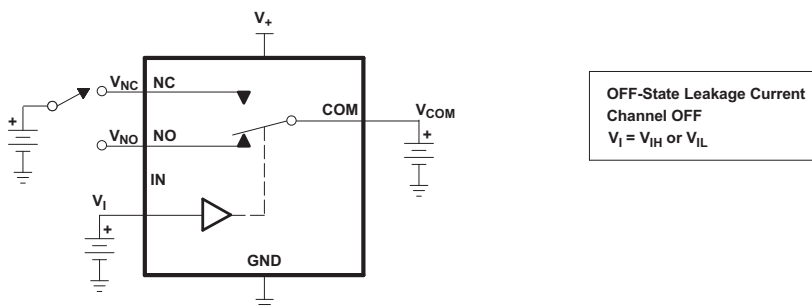

Figure 14. OFF-State Leakage Current ($I_{NC(OFF)}$, $I_{NO(OFF)}$, $I_{COM(OFF)}$, $I_{NC(PWROFF)}$, $I_{NO(PWROFF)}$, $I_{COM(PWROFF)}$)

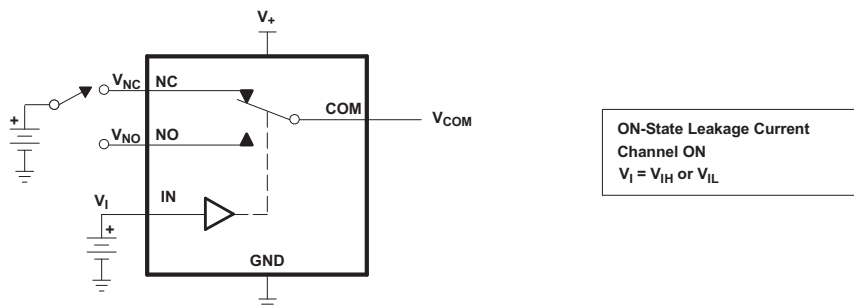

Figure 15. ON-State Leakage Current ($I_{COM(ON)}$, $I_{NC(ON)}$, $I_{NO(ON)}$)

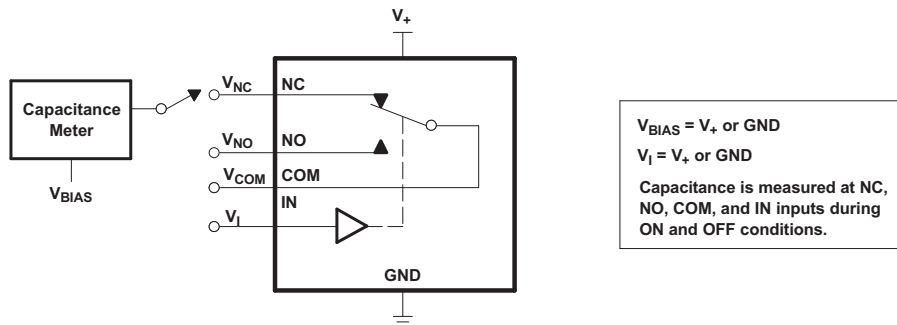
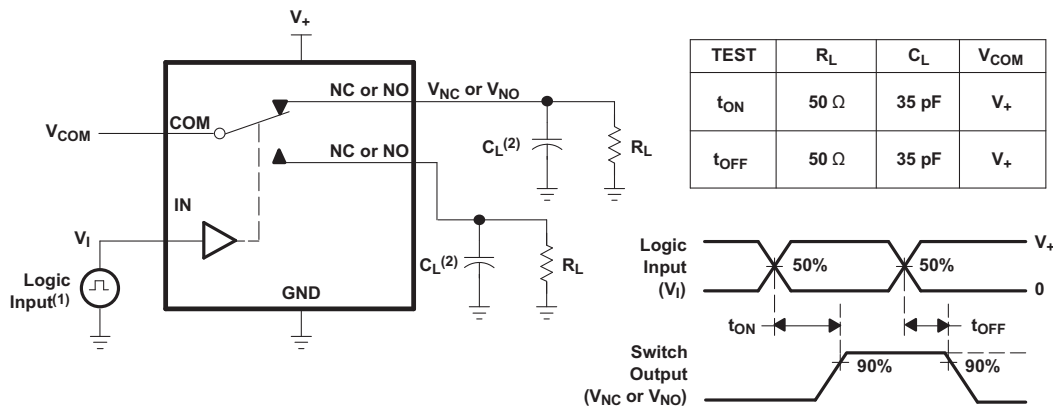

Figure 16. Capacitance (C_I , $C_{COM(ON)}$, $C_{NC(OFF)}$, $C_{NO(OFF)}$, $C_{NC(ON)}$, $C_{NO(ON)}$)

Parameter Measurement Information (continued)



- A. All input pulses are supplied by generators having the following characteristics: PRR ≤ 10 MHz, ZO = 50 Ω, tr < 5 ns, tf < 5 ns.
- B. CL includes probe and jig capacitance.

Figure 17. Turnon (tON) and Turnoff Time (tOFF)

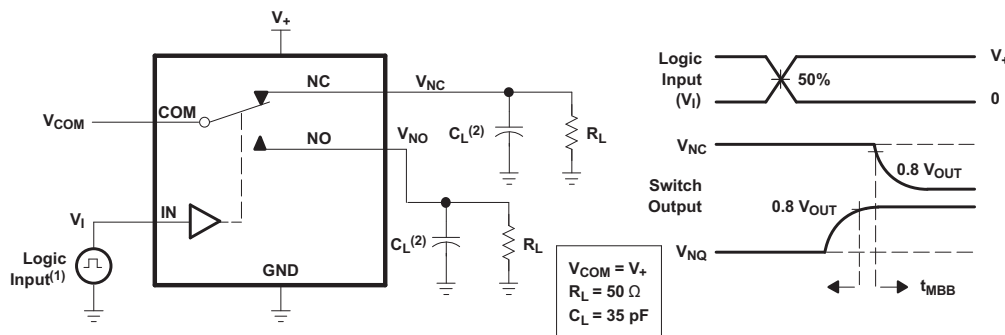

- A. All input pulses are supplied by generators having the following characteristics: PRR ≤ 10 MHz, ZO = 50 Ω, tr < 5 ns, tf < 5 ns.
- B. CL includes probe and jig capacitance.

Figure 18. Make-Before-Break Time (tMBB)

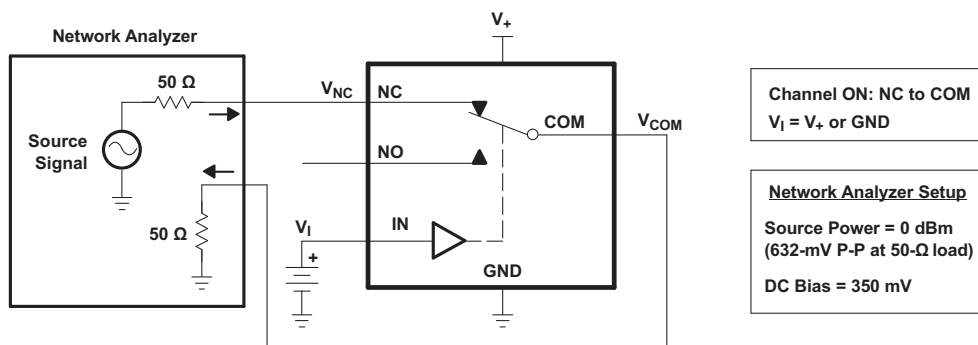

Figure 19. Bandwidth (BW)

Parameter Measurement Information (continued)

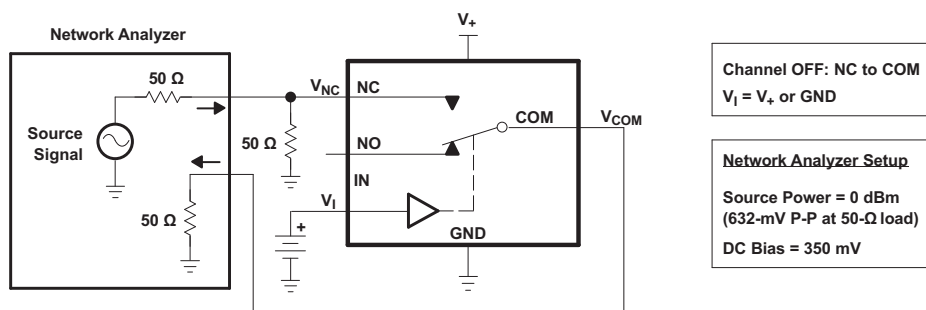

Figure 20. OFF Isolation (OISO)

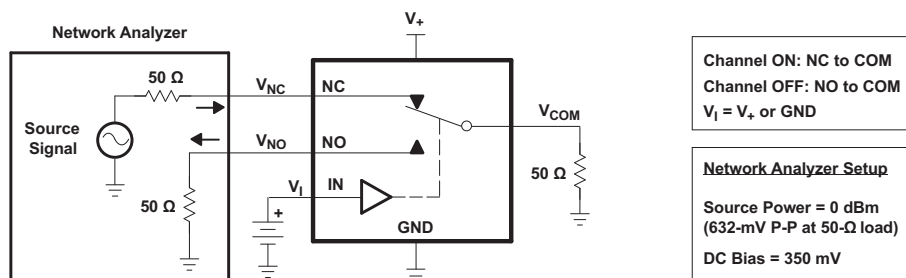
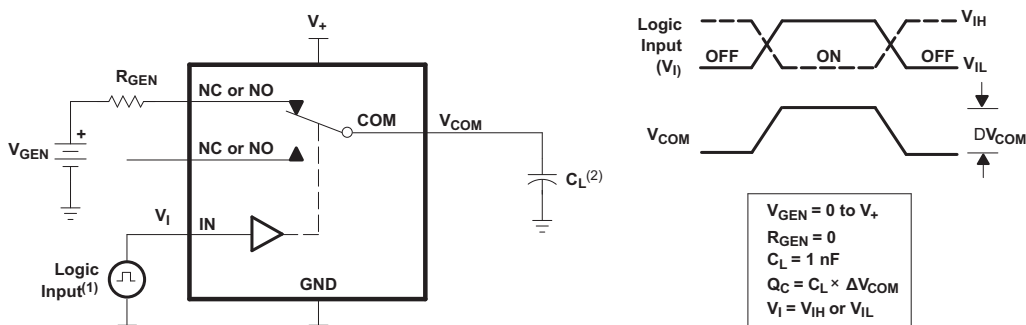

Figure 21. Crosstalk (X_{TALK})



- (1) All input pulses are supplied by generators having the following characteristics: PRR \leq 10 MHz, $Z_O = 50 \Omega$, $t_r < 5$ ns, $t_f < 5$ ns.
- A. C_L includes probe and jig capacitance.

Figure 22. Charge Injection (Q_C)

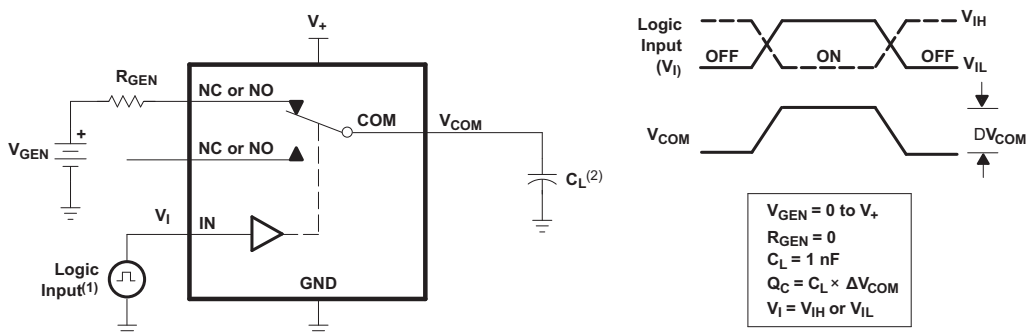

Figure 23. Total Harmonic Distortion (THD)

8 Detailed Description

8.1 Overview

The TS5A3160 is a single-pole-double-throw (SPDT) solid-state analog switch. The TS5A3160, like all analog switches, is bidirectional. When powered on, each COM pin is connected to the NC pin. For this device, NC stands for *normally closed* and NO stands for *normally open*. If IN is low, COM is connected to NC. If IN is high, COM is connected to NO.

The TS5A3160 is a make-before-break switch. This means that during switching, a connection is made before the existing connection is broken. During this brief period, the NC and NO pins are connected to each other.

8.2 Functional Block Diagram

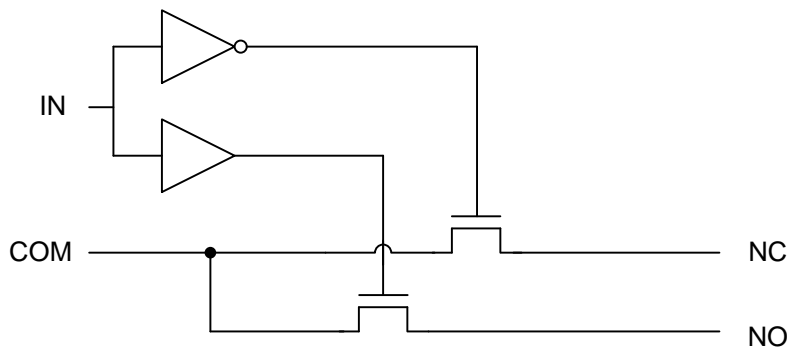

8.3 Feature Description

The low ON-state resistance, ON-state resistance matching, and charge injection in the TS5A3160 make this switch an excellent choice for analog signals that require minimal distortion. In addition, the low THD allows audio signals to be preserved more clearly as they pass through the device.

The 1.65-V to 5.5-V operation allows compatibility with more logic levels, and the bidirectional I/Os can pass analog signals from 0 V to V_+ with low distortion.

8.4 Device Functional Modes

Table 1 lists the functional modes for the TS5A3160.

Table 1. Function Table

IN	NC TO COM, COM TO NC	NO TO COM, COM TO NO
L	ON	OFF
H	OFF	ON

9 Application and Implementation

NOTE

Information in the following applications sections is not part of the TI component specification, and TI does not warrant its accuracy or completeness. TI's customers are responsible for determining suitability of components for their purposes. Customers should validate and test their design implementation to confirm system functionality.

9.1 Application Information

The TS5A3160 can be used in a variety of customer systems. The TS5A3160 can be used anywhere multiple analog or digital signals must be selected to pass across a single line.

9.2 Typical Application

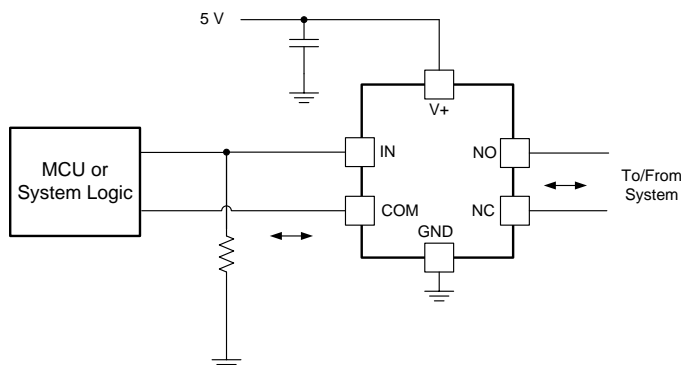

Figure 24. System Schematic for TS5A3160

9.2.1 Design Requirements

In this particular application, V_+ was 1.8 V, although V_+ is allowed to be any voltage specified in [Recommended Operating Conditions](#). A decoupling capacitor is recommended on the V_+ pin. See [Power Supply Recommendations](#) for more details.

9.2.2 Detailed Design Procedure

In this application, IN is, by default, pulled low to GND. Choose the resistor size based on the current driving strength of the GPIO, the desired power consumption, and the switching frequency (if applicable). If the GPIO is open-drain, use pullup resistors instead.

9.2.3 Application Curve

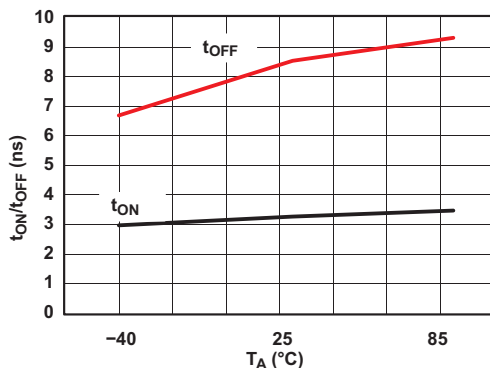

Figure 25. t_{ON} and t_{OFF} vs Temperature ($V_+ = 5$ V)

10 Power Supply Recommendations

The power supply can be any voltage between the minimum and maximum supply voltage rating located in the [Recommended Operating Conditions](#).

Each V_{CC} terminal should have a good bypass capacitor to prevent power disturbance. For devices with a single-supply, a 0.1- μF bypass capacitor is recommended. If there are multiple pins labeled V_{CC} , then a 0.01- μF or 0.022- μF capacitor is recommended for each V_{CC} because the V_{CC} pins will be tied together internally. For devices with dual-supply pins operating at different voltages, for example V_{CC} and V_{DD} , a 0.1- μF bypass capacitor is recommended for each supply pin. It is acceptable to parallel multiple bypass capacitors to reject different frequencies of noise. 0.1- μF and 1- μF capacitors are commonly used in parallel. The bypass capacitor should be installed as close to the power terminal as possible for best results.

11 Layout

11.1 Layout Guidelines

Reflections and matching are closely related to loop antenna theory, but different enough to warrant their own discussion. When a PCB trace turns a corner at a 90° angle, a reflection can occur. This is primarily due to the change of width of the trace. At the apex of the turn, the trace width is increased to 1.414 times its width. This upsets the transmission line characteristics, especially the distributed capacitance and self-inductance of the trace — resulting in the reflection. It is a given that not all PCB traces can be straight, and so they will have to turn corners. Below figure shows progressively better techniques of rounding corners. Only the last example maintains constant trace width and minimizes reflections.

Unused switch I/Os, such as NO, NC, and COM, can be left floating or tied to GND. However, the IN pin must be driven high or low. Due to partial transistor turnon when control inputs are at threshold levels, floating control inputs can cause increased I_{CC} or unknown switch selection states.

11.2 Layout Example

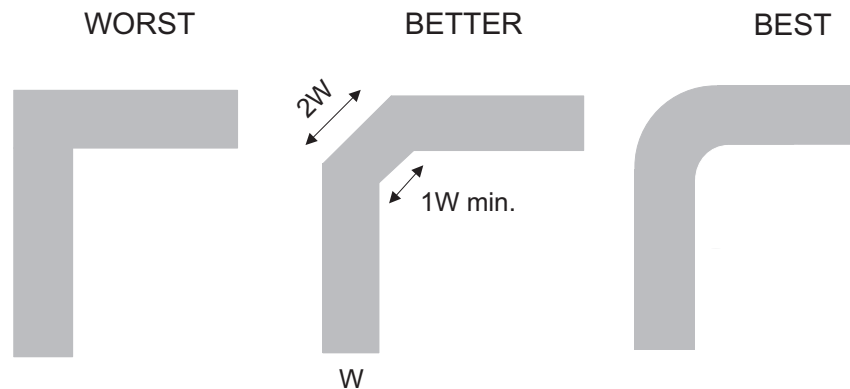

Figure 26. Trace Example

12 Device and Documentation Support

12.1 Device Support

12.1.1 Device Nomenclature

Table 2. Parameter Description

SYMBOL	DESCRIPTION
V_{COM}	Voltage at COM
V_{NC}	Voltage at NC
V_{NO}	Voltage at NO
r_{on}	Resistance between COM and NO ports when the channel is ON
r_{peak}	Peak on-state resistance over a specified voltage range
Δr_{on}	Difference of r_{on} between channels in a specific device
$r_{on(flat)}$	Difference between the maximum and minimum value of r_{on} in a channel over the specified range of conditions
$I_{NC(OFF)}$	Leakage current measured at the NC port, with the corresponding channel (NC to COM) in the OFF state under worst-case input and output conditions
$I_{NC(PWROFF)}$	Leakage current measured at the NC port during the power-off condition, $V_+ = 0$
$I_{NO(OFF)}$	Leakage current measured at the NO port, with the corresponding channel (NO to COM) in the OFF state
$I_{NO(PWROFF)}$	Leakage current measured at the NO port during the power-off condition, $V_+ = 0$
$I_{NC(ON)}$	Leakage current measured at the NC port, with the corresponding channel (NC to COM) in the ON state and the output (COM) open
$I_{NO(ON)}$	Leakage current measured at the NO port, with the corresponding channel (NO to COM) in the ON state and the output (COM) open
$I_{NO(OFF)}$	Leakage current measured at the NO port, with the corresponding channel (NO to COM) in the OFF state and the output (COM) open
$I_{NO(ON)}$	Leakage current measured at the NO port, with the corresponding channel (NO to COM) in the ON state and the output (COM) open
$I_{COM(OFF)}$	Leakage current measured at the COM port, with the corresponding channel (COM to NO) in the OFF state
$I_{COM(PWROFF)}$	Leakage current measured at the COM port during the power-off condition, $V_+ = 0$
$I_{COM(ON)}$	Leakage current measured at the COM port, with the corresponding channel (COM to NO) in the ON state and the output (NO) open
V_{IH}	Minimum input voltage for logic high for the control input (IN)
V_{IL}	Maximum input voltage for logic low for the control input (IN)
V_I	Voltage at the control input (IN)
I_{IH}, I_{IL}	Leakage current measured at the control input (IN)
t_{ON}	Turn-on time for the switch. This parameter is measured under the specified range of conditions and by the propagation delay between the digital control (IN) signal and analog output (COM or NO) signal when the switch is turning ON.
t_{OFF}	Turn-off time for the switch. This parameter is measured under the specified range of conditions and by the propagation delay between the digital control (IN) signal and analog output (COM or NO) signal when the switch is turning OFF.
t_{MBS}	Make-before-break time. This parameter is measured under the specified range of conditions and by the propagation delay between the output of two adjacent analog channels (NC and NO) when the control signal changes state.
Q_C	Charge injection is a measurement of unwanted signal coupling from the control (IN) input to the analog (NO or COM) output. This is measured in coulomb (C) and measured by the total charge induced due to switching of the control input. Charge injection, $Q_C = C_L \times \Delta V_{COM}$. C_L is the load capacitance and ΔV_{COM} is the change in analog output voltage.
$C_{NC(OFF)}$	Capacitance at the NC port when the corresponding channel (NC to COM) is OFF
$C_{NO(OFF)}$	Capacitance at the NO port when the corresponding channel (NO to COM) is OFF
$C_{NC(ON)}$	Capacitance at the NC port when the corresponding channel (NC to COM) is ON
$C_{NO(ON)}$	Capacitance at the NO port when the corresponding channel (NO to COM) is ON
$C_{COM(ON)}$	Capacitance at the COM port when the corresponding channel (COM to NO) is ON
C_I	Capacitance of IN
O_{ISO}	OFF isolation of the switch is a measurement of OFF-state switch impedance. This is measured in dB in a specific frequency, with the corresponding channel (NO to COM) in the OFF state.

Table 2. Parameter Description (continued)

SYMBOL	DESCRIPTION
X_{TALK}	Crosstalk is a measurement of unwanted signal coupling from an ON channel to an adjacent ON channel (NC1 to NC2). This is measured in a specific frequency and in dB.
BW	Bandwidth of the switch. This is the frequency in which the gain of an ON channel is -3 dB below the DC gain.
THD	Total harmonic distortion is defined as the ratio of the root mean square (RMS) value of the second, third, and higher harmonics to the magnitude of fundamental harmonic.
I_+	Static power-supply current with the control (IN) pin at V_+ or GND

12.2 Documentation Support

12.2.1 Related Documentation

For related documentation, see the following:

- *Implications of Slow or Floating CMOS Inputs*, [SCBA004](#)

12.3 Community Resources

The following links connect to TI community resources. Linked contents are provided "AS IS" by the respective contributors. They do not constitute TI specifications and do not necessarily reflect TI's views; see TI's [Terms of Use](#).

TI E2E™ Online Community *TI's Engineer-to-Engineer (E2E) Community*. Created to foster collaboration among engineers. At e2e.ti.com, you can ask questions, share knowledge, explore ideas and help solve problems with fellow engineers.

Design Support *TI's Design Support* Quickly find helpful E2E forums along with design support tools and contact information for technical support.

12.4 Trademarks

E2E is a trademark of Texas Instruments.

All other trademarks are the property of their respective owners.

12.5 Electrostatic Discharge Caution



These devices have limited built-in ESD protection. The leads should be shorted together or the device placed in conductive foam during storage or handling to prevent electrostatic damage to the MOS gates.

12.6 Glossary

[SLYZ022](#) — *TI Glossary*.

This glossary lists and explains terms, acronyms, and definitions.

13 Mechanical, Packaging, and Orderable Information

The following pages include mechanical, packaging, and orderable information. This information is the most current data available for the designated devices. This data is subject to change without notice and revision of this document. For browser-based versions of this data sheet, refer to the left-hand navigation.

PACKAGING INFORMATION

Orderable Device	Status (1)	Package Type	Package Drawing	Pins	Package Qty	Eco Plan (2)	Lead/Ball Finish (6)	MSL Peak Temp (3)	Op Temp (°C)	Device Marking (4/5)	Samples
TS5A3160DBVR	ACTIVE	SOT-23	DBV	6	3000	Green (RoHS & no Sb/Br)	CU NIPDAU	Level-1-260C-UNLIM	-40 to 85	JAKR JAKH	Samples
TS5A3160DBVT	ACTIVE	SOT-23	DBV	6	250	Green (RoHS & no Sb/Br)	CU NIPDAU	Level-1-260C-UNLIM	-40 to 85	JAKR JAKH	Samples
TS5A3160DBVTE4	ACTIVE	SOT-23	DBV	6	250	Green (RoHS & no Sb/Br)	CU NIPDAU	Level-1-260C-UNLIM	-40 to 85	JAKR JAKH	Samples
TS5A3160DBVTG4	ACTIVE	SOT-23	DBV	6	250	Green (RoHS & no Sb/Br)	CU NIPDAU	Level-1-260C-UNLIM	-40 to 85	JAKR JAKH	Samples
TS5A3160DCKJ	ACTIVE	SC70	DCK	6	10000	Green (RoHS & no Sb/Br)	CU NIPDAU	Level-1-260C-UNLIM	-40 to 85	(JKK ~ JKR) JKH	Samples
TS5A3160DCKR	ACTIVE	SC70	DCK	6	3000	Green (RoHS & no Sb/Br)	CU NIPDAU	Level-1-260C-UNLIM	-40 to 85	(JKK ~ JKR) JKH	Samples
TS5A3160DCKRG4	ACTIVE	SC70	DCK	6	3000	Green (RoHS & no Sb/Br)	CU NIPDAU	Level-1-260C-UNLIM	-40 to 85	(JKK ~ JKR) JKH	Samples
TS5A3160DCKT	ACTIVE	SC70	DCK	6	250	Green (RoHS & no Sb/Br)	CU NIPDAU	Level-1-260C-UNLIM	-40 to 85	(JKK ~ JKR) JKH	Samples
TS5A3160DCKTG4	ACTIVE	SC70	DCK	6	250	Green (RoHS & no Sb/Br)	CU NIPDAU	Level-1-260C-UNLIM	-40 to 85	(JKK ~ JKR) JKH	Samples

(1) The marketing status values are defined as follows:

ACTIVE: Product device recommended for new designs.

LIFEBUY: TI has announced that the device will be discontinued, and a lifetime-buy period is in effect.

NRND: Not recommended for new designs. Device is in production to support existing customers, but TI does not recommend using this part in a new design.

PREVIEW: Device has been announced but is not in production. Samples may or may not be available.

OBSOLETE: TI has discontinued the production of the device.

(2) Eco Plan - The planned eco-friendly classification: Pb-Free (RoHS), Pb-Free (RoHS Exempt), or Green (RoHS & no Sb/Br) - please check <http://www.ti.com/productcontent> for the latest availability information and additional product content details.

TBD: The Pb-Free/Green conversion plan has not been defined.

Pb-Free (RoHS): TI's terms "Lead-Free" or "Pb-Free" mean semiconductor products that are compatible with the current RoHS requirements for all 6 substances, including the requirement that lead not exceed 0.1% by weight in homogeneous materials. Where designed to be soldered at high temperatures, TI Pb-Free products are suitable for use in specified lead-free processes.

Pb-Free (RoHS Exempt): This component has a RoHS exemption for either 1) lead-based flip-chip solder bumps used between the die and package, or 2) lead-based die adhesive used between the die and leadframe. The component is otherwise considered Pb-Free (RoHS compatible) as defined above.

Green (RoHS & no Sb/Br): TI defines "Green" to mean Pb-Free (RoHS compatible), and free of Bromine (Br) and Antimony (Sb) based flame retardants (Br or Sb do not exceed 0.1% by weight in homogeneous material)

- (3) MSL, Peak Temp. - The Moisture Sensitivity Level rating according to the JEDEC industry standard classifications, and peak solder temperature.
- (4) There may be additional marking, which relates to the logo, the lot trace code information, or the environmental category on the device.
- (5) Multiple Device Markings will be inside parentheses. Only one Device Marking contained in parentheses and separated by a "~" will appear on a device. If a line is indented then it is a continuation of the previous line and the two combined represent the entire Device Marking for that device.
- (6) Lead/Ball Finish - Orderable Devices may have multiple material finish options. Finish options are separated by a vertical ruled line. Lead/Ball Finish values may wrap to two lines if the finish value exceeds the maximum column width.

Important Information and Disclaimer:The information provided on this page represents TI's knowledge and belief as of the date that it is provided. TI bases its knowledge and belief on information provided by third parties, and makes no representation or warranty as to the accuracy of such information. Efforts are underway to better integrate information from third parties. TI has taken and continues to take reasonable steps to provide representative and accurate information but may not have conducted destructive testing or chemical analysis on incoming materials and chemicals. TI and TI suppliers consider certain information to be proprietary, and thus CAS numbers and other limited information may not be available for release.

In no event shall TI's liability arising out of such information exceed the total purchase price of the TI part(s) at issue in this document sold by TI to Customer on an annual basis.

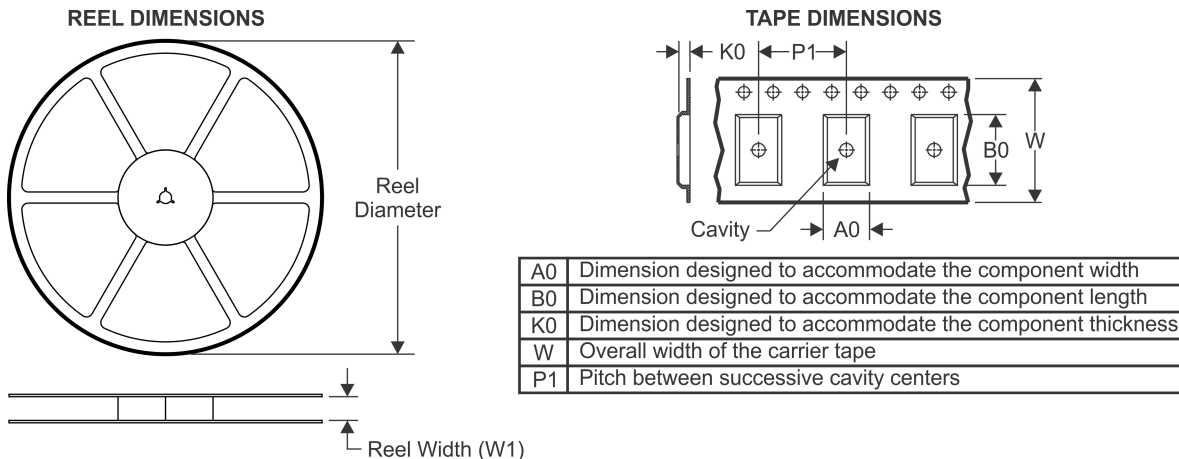
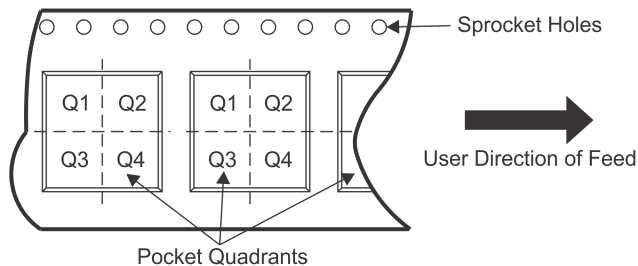
TAPE AND REEL INFORMATION

QUADRANT ASSIGNMENTS FOR PIN 1 ORIENTATION IN TAPE

*All dimensions are nominal

Device	Package Type	Package Drawing	Pins	SPQ	Reel Diameter (mm)	Reel Width W1 (mm)	A0 (mm)	B0 (mm)	K0 (mm)	P1 (mm)	W (mm)	Pin1 Quadrant
TS5A3160DBVR	SOT-23	DBV	6	3000	180.0	8.4	3.23	3.17	1.37	4.0	8.0	Q3
TS5A3160DBVT	SOT-23	DBV	6	250	180.0	8.4	3.23	3.17	1.37	4.0	8.0	Q3
TS5A3160DCKJ	SC70	DCK	6	10000	330.0	8.4	2.3	2.55	1.2	4.0	8.0	Q3
TS5A3160DCKR	SC70	DCK	6	3000	180.0	9.2	2.3	2.55	1.2	4.0	8.0	Q3
TS5A3160DCKT	SC70	DCK	6	250	180.0	9.2	2.3	2.55	1.2	4.0	8.0	Q3

TAPE AND REEL BOX DIMENSIONS



*All dimensions are nominal

Device	Package Type	Package Drawing	Pins	SPQ	Length (mm)	Width (mm)	Height (mm)
TS5A3160DBVR	SOT-23	DBV	6	3000	202.0	201.0	28.0
TS5A3160DBVT	SOT-23	DBV	6	250	202.0	201.0	28.0
TS5A3160DCKJ	SC70	DCK	6	10000	182.0	182.0	20.0
TS5A3160DCKR	SC70	DCK	6	3000	205.0	200.0	33.0
TS5A3160DCKT	SC70	DCK	6	250	205.0	200.0	33.0

MECHANICAL DATA

DBV (R-PDSO-G6)

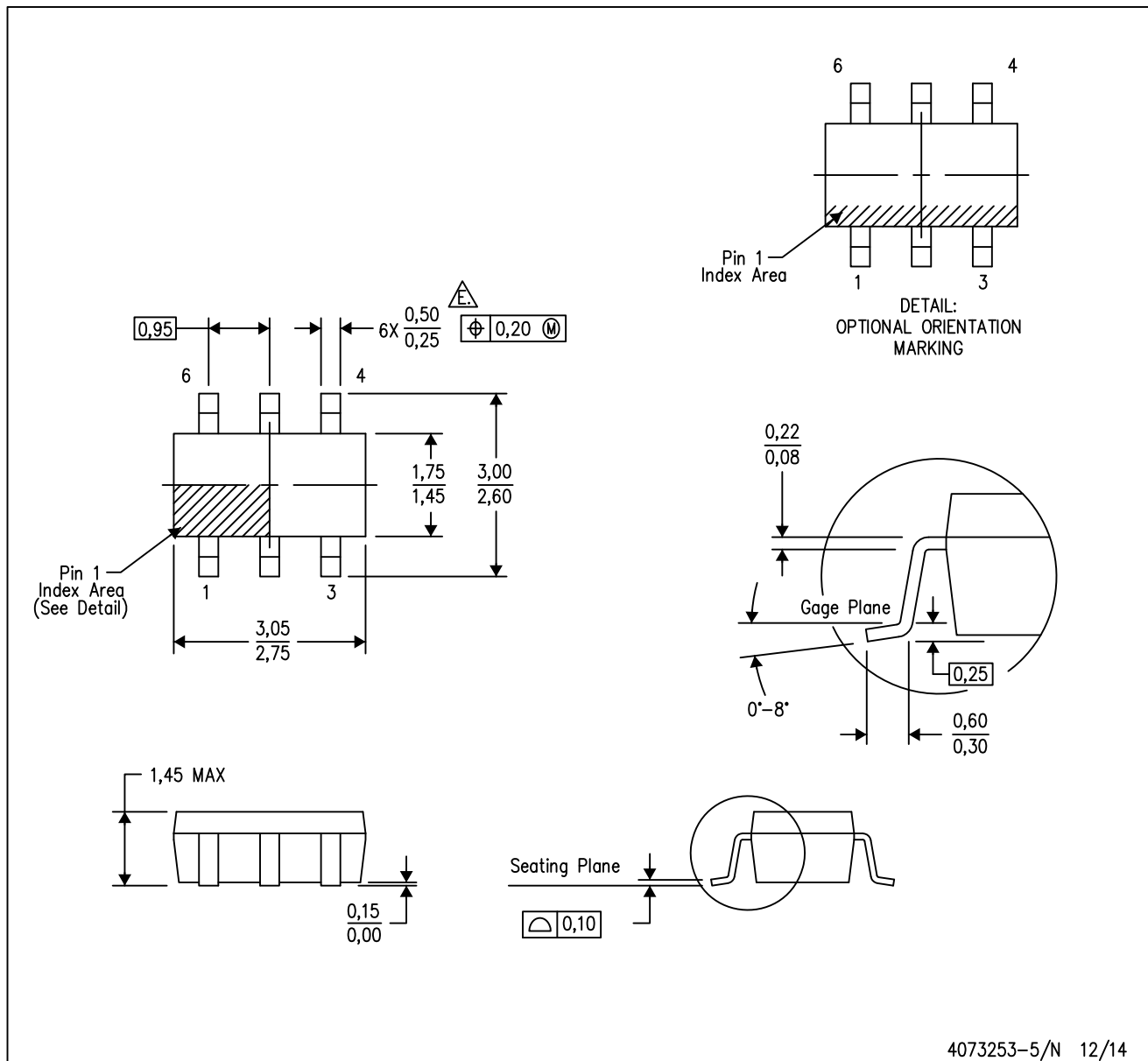
PLASTIC SMALL-OUTLINE PACKAGE



- NOTES:
- All linear dimensions are in millimeters.
 - This drawing is subject to change without notice.
 - Body dimensions do not include mold flash or protrusion. Mold flash and protrusion shall not exceed 0.15 per side.
 - Leads 1,2,3 may be wider than leads 4,5,6 for package orientation.
- ⚠ Falls within JEDEC MO-178 Variation AB, except minimum lead width.

DBV (R-PDSO-G6)

PLASTIC SMALL OUTLINE

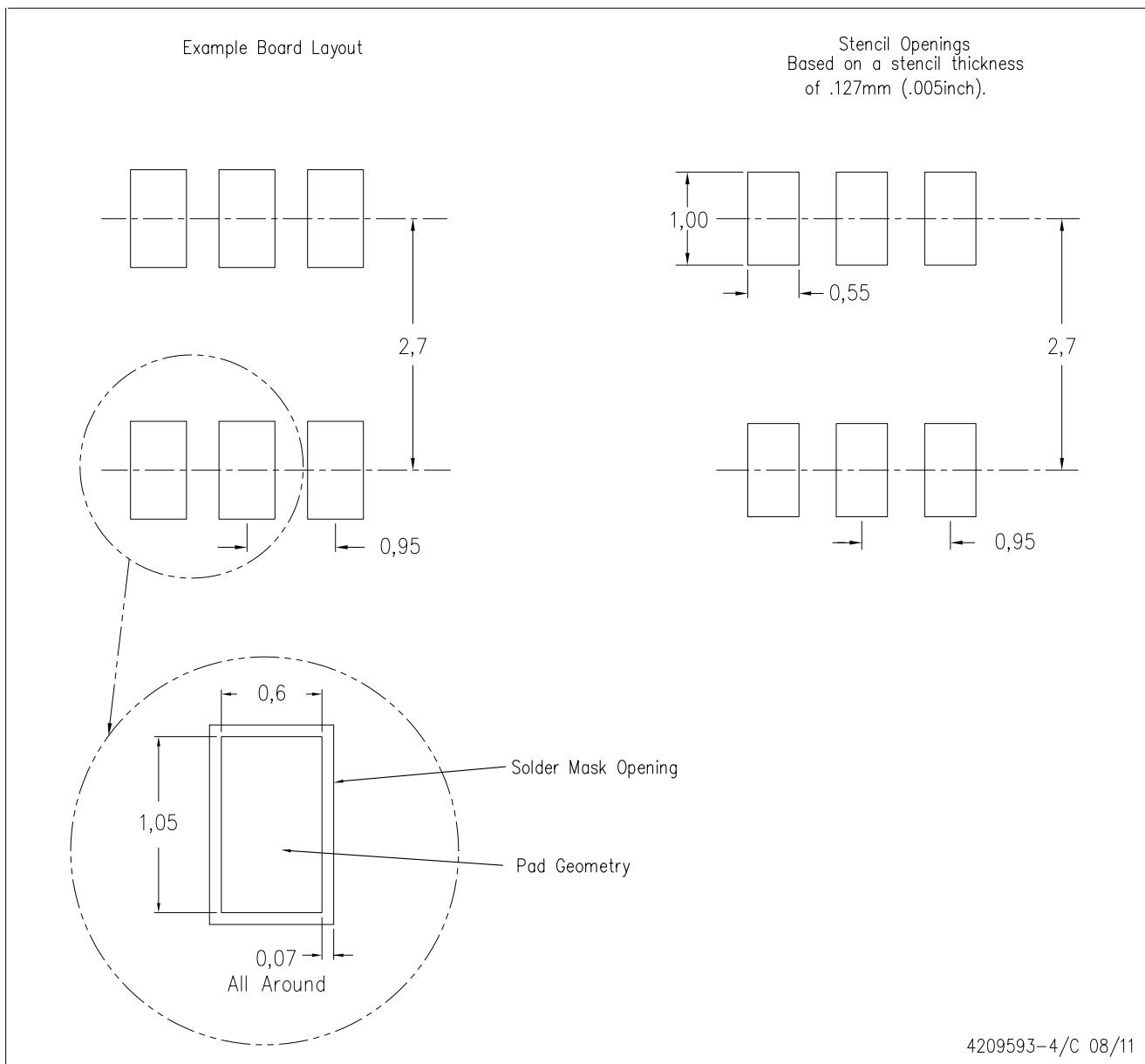

- NOTES:
- A. All linear dimensions are in millimeters.
 - B. This drawing is subject to change without notice.
 - C. Customers should place a note on the circuit board fabrication drawing not to alter the center solder mask defined pad.
 - D. Publication IPC-7351 is recommended for alternate designs.
 - E. Laser cutting apertures with trapezoidal walls and also rounding corners will offer better paste release. Customers should contact their board assembly site for stencil design recommendations. Example stencil design based on a 50% volumetric metal load solder paste. Refer to IPC-7525 for other stencil recommendations.

DCK (R-PDSO-G6)

PLASTIC SMALL-OUTLINE PACKAGE

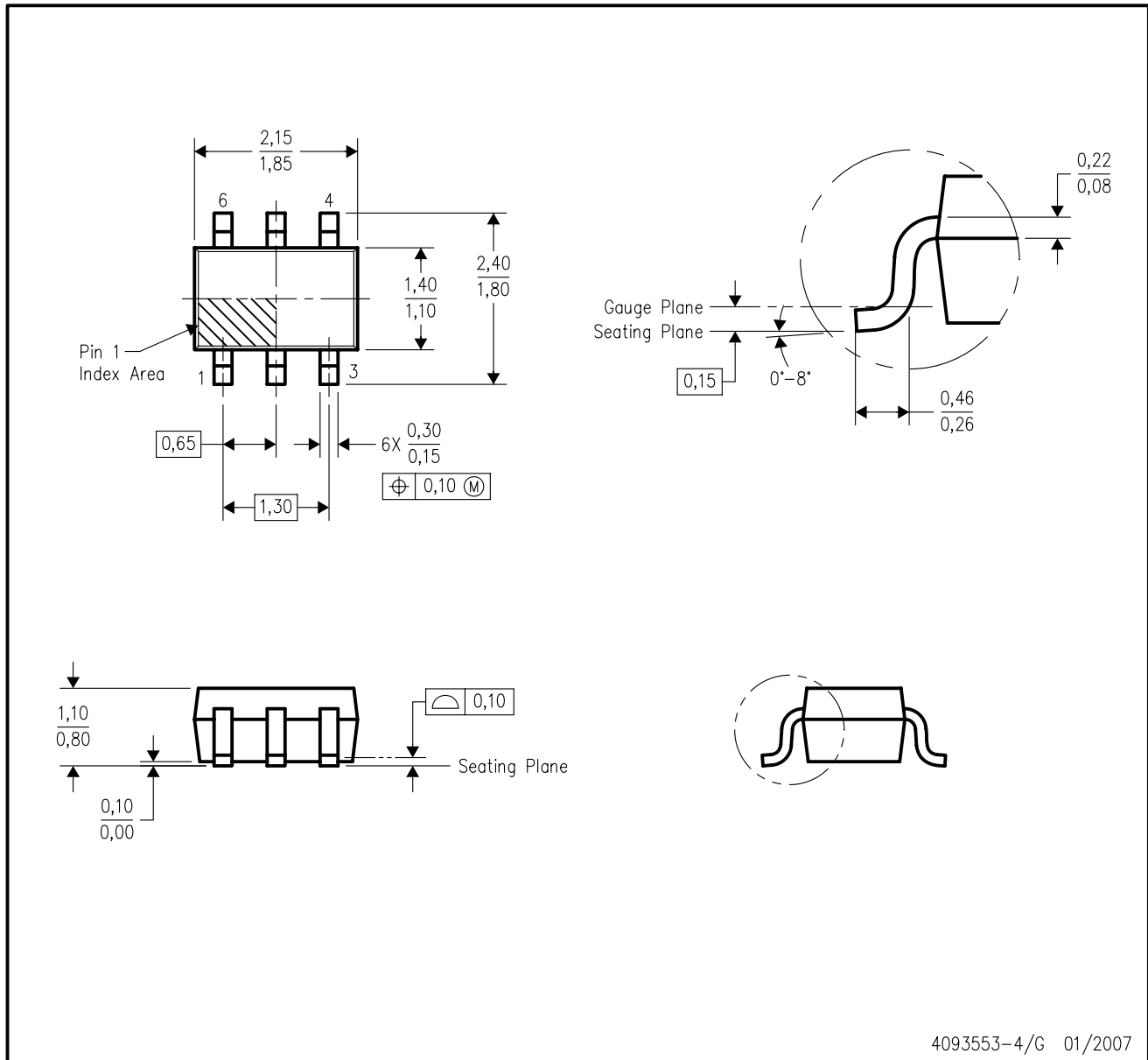

- NOTES:
- A. All linear dimensions are in millimeters.
 - B. This drawing is subject to change without notice.
 - C. Body dimensions do not include mold flash or protrusion. Mold flash and protrusion shall not exceed 0.15 per side.
 - D. Falls within JEDEC MO-203 variation AB.

DCK (R-PDSO-G6)

PLASTIC SMALL OUTLINE

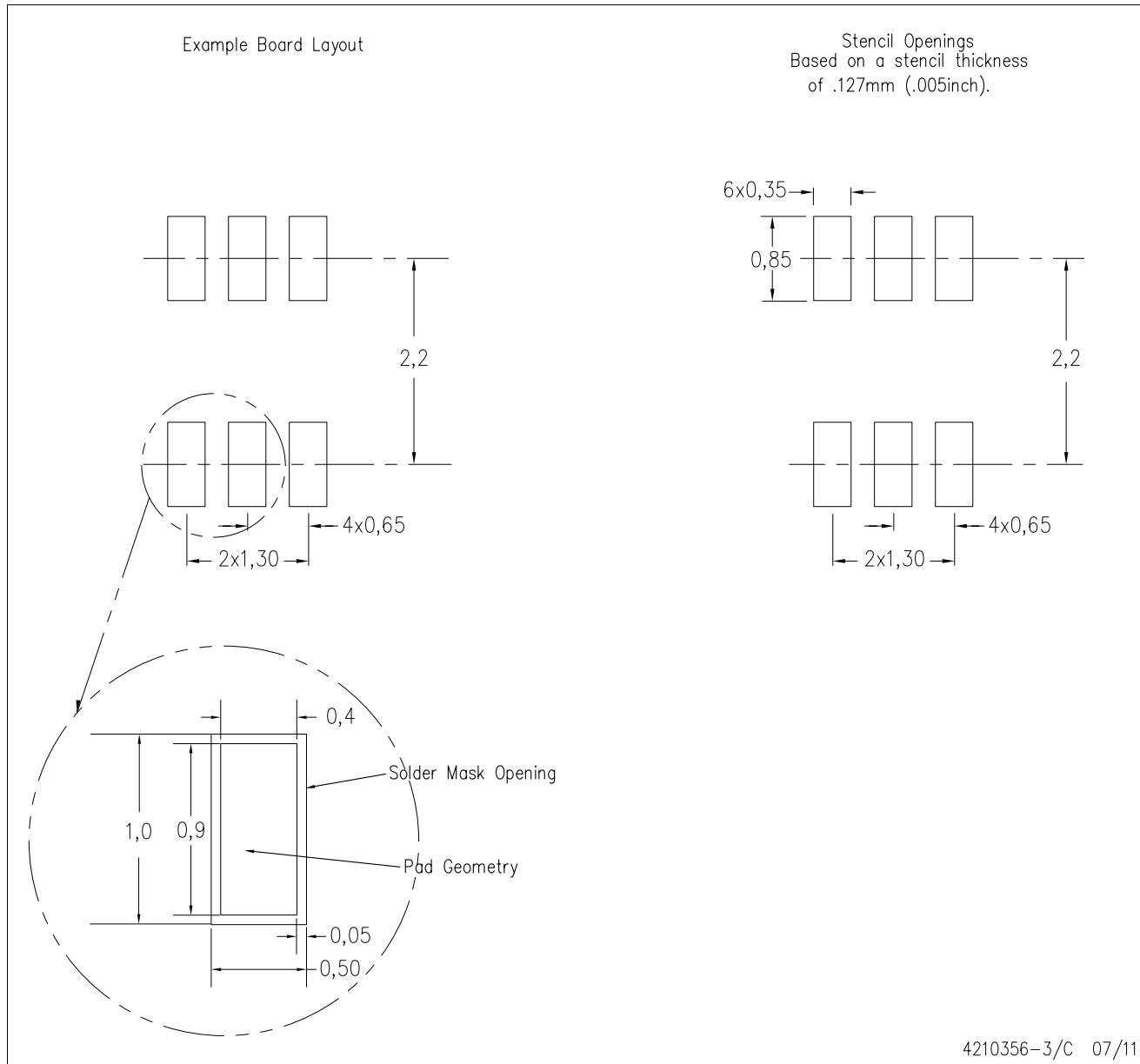

- NOTES:
- A. All linear dimensions are in millimeters.
 - B. This drawing is subject to change without notice.
 - C. Customers should place a note on the circuit board fabrication drawing not to alter the center solder mask defined pad.
 - D. Publication IPC-7351 is recommended for alternate designs.
 - E. Laser cutting apertures with trapezoidal walls and also rounding corners will offer better paste release. Customers should contact their board assembly site for stencil design recommendations. Example stencil design based on a 50% volumetric metal load solder paste. Refer to IPC-7525 for other stencil recommendations.

IMPORTANT NOTICE

Texas Instruments Incorporated and its subsidiaries (TI) reserve the right to make corrections, enhancements, improvements and other changes to its semiconductor products and services per JESD46, latest issue, and to discontinue any product or service per JESD48, latest issue. Buyers should obtain the latest relevant information before placing orders and should verify that such information is current and complete. All semiconductor products (also referred to herein as "components") are sold subject to TI's terms and conditions of sale supplied at the time of order acknowledgment.

TI warrants performance of its components to the specifications applicable at the time of sale, in accordance with the warranty in TI's terms and conditions of sale of semiconductor products. Testing and other quality control techniques are used to the extent TI deems necessary to support this warranty. Except where mandated by applicable law, testing of all parameters of each component is not necessarily performed.

TI assumes no liability for applications assistance or the design of Buyers' products. Buyers are responsible for their products and applications using TI components. To minimize the risks associated with Buyers' products and applications, Buyers should provide adequate design and operating safeguards.

TI does not warrant or represent that any license, either express or implied, is granted under any patent right, copyright, mask work right, or other intellectual property right relating to any combination, machine, or process in which TI components or services are used. Information published by TI regarding third-party products or services does not constitute a license to use such products or services or a warranty or endorsement thereof. Use of such information may require a license from a third party under the patents or other intellectual property of the third party, or a license from TI under the patents or other intellectual property of TI.

Reproduction of significant portions of TI information in TI data books or data sheets is permissible only if reproduction is without alteration and is accompanied by all associated warranties, conditions, limitations, and notices. TI is not responsible or liable for such altered documentation. Information of third parties may be subject to additional restrictions.

Resale of TI components or services with statements different from or beyond the parameters stated by TI for that component or service voids all express and any implied warranties for the associated TI component or service and is an unfair and deceptive business practice. TI is not responsible or liable for any such statements.

Buyer acknowledges and agrees that it is solely responsible for compliance with all legal, regulatory and safety-related requirements concerning its products, and any use of TI components in its applications, notwithstanding any applications-related information or support that may be provided by TI. Buyer represents and agrees that it has all the necessary expertise to create and implement safeguards which anticipate dangerous consequences of failures, monitor failures and their consequences, lessen the likelihood of failures that might cause harm and take appropriate remedial actions. Buyer will fully indemnify TI and its representatives against any damages arising out of the use of any TI components in safety-critical applications.

In some cases, TI components may be promoted specifically to facilitate safety-related applications. With such components, TI's goal is to help enable customers to design and create their own end-product solutions that meet applicable functional safety standards and requirements. Nonetheless, such components are subject to these terms.

No TI components are authorized for use in FDA Class III (or similar life-critical medical equipment) unless authorized officers of the parties have executed a special agreement specifically governing such use.

Only those TI components which TI has specifically designated as military grade or "enhanced plastic" are designed and intended for use in military/aerospace applications or environments. Buyer acknowledges and agrees that any military or aerospace use of TI components which have **not** been so designated is solely at the Buyer's risk, and that Buyer is solely responsible for compliance with all legal and regulatory requirements in connection with such use.

TI has specifically designated certain components as meeting ISO/TS16949 requirements, mainly for automotive use. In any case of use of non-designated products, TI will not be responsible for any failure to meet ISO/TS16949.

Products

Audio	www.ti.com/audio
Amplifiers	amplifier.ti.com
Data Converters	dataconverter.ti.com
DLP® Products	www.dlp.com
DSP	dsp.ti.com
Clocks and Timers	www.ti.com/clocks
Interface	interface.ti.com
Logic	logic.ti.com
Power Mgmt	power.ti.com
Microcontrollers	microcontroller.ti.com
RFID	www.ti-rfid.com
OMAP Applications Processors	www.ti.com/omap
Wireless Connectivity	www.ti.com/wirelessconnectivity

Applications

Automotive and Transportation	www.ti.com/automotive
Communications and Telecom	www.ti.com/communications
Computers and Peripherals	www.ti.com/computers
Consumer Electronics	www.ti.com/consumer-apps
Energy and Lighting	www.ti.com/energy
Industrial	www.ti.com/industrial
Medical	www.ti.com/medical
Security	www.ti.com/security
Space, Avionics and Defense	www.ti.com/space-avionics-defense
Video and Imaging	www.ti.com/video

TI E2E Community

e2e.ti.com