

# TS5L100

## QUAD SPDT WIDE-BANDWIDTH LAN SWITCH WITH LOW ON-STATE RESISTANCE

SCDS163A – MAY 2004 – REVISED MAY 2004

- Wide Bandwidth (BW = 300 MHz Min)
- Low Differential Crosstalk ( $X_{TALK} = -60$  dB Typ)
- Low Power Consumption ( $I_{CC} = 3$   $\mu$ A Max)
- Bidirectional Data Flow, With Near-Zero Propagation Delay
- Low ON-State Resistance ( $r_{ON} = 3$   $\Omega$  Typ)
- $V_{CC}$  Operating Range From 6 V to 6.5 V
- $I_{off}$  Supports Partial-Power-Down Mode Operation
- Data and Control Inputs Provide Undershoot Clamp Diode
- Latch-Up Performance Exceeds 100 mA Per JESD 78, Class II
- ESD Performance Tested Per JESD 22
  - 2000-V Human-Body Model (A114-B, Class II)
  - 1000-V Charged-Device Model (C101)
- Suitable for Both 10 Base-T/100 Base-T Signaling

D OR DBQ PACKAGE  
(TOP VIEW)

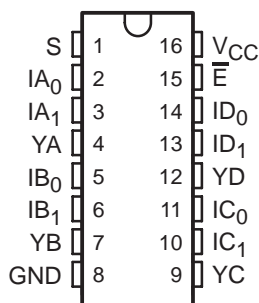

RGY PACKAGE  
(TOP VIEW)

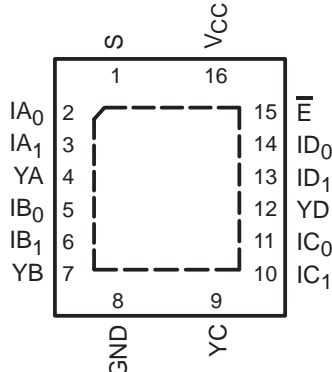

PW PACKAGE  
(TOP VIEW)

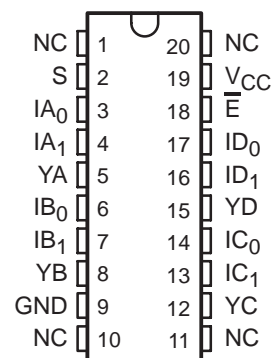

NC – No internal connection

### description/ordering information

The TI TS5L100 LAN switch is a 4-bit 1-of-2 multiplexer/demultiplexer with a single switch-enable ( $\bar{E}$ ) input. When  $\bar{E}$  is low, the switch is enabled and the I port is connected to the Y port. When  $\bar{E}$  is high, the switch is disabled and the high-impedance state exists between the I and Y ports. The select (S) input controls the data path of the multiplexer/demultiplexer.

### ORDERING INFORMATION

$T_A$	PACKAGE†		ORDERABLE PART NUMBER	TOP-SIDE MARKING
0°C to 70°C	QFN – RGY	Tape and reel	TS5L100RGYR	TG100
		Tube	TS5L100D	TS5L100
	SOIC – D	Tape and reel	TS5L100DR	
		SSOP (QSOP) – DBQ	Tape and reel	TS5L100DBQR
	TSSOP – PW	Tube	TS5L100PW	TG100
		Tape and reel	TS5L100PWR	

† Package drawings, standard packing quantities, thermal data, symbolization, and PCB design guidelines are available at [www.ti.com/sc/package](http://www.ti.com/sc/package).



Please be aware that an important notice concerning availability, standard warranty, and use in critical applications of Texas Instruments semiconductor products and disclaimers thereto appears at the end of this data sheet.

PRODUCTION DATA information is current as of publication date. Products conform to specifications per the terms of Texas Instruments standard warranty. Production processing does not necessarily include testing of all parameters.

**TEXAS  
INSTRUMENTS**

POST OFFICE BOX 655303 • DALLAS, TEXAS 75265

Copyright © 2004, Texas Instruments Incorporated

# TS5L100

## QUAD SPDT WIDE-BANDWIDTH LAN SWITCH WITH LOW ON-STATE RESISTANCE

SCDS163A – MAY 2004 – REVISED MAY 2004

### description/ordering information (continued)

This device can be used to replace mechanical relays in LAN applications. This device has low  $r_{on}$ , wide bandwidth, and low differential crosstalk, making it suitable for 10 Base-T, 100 Base-T, and various other LAN applications.

This device is fully specified for partial-power-down applications using  $I_{off}$ . The  $I_{off}$  feature ensures that damaging current will not backflow through the device when it is powered down. The device has isolation during power off.

To ensure the high-impedance state during power up or power down,  $\bar{E}$  should be tied to  $V_{CC}$  through a pullup resistor; the minimum value of the resistor is determined by the current-sinking capability of the driver.

FUNCTION TABLE

INPUTS		INPUT/OUTPUT YX	FUNCTION
$\bar{E}$	S		
L	L	$IX_0$	$YX = IX_0$
L	H	$IX_1$	$YX = IX_1$
H	X	Z	Disconnect

PIN DESCRIPTIONS

PIN NAME	DESCRIPTION
$IAn-IDn$	Data I/Os
S	Select input
$\bar{E}$	Enable input
$YA-YD$	Data I/Os



**TS5L100**  
**QUAD SPDT WIDE-BANDWIDTH LAN SWITCH**  
**WITH LOW ON-STATE RESISTANCE**

SCDS163A – MAY 2004 – REVISED MAY 2004

logic diagram (positive logic)

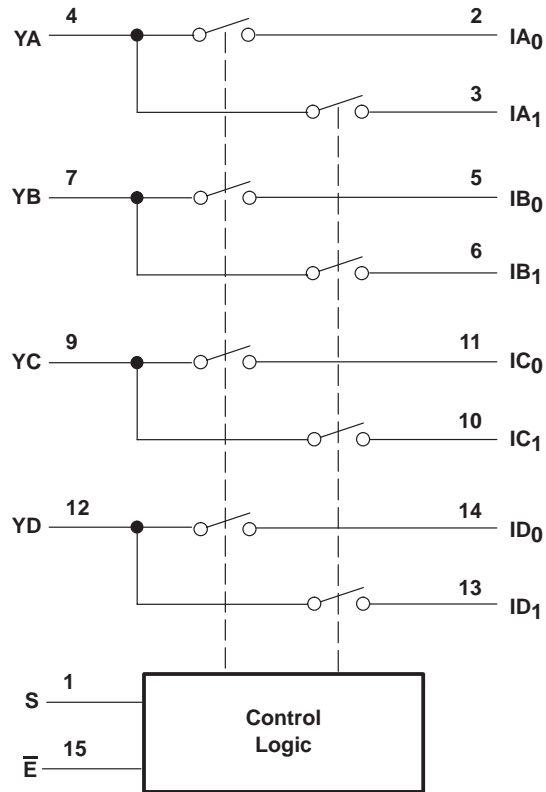

# TS5L100

## QUAD SPDT WIDE-BANDWIDTH LAN SWITCH WITH LOW ON-STATE RESISTANCE

SCDS163A – MAY 2004 – REVISED MAY 2004

### absolute maximum ratings over operating free-air temperature range (unless otherwise noted)†

Supply voltage range, $V_{CC}$	-0.5 V to 7 V
Control input voltage range, $V_{IN}$ (see Notes 1 and 2)	-0.5 V to 7 V
Switch I/O voltage range, $V_{I/O}$ (see Notes 1, 2, and 3)	-0.5 V to 7 V
Control input clamp current, $I_{IK}$ ( $V_{IN} < 0$ )	-50 mA
I/O port clamp current, $I_{I/OK}$ ( $V_{I/O} < 0$ )	-50 mA
ON-state switch current, $I_{I/O}$ (see Note 4)	$\pm 128$ mA
Continuous current through $V_{CC}$ or GND terminals	$\pm 100$ mA
Package thermal impedance, $\theta_{JA}$ (see Note 5): D package	73°C/W
(see Note 5): DBQ package	90°C/W
(see Note 5): PW package	83°C/W
(see Note 6): RGY package	39°C/W
Storage temperature range, $T_{stg}$	-65°C to 150°C

† Stresses beyond those listed under “absolute maximum ratings” may cause permanent damage to the device. These are stress ratings only, and functional operation of the device at these or any other conditions beyond those indicated under “recommended operating conditions” is not implied. Exposure to absolute-maximum-rated conditions for extended periods may affect device reliability.

- NOTES:
1. All voltages are with respect to ground, unless otherwise specified.
  2. The input and output voltage ratings may be exceeded if the input and output clamp-current ratings are observed.
  3.  $V_I$  and  $V_O$  are used to denote specific conditions for  $V_{I/O}$ .
  4.  $I_I$  and  $I_O$  are used to denote specific conditions for  $I_{I/O}$ .
  5. The package thermal impedance is calculated in accordance with JESD 51-7.
  6. The package thermal impedance is calculated in accordance with JESD 51-5.

### recommended operating conditions (see Note 7)

	MIN	MAX	UNIT
$V_{CC}$ Supply voltage	6	6.5	V
$V_{IH}$ High-level control input voltage ( $\bar{E}$ , S)	2.5	6.5	V
$V_{IL}$ Low-level control input voltage ( $\bar{E}$ , S)	0	0.8	V
$T_A$ Operating free-air temperature	0	70	°C

NOTE 7: All unused control inputs of the device must be held at  $V_{CC}$  or GND to ensure proper device operation. Refer to the TI application report, *Implications of Slow or Floating CMOS Inputs*, literature number SCBA004.



**TS5L100**  
**QUAD SPDT WIDE-BANDWIDTH LAN SWITCH**  
**WITH LOW ON-STATE RESISTANCE**

SCDS163A – MAY 2004 – REVISED MAY 2004

**electrical characteristics over recommended operating free-air temperature range,  $V_{CC} = 6\text{ V to }6.5\text{ V}$  (unless otherwise noted)**

PARAMETER		TEST CONDITIONS		MIN	TYP†	MAX	UNIT	
$V_{IK}$	$\bar{E}, S$	$V_{CC} = 6\text{ V},$	$I_{IN} = -18\text{ mA}$			-1.8	V	
$V_{hys}$	$\bar{E}, S$				150		mV	
$V_O$		$V_I = 4.5\text{ V},$	$\bar{E} = \text{low},$		3.7	4.06	V	
			$R_L = 100\ \Omega,$ see Figure 11					
$I_{IH}$	$\bar{E}, S$	$V_{CC} = 6.5\text{ V},$	$V_{IN} = V_{CC}$			$\pm 1$	$\mu\text{A}$	
$I_{IL}$	$\bar{E}, S$	$V_{CC} = 6.5\text{ V},$	$V_{IN} = \text{GND}$			$\pm 1$	$\mu\text{A}$	
$I_{OZ}^\ddagger$		$V_{CC} = 6.5\text{ V},$	$V_O = 0\text{ to }6.5\text{ V},$ $V_I = 0,$			$\pm 1$	$\mu\text{A}$	
			Switch OFF					
$I_{OS}^\S$		$V_{CC} = 6.5\text{ V},$	$V_O = 0\text{ to }0.5\text{ }V_{CC},$ $V_I = 0,$		50		mA	
			Switch ON					
$I_{off}$		$V_{CC} = 0,$	$V_O = 0\text{ to }6.5\text{ V},$			1	$\mu\text{A}$	
			$V_I = 0$					
$I_{CC}$		$V_{CC} = 6.5\text{ V},$	$I_{IO} = 0,$			3	$\mu\text{A}$	
			Switch ON or OFF					
$\Delta I_{CC}$	$\bar{E}, S$	$V_{CC} = 6.5\text{ V},$	One input at 3.4 V,			6	mA	
			Other inputs at $V_{CC}$ or GND					
$I_{CCD}$		$V_{CC} = 6.5\text{ V},$	I and Y ports open,			0.35	mA/ MHz	
			$V_{IN}$ input switching 50% duty cycle					
$C_{IN}$	$\bar{E}, S$	$f = 1\text{ MHz}$			3.5		pF	
$C_{OFF}$	I port	$V_I = 0,$	$f = 1\text{ MHz},$ Outputs open,	Switch OFF	4.5		pF	
	Y port				6.5			
$C_{ON}$		$V_I = 0,$	$f = 1\text{ MHz},$ Outputs open,	Switch ON	14		pF	
$r_{on}$	M1	$V_I = 4.5\text{ V},$	Switch ON,	$R_L = 100\ \Omega,$ see Figure 11	7.5	11.2	19	$\Omega$
	M2				2	3	6	
$\Delta r_{on}$		$V_I = 4.5\text{ V},$	Switch ON			1	2	$\Omega$

$V_I, V_O, I_I,$  and  $I_O$  refer to I/O pins.  $V_{IN}$  refers to the control inputs.

† All typical values are at  $V_{CC} = 6.2\text{ V}$  (unless otherwise noted),  $T_A = 25^\circ\text{C}$ .

‡ For I/O ports,  $I_{OZ}$  includes the input leakage current.

§ The  $I_{OS}$  test is applicable to only one ON channel at a time. The duration of this test is less than one second.

**switching characteristics over recommended operating free-air temperature range,  $V_{CC} = 6\text{ V to }6.5\text{ V}, R_L = 100\ \Omega, C_L = 35\text{ pF}$  (unless otherwise noted) (see Figure 7)**

PARAMETER	FROM (INPUT)	TO (OUTPUT)	MIN	MAX	UNIT
$t_{ON}$	S	Y		7	ns
$t_{OFF}$	S	Y		4	ns

† All typical values are at  $V_{CC} = 6.2\text{ V}$  (unless otherwise noted),  $T_A = 25^\circ\text{C}$ .

**dynamic characteristics over recommended operating free-air temperature range,  $V_{CC} = 6\text{ V to }6.5\text{ V}$  (unless otherwise noted)**

PARAMETER	TEST CONDITIONS			MIN	TYP†	MAX	UNIT
$X_{TALK}(\text{Diff})$	$R_L = 100\ \Omega,$	$f = 10\text{ MHz},$ see Figure 12,	$t_r = t_f = 2\text{ ns}$	-40	-60		dB
$X_{TALK}$	$R_L = 100\ \Omega,$	$f = 30\text{ MHz},$ see Figure 9			-50		dB
$O_{IRR}$	$R_L = 100\ \Omega,$	$f = 30\text{ MHz},$ see Figure 10			-40		dB
BW	$R_L = 100\ \Omega,$ see Figure 8				350		MHz

† All typical values are at  $V_{CC} = 6.2\text{ V}$  (unless otherwise noted),  $T_A = 25^\circ\text{C}$ .



# TS5L100 QUAD SPDT WIDE-BANDWIDTH LAN SWITCH WITH LOW ON-STATE RESISTANCE

SCDS163A – MAY 2004 – REVISED MAY 2004

## OPERATING CHARACTERISTICS

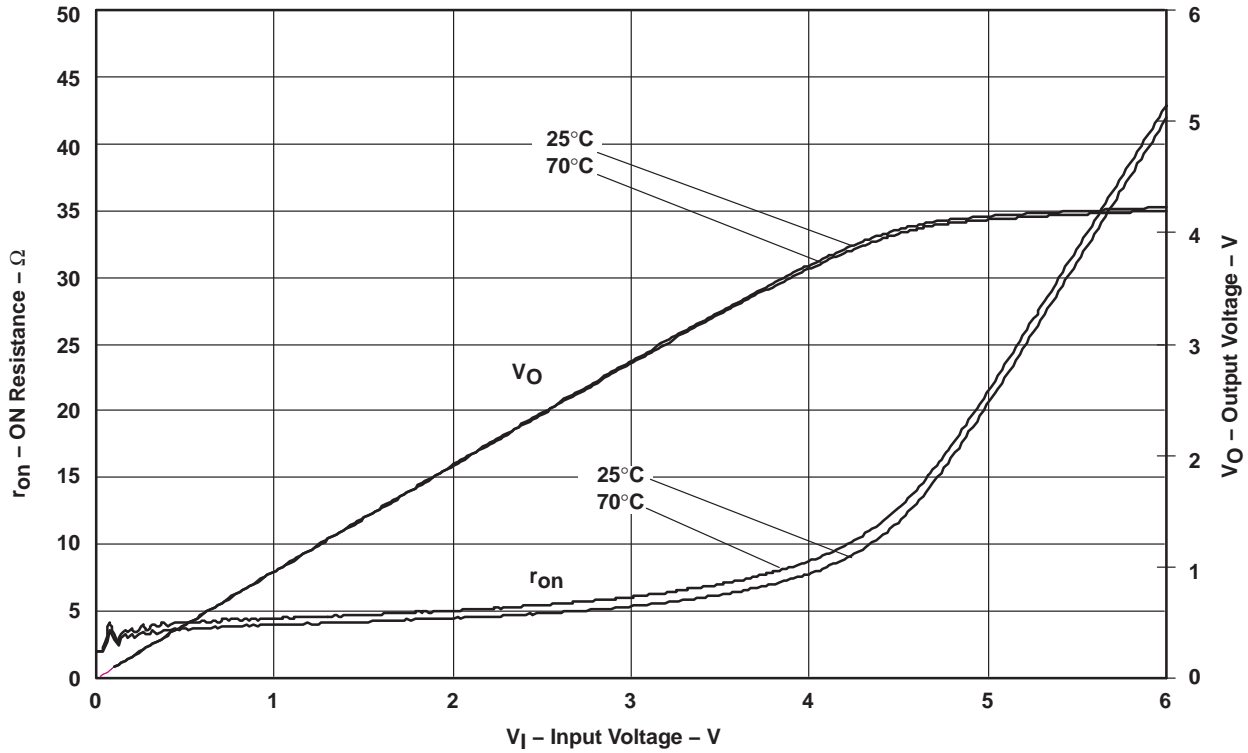

Figure 1.  $r_{on}$  and  $V_O$  vs  $V_I$  Over Temperature ( $V_{CC} = 6V$ )

OPERATING CHARACTERISTICS

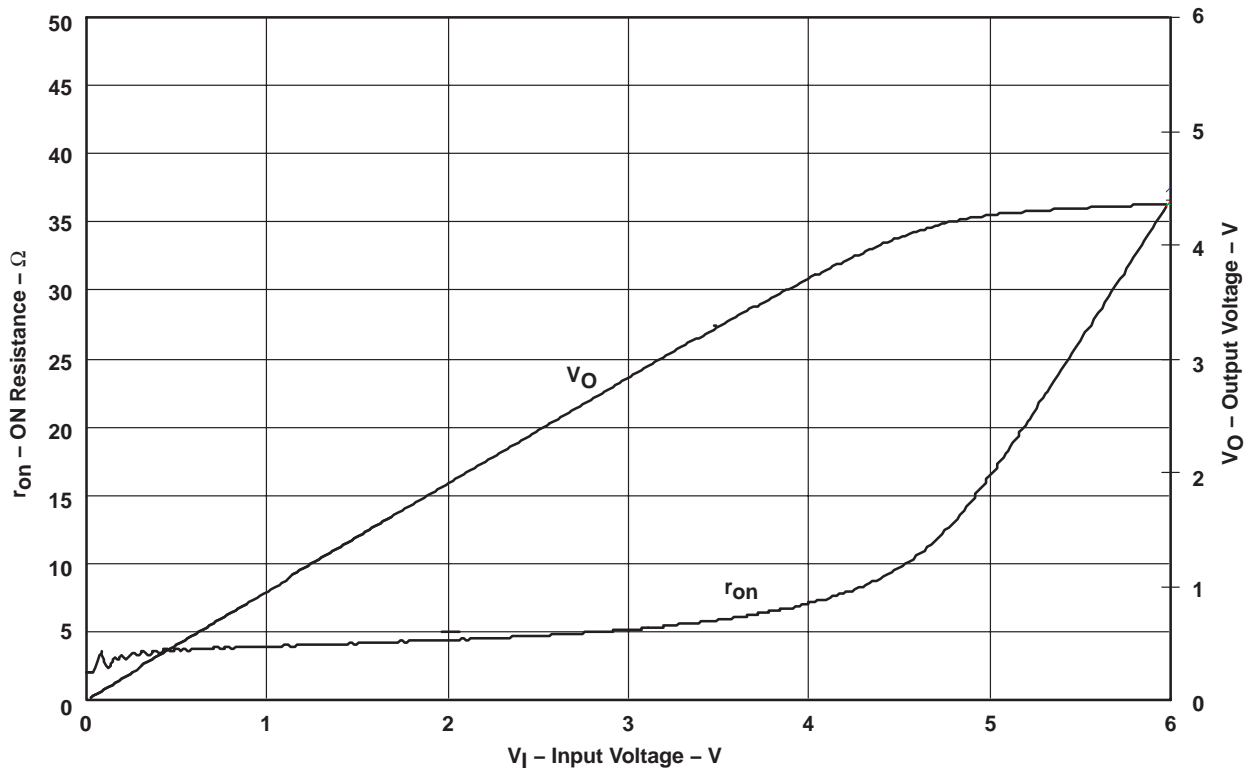
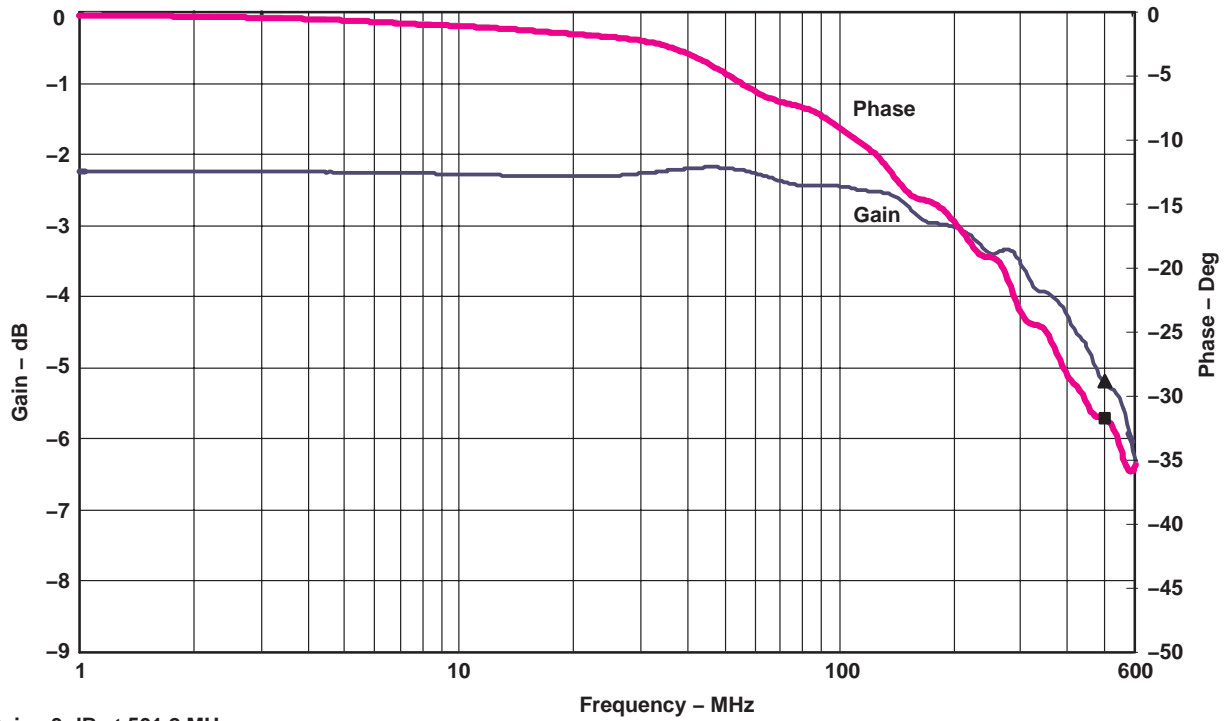

Figure 2.  $r_{on}$  and  $V_O$  vs  $V_I$  ( $V_{CC} = 6.2$  V and  $T_A = 25^\circ\text{C}$ )

# TS5L100 QUAD SPDT WIDE-BANDWIDTH LAN SWITCH WITH LOW ON-STATE RESISTANCE

SCDS163A – MAY 2004 – REVISED MAY 2004

## OPERATING CHARACTERISTICS



- ▲ Gain -3 dB at 501.2 MHz
- Phase at -3-dB Frequency, -31.7 Degrees

Figure 3. Gain/Phase vs Frequency

**OPERATING CHARACTERISTICS**

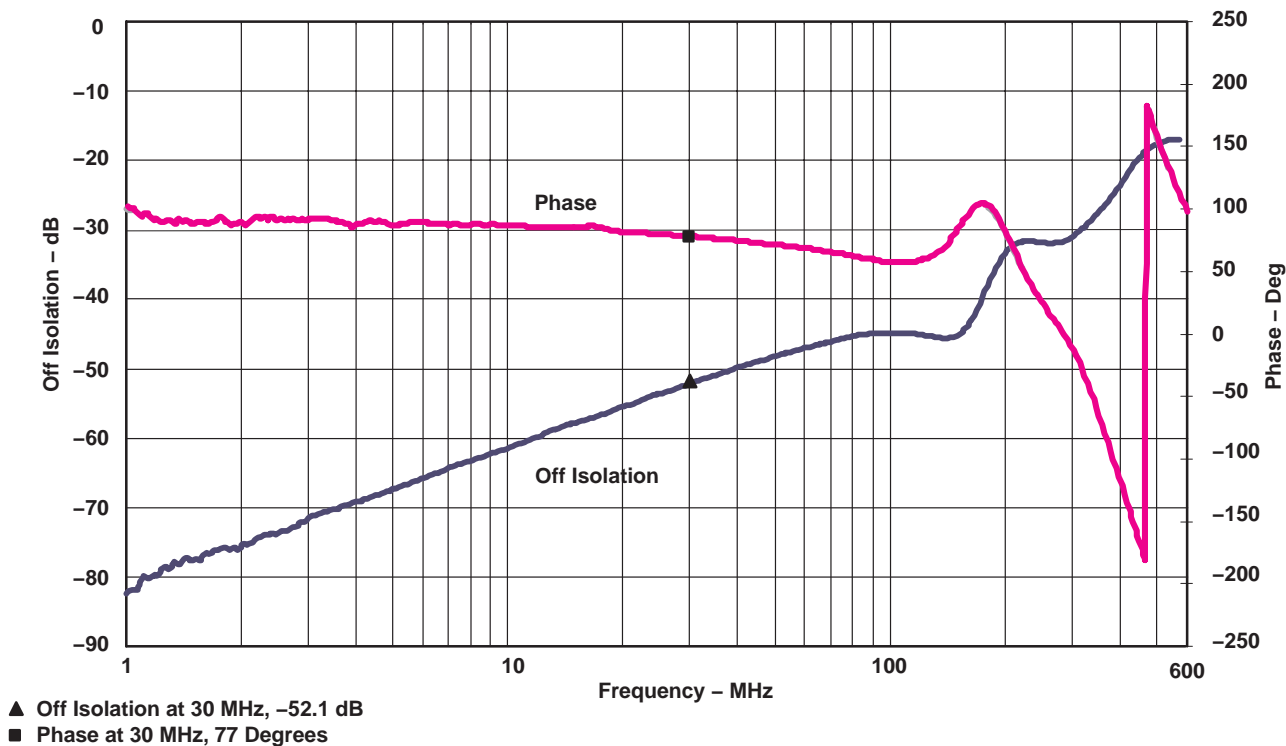

Figure 4. Off Isolation vs Frequency

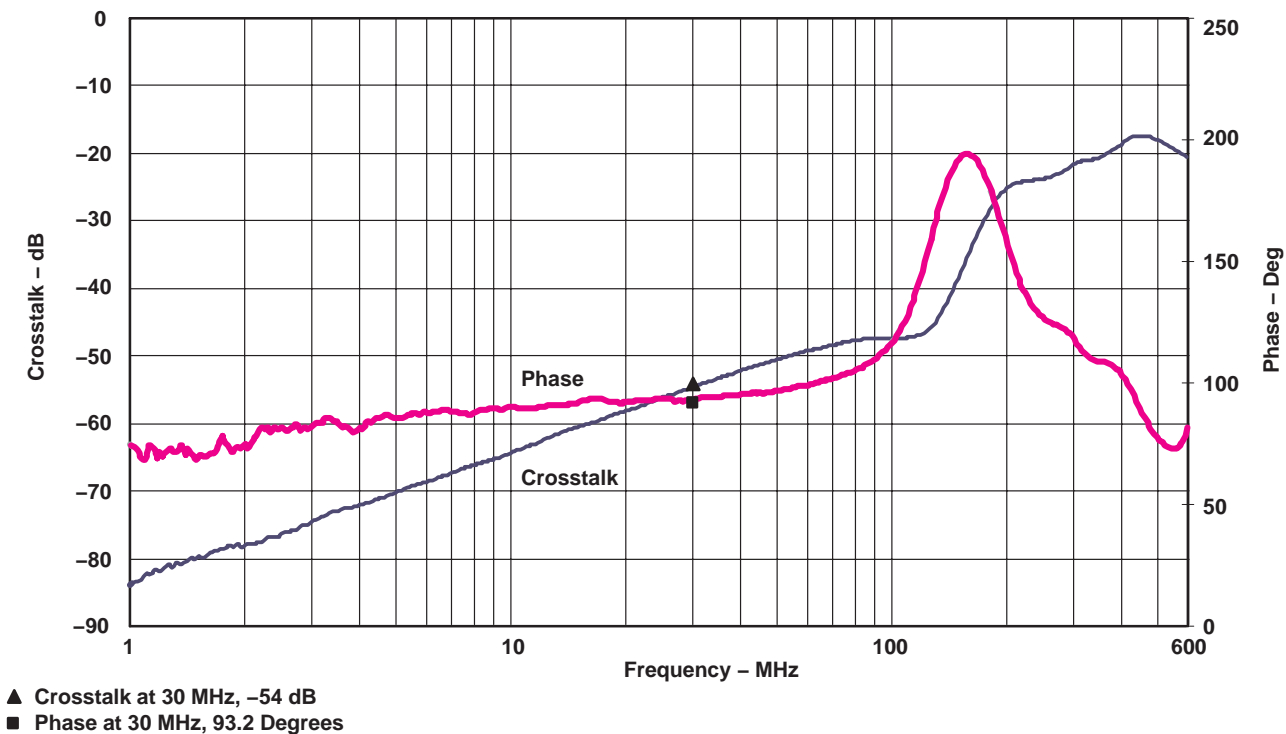

Figure 5. Crosstalk vs Frequency

# TS5L100 QUAD SPDT WIDE-BANDWIDTH LAN SWITCH WITH LOW ON-STATE RESISTANCE

SCDS163A – MAY 2004 – REVISED MAY 2004

## OPERATING CHARACTERISTICS

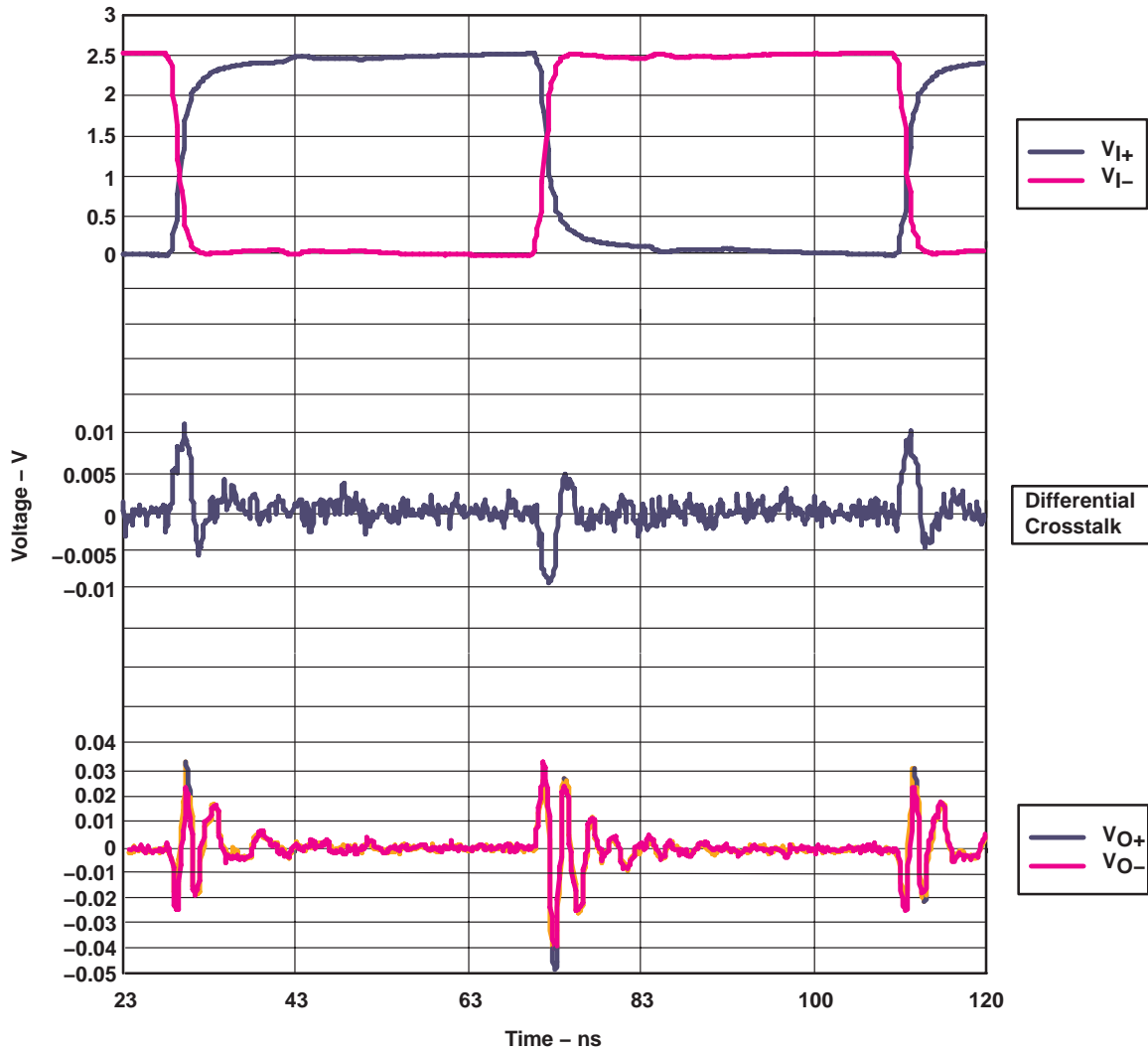
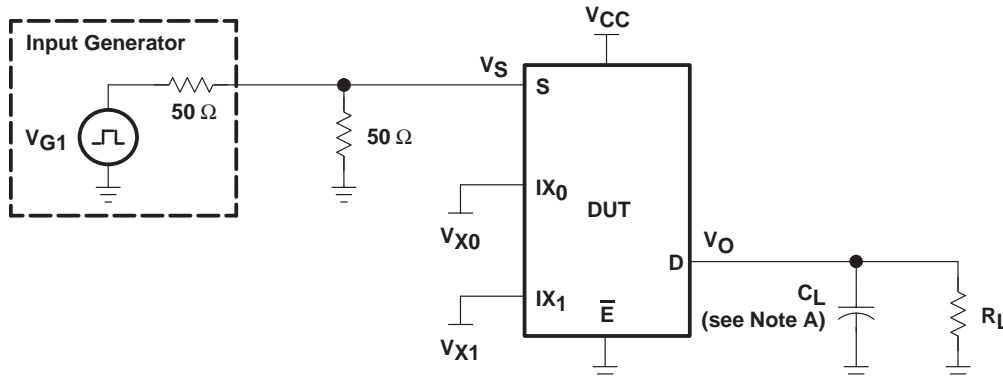

Figure 6. Differential Crosstalk

**TS5L100**  
**QUAD SPDT WIDE-BANDWIDTH LAN SWITCH**  
**WITH LOW ON-STATE RESISTANCE**

SCDS163A – MAY 2004 – REVISED MAY 2004

**PARAMETER MEASUREMENT INFORMATION**



TEST	V <sub>CC</sub>	R <sub>L</sub>	C <sub>L</sub>	V <sub>X0</sub>	V <sub>X1</sub>
t <sub>ON</sub>	6.2 V	100 Ω	35 pF	GND	4.5 V
	6.2 V	100 Ω	35 pF	4.5 V	GND
t <sub>OFF</sub>	6.2 V	100 Ω	35 pF	GND	4.5 V
	6.2 V	100 Ω	35 pF	4.5 V	GND

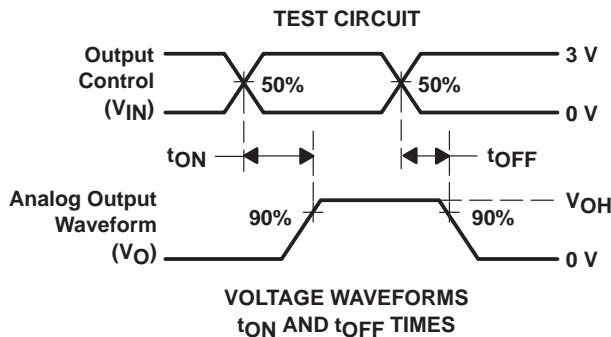

- NOTES: A. C<sub>L</sub> includes probe and jig capacitance.  
 B. All input pulses are supplied by generators having the following characteristics: PRR ≤ 10 MHz, Z<sub>O</sub> = 50 Ω, t<sub>r</sub> ≤ 2.5 ns, t<sub>f</sub> ≤ 2.5 ns.  
 C. The outputs are measured one at a time, with one transition per measurement.

**Figure 7. Test Circuit and Voltage Waveforms**

# TS5L100 QUAD SPDT WIDE-BANDWIDTH LAN SWITCH WITH LOW ON-STATE RESISTANCE

SCDS163A – MAY 2004 – REVISED MAY 2004

## PARAMETER MEASUREMENT INFORMATION

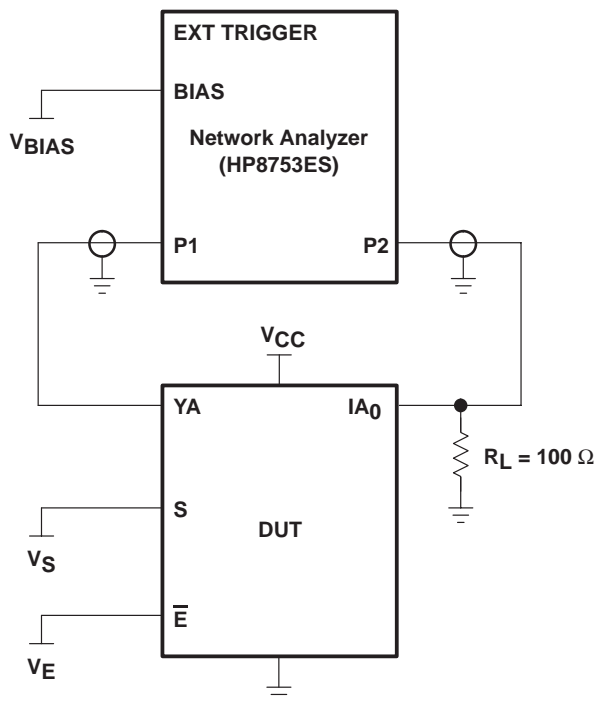

Figure 8. Test Circuit for Frequency Response (BW)

Frequency response is measured at the output of the ON channel. For example, when  $V_S = 0$ ,  $V_E = 0$ , and YA is the input, the output is measured at IA<sub>0</sub>. All unused analog I/O ports are left open.

### HP8753ES setup

Average = 4  
RBW = 3 kHz  
 $V_{BIAS} = 0.35$  V  
ST = 2 s  
P1 = 0 dBm

**PARAMETER MEASUREMENT INFORMATION**

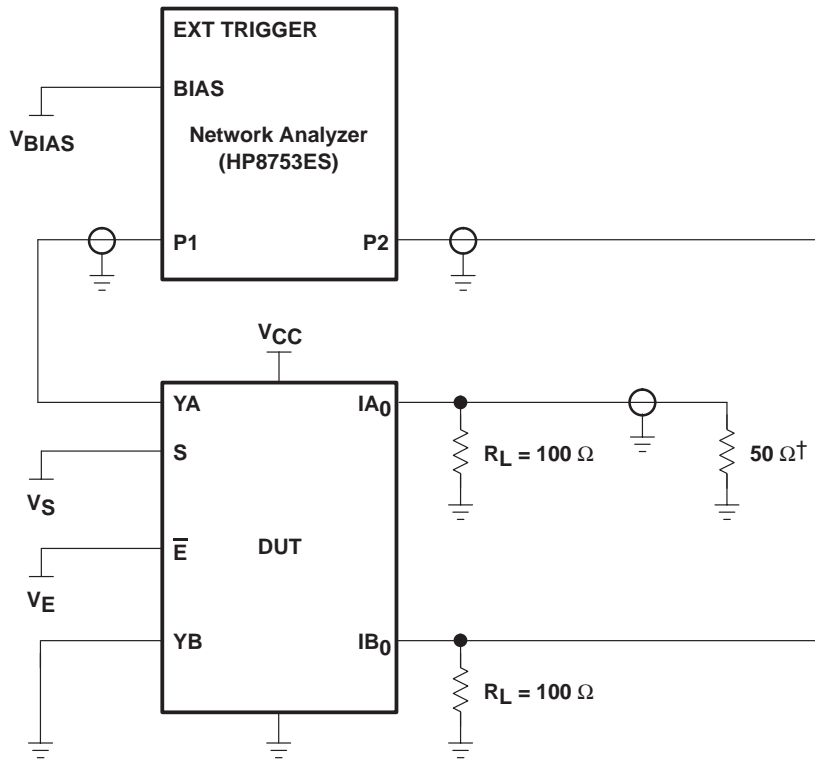

† A 50-Ω termination resistor is needed for the network analyzer.

**Figure 9. Test Circuit for Crosstalk ( $X_{TALK}$ )**

Crosstalk is measured at the output of the nonadjacent ON channel. For example, when  $V_S = 0$ ,  $V_E = 0$ , and YA is the input, the output is measured at  $IB_0$ . All unused analog input (Y) ports are connected to GND, and output (A) ports are connected to GND through 50-Ω pulldown resistors.

**HP8753ES setup**

- Average = 4
- RBW = 3 kHz
- $V_{BIAS} = 0.35\text{ V}$
- ST = 2 s
- P1 = 0 dBm

# TS5L100 QUAD SPDT WIDE-BANDWIDTH LAN SWITCH WITH LOW ON-STATE RESISTANCE

SCDS163A – MAY 2004 – REVISED MAY 2004

## PARAMETER MEASUREMENT INFORMATION

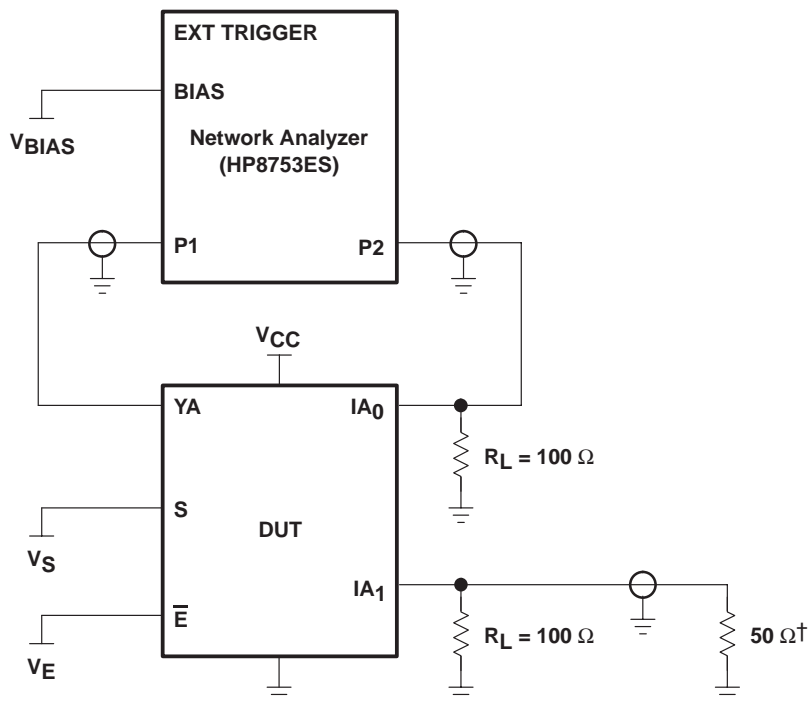

† A 50- $\Omega$  termination resistor is needed for the network analyzer.

**Figure 10. Test Circuit for Off Isolation ( $O_{IRR}$ )**

Off isolation is measured at the output of the OFF channel. For example, when  $V_S = V_{CC}$ ,  $V_E = 0$ , and YA is the input, the output is measured at IA<sub>0</sub>. All unused analog input (Y) ports are left open, and output (A) ports are connected to GND through 50- $\Omega$  pulldown resistors.

### HP8753ES setup

Average = 4  
 RBW = 3 kHz  
 $V_{BIAS} = 0.35$  V  
 ST = 2 s  
 P1 = 0 dBm

**PARAMETER MEASUREMENT INFORMATION**

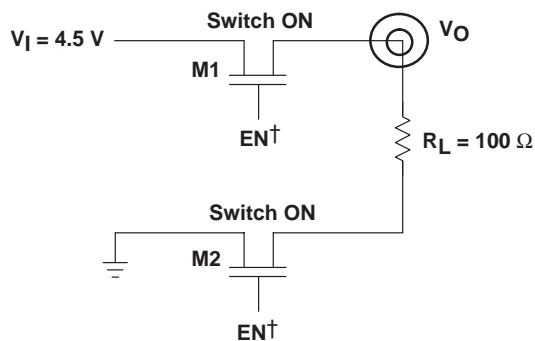

† EN is the internal enable signal applied to the switch.

NOTE A:  $r_{on}$  (M1) and  $r_{on}$  (M2) are calculated from the voltage drop and current across the two terminals of M1 and M2, respectively.

**Figure 11. Test Circuit for  $V_O$  and  $r_{on}$**

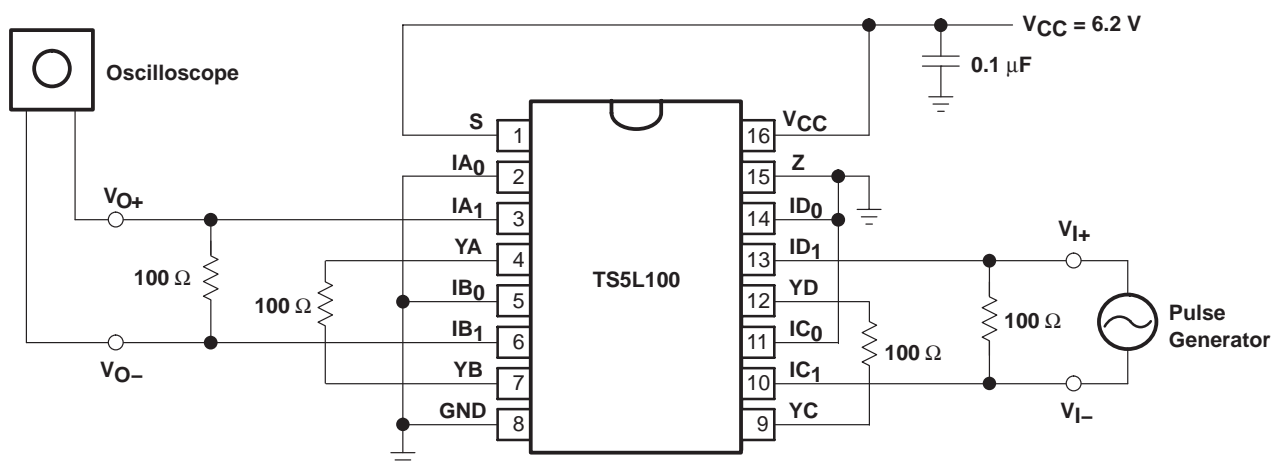

**Figure 12. Differential Crosstalk Measurement**

Differential crosstalk is a measure of coupling noise between a transmit and receive pair in the LAN application. Differential crosstalk depends on the edge rate, frequency, and load. This is calculated from the equation,  $X_{TALK}(Diff)$  db =  $20 \log V_O(Diff)/V_I(Diff)$ , where  $V_O(Diff)$  is the differential output voltage and  $V_I(Diff)$  is the differential input voltage.

**PACKAGING INFORMATION**

Orderable Device	Status (1)	Package Type	Package Drawing	Pins	Package Qty	Eco Plan (2)	Lead/Ball Finish (6)	MSL Peak Temp (3)	Op Temp (°C)	Device Marking (4/5)	Samples
TS5L100D	ACTIVE	SOIC	D	16	40	Green (RoHS & no Sb/Br)	CU NIPDAU	Level-1-260C-UNLIM	0 to 70	TS5L100	<a href="#">Samples</a>
TS5L100DBQR	ACTIVE	SSOP	DBQ	16	2500	Green (RoHS & no Sb/Br)	CU NIPDAU	Level-2-260C-1 YEAR	0 to 70	TG100	<a href="#">Samples</a>
TS5L100DBQRG4	ACTIVE	SSOP	DBQ	16	2500	Green (RoHS & no Sb/Br)	CU NIPDAU	Level-2-260C-1 YEAR	0 to 70	TG100	<a href="#">Samples</a>
TS5L100DG4	ACTIVE	SOIC	D	16	40	Green (RoHS & no Sb/Br)	CU NIPDAU	Level-1-260C-UNLIM	0 to 70	TS5L100	<a href="#">Samples</a>
TS5L100DR	ACTIVE	SOIC	D	16	2500	Green (RoHS & no Sb/Br)	CU NIPDAU	Level-1-260C-UNLIM	0 to 70	TS5L100	<a href="#">Samples</a>
TS5L100PW	ACTIVE	TSSOP	PW	20	70	Green (RoHS & no Sb/Br)	CU NIPDAU	Level-1-260C-UNLIM	0 to 70	TG100	<a href="#">Samples</a>
TS5L100PWG4	ACTIVE	TSSOP	PW	20	70	Green (RoHS & no Sb/Br)	CU NIPDAU	Level-1-260C-UNLIM	0 to 70	TG100	<a href="#">Samples</a>
TS5L100PWR	ACTIVE	TSSOP	PW	20	2000	Green (RoHS & no Sb/Br)	CU NIPDAU	Level-1-260C-UNLIM	0 to 70	TG100	<a href="#">Samples</a>

(1) The marketing status values are defined as follows:

**ACTIVE:** Product device recommended for new designs.

**LIFEBUY:** TI has announced that the device will be discontinued, and a lifetime-buy period is in effect.

**NRND:** Not recommended for new designs. Device is in production to support existing customers, but TI does not recommend using this part in a new design.

**PREVIEW:** Device has been announced but is not in production. Samples may or may not be available.

**OBSOLETE:** TI has discontinued the production of the device.

(2) Eco Plan - The planned eco-friendly classification: Pb-Free (RoHS), Pb-Free (RoHS Exempt), or Green (RoHS & no Sb/Br) - please check <http://www.ti.com/productcontent> for the latest availability information and additional product content details.

**TBD:** The Pb-Free/Green conversion plan has not been defined.

**Pb-Free (RoHS):** TI's terms "Lead-Free" or "Pb-Free" mean semiconductor products that are compatible with the current RoHS requirements for all 6 substances, including the requirement that lead not exceed 0.1% by weight in homogeneous materials. Where designed to be soldered at high temperatures, TI Pb-Free products are suitable for use in specified lead-free processes.

**Pb-Free (RoHS Exempt):** This component has a RoHS exemption for either 1) lead-based flip-chip solder bumps used between the die and package, or 2) lead-based die adhesive used between the die and leadframe. The component is otherwise considered Pb-Free (RoHS compatible) as defined above.

**Green (RoHS & no Sb/Br):** TI defines "Green" to mean Pb-Free (RoHS compatible), and free of Bromine (Br) and Antimony (Sb) based flame retardants (Br or Sb do not exceed 0.1% by weight in homogeneous material)

(3) MSL, Peak Temp. - The Moisture Sensitivity Level rating according to the JEDEC industry standard classifications, and peak solder temperature.

(4) There may be additional marking, which relates to the logo, the lot trace code information, or the environmental category on the device.

(5) Multiple Device Markings will be inside parentheses. Only one Device Marking contained in parentheses and separated by a "~" will appear on a device. If a line is indented then it is a continuation of the previous line and the two combined represent the entire Device Marking for that device.

(6) Lead/Ball Finish - Orderable Devices may have multiple material finish options. Finish options are separated by a vertical ruled line. Lead/Ball Finish values may wrap to two lines if the finish value exceeds the maximum column width.

**Important Information and Disclaimer:**The information provided on this page represents TI's knowledge and belief as of the date that it is provided. TI bases its knowledge and belief on information provided by third parties, and makes no representation or warranty as to the accuracy of such information. Efforts are underway to better integrate information from third parties. TI has taken and continues to take reasonable steps to provide representative and accurate information but may not have conducted destructive testing or chemical analysis on incoming materials and chemicals. TI and TI suppliers consider certain information to be proprietary, and thus CAS numbers and other limited information may not be available for release.

In no event shall TI's liability arising out of such information exceed the total purchase price of the TI part(s) at issue in this document sold by TI to Customer on an annual basis.

**TAPE AND REEL INFORMATION**
**REEL DIMENSIONS**

**TAPE DIMENSIONS**

A0	Dimension designed to accommodate the component width
B0	Dimension designed to accommodate the component length
K0	Dimension designed to accommodate the component thickness
W	Overall width of the carrier tape
P1	Pitch between successive cavity centers

**TAPE AND REEL INFORMATION**

\*All dimensions are nominal

Device	Package Type	Package Drawing	Pins	SPQ	Reel Diameter (mm)	Reel Width W1 (mm)	A0 (mm)	B0 (mm)	K0 (mm)	P1 (mm)	W (mm)	Pin1 Quadrant
TS5L100DR	SOIC	D	16	2500	330.0	16.4	6.5	10.3	2.1	8.0	16.0	Q1
TS5L100PWR	TSSOP	PW	20	2000	330.0	16.4	6.95	7.1	1.6	8.0	16.0	Q1

**TAPE AND REEL BOX DIMENSIONS**

\*All dimensions are nominal

Device	Package Type	Package Drawing	Pins	SPQ	Length (mm)	Width (mm)	Height (mm)
TS5L100DR	SOIC	D	16	2500	333.2	345.9	28.6
TS5L100PWR	TSSOP	PW	20	2000	367.0	367.0	38.0

D (R-PDSO-G16)

PLASTIC SMALL OUTLINE



4040047-6/M 06/11

- NOTES:
- A. All linear dimensions are in inches (millimeters).
  - B. This drawing is subject to change without notice.
  -  C. Body length does not include mold flash, protrusions, or gate burrs. Mold flash, protrusions, or gate burrs shall not exceed 0.006 (0,15) each side.
  -  D. Body width does not include interlead flash. Interlead flash shall not exceed 0.017 (0,43) each side.
  - E. Reference JEDEC MS-012 variation AC.

D (R-PDSO-G16)

PLASTIC SMALL OUTLINE



- NOTES:
- A. All linear dimensions are in millimeters.
  - B. This drawing is subject to change without notice.
  - C. Publication IPC-7351 is recommended for alternate designs.
  - D. Laser cutting apertures with trapezoidal walls and also rounding corners will offer better paste release. Customers should contact their board assembly site for stencil design recommendations. Refer to IPC-7525 for other stencil recommendations.
  - E. Customers should contact their board fabrication site for solder mask tolerances between and around signal pads.



PW (R-PDSO-G20)

PLASTIC SMALL OUTLINE



- NOTES:
- A. All linear dimensions are in millimeters.
  - B. This drawing is subject to change without notice.
  - C. Publication IPC-7351 is recommended for alternate design.
  - D. Laser cutting apertures with trapezoidal walls and also rounding corners will offer better paste release. Customers should contact their board assembly site for stencil design recommendations. Refer to IPC-7525 for other stencil recommendations.
  - E. Customers should contact their board fabrication site for solder mask tolerances between and around signal pads.

DBQ (R-PDSO-G16)

PLASTIC SMALL-OUTLINE PACKAGE

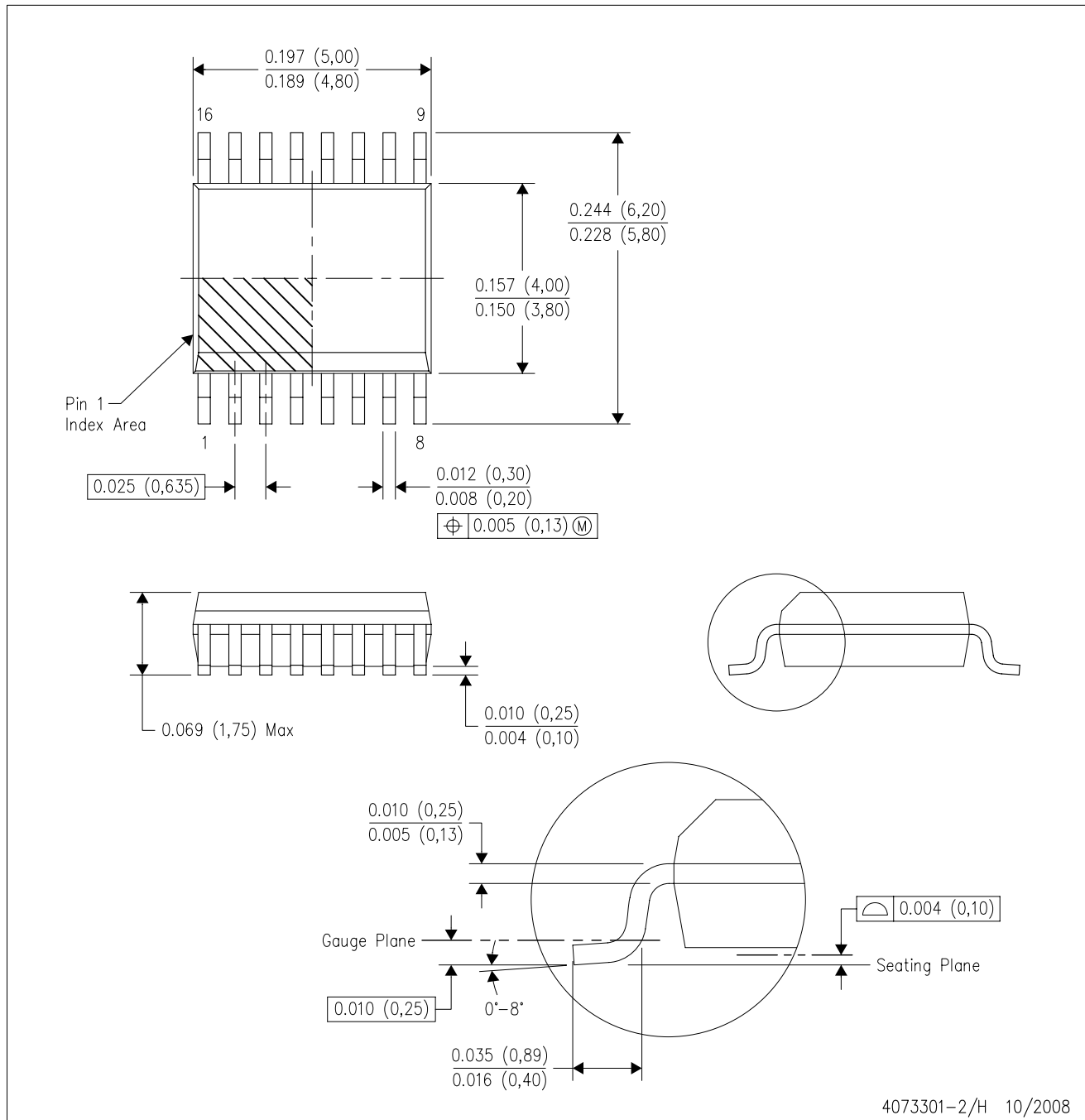

- NOTES:
- A. All linear dimensions are in inches (millimeters).
  - B. This drawing is subject to change without notice.
  - C. Body dimensions do not include mold flash or protrusion not to exceed 0.006 (0,15) per side.
  - D. Falls within JEDEC MO-137 variation AB.

DBQ (R-PDSO-G16)

PLASTIC SMALL OUTLINE PACKAGE

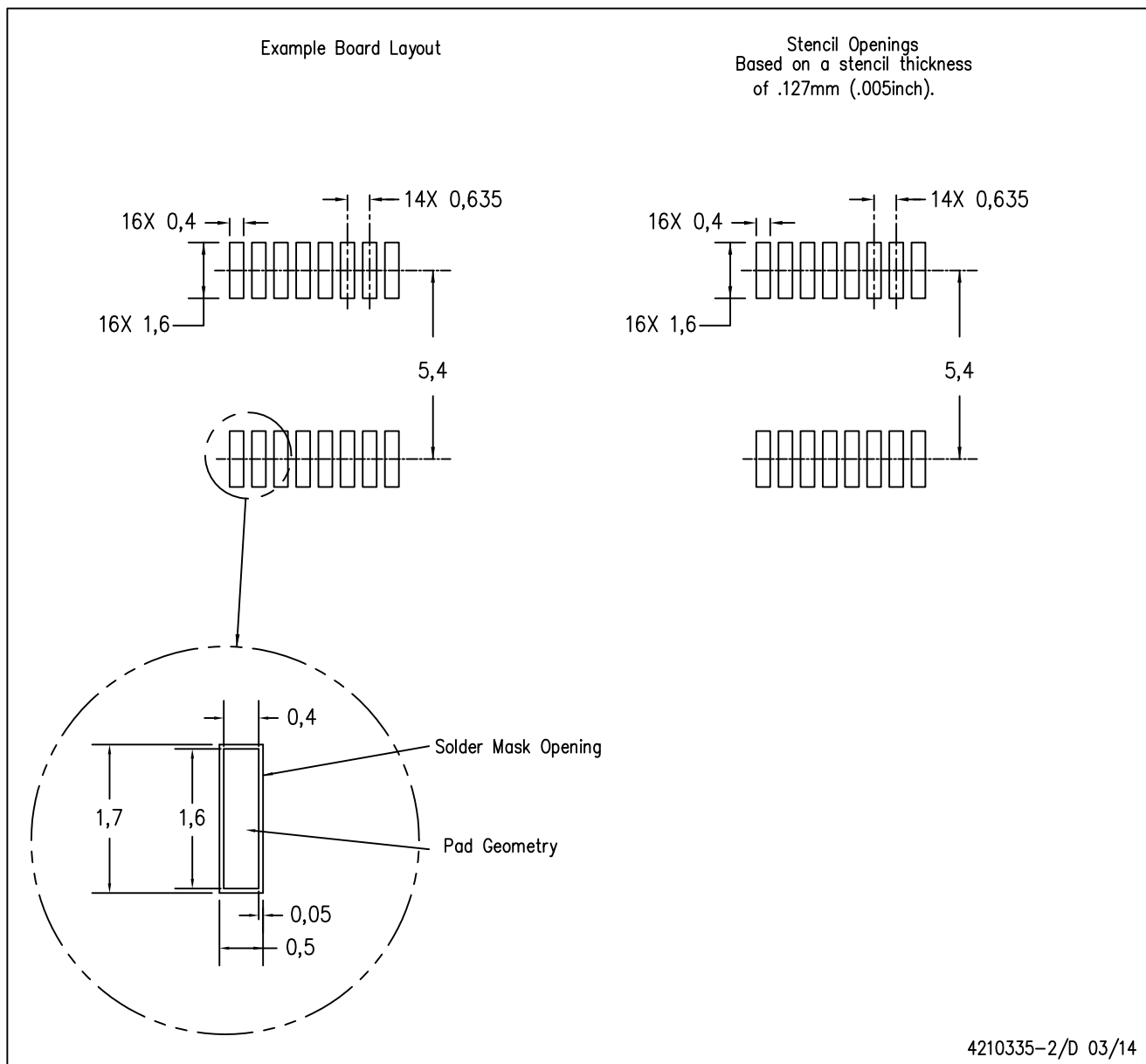

- NOTES:
- A. All linear dimensions are in millimeters.
  - B. This drawing is subject to change without notice.
  - C. Publication IPC-7351 is recommended for alternate designs.
  - D. Laser cutting apertures with trapezoidal walls and also rounding corners will offer better paste release. Customers should contact their board assembly site for stencil design recommendations. Example stencil design based on a 50% volumetric metal load solder paste. Refer to IPC-7525 for other stencil recommendations.

## IMPORTANT NOTICE

Texas Instruments Incorporated and its subsidiaries (TI) reserve the right to make corrections, enhancements, improvements and other changes to its semiconductor products and services per JESD46, latest issue, and to discontinue any product or service per JESD48, latest issue. Buyers should obtain the latest relevant information before placing orders and should verify that such information is current and complete. All semiconductor products (also referred to herein as "components") are sold subject to TI's terms and conditions of sale supplied at the time of order acknowledgment.

TI warrants performance of its components to the specifications applicable at the time of sale, in accordance with the warranty in TI's terms and conditions of sale of semiconductor products. Testing and other quality control techniques are used to the extent TI deems necessary to support this warranty. Except where mandated by applicable law, testing of all parameters of each component is not necessarily performed.

TI assumes no liability for applications assistance or the design of Buyers' products. Buyers are responsible for their products and applications using TI components. To minimize the risks associated with Buyers' products and applications, Buyers should provide adequate design and operating safeguards.

TI does not warrant or represent that any license, either express or implied, is granted under any patent right, copyright, mask work right, or other intellectual property right relating to any combination, machine, or process in which TI components or services are used. Information published by TI regarding third-party products or services does not constitute a license to use such products or services or a warranty or endorsement thereof. Use of such information may require a license from a third party under the patents or other intellectual property of the third party, or a license from TI under the patents or other intellectual property of TI.

Reproduction of significant portions of TI information in TI data books or data sheets is permissible only if reproduction is without alteration and is accompanied by all associated warranties, conditions, limitations, and notices. TI is not responsible or liable for such altered documentation. Information of third parties may be subject to additional restrictions.

Resale of TI components or services with statements different from or beyond the parameters stated by TI for that component or service voids all express and any implied warranties for the associated TI component or service and is an unfair and deceptive business practice. TI is not responsible or liable for any such statements.

Buyer acknowledges and agrees that it is solely responsible for compliance with all legal, regulatory and safety-related requirements concerning its products, and any use of TI components in its applications, notwithstanding any applications-related information or support that may be provided by TI. Buyer represents and agrees that it has all the necessary expertise to create and implement safeguards which anticipate dangerous consequences of failures, monitor failures and their consequences, lessen the likelihood of failures that might cause harm and take appropriate remedial actions. Buyer will fully indemnify TI and its representatives against any damages arising out of the use of any TI components in safety-critical applications.

In some cases, TI components may be promoted specifically to facilitate safety-related applications. With such components, TI's goal is to help enable customers to design and create their own end-product solutions that meet applicable functional safety standards and requirements. Nonetheless, such components are subject to these terms.

No TI components are authorized for use in FDA Class III (or similar life-critical medical equipment) unless authorized officers of the parties have executed a special agreement specifically governing such use.

Only those TI components which TI has specifically designated as military grade or "enhanced plastic" are designed and intended for use in military/aerospace applications or environments. Buyer acknowledges and agrees that any military or aerospace use of TI components which have **not** been so designated is solely at the Buyer's risk, and that Buyer is solely responsible for compliance with all legal and regulatory requirements in connection with such use.

TI has specifically designated certain components as meeting ISO/TS16949 requirements, mainly for automotive use. In any case of use of non-designated products, TI will not be responsible for any failure to meet ISO/TS16949.

### Products

Audio	<a href="http://www.ti.com/audio">www.ti.com/audio</a>
Amplifiers	<a href="http://amplifier.ti.com">amplifier.ti.com</a>
Data Converters	<a href="http://dataconverter.ti.com">dataconverter.ti.com</a>
DLP® Products	<a href="http://www.dlp.com">www.dlp.com</a>
DSP	<a href="http://dsp.ti.com">dsp.ti.com</a>
Clocks and Timers	<a href="http://www.ti.com/clocks">www.ti.com/clocks</a>
Interface	<a href="http://interface.ti.com">interface.ti.com</a>
Logic	<a href="http://logic.ti.com">logic.ti.com</a>
Power Mgmt	<a href="http://power.ti.com">power.ti.com</a>
Microcontrollers	<a href="http://microcontroller.ti.com">microcontroller.ti.com</a>
RFID	<a href="http://www.ti-rfid.com">www.ti-rfid.com</a>
OMAP Applications Processors	<a href="http://www.ti.com/omap">www.ti.com/omap</a>
Wireless Connectivity	<a href="http://www.ti.com/wirelessconnectivity">www.ti.com/wirelessconnectivity</a>

### Applications

Automotive and Transportation	<a href="http://www.ti.com/automotive">www.ti.com/automotive</a>
Communications and Telecom	<a href="http://www.ti.com/communications">www.ti.com/communications</a>
Computers and Peripherals	<a href="http://www.ti.com/computers">www.ti.com/computers</a>
Consumer Electronics	<a href="http://www.ti.com/consumer-apps">www.ti.com/consumer-apps</a>
Energy and Lighting	<a href="http://www.ti.com/energy">www.ti.com/energy</a>
Industrial	<a href="http://www.ti.com/industrial">www.ti.com/industrial</a>
Medical	<a href="http://www.ti.com/medical">www.ti.com/medical</a>
Security	<a href="http://www.ti.com/security">www.ti.com/security</a>
Space, Avionics and Defense	<a href="http://www.ti.com/space-avionics-defense">www.ti.com/space-avionics-defense</a>
Video and Imaging	<a href="http://www.ti.com/video">www.ti.com/video</a>

### TI E2E Community

[e2e.ti.com](http://e2e.ti.com)