

COMPARATOR WITH OUTPUT VOLTAGE-LEVEL TRANSLATION

FEATURES

- **Low Supply Current: 8 μ A (Max)**
- **Supply Voltage: 2.5 V to 5.5 V**
- **Output FET Provides Down Translation**
- **Small Package: SOT-563**
- **Latch-Up Performance Exceeds 100 mA Per JESD 78, Class II**
- **ESD Performance**
 - 2500-V Human-Body Model (JESD-A114E)
 - 250-V Machine Model (EIA/JESD A115-A)
 - 1500-V Charged-Device Model (JESD22-C101-A Level III)

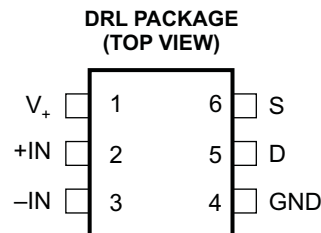

DESCRIPTION/ORDERING INFORMATION

The TXS03121 is a comparator designed for battery monitoring applications. It can be operated with a voltage of 2.5 V to 5.5 V. The reference voltage is applied to the –IN terminal, whereas the voltage to be monitored is connected to +IN. When the voltage at +IN is greater than the voltage at –IN, the output FET is turned On. When the voltage at +IN is less than the voltage at –IN, the output FET is turned Off. The source (S) of the output FET can be connected to 1.1 V to 3.6 V, which allows the output signal to be level translated to another voltage value. The voltage at V₊ must be greater than or equal to the voltage at S. The voltage at S must be greater than or equal to the voltage at D ($V_+ \geq V_S \geq V_D$).

ORDERING INFORMATION

T _A	PACKAGE ⁽¹⁾⁽²⁾		ORDERABLE PART NUMBER	TOP-SIDE MARKING
–40°C to 85°C	SOT-563 – DRL	Tape and reel	TXS03121DRLR	2FR

- (1) For the most current package and ordering information, see the Package Option Addendum at the end of this document, or see the TI web site at www.ti.com.
- (2) Package drawings, thermal data, and symbolization are available at www.ti.com/packaging.



Please be aware that an important notice concerning availability, standard warranty, and use in critical applications of Texas Instruments semiconductor products and disclaimers thereto appears at the end of this data sheet.

APPLICATION BLOCK DIAGRAM

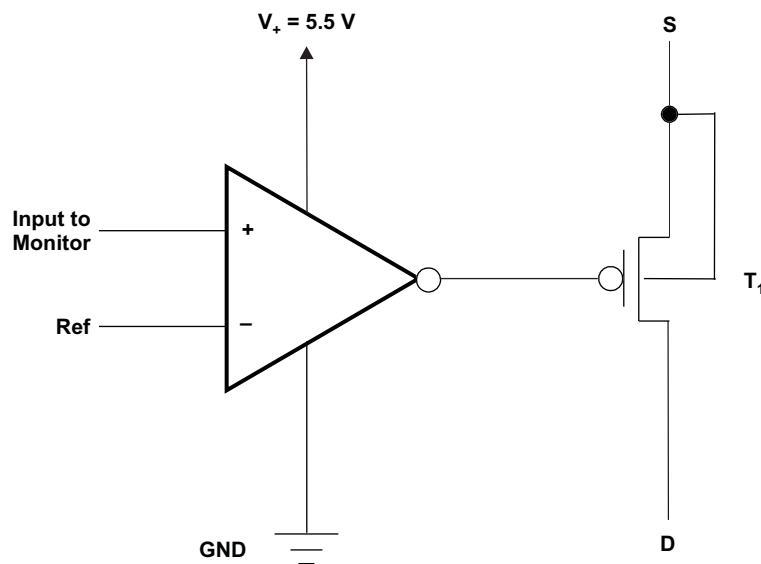

PIN ASSIGNMENTS

NO.	NAME	DESCRIPTION
1	V_+	Comparator supply voltage
2	+IN	Comparator positive input
3	-IN	Comparator negative input
4	GND	Ground
5	D	Drain of output FET
6	S	Source of output FET

ABSOLUTE MAXIMUM RATINGS⁽¹⁾

over operating free-air temperature range (unless otherwise noted)

			MIN	MAX	UNIT
V_+	Supply voltage range ⁽²⁾		–0.5	6.5	V
+IN, –IN	Input voltage range		–0.5	6.5	V
I_{IK}	Input clamp current	$V_I < 0$		–50	mA
I_{OK}	Output clamp current	$V_O < 0$		–50	mA
I_O	Continuous output current (On-state switch current)			–50	mA
	Continuous current through V_+ or GND			±100	mA
θ_{JA}	Package thermal impedance ⁽³⁾	DRL package		171.6	°C/W
T_{stg}	Storage temperature range			150	°C

- (1) Stresses beyond those listed under "absolute maximum ratings" may cause permanent damage to the device. These are stress ratings only, and functional operation of the device at these or any other conditions beyond those indicated under "recommended operating conditions" is not implied. Exposure to absolute-maximum-rated conditions for extended periods may affect device reliability.
- (2) The input and output voltage ratings may be exceeded if the input and output clamp-current ratings are observed.
- (3) The package thermal impedance is calculated in accordance with JESD 51-7.

RECOMMENDED OPERATING CONDITIONS

over operating free-air temperature range (unless otherwise noted)

		MIN	MAX	UNIT
V_+	Comparator supply voltage	2.5	5.5	V
$V_S, V_D^{(1)}$	Output FET source or drain voltage	1.1	3.6	V
T_A	Operating free-air temperature	–40	85	°C

- (1) V_+ must be greater than or equal to V_S , and V_S must be greater than or equal to V_D ($V_+ \geq V_S \geq V_D$).

COMPARATOR ELECTRICAL CHARACTERISTICS

over operating free-air temperature range (unless otherwise noted)

PARAMETER		TEST CONDITIONS		MIN	TYP	MAX	UNIT
V _{OS}	Input offset voltage	V ₊ = 2.5 V to 5.5 V	V _{CM} = 0.8 V, I _O = 0	–10	0.5	10	mV
			V _{CM} = V ₊ , I _O = 0				
V _{CM}	Common-mode voltage range	V ₊ = 2.5 V to 5.5 V		0.8		V ₊	V
I _{+IN}	Input leakage current	V ₊ = 2.5 V to 5.5 V	V _{+IN} = 0 V to V ₊			0.5	μA
I _{–IN}			V _{–IN} = 0 V to V ₊				
I ₊	Supply current	V ₊ = 2.5 V to 5.5 V				8	μA
C _{IN}	Capacitance of +IN, –IN pins				2	2.5	pF

OUTPUT FET ELECTRICAL CHARACTERISTICS

over operating free-air temperature range (unless otherwise noted)

PARAMETER		TEST CONDITIONS		MIN	TYP	MAX	UNIT	
$I_{DS(ON)}$	On leakage current	$V_S = 1.1\text{ V to }3.6\text{ V}$, Switch ON				0.5	μA	
$I_{DS(OFF)}$	Off leakage current	$V_S = 1.1\text{ V to }3.6\text{ V}$, $V_D = \text{Open}$, Switch OFF				0.5	μA	
$C_{(ON)}$	On capacitance			4	5.1	6	pF	
$C_{(OFF)}$	Off capacitance, S and D terminals			1.5	3.4	5	pF	
r_{ON}	On resistance of output FET	$V_+ \geq V_S$, $I_D = -100\ \mu\text{A}$		$V_S = 1.1\text{ V}$		150	Ω	
				$V_S = 1.4\text{ V}$		65		
				$V_S = 1.65\text{ V}$		61		
				$V_S = 2.3\text{ V}$		50		
				$V_S = 3\text{ V}$		44		
t_{EN}	Enable time	20-mV overdrive	$V_{-IN} = 0.8\text{ V}$, $V_S = 1.65\text{ V}$	$V_+ = 4.5\text{ V}$		1.7	μs	
				$V_+ = 3\text{ V}$		3.9		
			$V_{-IN} = V_+$, $V_S = 1.65\text{ V}$	$V_+ = 4.5\text{ V}$		1		
				$V_+ = 3\text{ V}$		3.9		
			50-mV overdrive	$V_{-IN} = 0.8\text{ V}$, $V_S = 1.65\text{ V}$	$V_+ = 4.5\text{ V}$			1.2
					$V_+ = 3\text{ V}$			2.7
		$V_{-IN} = V_+$, $V_S = 1.65\text{ V}$		$V_+ = 2.5\text{ V}$		6.2		
				$V_+ = 4.5\text{ V}$		1		
		$V_+ = 3\text{ V}$			2.4			
					5.3			
		100-mV overdrive	$V_{-IN} = 0.8\text{ V}$, $V_S = 1.65\text{ V}$	$V_+ = 4.5\text{ V}$		0.8		
				$V_+ = 3\text{ V}$		1.4		
$V_{-IN} = V_+$, $V_S = 1.65\text{ V}$	$V_+ = 2.5\text{ V}$			5				
	$V_+ = 4.5\text{ V}$			0.7				
$V_+ = 3\text{ V}$			1.3					
			4.7					
t_{DIS}	Disable time	20-mV overdrive	$V_{-IN} = 0.8\text{ V}$, $V_S = 1.65\text{ V}$	$V_+ = 4.5\text{ V}$		4.4	μs	
				$V_+ = 3\text{ V}$		12		
			$V_{-IN} = V_+$, $V_S = 1.65\text{ V}$	$V_+ = 4.5\text{ V}$		3.5		
				$V_+ = 3\text{ V}$		6.1		
			50-mV overdrive	$V_{-IN} = 0.8\text{ V}$, $V_S = 1.65\text{ V}$	$V_+ = 4.5\text{ V}$			4.1
					$V_+ = 3\text{ V}$			9.6
		$V_{-IN} = V_+$, $V_S = 1.65\text{ V}$		$V_+ = 2.5\text{ V}$		5.3		
				$V_+ = 4.5\text{ V}$		2.5		
		$V_+ = 3\text{ V}$			3.2			
					5.2			
		100-mV overdrive	$V_{-IN} = 0.8\text{ V}$, $V_S = 1.65\text{ V}$	$V_+ = 4.5\text{ V}$		4.6		
				$V_+ = 3\text{ V}$		6.7		
			$V_{-IN} = V_+$, $V_S = 1.65\text{ V}$	$V_+ = 2.5\text{ V}$		5.2		
				$V_+ = 4.5\text{ V}$		1.9		
			$V_+ = 3\text{ V}$		2.8			
					4.9			

PARAMETER MEASUREMENT INFORMATION

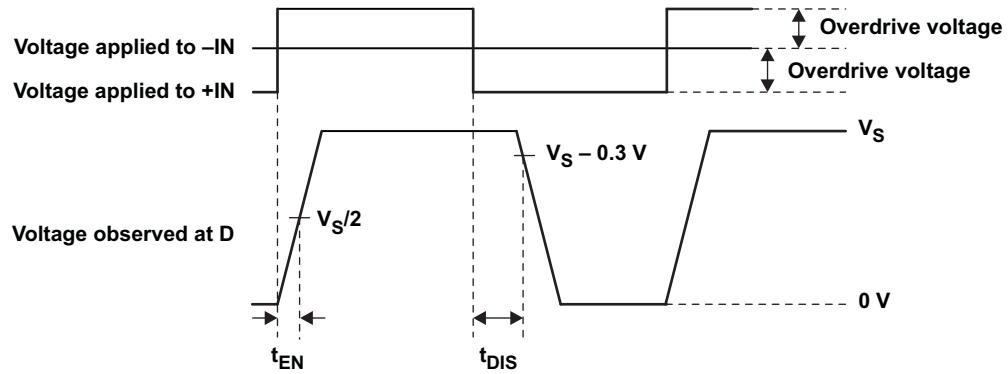
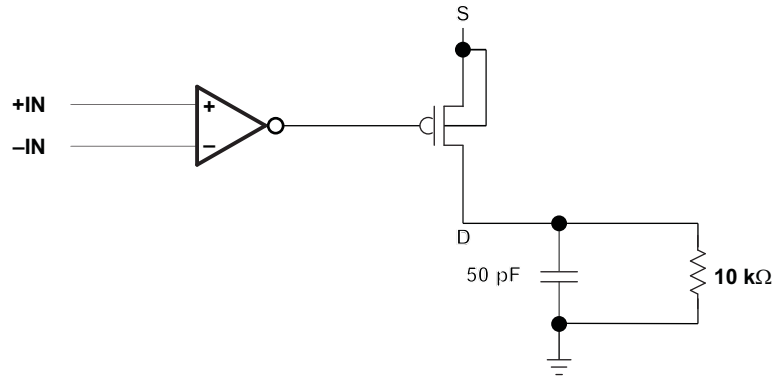

PACKAGING INFORMATION

Orderable Device	Status (1)	Package Type	Package Drawing	Pins	Package Qty	Eco Plan (2)	Lead/Ball Finish (6)	MSL Peak Temp (3)	Op Temp (°C)	Device Marking (4/5)	Samples
TXS03121DRLR	ACTIVE	SOT	DRL	6	4000	Green (RoHS & no Sb/Br)	CU NIPDAU	Level-1-260C-UNLIM	-40 to 85	2FR	Samples

(1) The marketing status values are defined as follows:

ACTIVE: Product device recommended for new designs.

LIFEBUY: TI has announced that the device will be discontinued, and a lifetime-buy period is in effect.

NRND: Not recommended for new designs. Device is in production to support existing customers, but TI does not recommend using this part in a new design.

PREVIEW: Device has been announced but is not in production. Samples may or may not be available.

OBSOLETE: TI has discontinued the production of the device.

(2) Eco Plan - The planned eco-friendly classification: Pb-Free (RoHS), Pb-Free (RoHS Exempt), or Green (RoHS & no Sb/Br) - please check <http://www.ti.com/productcontent> for the latest availability information and additional product content details.

TBD: The Pb-Free/Green conversion plan has not been defined.

Pb-Free (RoHS): TI's terms "Lead-Free" or "Pb-Free" mean semiconductor products that are compatible with the current RoHS requirements for all 6 substances, including the requirement that lead not exceed 0.1% by weight in homogeneous materials. Where designed to be soldered at high temperatures, TI Pb-Free products are suitable for use in specified lead-free processes.

Pb-Free (RoHS Exempt): This component has a RoHS exemption for either 1) lead-based flip-chip solder bumps used between the die and package, or 2) lead-based die adhesive used between the die and leadframe. The component is otherwise considered Pb-Free (RoHS compatible) as defined above.

Green (RoHS & no Sb/Br): TI defines "Green" to mean Pb-Free (RoHS compatible), and free of Bromine (Br) and Antimony (Sb) based flame retardants (Br or Sb do not exceed 0.1% by weight in homogeneous material)

(3) MSL, Peak Temp. - The Moisture Sensitivity Level rating according to the JEDEC industry standard classifications, and peak solder temperature.

(4) There may be additional marking, which relates to the logo, the lot trace code information, or the environmental category on the device.

(5) Multiple Device Markings will be inside parentheses. Only one Device Marking contained in parentheses and separated by a "~" will appear on a device. If a line is indented then it is a continuation of the previous line and the two combined represent the entire Device Marking for that device.

(6) Lead/Ball Finish - Orderable Devices may have multiple material finish options. Finish options are separated by a vertical ruled line. Lead/Ball Finish values may wrap to two lines if the finish value exceeds the maximum column width.

Important Information and Disclaimer: The information provided on this page represents TI's knowledge and belief as of the date that it is provided. TI bases its knowledge and belief on information provided by third parties, and makes no representation or warranty as to the accuracy of such information. Efforts are underway to better integrate information from third parties. TI has taken and continues to take reasonable steps to provide representative and accurate information but may not have conducted destructive testing or chemical analysis on incoming materials and chemicals. TI and TI suppliers consider certain information to be proprietary, and thus CAS numbers and other limited information may not be available for release.

In no event shall TI's liability arising out of such information exceed the total purchase price of the TI part(s) at issue in this document sold by TI to Customer on an annual basis.

TAPE AND REEL INFORMATION

REEL DIMENSIONS

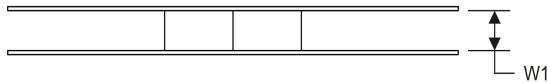
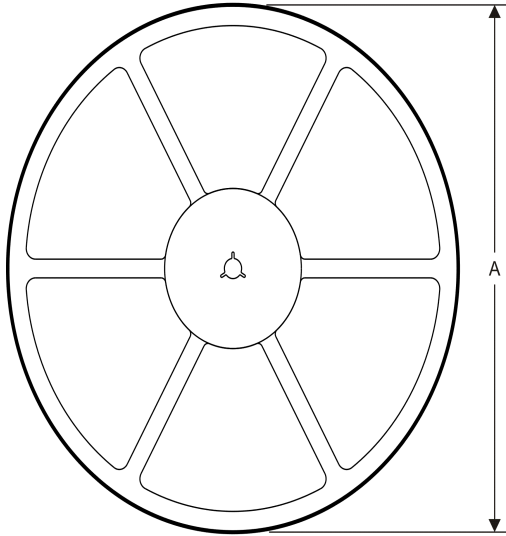

TAPE DIMENSIONS

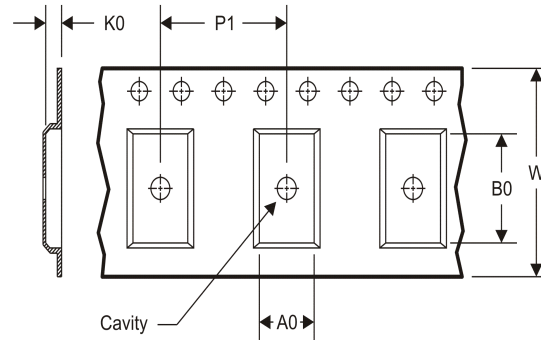

A0	Dimension designed to accommodate the component width
B0	Dimension designed to accommodate the component length
K0	Dimension designed to accommodate the component thickness
W	Overall width of the carrier tape
P1	Pitch between successive cavity centers

TAPE AND REEL INFORMATION

*All dimensions are nominal

Device	Package Type	Package Drawing	Pins	SPQ	Reel Diameter (mm)	Reel Width W1 (mm)	A0 (mm)	B0 (mm)	K0 (mm)	P1 (mm)	W (mm)	Pin1 Quadrant
TXS03121DRLR	SOT	DRL	6	4000	180.0	8.4	1.98	1.78	0.69	4.0	8.0	Q3

TAPE AND REEL BOX DIMENSIONS



*All dimensions are nominal

Device	Package Type	Package Drawing	Pins	SPQ	Length (mm)	Width (mm)	Height (mm)
TXS03121DRLR	SOT	DRL	6	4000	202.0	201.0	28.0

DRL (R-PDSO-N6)

PLASTIC SMALL OUTLINE

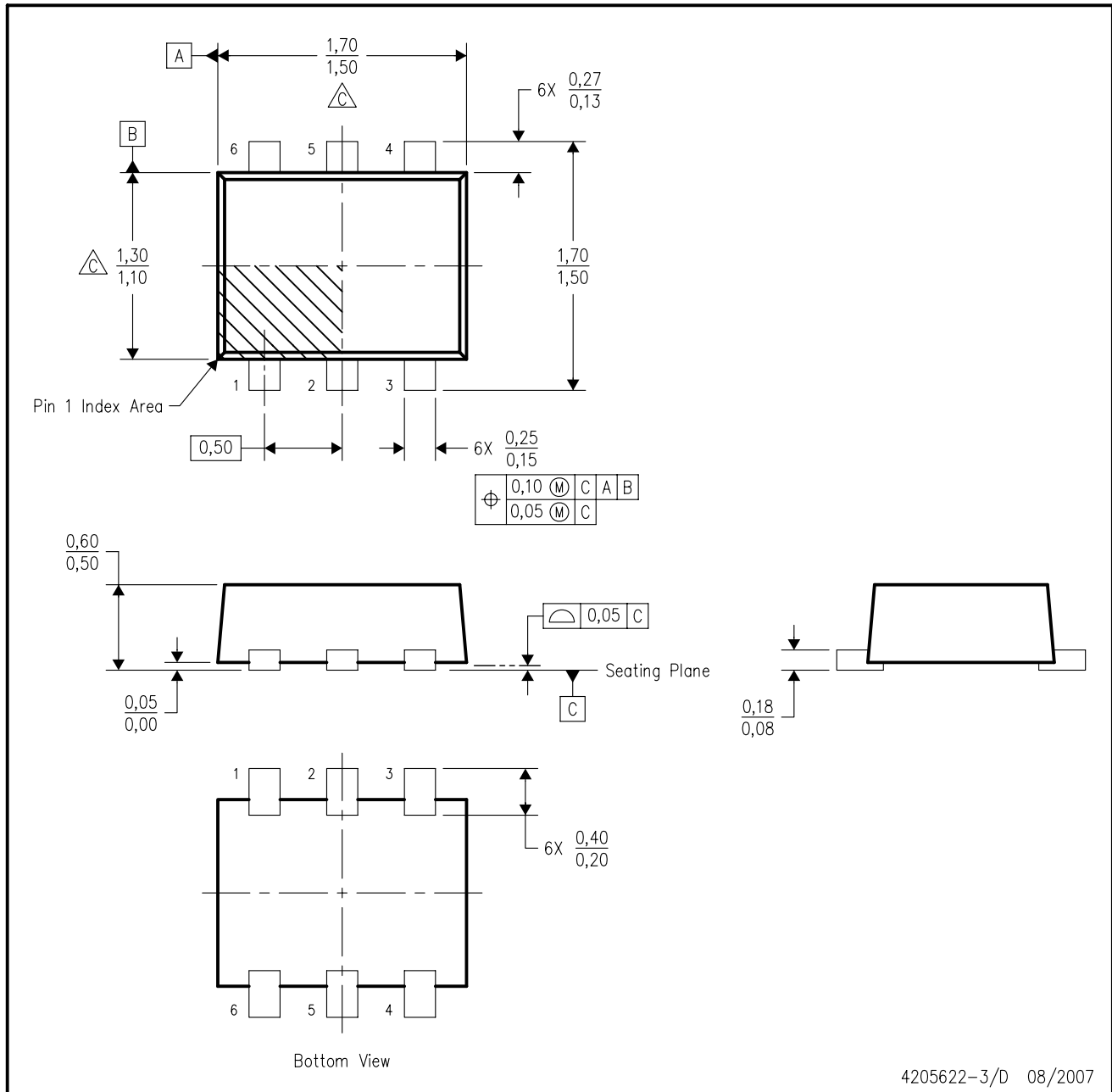

4205622-3/D 08/2007

- NOTES:
- A. All linear dimensions are in millimeters. Dimensioning and tolerancing per ASME Y14.5M-1994.
 - B. This drawing is subject to change without notice.
 - C. Body dimensions do not include mold flash, interlead flash, protrusions, or gate burrs. Mold flash, interlead flash, protrusions, or gate burrs shall not exceed 0,15 per end or side.
 - D. JEDEC package registration is pending.

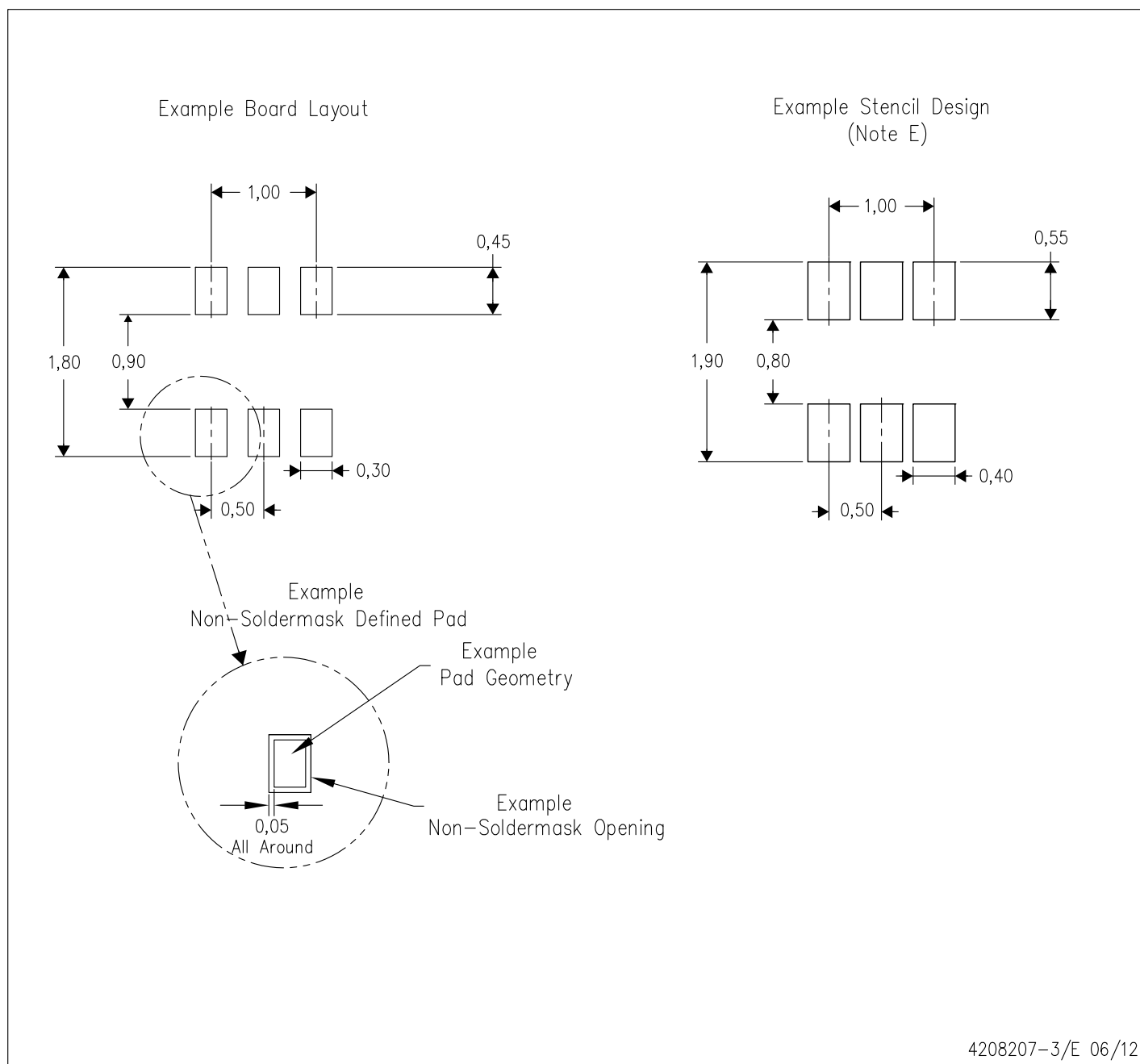

- NOTES:
- All linear dimensions are in millimeters.
 - This drawing is subject to change without notice.
 - Publication IPC-7351 is recommended for alternate designs.
 - Customers should contact their board fabrication site for minimum solder mask web tolerances between signal pads.
 - Maximum stencil thickness 0,127 mm (5 mils). All linear dimensions are in millimeters.
 - Laser cutting apertures with trapezoidal walls and also rounding corners will offer better paste release. Customers should contact their board assembly site for stencil design recommendations. Refer to IPC 7525 for stencil design considerations.
 - Side aperture dimensions over-print land for acceptable area ratio > 0.66. Customer may reduce side aperture dimensions if stencil manufacturing process allows for sufficient release at smaller opening.

IMPORTANT NOTICE

Texas Instruments Incorporated and its subsidiaries (TI) reserve the right to make corrections, enhancements, improvements and other changes to its semiconductor products and services per JESD46, latest issue, and to discontinue any product or service per JESD48, latest issue. Buyers should obtain the latest relevant information before placing orders and should verify that such information is current and complete. All semiconductor products (also referred to herein as "components") are sold subject to TI's terms and conditions of sale supplied at the time of order acknowledgment.

TI warrants performance of its components to the specifications applicable at the time of sale, in accordance with the warranty in TI's terms and conditions of sale of semiconductor products. Testing and other quality control techniques are used to the extent TI deems necessary to support this warranty. Except where mandated by applicable law, testing of all parameters of each component is not necessarily performed.

TI assumes no liability for applications assistance or the design of Buyers' products. Buyers are responsible for their products and applications using TI components. To minimize the risks associated with Buyers' products and applications, Buyers should provide adequate design and operating safeguards.

TI does not warrant or represent that any license, either express or implied, is granted under any patent right, copyright, mask work right, or other intellectual property right relating to any combination, machine, or process in which TI components or services are used. Information published by TI regarding third-party products or services does not constitute a license to use such products or services or a warranty or endorsement thereof. Use of such information may require a license from a third party under the patents or other intellectual property of the third party, or a license from TI under the patents or other intellectual property of TI.

Reproduction of significant portions of TI information in TI data books or data sheets is permissible only if reproduction is without alteration and is accompanied by all associated warranties, conditions, limitations, and notices. TI is not responsible or liable for such altered documentation. Information of third parties may be subject to additional restrictions.

Resale of TI components or services with statements different from or beyond the parameters stated by TI for that component or service voids all express and any implied warranties for the associated TI component or service and is an unfair and deceptive business practice. TI is not responsible or liable for any such statements.

Buyer acknowledges and agrees that it is solely responsible for compliance with all legal, regulatory and safety-related requirements concerning its products, and any use of TI components in its applications, notwithstanding any applications-related information or support that may be provided by TI. Buyer represents and agrees that it has all the necessary expertise to create and implement safeguards which anticipate dangerous consequences of failures, monitor failures and their consequences, lessen the likelihood of failures that might cause harm and take appropriate remedial actions. Buyer will fully indemnify TI and its representatives against any damages arising out of the use of any TI components in safety-critical applications.

In some cases, TI components may be promoted specifically to facilitate safety-related applications. With such components, TI's goal is to help enable customers to design and create their own end-product solutions that meet applicable functional safety standards and requirements. Nonetheless, such components are subject to these terms.

No TI components are authorized for use in FDA Class III (or similar life-critical medical equipment) unless authorized officers of the parties have executed a special agreement specifically governing such use.

Only those TI components which TI has specifically designated as military grade or "enhanced plastic" are designed and intended for use in military/aerospace applications or environments. Buyer acknowledges and agrees that any military or aerospace use of TI components which have **not** been so designated is solely at the Buyer's risk, and that Buyer is solely responsible for compliance with all legal and regulatory requirements in connection with such use.

TI has specifically designated certain components as meeting ISO/TS16949 requirements, mainly for automotive use. In any case of use of non-designated products, TI will not be responsible for any failure to meet ISO/TS16949.

Products

Audio	www.ti.com/audio
Amplifiers	amplifier.ti.com
Data Converters	dataconverter.ti.com
DLP® Products	www.dlp.com
DSP	dsp.ti.com
Clocks and Timers	www.ti.com/clocks
Interface	interface.ti.com
Logic	logic.ti.com
Power Mgmt	power.ti.com
Microcontrollers	microcontroller.ti.com
RFID	www.ti-rfid.com
OMAP Applications Processors	www.ti.com/omap
Wireless Connectivity	www.ti.com/wirelessconnectivity

Applications

Automotive and Transportation	www.ti.com/automotive
Communications and Telecom	www.ti.com/communications
Computers and Peripherals	www.ti.com/computers
Consumer Electronics	www.ti.com/consumer-apps
Energy and Lighting	www.ti.com/energy
Industrial	www.ti.com/industrial
Medical	www.ti.com/medical
Security	www.ti.com/security
Space, Avionics and Defense	www.ti.com/space-avionics-defense
Video and Imaging	www.ti.com/video

TI E2E Community

e2e.ti.com