

## 5-V to 35-V HOT SWAP POWER MANAGER

### FEATURES

- 5-V to 35-V Operation
- Precision Maximum Current Control
- Precision Fault Threshold
- Programmable Average Power Limiting
- Programmable Overcurrent Limit
- Shutdown Control
- Charge Pump for Low  $R_{DS(on)}$  High-Side Drive
- Latch Reset Function Available
- Output Drive  $V_{GS}$  Clamping
- Fault Output Indication
- 18-Pin DIL and SOIC Packages

### DESCRIPTION

The UC3914 family of hot swap power managers provides complete power management, hot swap and fault handling capability. Integrating this part and a few external components, allows a board to be swapped in or out upon failure or system modification without removing power to the hardware, while maintaining the integrity of the powered system. Complementary output drivers and diodes have been integrated for use with external capacitors as a charge pump to ensure sufficient gate drive to the external N-channel MOSFET transistor for low  $R_{DS(on)}$ . All control and housekeeping functions are integrated and externally programmable and include the fault current level, maximum output sourcing current, maximum fault time and average power limiting of the external FET. The UC3914 features a duty ratio current limiting technique, which provides peak load capability while limiting the average power dissipation of the external pass transistor during fault conditions. The fault level is fixed at 50 mV with respect to  $V_{CC}$  to minimize total dropout.

The fault current level is set with an external current sense resistor. The maximum allowable sourcing current is programmed by using a resistor divider from  $V_{CC}$  to REF to set the voltage on IMAX. The maximum current level, when the output appears as a current source is  $(V_{VCC} - V_{IMAX})/R_{SENSE}$ .

This part is offered in both 18-pin DW wide-body (SOIC) and dual-in-line (DIL) packages.

### SIMPLIFIED APPLICATION DIAGRAM

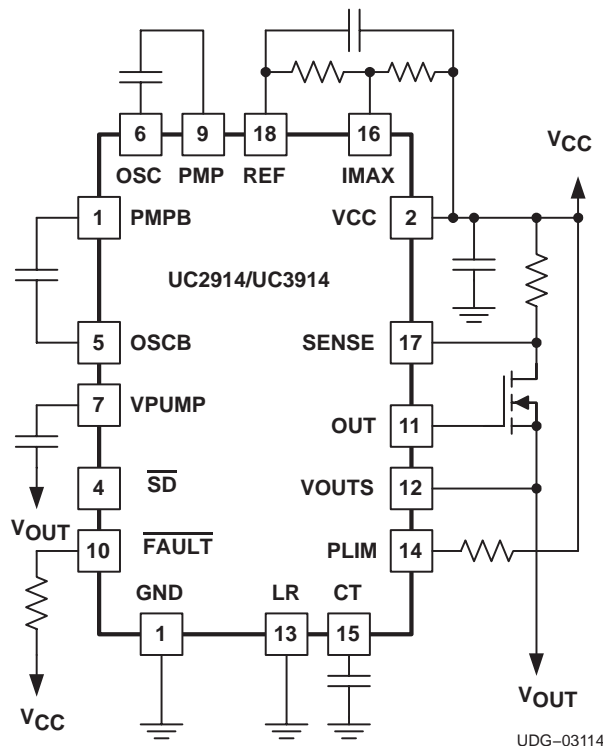

Please be aware that an important notice concerning availability, standard warranty, and use in critical applications of Texas Instruments semiconductor products and disclaimers thereto appears at the end of this data sheet.

**DESCRIPTION (continued)**

When the output current is less than the fault level, the external output transistor remains switched on. When the output current exceeds the fault level, but is less than the maximum sourcing level programmed by IMAX, the output remains switched on, and the fault timer starts to charge C<sub>T</sub>, a timing capacitor. Once C<sub>T</sub> charges to 2.5 V, the output device is turned off and C<sub>T</sub> is slowly discharged. Once C<sub>T</sub> is discharged to 0.5 V, the device performs a retry and the output transistor is switched on again. The UC3914 offers two distinct reset modes. In one mode with LR left floating or held low, the device tries to reset itself repeatedly if a fault occurs as described above. In the second mode with LR held high, once a fault occurs, the output is latched off until either LR is toggled low, the part is shutdown then re-enabled using  $\overline{SD}$ , or the power to the part is turned off and then on again.

**ABSOLUTE MAXIMUM RATINGS**

over operating free-air temperature range unless otherwise noted.<sup>(1)(2)</sup>

		UC2914 UC3914	UNIT
Input supply voltage	VCC	40	V
Maximum forced voltage	$\overline{SD}$ , LR	12	
	IMAX	VCC	
Maximum current	$\overline{FAULT}$	20	mA
	PLIM	10	
Maximum voltage	$\overline{FAULT}$	40	V
Reference output current		internally limited	A
Storage temperature range, T <sub>stg</sub>		-65 to 150	°C
Junction temperature range, T <sub>J</sub>		-55 to 150	
Lead temperature 1,6 mm (1/16 inch) from case for 10 seconds		300	

- (1) Stresses beyond those listed under absolute maximum ratings may cause permanent damage to the device. These are stress ratings only, and functional operation of the device at these or any other conditions beyond those indicated under recommended operating conditions is not implied. Exposure to Absolute Maximum Rated conditions for extended periods may affect device reliability
- (2) Currents are positive into and negative out of the specific terminal unless otherwise noted. All voltage values are with respect to the network ground terminal.

**RECOMMENDED OPERATING CONDITIONS**

		MIN	NOM	MAX	UNIT
Supply voltage, VCC		5		35	V
Operating free-air temperature range, T <sub>A</sub>	UC2914	-40		85	°C
	UC3914	0		70	

PRODUCT PREVIEW

**ELECTRICAL CHARACTERISTICS**

T<sub>A</sub> = 0°C to 70°C for the UC3914, –40°C to 85°C for the UC2914, V<sub>CC</sub> = 12V, V<sub>PUMP</sub> = V<sub>PUMP(max)</sub>,  $\overline{SD}$  = 5 V, C<sub>P1</sub> = C<sub>P2</sub> = C<sub>PUMP</sub> = 0.01 μF. T<sub>A</sub> = T<sub>J</sub>. (Unless otherwise specified)

PARAMETER		TEST CONDITIONS	MIN	TYP	MAX	UNIT
<b>SUPPLY CURRENTS</b>						
I <sub>CC</sub>	Supply current(2)			8	15	mA
		V <sub>CC</sub> = 35 V		12	20	
I <sub>CCSD</sub>	Shutdown supply current	$\overline{SD}$ = 0 V,		500	900	μA
	UVLO turn-on threshold voltage			4.0	4.4	V
	UVLO hysteresis		55	120	250	mV
<b>FAULT TIMING</b>						
	Overcurrent threshold	T <sub>J</sub> = 25°C, wrt V <sub>CC</sub>	–55	–50	–45	mV
		Over operating temperature wrt V <sub>CC</sub>	–57	–50	–42	
	IMAX input bias			1	3	μA
I <sub>CT_CHG</sub>	CT charge current	V <sub>CT</sub> = 1 V	–140	–100	–60	
		V <sub>CT</sub> = 1 V, overload condition	–6.0	–3.0	–1.5	
I <sub>CT_DSCH</sub>	CT discharge current	V <sub>CT</sub> = 1 V	2.0	3.0	4.5	μA
V <sub>CT_FLT</sub>	CT fault threshold voltage		2.25	2.50	2.75	V
V <sub>CT_RST</sub>	CT reset threshold voltage		0.45	0.50	0.55	
	Output duty cycle	Fault condition, I <sub>PL</sub> = 0 A	1.5%	3.0%	4.5%	
<b>OUTPUT</b>						
V <sub>OH</sub>	High-level output voltage	V <sub>VOUTS</sub> = V <sub>CC</sub> , V <sub>PUMP</sub> = V <sub>PUMP(max)</sub> , wrt V <sub>PUMP</sub>	–1.5	–1.0		V
		V <sub>VOUTS</sub> = V <sub>CC</sub> , V <sub>PUMP</sub> = V <sub>PUMP(max)</sub> , I <sub>OUT</sub> = –2 mA, wrt V <sub>PUMP</sub>	–2.0	–1.5		
V <sub>OL</sub>	Low-level output voltage	I <sub>OUT</sub> = 0 A		0.8	1.3	
		I <sub>OUT</sub> = 5 mA		1	2	
		I <sub>OUT</sub> = 25 mA, V <sub>VOUTS</sub> = 0 V, overload condition		1.2	1.8	
V <sub>OUT(cl)</sub>	Output clamp voltage	V <sub>VOUTS</sub> = 0 V	11.5	13.0	14.5	
t <sub>RISE</sub>	Rise time(1)	C <sub>OUT</sub> = 1 nF		750	1250	ns
t <sub>FALL</sub>	Fall time(1)	C <sub>OUT</sub> = 1 nF		250	500	
<b>LINEAR CURRENT AMPLIFIER</b>						
V <sub>IO</sub>	Input offset voltage		–15	0	15	mV
	Voltage gain		60	80		dB
V <sub>IMAX</sub>	IMAX control voltage	V <sub>IMAX</sub> = V <sub>OUT</sub> , V <sub>SENSE</sub> = V <sub>VCC</sub> , wrt V <sub>CC</sub>	–20	0	20	mV
		V <sub>IMAX</sub> = V <sub>OUT</sub> , V <sub>SENSE</sub> = V <sub>REF</sub> , wrt REF	–20	0	20	
	SENSE input bias			1.5	3.5	μA
<b>SHUTDOWN</b>						
	Shutdown threshold voltage		0.6	1.5	2.0	V
	input current	$\overline{SD}$ = 5 V		150	300	μA
	Delay to output time(1)			0.5	2.0	μs

(1) Ensured by design. Not production tested.

(2) A mathematical averaging is used to determine this value. See Application Section for more information.

**ELECTRICAL CHARACTERISTICS**

T<sub>A</sub> = 0°C to 70°C for the UC3914, -40°C to 85°C for the UC2914, V<sub>CC</sub> = 12V, V<sub>PUMP</sub> = V<sub>PUMP(max)</sub>,  $\overline{SD}$  = 5 V, C<sub>P1</sub> = C<sub>P2</sub> = C<sub>PUMP</sub> = 0.01 μF.  
T<sub>A</sub> = T<sub>J</sub>. (Unless otherwise specified)

PARAMETER		TEST CONDITIONS	MIN	TYP	MAX	UNIT
<b>CHARGE PUMP</b>						
f <sub>OSC</sub> , f <sub>OSCB</sub>	Oscillator frequency	OSC, OSCB	60	150	250	kHz
V <sub>OH</sub>	High-level output voltage	I <sub>OSC</sub> = -5 mA	10.0	11.0	11.6	V
V <sub>OL</sub>	Low-level output voltage	I <sub>OSC</sub> = 5 mA		0.2	0.5	
	Output clamp voltage	V <sub>CC</sub> = 25 V	18.5	20.5	22.5	V
I <sub>LIM</sub>	Output current limit	High side only	-20	-10	-3	mA
	Pump diode voltage drop	I <sub>DIODE</sub> = 10 mA, measured from PMP to PMPB, PMPB to VPUMP	0.5	0.9	1.3	V
	PMP clamp voltage	V <sub>CC</sub> = 25 V	18.5	20.5	22.5	
VPUMP maximum voltage		V <sub>VOUS</sub> = V <sub>CC</sub> charge pump disable threshold, V <sub>CC</sub> = 12 V	20	22	24	
		V <sub>VOUS</sub> = V <sub>CC</sub> charge pump disable threshold, V <sub>CC</sub> = 35 V	42	45	48	
VPUMP hysteresis		V <sub>VOUS</sub> = V <sub>CC</sub> charge pump re-enable threshold, V <sub>CC</sub> = 12 V	0.3	0.7	1.4	
		V <sub>VOUS</sub> = V <sub>CC</sub> charge pump re-enable threshold, V <sub>CC</sub> = 35 V	0.25	0.70	1.40	
<b>REFERENCE</b>						
	REF output voltage	wrt V <sub>CC</sub>	-2.25	-2.00	-1.75	V
	REF current limit		12.5	20.0	50.0	mA
	Load regulation	1 mA ≤ I <sub>VREF</sub> ≤ 5 mA		25	60	mV
	Line regulation	5 V ≤ V <sub>VCC</sub> ≤ 35 V		25	100	
<b>FAULT</b>						
	Low-level output voltage	I <sub>FAULT</sub> = 1 mA		100	200	mV
	Output leakage	V <sub>FAULT</sub> = 35 V		10	500	nA
<b>LATCH</b>						
	Latch release threshold voltage	High-to-low	0.6	1.4	2.0	V
	Input current	V <sub>LR</sub> = 5 V		500	750	μA
<b>POWER LIMITING</b>						
Duty cycle control		I <sub>PLIM</sub> = 200 μA In fault mode	0.6%	1.3%	2.0%	
		I <sub>PLIM</sub> = 3 mA In fault mode	0.05%	0.12%	0.20%	
<b>OVERLOAD</b>						
	Delay-to-output time <sup>(1)</sup>			500	1250	ns
	Threshold voltage	wrt IMAX	-250	-200	-150	mV

(1) Ensured by design. Not production tested.

(2) A mathematical averaging is used to determine this value. See Application Section for more information.

AVAILABLE OPTIONS

TA	PACKAGED DEVICES	
	PLASTIC DIL-18 (N)	PLASTIC SOIC (DW)(1)
-40°C to 85°C	UC2914N	UC2914DW
0°C to 70°C	UC3914N	UC3914DW

(1) The DW package is available taped and reeled. Add an TR suffix to the device type (e.g. UC2914DWTR) to order quantities of 2,000 devices per reel.

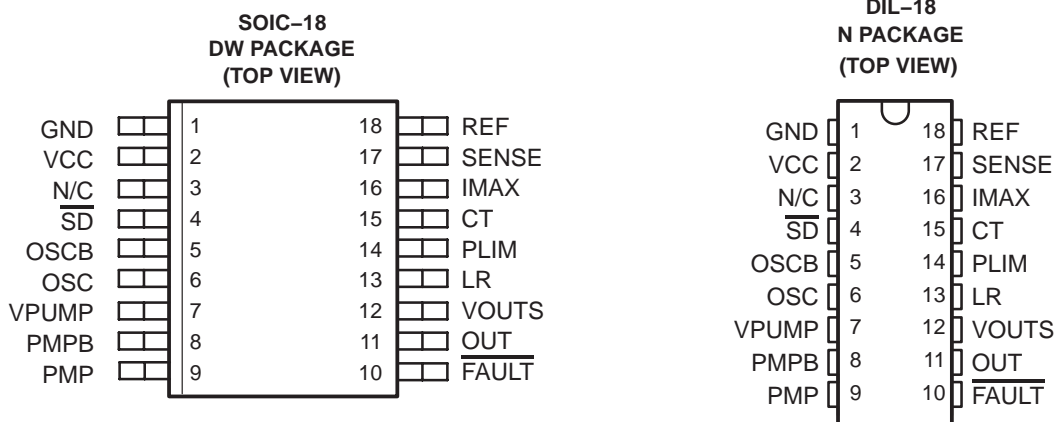

BLOCK DIAGRAM

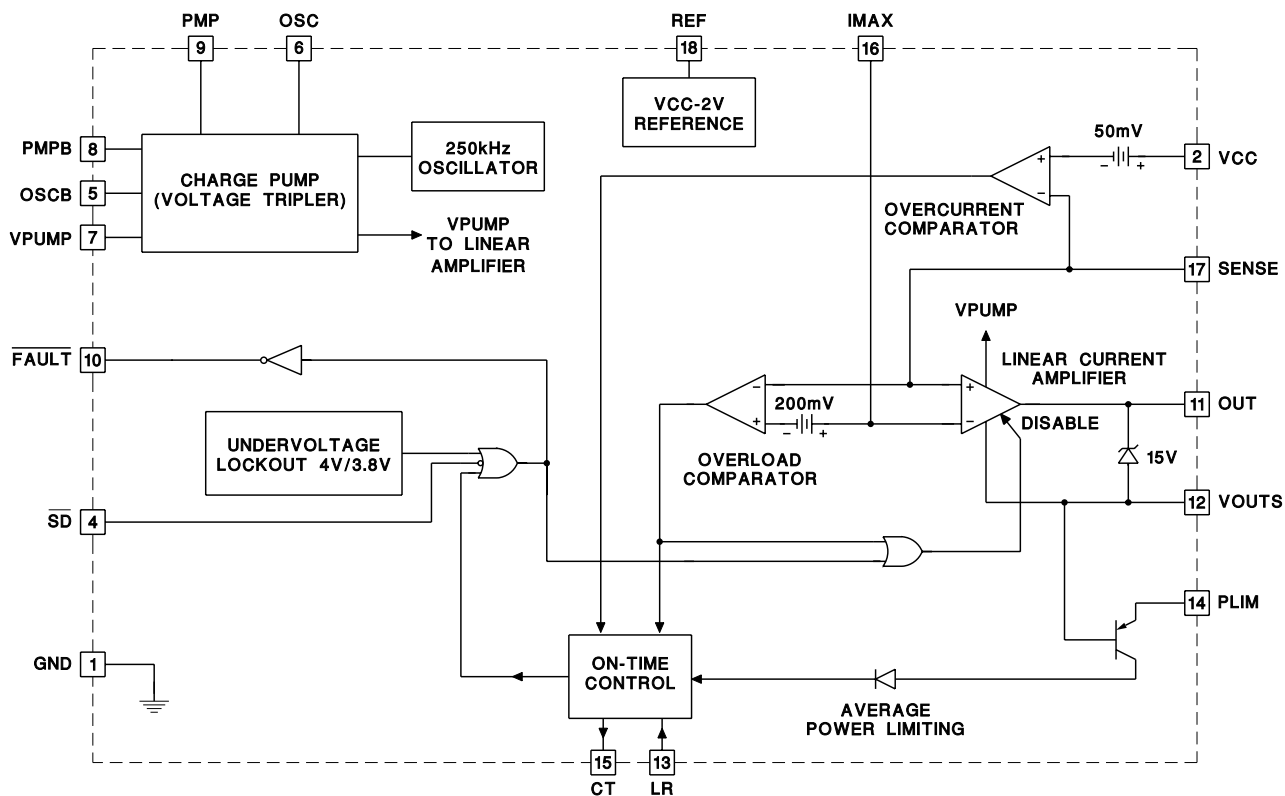

UDG-95134-2

**TERMINAL FUNCTIONS**

TERMINAL		I/O	DESCRIPTION
NAME	NO.		
CT	15	I/O	A capacitor is connected to this pin in order to set the maximum fault time. The minimum fault time must be more than the time to charge external load capacitance. The fault time is defined as shown in equation (1) where $I_{CH} = 100 \mu A + I_{PL}$ , where $I_{PL}$ is the current into the power limit pin. Once the fault time is reached the output shuts down for a time given by equation (2) where $I_{DIS}$ is nominally $3 \mu A$ .
$\overline{\text{FAULT}}$	10	O	Open collector output which pulls low upon any of the following conditions: timer fault, shutdown, UVLO. This pin <b>MUST</b> be pulled up to $V_{VCC}$ or another supply through a suitable impedance.
GND	1	–	Ground reference for the device.
IMAX	16	I	This pin programs the maximum allowable sourcing current. Since REF is a $-2\text{-V}$ reference (with respect to VCC), a voltage divider can be derived from VCC to REF in order to generate the program level for the IMAX pin. The current level at which the output appears as a current source is equal to the voltage on the IMAX pin, with respect to VCC, divided by the current sense resistor. If desired, a controlled current startup can be programmed with a capacitor on IMAX to VCC.
LR	13	I	If this pin is held high and a fault occurs, the timer is prevented from resetting the fault latch when CT is discharged below the reset comparator threshold. The part does not retry until this pin is brought to a logic low or a power-on-reset occurs. Pulling this pin low before the reset time is reached does not clear the fault until the reset time is reached. Floating or holding this pin low results in the part repeatedly trying to reset itself if a fault occurs.
OUT	11	O	Output drive to the MOSFET pass element. Internal clamping ensures that the maximum $V_{GS}$ drive is 15 V.
OSC	6	O	Complementary output drivers for intermediate charge pump stages. A $0.01\text{-}\mu\text{F}$ capacitor should be placed between OSC and PMP, and OSCB and PMPB.
OSCB	5	O	
PLIM	14	I	This feature ensures that the average MOSFET power dissipation is controlled. A resistor is connected from this pin to VCC. Current flows into PLIM, adding to the fault timer charge current, reducing the duty cycle from the typical 3% level. When $I_{PL} \gg 100 \mu A$ then the average MOSFET power dissipation is given by equation (3).
PMP	9	I	Complementary pins which couple charge pump capacitors to internal diodes and are used to provide charge to the reservoir capacitor tied to VPUMP. Typical capacitor values used are $0.01\text{-}\mu\text{F}$ .
PMPB	8	I	
REF	18	O	$-2\text{-V}$ reference with respect to VCC used to program the IMAX pin voltage. A $0.1\text{-}\mu\text{F}$ ceramic or tantalum capacitor <b>MUST</b> be tied between this pin and VCC to ensure proper operation of the device.
$\overline{\text{SD}}$	4	I	When this TTL-compatible input is brought to a logic low, the output of the linear amplifier is driven low, $\overline{\text{FAULT}}$ is pulled low and the device is put into a low power mode. The <b>ABSOLUTE</b> maximum voltage that can be placed on this pin is 12 V.
SENSE	17	I	Input voltage from the current sense resistor. When there is greater than 50 mV on this pin with respect to VCC, a fault is sensed and CT begins to charge.
VCC	2	I	Input voltage to the device. The voltage range is from 4.5 V to 35 V. The minimum input voltage required for operation is 4.5 V.
VOUTS	12	O	Source connection of external N-channel MOSFET and sensed output voltage of load.
VPUMP	7	O	Charge pump output voltage. A capacitor should be tied between this pin and VOUTS with a typical value being $0.01\text{-}\mu\text{F}$ .

$$T_{\text{FAULT}} = \frac{2 \times C_T}{I_{\text{CH}}} \tag{1}$$

$$T_{\text{SD}} = \frac{2 \times C_T}{I_{\text{DIS}}} \tag{2}$$

$$P_{\text{FET(avg)}} = I_{\text{MAX}} \times 3 \times 10^{-6} \times R_{\text{PL}} \tag{3}$$

APPLICATION INFORMATION

The UC3914 is to be used in conjunction with external passive components and an N-channel MOSFET to facilitate hot swap capability of application modules. A typical application setup is given in Figure 1.

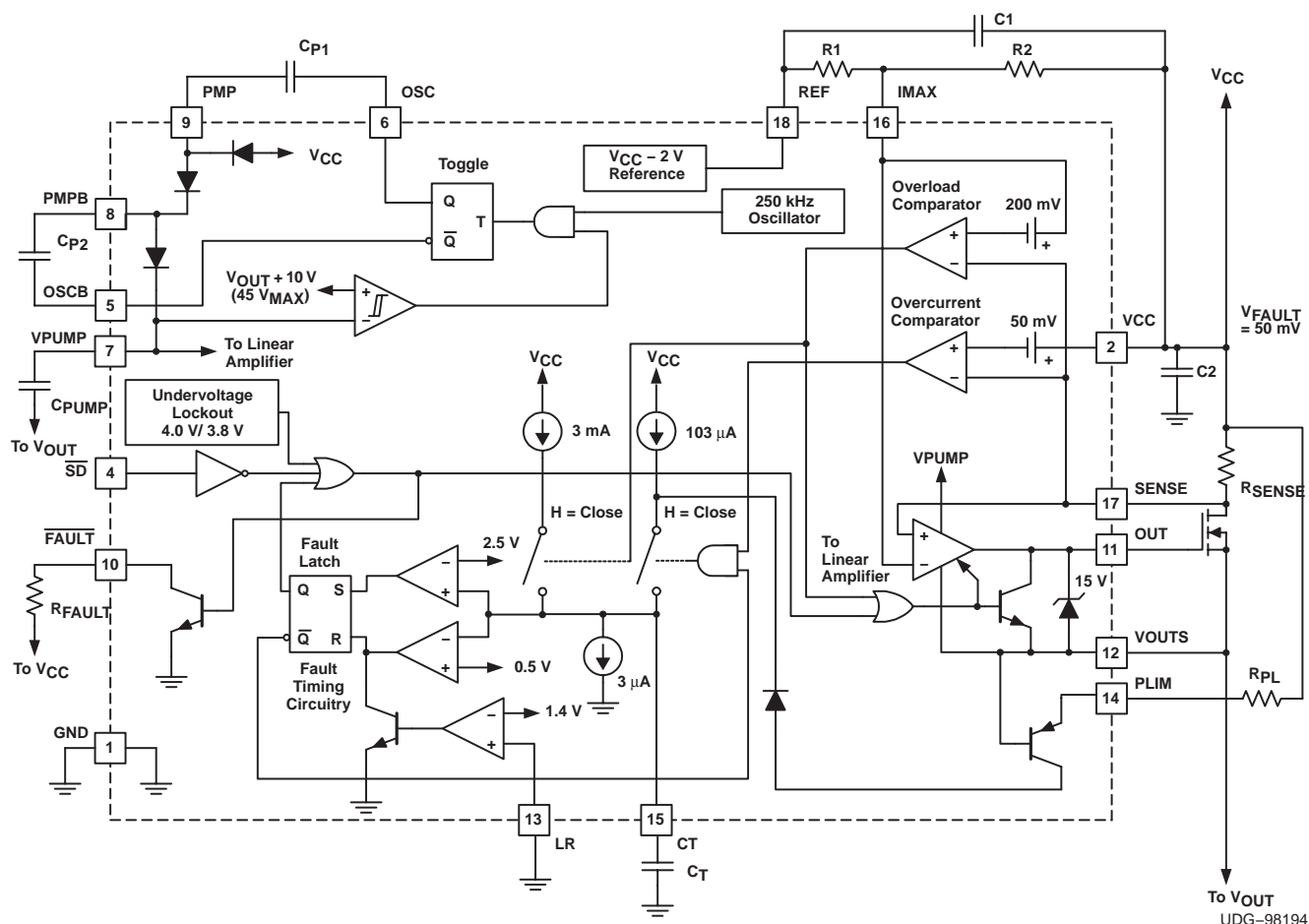

Figure 1. Typical Application

The term *hot swap* refers to the system requirement that submodules be swapped in or out upon failure or system modification without removing power to the operating hardware. The integrity of the power bus must not be compromised due to the addition of an unpowered module. Significant power bus glitches can occur due to the substantial initial charging current of on-board module bypass capacitance and other load conditions (for more information on hot swapping and power management applications, see SLUA157). The UC3914 provides protection by monitoring and controlling the output current of an external N-channel MOSFET to charge this capacitance and provide load current. The addition of the N-channel MOSFET, a sense resistor,  $R_{SENSE}$ , and two other resistors,  $R_1$  and  $R_2$ , sets the programmed maximum current level the N-channel MOSFET can source to charge the load in a controlled manner. The equation for this current,  $I_{MAX}$ , is:

$$I_{MAX} = \frac{V_{VCC} - V_{IMAX}}{R_{SENSE}} \quad (4)$$

where

- $V_{IMAX}$  is the voltage generated at the IMAX pin

PRODUCT PREVIEW

**APPLICATION INFORMATION**

Analysis of the application circuit shows that  $V_{IMAX}$  (with respect to GND) can be defined as:

$$V_{IMAX} = V_{REF} + \frac{(V_{CC} - V_{REF}) \times R1}{R1 + R2} = \frac{2V \times R1}{R1 + R2} + V_{REF} \tag{5}$$

where

- $V_{REF}$  is the voltage on the REF pin, an internally generated potential 2-V below  $V_{CC}$

The UC3914 also has an internal overcurrent comparator which monitors the voltage between SENSE and  $V_{CC}$ . If this voltage exceeds 50 mV, the comparator determines that a fault has occurred, and a timing capacitor,  $C_T$ , begins to charge. This can be rewritten as a current which causes a fault,  $I_{FAULT}$ :

$$I_{FAULT} = \frac{50 \text{ mV}}{R_{SENSE}} \tag{6}$$

**FAULT TIMING**

Figure 2 shows the circuitry associated with the fault timing function of the UC3914. A typical fault mode, where the overload comparator and current source  $I_3$  do not factor into operation (switch  $S_2$  is open), is first considered. Once the voltage across  $R_{SENSE}$  exceeds 50 mV, a fault has occurred. This causes the timing capacitor,  $C_T$ , to charge with a combination of 100  $\mu\text{A}$  ( $I_1$ ) plus the current from the power limiting circuitry ( $I_{PL}$ ).

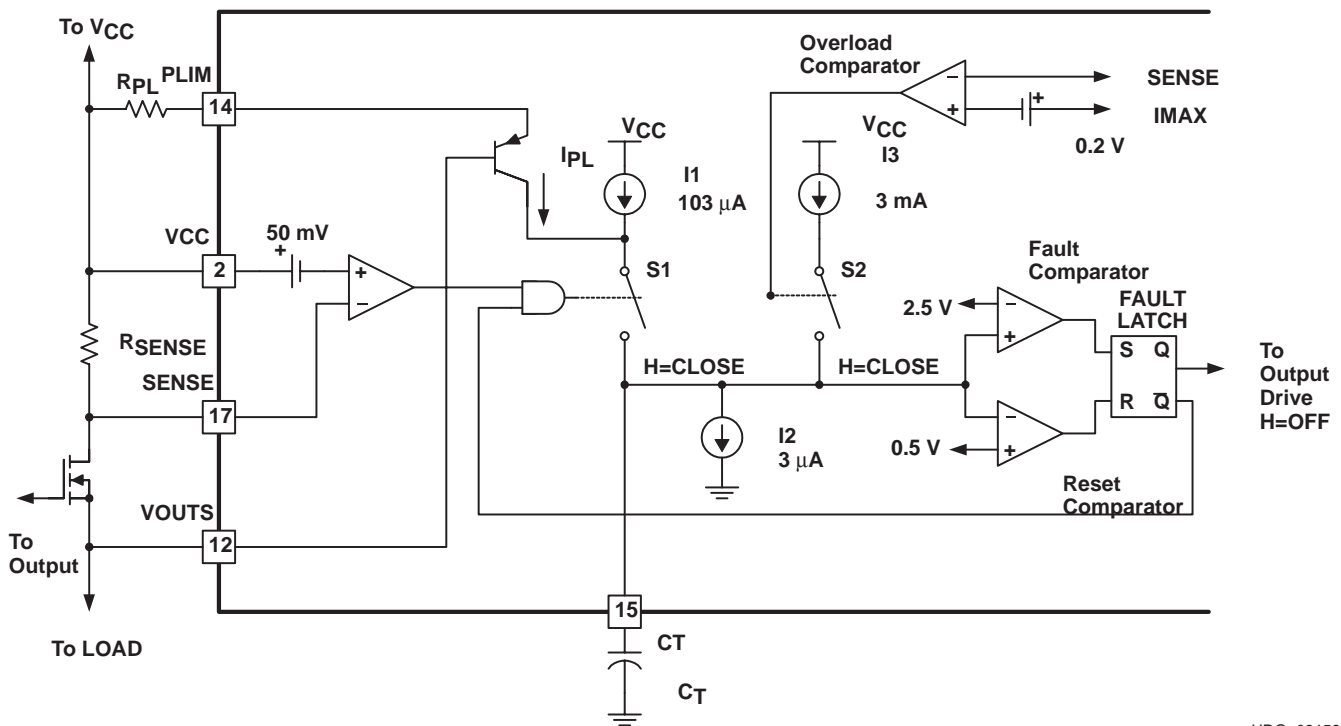
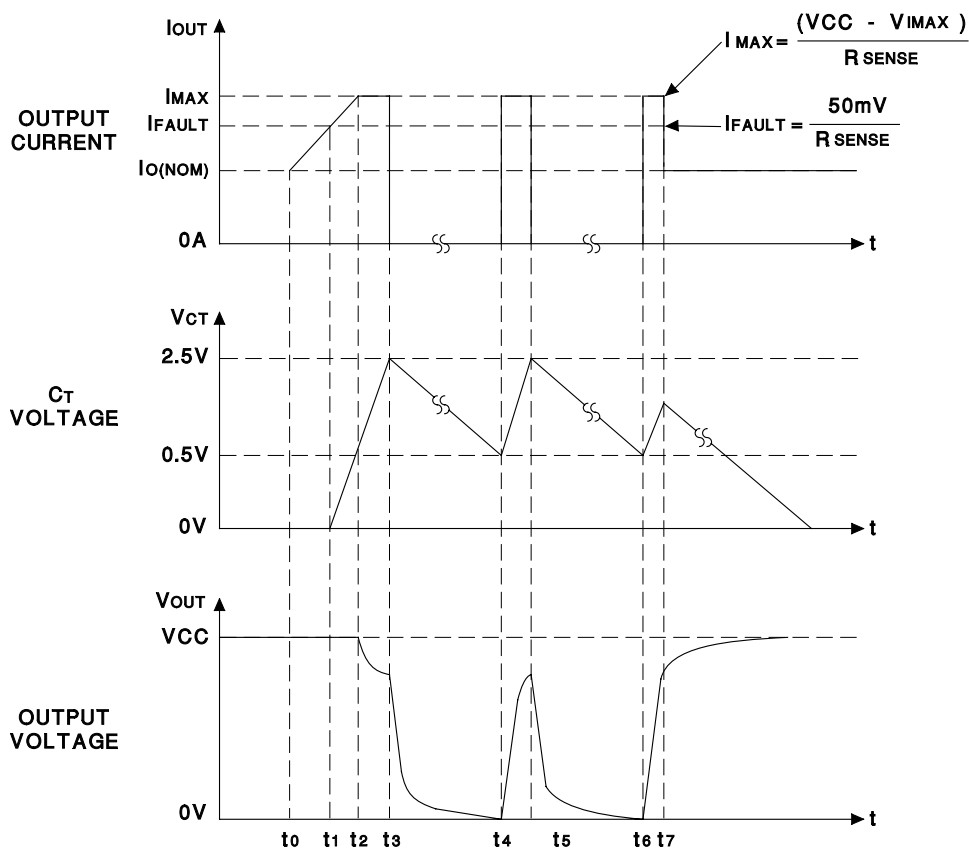

**Figure 2. Fault Timing Circuitry Including Power Limit and Overcurrent**

UDG-03158

APPLICATION INFORMATION

Figure 3 shows typical fault timing waveforms for the external N-channel MOSFET output current, the voltage on the CT pin, and the output load voltage,  $V_{OUT}$ , with LR left floating or grounded.



UDG-97054

Figure 3. Typical Timing Diagram

Table 1. Fault Timing Conditions

TIME	CONDITION
t0	Normal conditions. Output current is nominal, output voltage is at positive rail, VCC
t1	Fault control reached. Output current rises above the programmed fault value, $C_T$ begins to charge at $100\text{-}\mu\text{A} + I_{PL}$ .
t2	Maximum current reached. Output current reaches the programmed maximum level and becomes a constant current with value $I_{MAX}$ .
t3	Fault occurs. $C_T$ has charged to 2.5 V, fault output goes low, the FET turns off allowing no output current to flow, $V_{VOULTS}$ discharges to GND.
t4	Retry. $C_T$ has discharged to 0.5 V, but fault current is still exceeded, $C_T$ begins charging again, FET is on, $V_{OUT}$ increases.
t5 = t3	Illustrates < 3% duty cycle depending upon $R_{PL}$ selected.
t6=t4	
t7=t0	Fault released, normal condition. Return to normal operation of the load.

## APPLICATION INFORMATION

The output voltage waveforms have assumed an R-C characteristic load and time constants vary depending upon the component values. Prior to time  $t_0$ , the load is fully charged to almost  $V_{VCC}$  and the N-channel MOSFET is supplying the current,  $I_{OUT}$ , to the load. At  $t_0$ , the current begins to ramp up due to a change in the load conditions until, at  $t_1$ , the fault current level,  $I_{FAULT}$ , has been reached to cause switch S1 to close. This results in  $C_T$  being charged with the current sources  $I_1$  and  $I_{PL}$ . During this time,  $V_{OUT}$  remains almost equal to  $V_{VCC}$  except for small losses from voltage drops across the sense resistor and the N-channel MOSFET. The output current reaches the programmed maximum level,  $I_{MAX}$ , at  $t_2$ . The  $C_T$  voltage continues to rise since  $I_{MAX}$  is still greater than  $I_{FAULT}$ . The load output voltage drops because the current load requirements have become greater than the controlled maximum sourcing current. The  $C_T$  voltage reaches the upper comparator threshold (Figure 2) of 2.5 V at  $t_3$ , which promptly shuts off the gate drive to the N-channel MOSFET (not shown but can be inferred from the fact that no output current is provided to the load), latches in the fault and opens switch S1 disconnecting the charging currents  $I_1$  and  $I_{PL}$  from  $C_T$ .

Since no output current is supplied, the load voltage decays at a rate determined by the load characteristics and the capacitance. The 3- $\mu$ A current source,  $I_2$ , discharges  $C_T$  to the 0.5-V reset comparator threshold. This time is significantly longer than the charging time and is the basis for the duty cycle current limiting technique. When the  $C_T$  voltage reaches 0.5 V at  $t_4$ , the part performs a retry, allowing the N-channel MOSFET to again source current to the load and cause  $V_{OUT}$  to rise. In this particular example,  $I_{MAX}$  is still sourced by the N-channel MOSFET at each attempted retry and the fault timing sequence is repeated until time  $t_7$  when the load requirements change to  $I_{OUT}$ . Since  $I_{OUT}$  is less than the fault current level at this time, switch S1 is opened,  $I_2$  discharges  $C_T$  and  $V_{OUT}$  rises almost to the level of  $V_{CC}$ .

Figure 4 shows fault timing waveforms similar to those depicted in Figure 3 except that the latch reset (LR) function is utilized. Operation is the same as described above until  $t_4$  when the voltage on  $C_T$  reaches the reset threshold. Holding LR high prevents the latch from being reset, preventing the device from performing a retry (sourcing current to the load). The UC3914 is latched off until either LR is pulled to a logic low, or the chip is forced into an under voltage lockout (UVLO) condition and back out of UVLO causing the latch to automatically perform a power on reset. Figure 4 illustrates LR being toggled low at  $t_5$ , causing the part to perform a retry. Time  $t_6$  again illustrates what happens when a fault is detected. The LR pin is toggled low and back high at time  $t_7$ , prior to the voltage on the  $C_T$  pin hitting the reset threshold. This information tells the UC3914 to allow the part to perform a retry when the lower reset threshold is reached, which occurs at  $t_8$ . Time  $t_9$  corresponds to when load conditions change to where a fault is not present as described for Figure 3.

APPLICATION INFORMATION

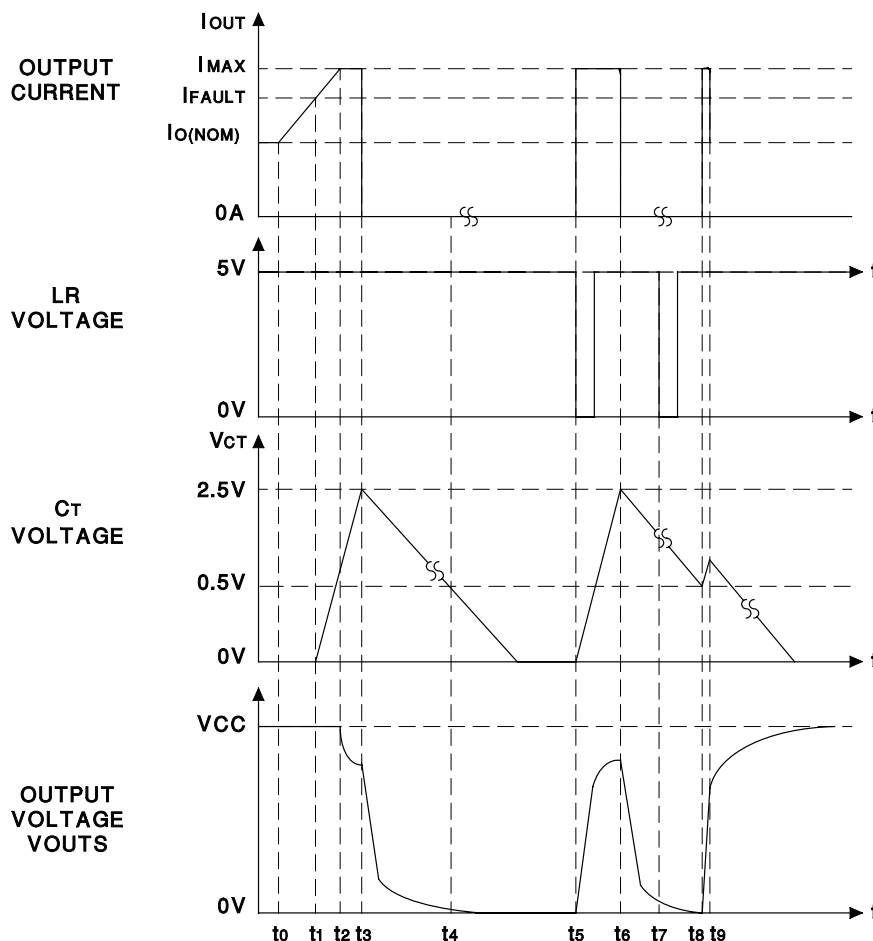

UDG-97055

Figure 4. Typical Timing Diagram Using Latch Reset (LR) Function

Table 2. Fault Timing Conditions with Latch Reset Function

TIME	CONDITION
t <sub>0</sub>	Normal conditions. Output current is nominal, output voltage is at positive rail, V <sub>CC</sub>
t <sub>1</sub>	Fault control reached. Output current rises above the programmed fault value, C <sub>T</sub> begins to charge at 100-μA + I <sub>PL</sub> .
t <sub>2</sub>	Maximum current reached. Output current reaches the programmed maximum level and becomes a constant current with value I <sub>MAX</sub> .
t <sub>3</sub>	Fault occurs. C <sub>T</sub> has charged to 2.5 V, fault output goes low, the FET turns off allowing no output current to flow, V <sub>VOUTS</sub> discharges to GND.
t <sub>4</sub>	Reset comparator threshold reached but no retry since LR pin held high.
t <sub>5</sub>	LR toggled low, N-channel MOSFET turned on and sources current to load.
t <sub>6</sub> =t <sub>3</sub>	
t <sub>7</sub>	LR toggled low before V <sub>CT</sub> reaches reset comparator threshold, causing retry.
t <sub>8</sub>	Since LR toggled low during present cycle, N-channel MOSFET turned on and sources current to load.
t <sub>9</sub> =t <sub>0</sub>	Fault released, normal condition. Return to normal operation of the load.

PRODUCT PREVIEW

## APPLICATION INFORMATION

### Power Limiting

The power limiting circuitry is designed to only source current into the CT pin. To implement this feature, a resistor,  $R_{PL}$ , should be placed between VCC and PLIM. The current,  $I_{PL}$  (shown in Figure 2) is given by the following expression:

$$I_{PL} = \frac{V_{VCC} - V_{VOUTS}}{R_{PL}}, \text{ for } V_{VOUTS} > 1 \text{ V} + V_{CT} \quad (7)$$

where

- $V_{CT}$  is the voltage on the CT pin

For  $V_{VOUTS} < 1 \text{ V} + V_{CT}$  the common mode range of the power limiting circuitry causes  $I_{PL} = 0 \text{ A}$  leaving only the 100- $\mu\text{A}$  current source to charge  $C_T$ .  $V_{VCC} - V_{VOUTS}$  represents the voltage across the N-channel MOSFET pass device.

This feature limits average power dissipation in the pass device. Note that under a fault condition where the output current is just above the fault level, but less than the maximum level,  $V_{VOUTS} \sim V_{VCC}$ ,  $I_{PL} = 0 \text{ A}$  and the  $C_T$  charging current is 100  $\mu\text{A}$ .

During a fault, the CT pin charges at a rate determined by the internal charging current and the external timing capacitor,  $C_T$ . Once  $C_T$  charges to 2.5 V, the fault comparator trips and sets the fault latch. When this occurs, OUT is pulled down to VOUTS, causing the external N-channel MOSFET to shut off and the charging switch, S1, to open.  $C_T$  is discharged with I2 until the  $V_{CT}$  potential reaches 0.5 V. Once this occurs, the fault latch resets (unless LR is being held high, whereby a fault can only be cleared by pulling this pin low or going through a power-on-reset cycle), which re-enables the output of the linear amplifier and allows the fault circuitry to regain control of the charging switch. If a fault is still present, the overcurrent comparator closes the charging switch causing the cycle to repeat. Under a constant fault the duty cycle is given by:

$$\text{Duty Cycle} = \frac{3 \mu\text{A}}{I_{PL} + 100 \mu\text{A}} \quad (8)$$

Average power dissipation can be limited using the PLIM pin. Average power dissipation in the pass element is given by:

$$\begin{aligned} P_{FET(avg)} &= (V_{VCC} - V_{VOUTS}) \times I_{MAX} \times \text{Duty Cycle} \\ &= (V_{VCC} - V_{VOUTS}) \times I_{MAX} \times \frac{3 \mu\text{A}}{I_{PL} + 100 \mu\text{A}} \end{aligned} \quad (9)$$

$V_{VCC} - V_{VOUTS}$  is the drain to source voltage across the MOSFET. When  $I_{PL} \gg 100 \mu\text{A}$ , the duty cycle equation given above can be rewritten as:

$$\text{Duty Cycle} = \frac{R_{PL} \times 3 \mu\text{A}}{(V_{VCC} - V_{VOUTS})} \quad (10)$$

and the average power dissipation of the MOSFET is given by:

$$P_{FET(avg)} = (V_{VCC} - V_{VOUTS}) \times I_{MAX} \times \frac{R_{PL} \times 3 \mu\text{A}}{(V_{VCC} - V_{VOUTS})} = I_{MAX} \times R_{PL} \times 3 \mu\text{A} \quad (11)$$

The average power is limited by the programmed  $I_{MAX}$  current and the appropriate value for  $R_{PL}$ .

## APPLICATION INFORMATION

### OVERLOAD COMPARATOR

The linear amplifier in the UC3914 ensures that the external N-channel MOSFET does not source more than the current  $I_{MAX}$ , defined in equation (4):

$$I_{MAX} = \frac{V_{VCC} - V_{IMAX}}{R_{SENSE}}$$

In the event that output current exceeds the programmed  $I_{MAX}$  current by more than  $200\text{-mV}/R_{SENSE}$ , the output of the linear amplifier is immediately pulled low (with respect to  $V_{OUTS}$ ) providing no gate drive to the N-channel MOSFET, and preventing current from being delivered to the load. This situation could occur if the external N-channel MOSFET is not responding to a command from the UC3914 or output load conditions change quickly to cause an overload condition before the linear amplifier can respond. For example, if the N-channel MOSFET is sourcing current into a load and the load suddenly becomes short circuited, an overload condition may occur. The short circuit causes the  $V_{GS}$  of the N-channel MOSFET to immediately increase, resulting in increased load current and voltage drop across  $R_{SENSE}$ . If this drop exceeds the overload comparator threshold, the amplifier output is quickly pulled low. It also causes the CT pin to begin charging with  $I_3$ , a 3-mA current source (refer to Figure 2) and continue to charge until approximately 1-V below  $V_{VCC}$ , where it is clamped. This allows a constant fault to show up on  $\overline{FAULT}$  and since the voltage on CT charges past 2.5 V only in an overload fault condition, it can be used for detection of output N-channel MOSFET failure or to build redundancy into the system.

### ESTIMATING MINIMUM TIMING CAPACITANCE

The startup time of the device may not exceed the fault time for the application. Since the timing capacitor,  $C_T$ , determines the fault time, its minimum value can be determined by calculating the startup time of the device. The startup time is dependent upon several external components. A load capacitor,  $C_{LOAD}$ , should be tied between  $V_{OUTS}$  and GND. Its value should be greater than that of  $C_{PUMP}$ , the reservoir capacitor tied from  $V_{PUMP}$  to  $V_{OUTS}$  (see Figure 4). Given values of  $C_{LOAD}$ ,  $R_{LOAD}$ ,  $R_{SENSE}$ ,  $V_{VCC}$  and the resistors determining the voltage on  $I_{MAX}$ , the user can calculate the approximate startup time of the node  $V_{OUT}$ . This time must be less than the time it takes for CT to charge to 2.5 V. Assuming the user has determined the fault current,  $R_{SENSE}$  can be calculated by:

$$R_{SENSE} = \frac{50 \text{ mV}}{I_{FAULT}} \quad (12)$$

$I_{MAX}$  is the maximum current the UC3914 allows through the transistor, M1. During startup with an output capacitor, M1 can be modeled as a constant current source of value  $I_{MAX}$  using equation (4).

Given this information, calculation of startup time is now possible via the following:

Using a constant-current load model, use this equation:

$$T_{START} = \frac{(C_{LOAD} \times V_{VCC})}{(I_{MAX} - I_{LOAD})} \quad (13)$$

Using a resistive load model, use this equation:

$$T_{START} = -R_{LOAD} \times C_{LOAD} \times \ln \left( 1 - \frac{V_{VCC}}{I_{MAX} \times R_{LOAD}} \right) \quad (14)$$

## APPLICATION INFORMATION

The only remaining external component which may affect the minimum timing capacitor is the optional power limiting resistor,  $R_{PL}$ . If the addition of  $R_{PL}$  is desirable, its value can be determined from the *Power Limiting* section of this datasheet. The minimum timing capacitor values are now given by the following equations.

Using a constant-current load model, use this equation:

$$CT_{\min} = T_{\text{START}} \times \left[ \frac{10^{-4} \times R_{PL} + \left( \frac{V_{VCC}}{2} \right)}{2 \times R_{PL}} \right] \quad (15)$$

Using a resistive load model, use this equation:

$$CT_{(\min)} = \frac{\left( 10^{-4} \times R_{PL} + V_{VCC} - (I_{\text{MAX}} \times R_{\text{LOAD}}) \right) \times T_{\text{START}}}{2 \times R_{PL}} + \frac{V_{VCC}}{2 \times R_{PL}} \times R_{\text{LOAD}} \times C_{\text{LOAD}} \quad (16)$$

## OUTPUT CURRENT SOFTSTART

The external MOSFET output current can be increased at a user-defined rate to ensure that the output voltage comes up in a controlled fashion by adding capacitor  $C_{SS}$ , as shown in Figure 5. The one constraint that the UC3914 places on the soft-start time is that the charge pump time constant must be much less than the soft-start time constant to ensure proper soft-start operation. The time constant determining the startup time of the charge pump is given by:

$$\tau_{CP} = R_{\text{OUT}} \times C_{\text{PUMP}} \quad (17)$$

$R_{\text{OUT}}$  is the output impedance of the charge pump given by:

$$R_{\text{OUT}} = \frac{1}{f_{\text{PUMP}} \times C_P} \quad (18)$$

where  $f_{\text{PUMP}}$  is the charge pump frequency (125 kHz) and  $C_P = C_{P1} = C_{P2}$  are the charge pump flying capacitors. For typical values of  $C_{P1}$ ,  $C_{P2}$  and  $C_{\text{PUMP}}$  (0.01- $\mu\text{F}$ ) and a switching frequency of 125 kHz, the output impedance is 800  $\Omega$  and the charge pump time constant is 8  $\mu\text{s}$ . The charge pump should be close to being fully charged in 3 time constants or 24  $\mu\text{s}$ . By placing a capacitor from VCC to IMAX, the voltage at IMAX, which sets the maximum output current of the MOSFET, exponentially decays from VCC to the desired value set by R1 and R2. The output current of the MOSFET is controlled via soft-start as long as the soft-start time constant ( $\tau_{SS}$ ) is much greater than the charge pump time constant  $\tau_{CP}$ , given by:

$$\tau_{SS} = (R1 \parallel R2) \times C_{SS} \quad (19)$$

APPLICATION INFORMATION

MINIMIZING TOTAL DROPOUT UNDER LOW VOLTAGE OPERATION

In a typical application, the UC3914 is used to control the output current of an external N-channel MOSFET during hot swapping situations. Once the load has been fully charged, the desired output voltage on the load,  $V_{OUT}$ , needs to be as close to  $V_{CC}$  as possible to minimize total dropout. For a resistive load,  $R_{LOAD}$ , the output voltage is given by:

$$V_{OUT} = \frac{R_{LOAD}}{R_{LOAD} + R_{SENSE} + R_{DS(on)}} \times V_{VCC} \tag{20}$$

$R_{SENSE}$  sets the fault current,  $I_{FAULT}$ .  $R_{DS(on)}$ , the on-resistance of the N-channel MOSFET, should be made as small as possible to ensure  $V_{OUT}$  is as close to  $V_{CC}$  as possible. For a given N-channel MOSFET, the manufacturer specifies the  $R_{DS(on)}$  for a certain  $V_{GS}$  (i. e., between 7 V to 10 V). The source potential of the N-channel MOSFET is  $V_{OUT}$ . In order to ensure sufficient  $V_{GS}$ , this requires the gate of the N-channel MOSFET, which is the output of the linear amplifier, to be many volts higher than  $V_{VCC}$ . The UC3914 provides the capability to generate this voltage through the addition of three capacitors,  $C_{P1}$ ,  $C_{P2}$  and  $C_{PUMP}$  as shown in Figure 6. These capacitors should be used in conjunction with the complementary output drivers and internal diodes included on-chip to create a charge pump or voltage tripler. The circuit boosts  $V_{VCC}$  by utilizing capacitors  $C_{P1}$ ,  $C_{P2}$  and  $C_{PUMP}$  in such a way that the voltage at  $VPUMP$  approximately equals three times the voltage at  $V_{CC}$  minus five times the voltage drop of the diodes, almost tripling the input supply voltage to the device.

$$V_{VPUMP} = (3 \times V_{VCC}) - (5 \times V_{DIODE}) \tag{21}$$

On each complete cycle,  $C_{P1}$  is charged to approximately  $(V_{VCC} - V_{DIODE})$  (unless  $V_{CC}$  is greater than 15 V causing internal clamping to limit this charging voltage to about 13 V) when the output Q of the toggle flip-flop is low. When  $\bar{Q}$  is transitioned low (and Q correspondingly is brought high), the negative side of  $C_{P2}$  is pulled to ground, and  $C_{P1}$  charges  $C_{P2}$  up to approximately:

$$V_{CP2} = (2 \times V_{VCC}) - (3 \times V_{DIODE}) \tag{22}$$

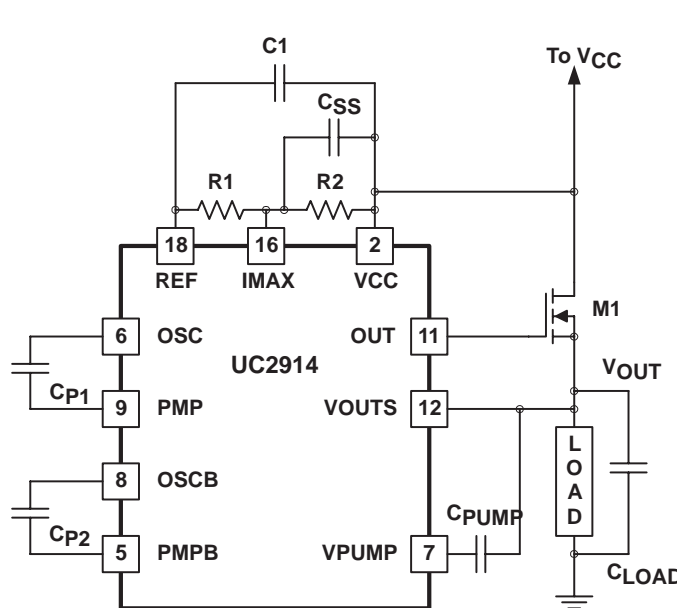

Figure 5. MOSFET Softstart Diagram

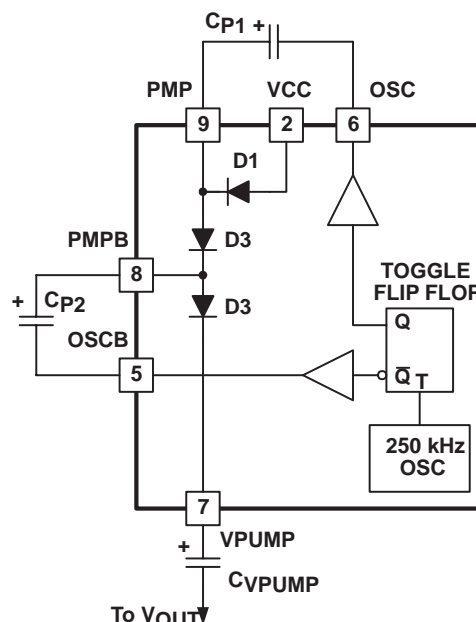

Figure 6. Charge Pump Block Diagram

UDG-03178



## APPLICATION INFORMATION

Operation is similar to the case described above. This additional circuitry is not necessary for higher input voltages because the UC3914 has internal clamping which only allows  $V_{PUMP}$  to be 10 V greater than  $V_{OUTS}$ .

Table 3 characterizes the UCx914 charge pump in its standard configuration, with external schottky diodes, and configured as a voltage quadrupler.

**NOTE:** The voltage quadrupler is unnecessary for input voltages above 7.0 V due to the internal clamping action.

**Table 3. Charge Pump Characteristics**

INPUT VOLTAGE (V <sub>CC</sub> )	INTERNAL DIODES (V <sub>GS</sub> )	EXTERNAL SCHOTTKY DIODES (V <sub>GS</sub> )	QUADRUPLER (V <sub>GS</sub> )
4.5	4.57	6.8	8.7
5.0	5.80	7.9	8.8
5.5	6.60	8.6	8.9
6.0	7.60	8.8	9.0
6.5	8.70	8.8	9.0
7.0	8.80	9.0	9.0
9.0	9.20	9.4	9.1
10.0	9.30	9.4	9.3

## I<sub>CC</sub> SPECIFICATIONS

The I<sub>CC</sub> operating measurement is actually a mathematical calculation. The charge pump voltage is constantly being monitored with respect to both V<sub>CC</sub> and V<sub>OUTS</sub> to determine whether the pump requires servicing. If there is insufficient voltage on this pin, the charge pump drivers are alternately switched to raise the voltage of the pump (see Figure 9). Once the voltage on the pump is high enough, the drivers and other charge pump related circuitry are shutdown to conserve current. The pump voltage decays due to internal loading until it reaches a low enough level to turn the drivers back on. The chip requires significantly different amounts of current during these two modes of operation and the following mathematical calculation is used to calculate the average current:

$$I_{CC} = \frac{I_{CC\text{drivers(on)}} \times T_{ON} + I_{CC\text{drivers(off)}} \times T_{OFF}}{T_{ON} + T_{OFF}} \quad (26)$$

Since the charge pump does not always require servicing, the user may think that the charge pump frequency is much less than the datasheet specification. This is not the case as the free-running frequency is guaranteed to be within the datasheet limits. The charge pump servicing frequency can make it appear as though the drivers are operating at a much lower frequency

APPLICATION INFORMATION

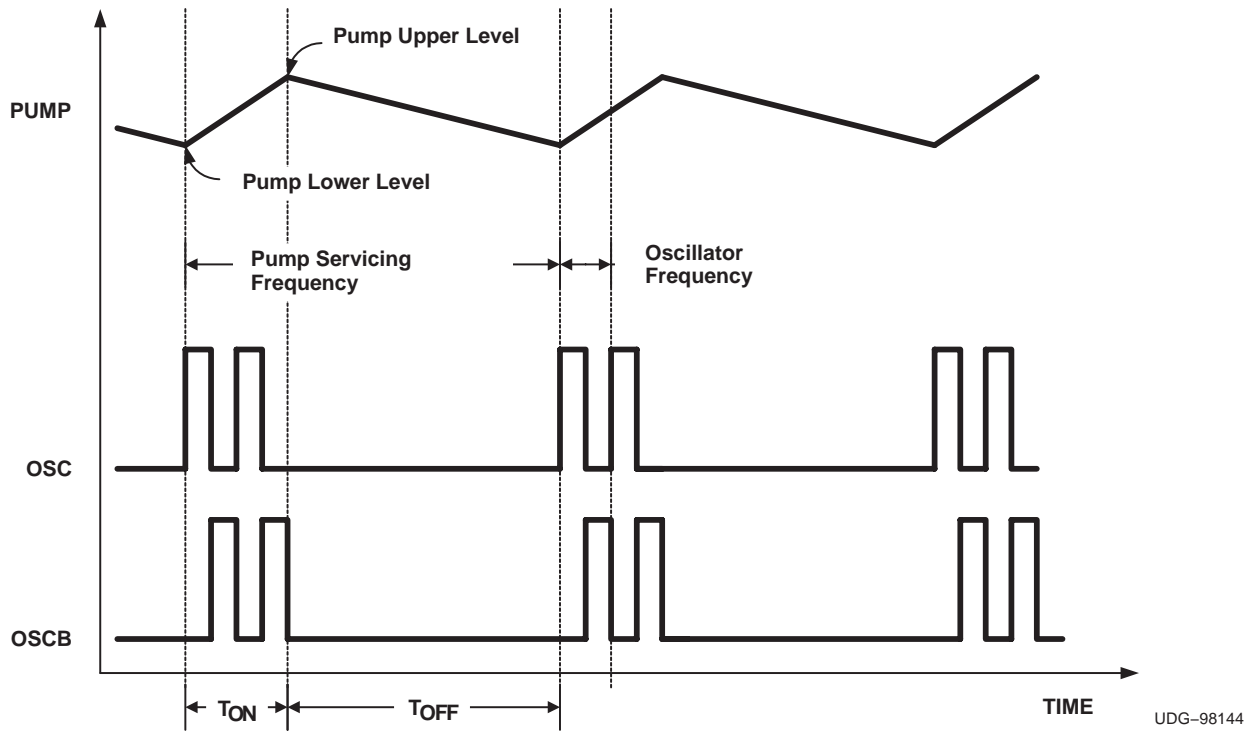

Figure 9. Charge Pump Waveforms

PRODUCT PREVIEW

UDG-98144

TYPICAL CHARACTERISTICS

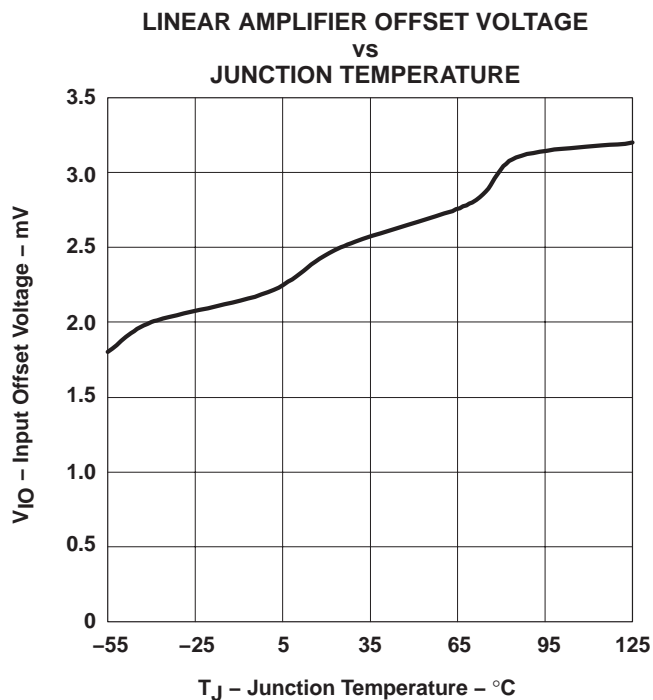

Figure 10

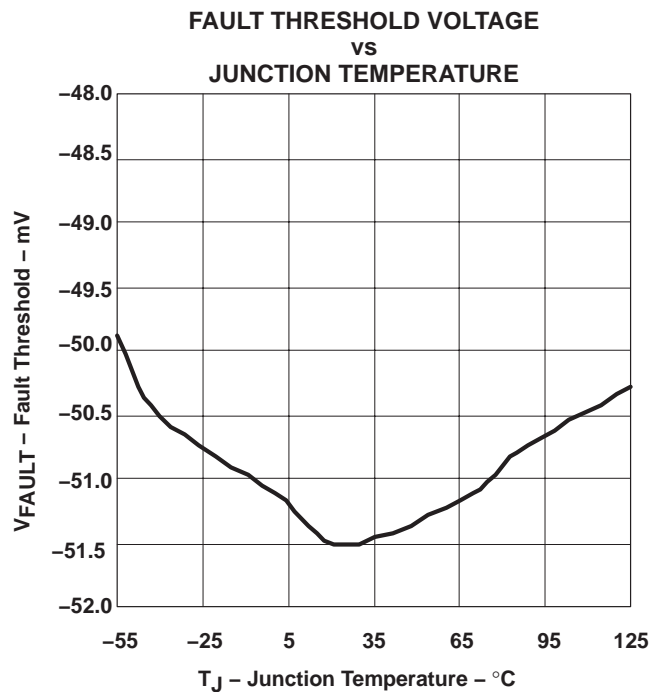

Figure 11

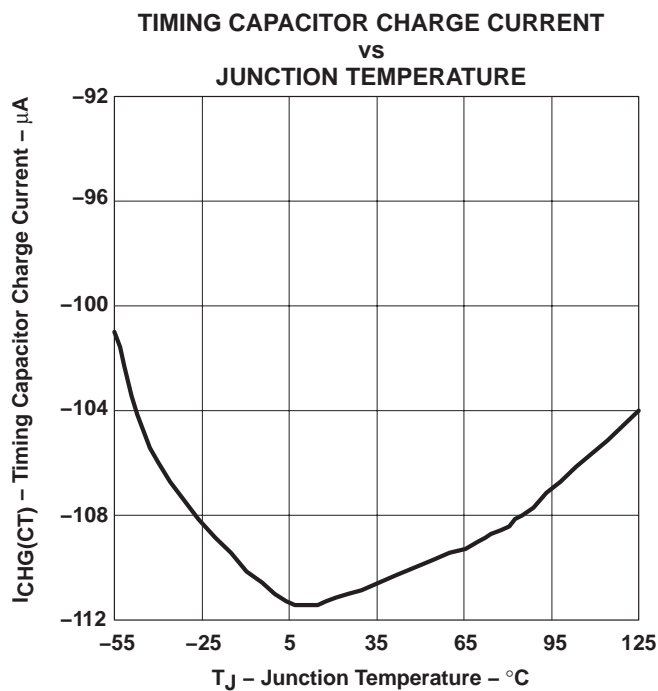

Figure 12

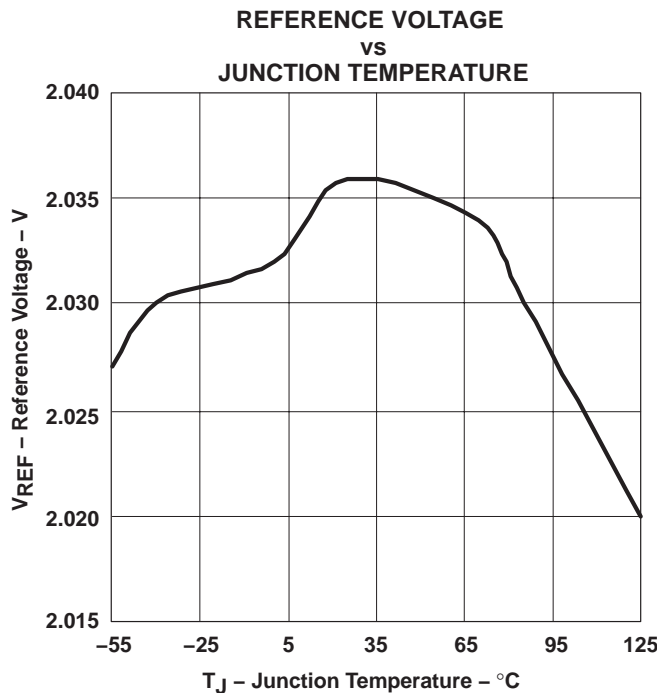

Figure 13

PRODUCT PREVIEW

TYPICAL CHARACTERISTICS

INPUT BIAS CURRENT  
vs  
JUNCTION TEMPERATURE

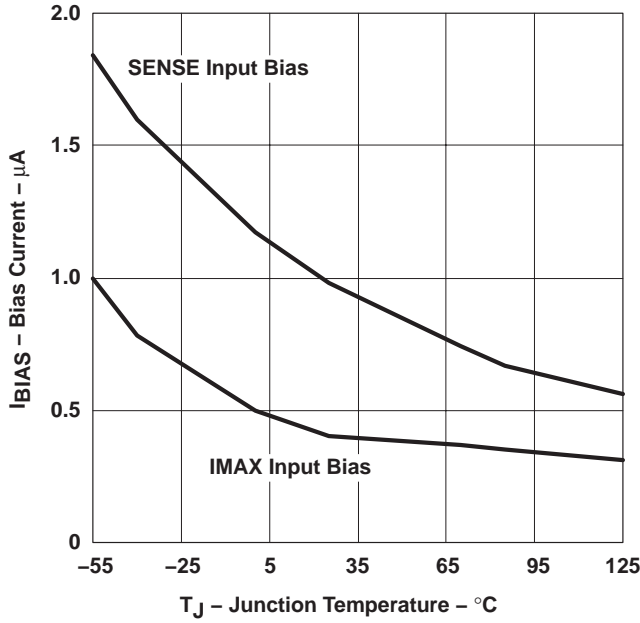

Figure 14

TIMING CAPACITOR DISCHARGE CURRENT  
vs  
JUNCTION TEMPERATURE

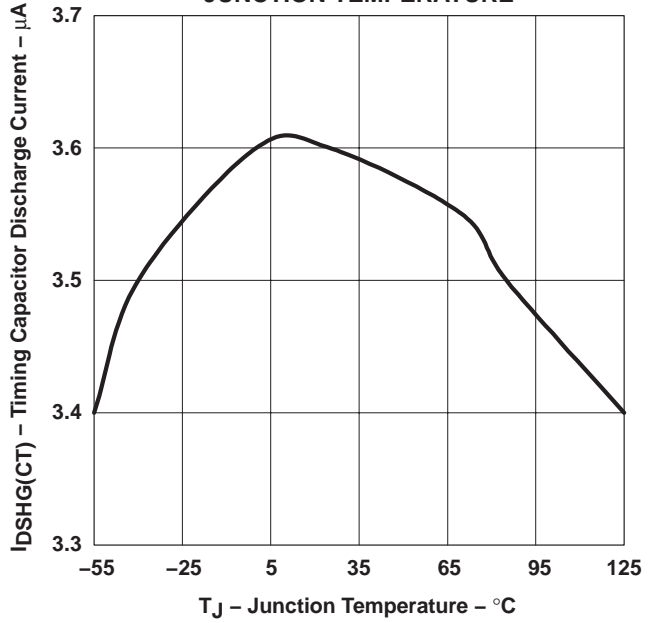

Figure 15

SAFETY RECOMMENDATIONS

Although the UC3914 is designed to provide system protection for all fault conditions, all integrated circuits can ultimately fail short. For this reason, if the UC3914 is intended for use in safety critical applications where UL<sup>®</sup> or some other safety rating is required, a redundant safety device such as a fuse should be placed in series with the device. The UC3914 prevents the fuse from blowing in virtually all fault conditions, increasing system reliability and reducing maintenance cost, in addition to providing the hot swap benefits of the device.

PRODUCT PREVIEW

**PACKAGING INFORMATION**

Orderable Device	Status (1)	Package Type	Package Drawing	Pins	Package Qty	Eco Plan (2)	Lead/Ball Finish (6)	MSL Peak Temp (3)	Op Temp (°C)	Device Marking (4/5)	Samples
UC2914DW	ACTIVE	SOIC	DW	18	40	Green (RoHS & no Sb/Br)	CU NIPDAU	Level-2-260C-1 YEAR	-40 to 85	UC2914DW	<a href="#">Samples</a>
UC2914DWTR	ACTIVE	SOIC	DW	18	2000	Green (RoHS & no Sb/Br)	CU NIPDAU	Level-2-260C-1 YEAR	-40 to 85	UC2914DW	<a href="#">Samples</a>
UC3914DW	ACTIVE	SOIC	DW	18	40	Green (RoHS & no Sb/Br)	CU NIPDAU	Level-2-260C-1 YEAR	0 to 70	UC3914DW	<a href="#">Samples</a>
UC3914DWTR	ACTIVE	SOIC	DW	18	2000	Green (RoHS & no Sb/Br)	CU NIPDAU	Level-2-260C-1 YEAR	0 to 70	UC3914DW	<a href="#">Samples</a>
UC3914DWTRG4	ACTIVE	SOIC	DW	18	2000	Green (RoHS & no Sb/Br)	CU NIPDAU	Level-2-260C-1 YEAR	0 to 70	UC3914DW	<a href="#">Samples</a>

(1) The marketing status values are defined as follows:

**ACTIVE:** Product device recommended for new designs.

**LIFEBUY:** TI has announced that the device will be discontinued, and a lifetime-buy period is in effect.

**NRND:** Not recommended for new designs. Device is in production to support existing customers, but TI does not recommend using this part in a new design.

**PREVIEW:** Device has been announced but is not in production. Samples may or may not be available.

**OBSOLETE:** TI has discontinued the production of the device.

(2) Eco Plan - The planned eco-friendly classification: Pb-Free (RoHS), Pb-Free (RoHS Exempt), or Green (RoHS & no Sb/Br) - please check <http://www.ti.com/productcontent> for the latest availability information and additional product content details.

**TBD:** The Pb-Free/Green conversion plan has not been defined.

**Pb-Free (RoHS):** TI's terms "Lead-Free" or "Pb-Free" mean semiconductor products that are compatible with the current RoHS requirements for all 6 substances, including the requirement that lead not exceed 0.1% by weight in homogeneous materials. Where designed to be soldered at high temperatures, TI Pb-Free products are suitable for use in specified lead-free processes.

**Pb-Free (RoHS Exempt):** This component has a RoHS exemption for either 1) lead-based flip-chip solder bumps used between the die and package, or 2) lead-based die adhesive used between the die and leadframe. The component is otherwise considered Pb-Free (RoHS compatible) as defined above.

**Green (RoHS & no Sb/Br):** TI defines "Green" to mean Pb-Free (RoHS compatible), and free of Bromine (Br) and Antimony (Sb) based flame retardants (Br or Sb do not exceed 0.1% by weight in homogeneous material)

(3) MSL, Peak Temp. - The Moisture Sensitivity Level rating according to the JEDEC industry standard classifications, and peak solder temperature.

(4) There may be additional marking, which relates to the logo, the lot trace code information, or the environmental category on the device.

(5) Multiple Device Markings will be inside parentheses. Only one Device Marking contained in parentheses and separated by a "~" will appear on a device. If a line is indented then it is a continuation of the previous line and the two combined represent the entire Device Marking for that device.

<sup>(6)</sup> Lead/Ball Finish - Orderable Devices may have multiple material finish options. Finish options are separated by a vertical ruled line. Lead/Ball Finish values may wrap to two lines if the finish value exceeds the maximum column width.

**Important Information and Disclaimer:**The information provided on this page represents TI's knowledge and belief as of the date that it is provided. TI bases its knowledge and belief on information provided by third parties, and makes no representation or warranty as to the accuracy of such information. Efforts are underway to better integrate information from third parties. TI has taken and continues to take reasonable steps to provide representative and accurate information but may not have conducted destructive testing or chemical analysis on incoming materials and chemicals. TI and TI suppliers consider certain information to be proprietary, and thus CAS numbers and other limited information may not be available for release.

In no event shall TI's liability arising out of such information exceed the total purchase price of the TI part(s) at issue in this document sold by TI to Customer on an annual basis.

## TAPE AND REEL INFORMATION



### QUADRANT ASSIGNMENTS FOR PIN 1 ORIENTATION IN TAPE



\*All dimensions are nominal

Device	Package Type	Package Drawing	Pins	SPQ	Reel Diameter (mm)	Reel Width W1 (mm)	A0 (mm)	B0 (mm)	K0 (mm)	P1 (mm)	W (mm)	Pin1 Quadrant
UC2914DWTR	SOIC	DW	18	2000	330.0	24.4	10.9	12.0	2.7	12.0	24.0	Q1
UC3914DWTR	SOIC	DW	18	2000	330.0	24.4	10.9	12.0	2.7	12.0	24.0	Q1

**TAPE AND REEL BOX DIMENSIONS**

\*All dimensions are nominal

Device	Package Type	Package Drawing	Pins	SPQ	Length (mm)	Width (mm)	Height (mm)
UC2914DWTR	SOIC	DW	18	2000	367.0	367.0	45.0
UC3914DWTR	SOIC	DW	18	2000	367.0	367.0	45.0

DW (R-PDSO-G18)

PLASTIC SMALL OUTLINE

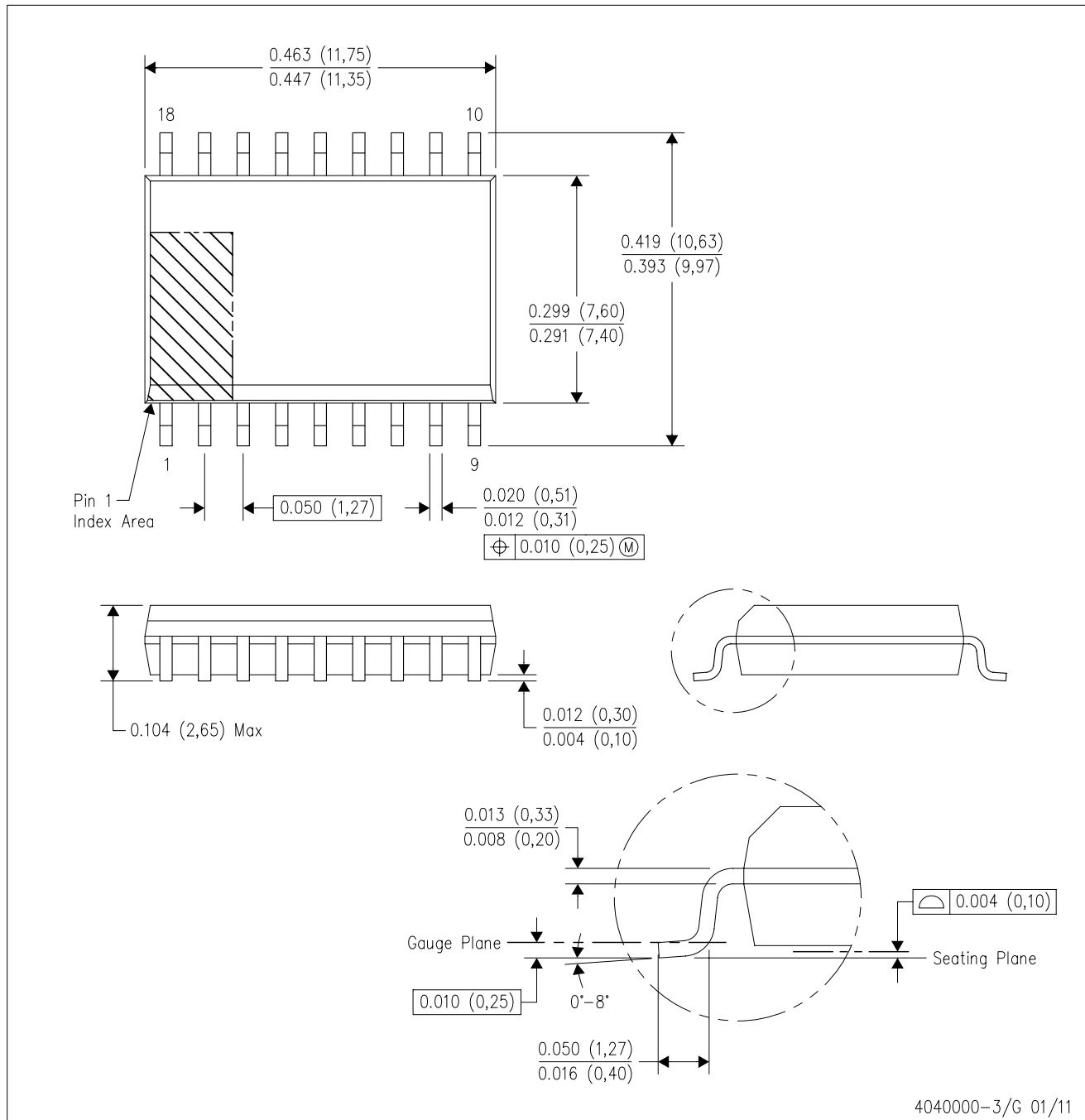

- NOTES:
- A. All linear dimensions are in inches (millimeters). Dimensioning and tolerancing per ASME Y14.5M-1994.
  - B. This drawing is subject to change without notice.
  - C. Body dimensions do not include mold flash or protrusion not to exceed 0.006 (0,15).
  - D. Falls within JEDEC MS-013 variation AB.

DW (R-PDSO-G18)

PLASTIC SMALL OUTLINE

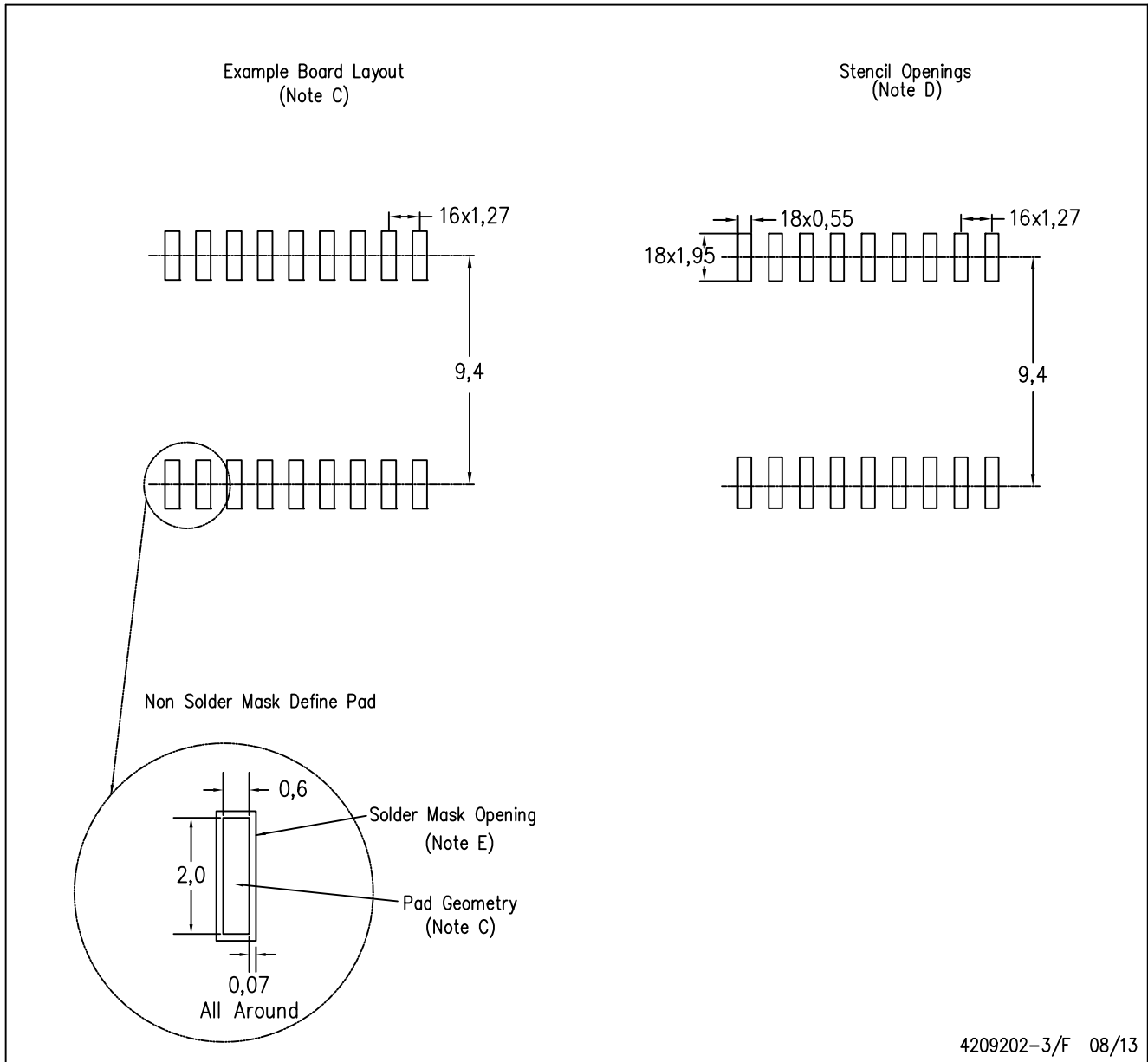

4209202-3/F 08/13

- NOTES:
- A. All linear dimensions are in millimeters.
  - B. This drawing is subject to change without notice.
  - C. Refer to IPC7351 for alternate board design.
  - D. Laser cutting apertures with trapezoidal walls and also rounding corners will offer better paste release. Customers should contact their board assembly site for stencil design recommendations. Refer to IPC-7525
  - E. Customers should contact their board fabrication site for solder mask tolerances between and around signal pads.

## IMPORTANT NOTICE

Texas Instruments Incorporated and its subsidiaries (TI) reserve the right to make corrections, enhancements, improvements and other changes to its semiconductor products and services per JESD46, latest issue, and to discontinue any product or service per JESD48, latest issue. Buyers should obtain the latest relevant information before placing orders and should verify that such information is current and complete. All semiconductor products (also referred to herein as "components") are sold subject to TI's terms and conditions of sale supplied at the time of order acknowledgment.

TI warrants performance of its components to the specifications applicable at the time of sale, in accordance with the warranty in TI's terms and conditions of sale of semiconductor products. Testing and other quality control techniques are used to the extent TI deems necessary to support this warranty. Except where mandated by applicable law, testing of all parameters of each component is not necessarily performed.

TI assumes no liability for applications assistance or the design of Buyers' products. Buyers are responsible for their products and applications using TI components. To minimize the risks associated with Buyers' products and applications, Buyers should provide adequate design and operating safeguards.

TI does not warrant or represent that any license, either express or implied, is granted under any patent right, copyright, mask work right, or other intellectual property right relating to any combination, machine, or process in which TI components or services are used. Information published by TI regarding third-party products or services does not constitute a license to use such products or services or a warranty or endorsement thereof. Use of such information may require a license from a third party under the patents or other intellectual property of the third party, or a license from TI under the patents or other intellectual property of TI.

Reproduction of significant portions of TI information in TI data books or data sheets is permissible only if reproduction is without alteration and is accompanied by all associated warranties, conditions, limitations, and notices. TI is not responsible or liable for such altered documentation. Information of third parties may be subject to additional restrictions.

Resale of TI components or services with statements different from or beyond the parameters stated by TI for that component or service voids all express and any implied warranties for the associated TI component or service and is an unfair and deceptive business practice. TI is not responsible or liable for any such statements.

Buyer acknowledges and agrees that it is solely responsible for compliance with all legal, regulatory and safety-related requirements concerning its products, and any use of TI components in its applications, notwithstanding any applications-related information or support that may be provided by TI. Buyer represents and agrees that it has all the necessary expertise to create and implement safeguards which anticipate dangerous consequences of failures, monitor failures and their consequences, lessen the likelihood of failures that might cause harm and take appropriate remedial actions. Buyer will fully indemnify TI and its representatives against any damages arising out of the use of any TI components in safety-critical applications.

In some cases, TI components may be promoted specifically to facilitate safety-related applications. With such components, TI's goal is to help enable customers to design and create their own end-product solutions that meet applicable functional safety standards and requirements. Nonetheless, such components are subject to these terms.

No TI components are authorized for use in FDA Class III (or similar life-critical medical equipment) unless authorized officers of the parties have executed a special agreement specifically governing such use.

Only those TI components which TI has specifically designated as military grade or "enhanced plastic" are designed and intended for use in military/aerospace applications or environments. Buyer acknowledges and agrees that any military or aerospace use of TI components which have **not** been so designated is solely at the Buyer's risk, and that Buyer is solely responsible for compliance with all legal and regulatory requirements in connection with such use.

TI has specifically designated certain components as meeting ISO/TS16949 requirements, mainly for automotive use. In any case of use of non-designated products, TI will not be responsible for any failure to meet ISO/TS16949.

### Products

Audio	<a href="http://www.ti.com/audio">www.ti.com/audio</a>
Amplifiers	<a href="http://amplifier.ti.com">amplifier.ti.com</a>
Data Converters	<a href="http://dataconverter.ti.com">dataconverter.ti.com</a>
DLP® Products	<a href="http://www.dlp.com">www.dlp.com</a>
DSP	<a href="http://dsp.ti.com">dsp.ti.com</a>
Clocks and Timers	<a href="http://www.ti.com/clocks">www.ti.com/clocks</a>
Interface	<a href="http://interface.ti.com">interface.ti.com</a>
Logic	<a href="http://logic.ti.com">logic.ti.com</a>
Power Mgmt	<a href="http://power.ti.com">power.ti.com</a>
Microcontrollers	<a href="http://microcontroller.ti.com">microcontroller.ti.com</a>
RFID	<a href="http://www.ti-rfid.com">www.ti-rfid.com</a>
OMAP Applications Processors	<a href="http://www.ti.com/omap">www.ti.com/omap</a>
Wireless Connectivity	<a href="http://www.ti.com/wirelessconnectivity">www.ti.com/wirelessconnectivity</a>

### Applications

Automotive and Transportation	<a href="http://www.ti.com/automotive">www.ti.com/automotive</a>
Communications and Telecom	<a href="http://www.ti.com/communications">www.ti.com/communications</a>
Computers and Peripherals	<a href="http://www.ti.com/computers">www.ti.com/computers</a>
Consumer Electronics	<a href="http://www.ti.com/consumer-apps">www.ti.com/consumer-apps</a>
Energy and Lighting	<a href="http://www.ti.com/energy">www.ti.com/energy</a>
Industrial	<a href="http://www.ti.com/industrial">www.ti.com/industrial</a>
Medical	<a href="http://www.ti.com/medical">www.ti.com/medical</a>
Security	<a href="http://www.ti.com/security">www.ti.com/security</a>
Space, Avionics and Defense	<a href="http://www.ti.com/space-avionics-defense">www.ti.com/space-avionics-defense</a>
Video and Imaging	<a href="http://www.ti.com/video">www.ti.com/video</a>

### TI E2E Community

[e2e.ti.com](http://e2e.ti.com)