

REGULATING PULSE WIDTH MODULATORS

FEATURES

- 8-V to 35-V Operation
- 5.1-V Reference Trimmed to 1%
- 100-Hz to 500-kHz Oscillator Range
- Separate Oscillator Sync Terminal
- Adjustable Deadtime Control
- Internal Soft-Start
- Pulse-by-Pulse Shutdown
- Input Undervoltage Lockout With Hysteresis
- Latching PWM to Prevent Multiple Pulses
- Dual Source/Sink Output Drivers

DESCRIPTION

The UC1525A/1527A series of pulse width modulator integrated circuits are designed to offer improved performance and lowered external parts count when used in designing all types of switching power supplies. The on-chip +5.1-V reference is trimmed to 1% and the input common-mode range of the error amplifier includes the reference voltage, eliminating external resistors. A sync input to the oscillator allows multiple units to be slaved or a single unit to be synchronized to an external system clock. A single resistor between the C_T and the discharge terminals provides a wide range of dead-time adjustment. These devices also feature built-in soft-start circuitry with only an external timing capacitor required. A shutdown terminal controls both the soft-start circuitry and the output stages, providing instantaneous turn off through the PWM latch with pulsed shutdown, as well as soft-start recycle with longer shutdown commands.

BLOCK DIAGRAM

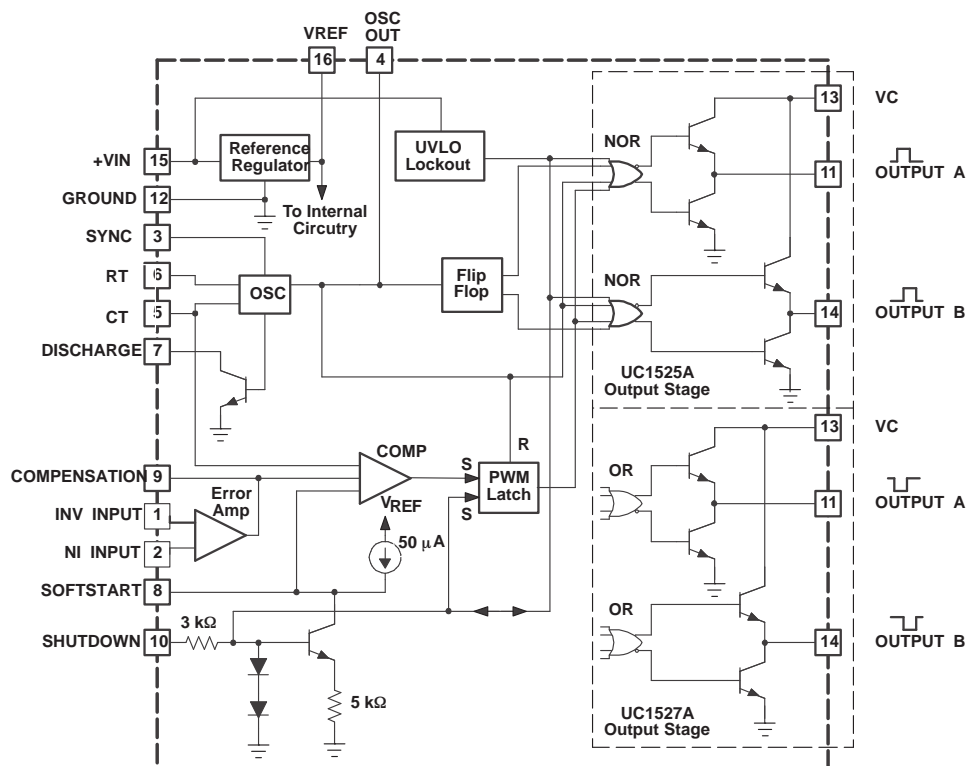

Please be aware that an important notice concerning availability, standard warranty, and use in critical applications of Texas Instruments semiconductor products and disclaimers thereto appears at the end of this data sheet.



These devices have limited built-in ESD protection. The leads should be shorted together or the device placed in conductive foam during storage or handling to prevent electrostatic damage to the MOS gates.

DESCRIPTION (continued)

These functions are also controlled by an undervoltage lockout which keeps the outputs off and the soft-start capacitor discharged for sub-normal input voltages. This lockout circuitry includes approximately 500 mV of hysteresis for jitter-free operation. Another feature of these PWM circuits is a latch following the comparator. Once a PWM pulse has been terminated for any reason, the outputs will remain off for the duration of the period. The latch is reset with each clock pulse. The output stages are totem-pole designs capable of sourcing or sinking in excess of 200 mA. The UC1525A output stage features NOR logic, giving a LOW output for an OFF state. The UC1527A utilizes OR logic which results in a HIGH output level when OFF.

ABSOLUTE MAXIMUM RATINGS⁽¹⁾

		UCx52xA	UNIT
+V _{IN}	Supply voltage	40	V
V _C	Collector supply voltage	40	
	Logic inputs	−0.3 to +5.5	
	Analog inputs	−0.3 to +V _{IN}	
	Output current, source or sink	500	mA
	Reference output current	50	
	Oscillator charging current	5	
	Power dissipation at T _A = +25°C ⁽²⁾	1000	mW
	Power dissipation at T _C = +25°C ⁽²⁾	2000	
	Operating junction temperature	−55 to 150	°C
	Storage temperature range	−65 to 150	
	Lead temperature (soldering, 10 seconds)	300	

(1) Values beyond which damage may occur.

(2) See Thermal Characteristics table.

RECOMMENDED OPERATING CONDITIONS⁽¹⁾

		MIN	MAX	UNIT	
+V _{IN}	Input voltage	8	35	V	
V _C	Collector supply voltage	4.5	35		
	Sink/source load current (steady state)	0	100	mA	
	Sink/source load current (peak)	0	400		
	Reference load current	0	20		
	Oscillator frequency range	100	400	Hz	
	Oscillator timing resistor	2	150	kΩ	
	Oscillator timing capacitorm	0.001	0.01	μF	
	Dead time resistor range	0	500	Ω	
	Operating ambient temperature range	UC1525A, UC1527A	−55	125	°C
		UC2525A, UC2527A	−25	85	
		UC3525A, UC3527A	0	70	

(1) Range over which the device is functional and parameter limits are assured.

THERMAL CHARACTERISTICS

over operating free-air temperature range (unless otherwise noted)

PACKAGE	θ_{JA}	θ_{JC}
J-16	80-120	28
N-16	90	45
DW-16	45-90	25
PLCC-20	43-75	34
LCC-20	70-80	20

CONNECTION DIAGRAMS

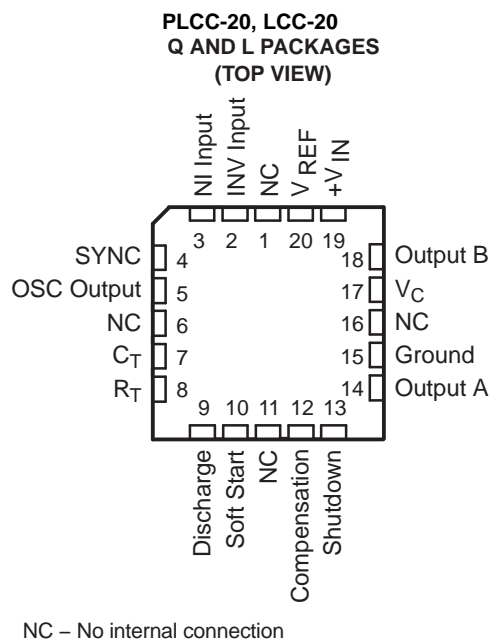
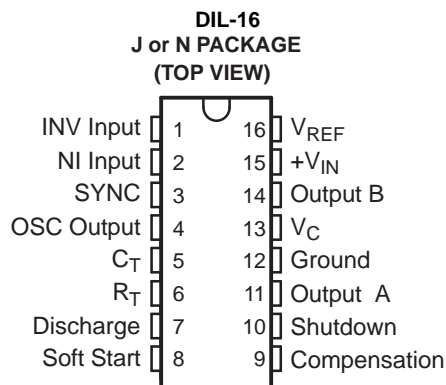

ELECTRICAL CHARACTERISTICS

+V_{IN} = 20 V, and over operating temperature, unless otherwise specified, T_A = T_J

PARAMETER	TEST CONDITIONS	MIN	TYP	MAX	UNIT	
REFERENCE						
Output voltage	T _J = 25°C	UC152xA, UC252xA	5.05	5.10	5.15	V
		UC352xA	5.0	5.1	5.2	
Line regulation	V _{IN} = 8 V to 35 V		10	20	mV	
Load regulation	I _L = 0 mA to 20 mA		20	50		
Temperature stability ⁽¹⁾	Over operating range		20	50		
Total output variation ⁽¹⁾	Line, load, and temperature	UC152xA, UC252xA	5.0		5.2	V
		UC352xA	4.95		5.25	
Shorter circuit current	V _{REF} = 0, T _J = 25°C		80	100	mA	
Output noise Voltage ⁽¹⁾	10 Hz ≤ 10 kHz, T _J = 25°C		40	200	μVrms	
Long term stability ⁽¹⁾	T _J = 125°C		20	50	mV	
OSCILLATOR SECTION⁽²⁾						
Initial accuracy ^{(1) (2)}	T _J = 25°C		2%	6%		
Voltage stability ^{(1) (2)}	V _{IN} = 8 V to 35 V	UC152xA, UC252xA	0.3%	1%		
		UC352xA	1%	2%		
Temperature stability ⁽¹⁾	Over operating range		3%	6%		
Minimum frequency	R _T = 200 kΩ, C _T = 0.1 μF			120	Hz	
Maximum frequency	R _T = 2 kΩ, C _T = 470 pF	400			kHz	
Current mirror	I _{RT} = 2 mA	1.7	2.0	2.2	mA	
Clock amplitude ^{(1) (2)}		3.0	3.5		V	
Clock width ^{(1) (2)}	T _J = 25°C	0.3	0.5	1.0	μs	
Synchronization threshold ^{(1) (2)}		1.2	2.0	2.8	V	
Sync input current	Sync voltage = 3.5 V		1.0	2.5	mA	
ERROR AMPLIFIER SECTION (V_{CM} = 5.1 V)						
Input offset voltage		UC152xA, UC252xA	0.5	5	mV	
		UC352xA	2	10		
Input bias current			1	10	μA	
Input offset current				1		
DC open loop gain	R _L ≥ 10 MΩ	60	75		dB	
Gain-bandwidth product ⁽¹⁾	A _V = 0 dB, T _J = 25°C	1	2		MHz	
DC transconductanc ^{(1) (3)}	T _J = 25°C, 30 kΩ ≤ R _L ≤ 1 MΩ	1.1	1.5		mS	
Low-level output voltage			0.2	0.5	V	
High-level output voltage		3.8	5.6			
Common mode rejection	V _{CM} = 1.5 V to 5.2 V	60	75		dB	
Supply voltage rejection	V _{IN} = 8 V to 35 V	50	60			

(1) These parameters, although ensured over the recommended operating conditions, are not 100% tested in production.

(2) Tested at f_{OSC} = 40 kHz (R_T = 3.6 kΩ, C_T = 0.01 μF, R_D = 0. Approximate oscillator frequency is defined by:

$$f = \frac{1}{C_T(0.7R_T + 3R_D)}$$

(3) DC transconductance (g_M) relates to DC open-loop voltage gain (A_V) according to the following equation: A_V = g_MR_L where R_L is the resistance from pin 9 to ground. The minimum g_M specification is used to calculate minimum A_V when the error amplifier output is loaded.

ELECTRICAL CHARACTERISTICS (continued)

+V_{IN} = 20 V, and over operating temperature, unless otherwise specified, T_A = T_J

PARAMETER	TEST CONDITIONS	MIN	TYP	MAX	UNIT
PWM COMPARATOR					
Minimum duty-cycle				0%	
Maximum duty-cycle		45%	49%		
Input threshold ⁽⁴⁾	Zero duty-cycle	0.7	0.9		V
	Maximum duty-cycle		3.3	3.6	
Input bias current ⁽⁴⁾			0.05	1.0	μA
SHUTDOWN					
Soft-start current	V _{SD} = 0 V, V _{SS} = 0 V	25	50	80	μA
Soft-start low level	V _{SD} = 2.5 V		0.4	0.7	V
Shutdown threshold	To outputs, V _{SS} = 5.1 V, T _J = 25°C	0.6	0.8	1.0	
Shutdown input current	V _{SD} = 2.5 V		0.4	1.0	mA
Shutdown Delay ⁽⁵⁾	V _{SD} = 2.5 V, T _J = 25°C		0.2	0.5	μs
OUTPUT DRIVERS (each output) (V_C = 20 V)					
Low-level output voltage	I _{SINK} = 20 mA		0.2	0.4	V
	I _{SINK} = 100 mA		1.0	2.0	
High-level output voltage	I _{SOURCE} = 20 mA	18	19		
	I _{SOURCE} = 100 mA	17	18		
Undervoltage lockout	V _{COMP} and V _{SS} = High	6	7	8	
V _C OFF Current ⁽⁶⁾	V _C = 35 V			200	μA
Rise Time ⁽⁵⁾	C _L = 1 nF, T _J = 25°C		100	600	ns
Fall Time ⁽⁵⁾	C _L = 1 nF, T _J = 25°C		50	300	
TOTAL STANDBY CURRENT					
Supply Current	V _{IN} = 35 V		14	20	mA

(4) Tested at f_{OSC} = 40 kHz (R_T = 3.6 kΩ, C_T = 0.01 μF, R_D = 0 Ω).

(5) These parameters, although ensured over the recommended operating conditions, are not 100% tested in production.

(6) Collector off-state quiescent current measured at pin 13 with outputs low for UC1525A and high for UC1527A.

UC1525A Error Amplifier

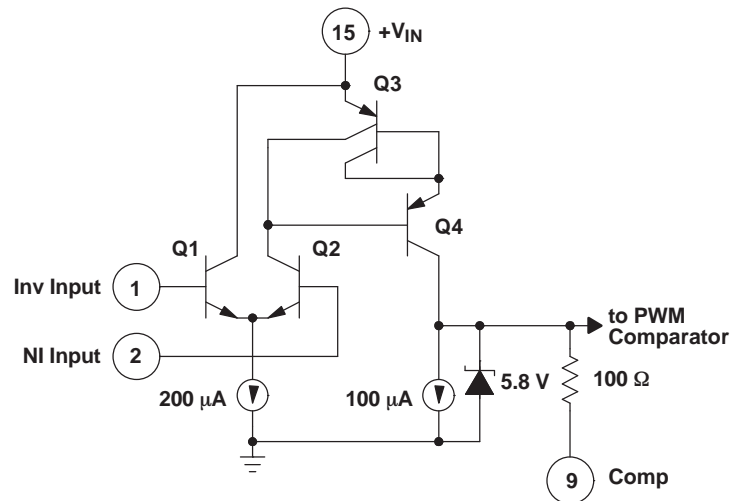

PRINCIPLES OF OPERATION AND TYPICAL CHARACTERISTICS

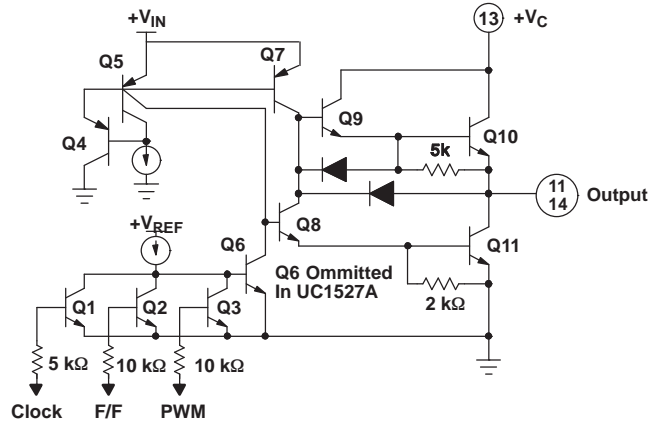

Figure 1. UC1525A Output Circuit (1/2 circuit shown)

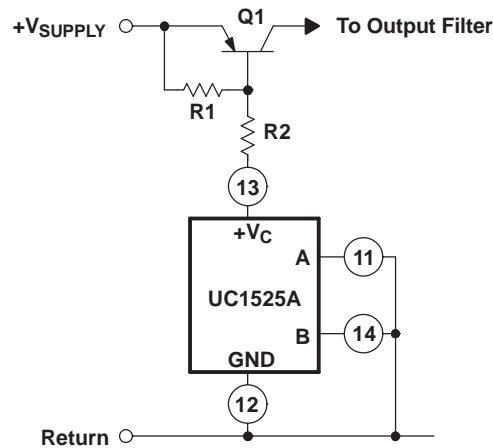

Figure 2. Grounded Driver Outputs For Single-Ended Supplies

For single-ended supplies, the driver outputs are grounded. The V_C terminal is switched to ground by the totem-pole source transistors on alternate oscillator cycles.

PRINCIPLES OF OPERATION AND TYPICAL CHARACTERISTICS (continued)

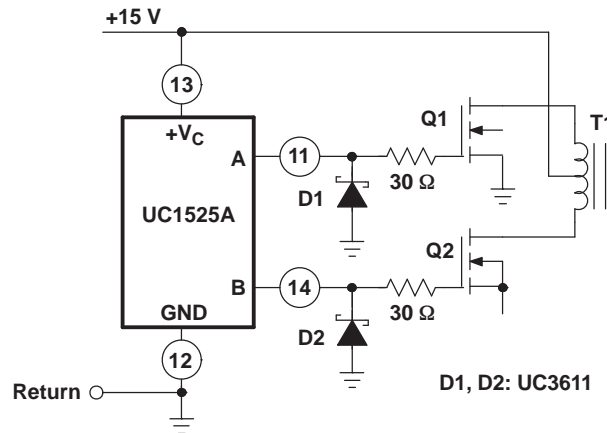

Figure 3. Output Drivers With Low Source Impedance

The low source impedance of the output drivers provides rapid charging of power FET input capacitance while minimizing external components.

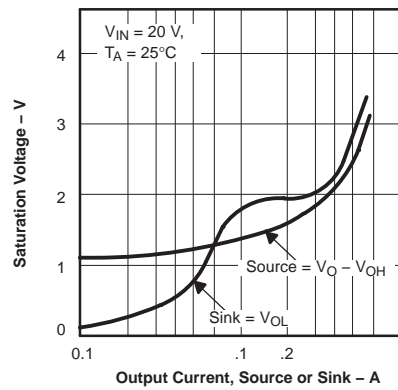

Figure 4. UC1525A Output Saturation Characteristics.

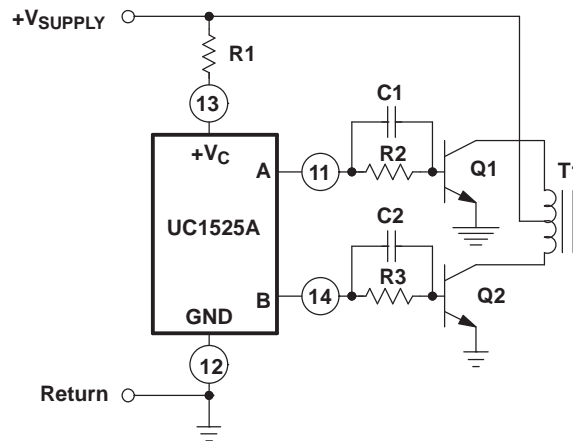

Figure 5. Conventional Push-Pull Bipolar Design

In conventional push-pull bipolar designs, forward base drive is controlled by R1–R3. Rapid turn-off times for the power devices are achieved with speed-up capacitors C1 and C2.

PRINCIPLES OF OPERATION AND TYPICAL CHARACTERISTICS (continued)

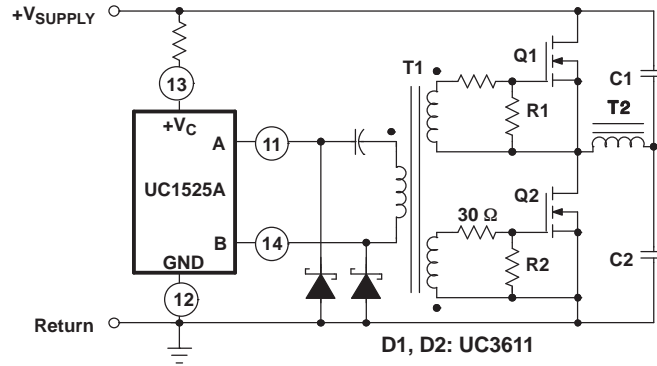

Figure 6. Low Power Transformers

Low power transformers can be driven by the UC1525A. Automatic reset occurs during dead time, when both ends of the primary winding are switched to ground.

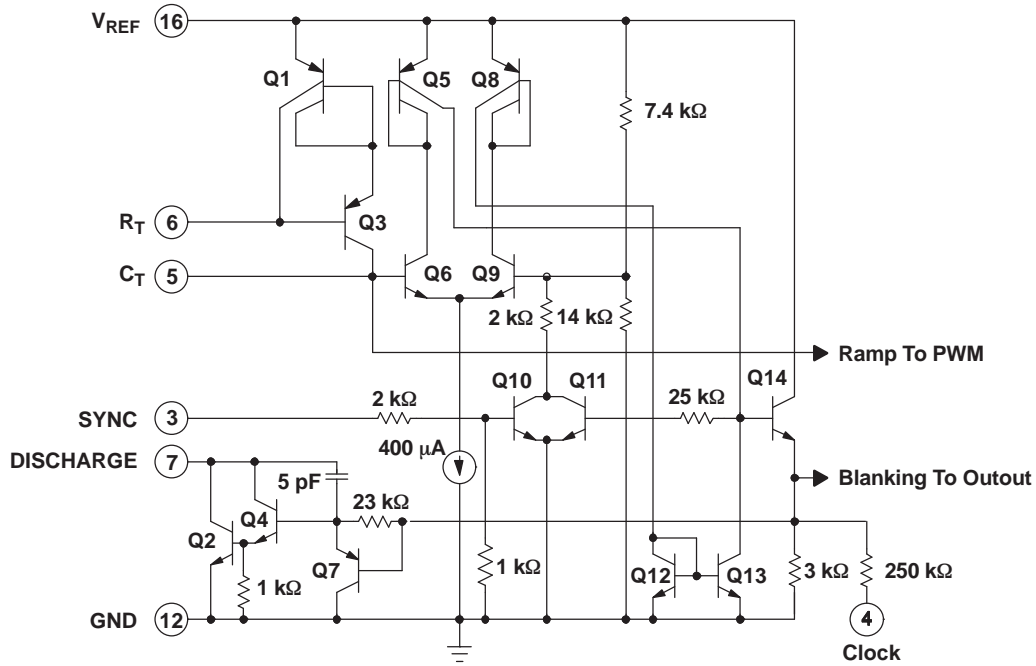

Figure 7. UC1525A Oscillator Schematic

PRINCIPLES OF OPERATION AND TYPICAL CHARACTERISTICS (continued)

Shutdown Options (See Block Diagram)

Since both the compensation and soft-start terminals (Pins 9 and 8) have current source pull-ups, either can readily accept a pull-down signal which only has to sink a maximum of 100 A to turn off the outputs. This is subject to the added requirement of discharging whatever external capacitance may be attached to these pins.

An alternate approach is the use of the shutdown circuitry of Pin 10 which has been improved to enhance the available shutdown options. Activating this circuit by applying a positive signal on Pin 10 performs two functions; the PWM latch is immediately set providing the fastest turn-off signal to the outputs; and a 150-A current sink begins to discharge the external soft-start capacitor. If the shutdown command is short, the PWM signal is terminated without significant discharge of the soft-start capacitor, thus, allowing, for example, a convenient implementation of pulse-by-pulse current limiting. Holding Pin 10 high for a longer duration, however, will ultimately discharge this external capacitor, recycling slow turn-on upon release.

Pin 10 should not be left floating as noise pickup could conceivably interrupt normal operation. All transitions of the voltage on pin 10 should be within the time frame of one clock cycle and not repeated at a frequency higher than 10 clock cycles.

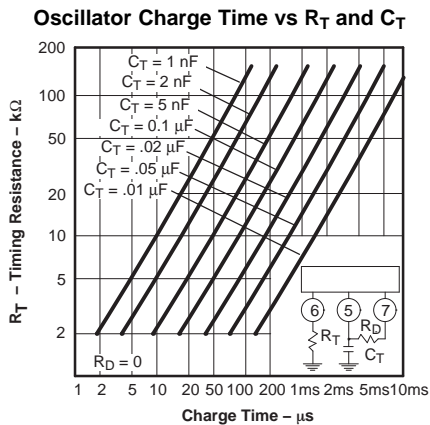

Figure 8.

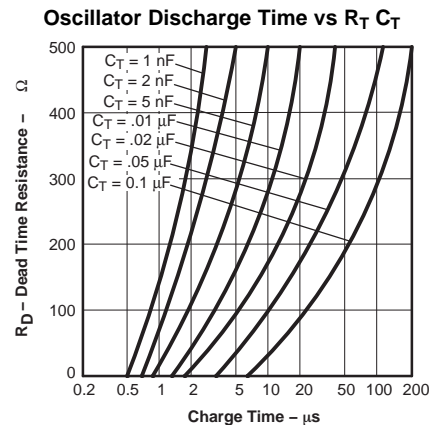

Figure 9.

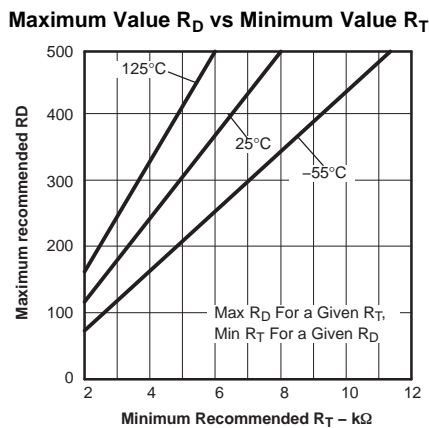

Figure 10.

Error Amplifier Voltage Gain and Phase vs Frequency

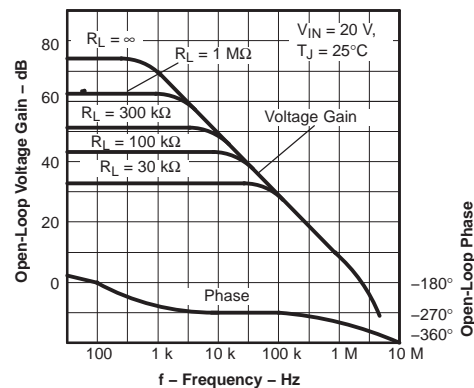

Figure 11.

PRINCIPLES OF OPERATION AND TYPICAL CHARACTERISTICS (continued)

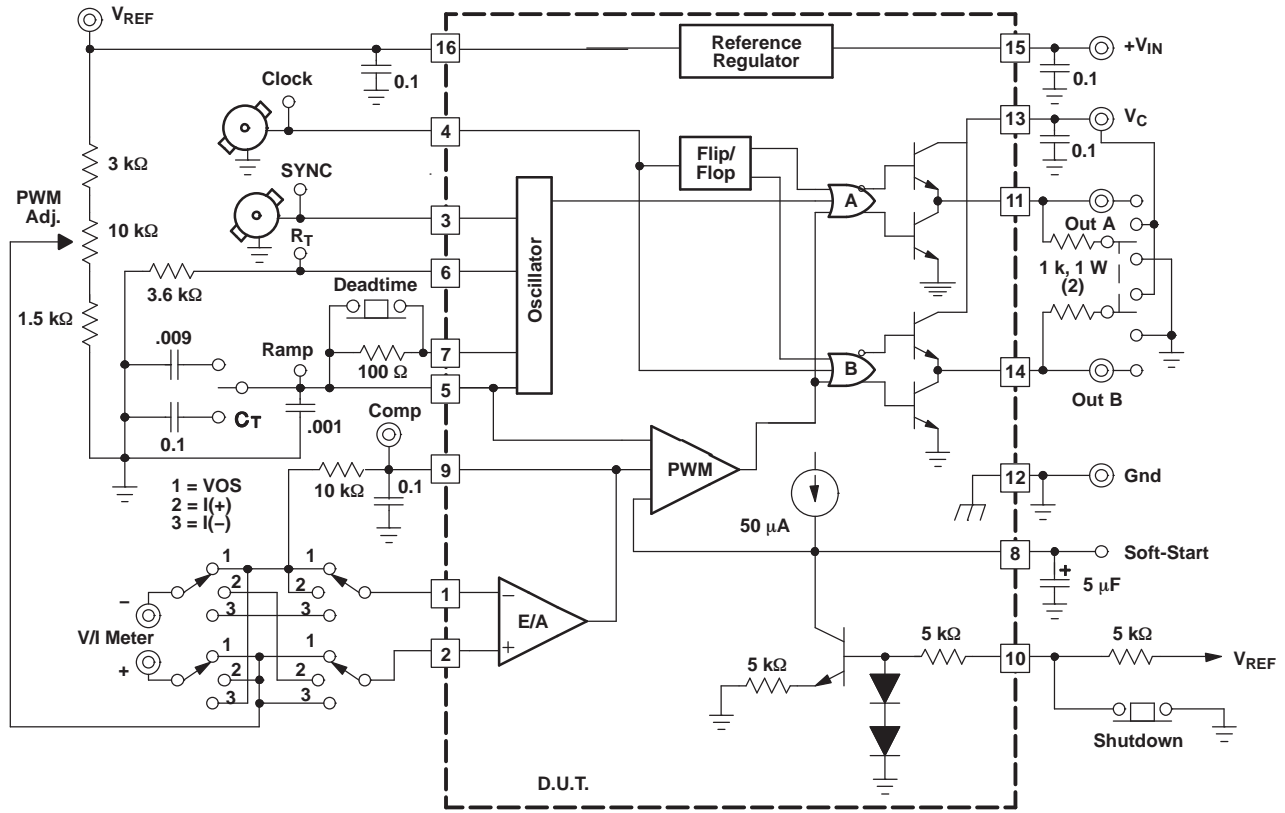

Figure 12. Lab Test Fixture

PACKAGING INFORMATION

Orderable Device	Status (1)	Package Type	Package Drawing	Pins	Package Qty	Eco Plan (2)	Lead/Ball Finish (6)	MSL Peak Temp (3)	Op Temp (°C)	Device Marking (4/5)	Samples
5962-89511012A	OBSOLETE	LCCC	FK	20		TBD	Call TI	Call TI	-55 to 125	5962-89511012A	
5962-89511032A	ACTIVE	LCCC	FK	20	1	TBD	POST-PLATE	N / A for Pkg Type	-55 to 125	5962- 89511032A UC1525AL/ 883B	Samples
5962-8951103EA	ACTIVE	CDIP	J	16	1	TBD	A42	N / A for Pkg Type	-55 to 125	5962-8951103EA UC1525AJ/883B	Samples
5962-89511042A	OBSOLETE	LCCC	FK	20		TBD	Call TI	Call TI	-55 to 125	5962-89511042A UC1527AL/ 883B	
5962-8951104EA	ACTIVE	CDIP	J	16	1	TBD	A42	N / A for Pkg Type	-55 to 125	5962-8951104EA UC1527AJ/883B	Samples
UC1525AJ	ACTIVE	CDIP	J	16	25	TBD	A42	N / A for Pkg Type	-55 to 125	UC1525AJ	Samples
UC1525AJ883B	ACTIVE	CDIP	J	16	1	TBD	A42	N / A for Pkg Type	-55 to 125	5962-8951103EA UC1525AJ/883B	Samples
UC1525AL	ACTIVE	LCCC	FK	20	1	TBD	POST-PLATE	N / A for Pkg Type	-55 to 125	UC1525AL	Samples
UC1525AL883B	ACTIVE	LCCC	FK	20	1	TBD	POST-PLATE	N / A for Pkg Type	-55 to 125	5962- 89511032A UC1525AL/ 883B	Samples
UC1527AJ	ACTIVE	CDIP	J	16	1	TBD	A42	N / A for Pkg Type	-55 to 125	UC1527AJ	Samples
UC1527AJ883B	ACTIVE	CDIP	J	16	1	TBD	A42	N / A for Pkg Type	-55 to 125	5962-8951104EA UC1527AJ/883B	Samples
UC1527AL883B	OBSOLETE	LCCC	FK	20		TBD	Call TI	Call TI	-55 to 125	5962-89511042A UC1527AL/ 883B	
UC2525ADW	ACTIVE	SOIC	DW	16	40	Green (RoHS & no Sb/Br)	CU NIPDAU	Level-2-260C-1 YEAR	-25 to 85	UC2525ADW	Samples
UC2525ADWG4	ACTIVE	SOIC	DW	16	40	Green (RoHS & no Sb/Br)	CU NIPDAU	Level-2-260C-1 YEAR	-25 to 85	UC2525ADW	Samples
UC2525ADWTR	ACTIVE	SOIC	DW	16	2000	Green (RoHS & no Sb/Br)	CU NIPDAU	Level-2-260C-1 YEAR	-25 to 85	UC2525ADW	Samples

Orderable Device	Status (1)	Package Type	Package Drawing	Pins	Package Qty	Eco Plan (2)	Lead/Ball Finish (6)	MSL Peak Temp (3)	Op Temp (°C)	Device Marking (4/5)	Samples
UC2525AJ	ACTIVE	CDIP	J	16	1	TBD	A42	N / A for Pkg Type	-25 to 85	UC2525AJ	Samples
UC2525AN	ACTIVE	PDIP	N	16	25	Green (RoHS & no Sb/Br)	CU NIPDAU	N / A for Pkg Type	-25 to 85	UC2525AN	Samples
UC2525ANG4	ACTIVE	PDIP	N	16	25	Green (RoHS & no Sb/Br)	CU NIPDAU	N / A for Pkg Type	-25 to 85	UC2525AN	Samples
UC2525BDW	ACTIVE	SOIC	DW	16	40	Green (RoHS & no Sb/Br)	CU NIPDAU	Level-2-260C-1 YEAR	-25 to 85	UC2525BDW	Samples
UC2525BDWG4	ACTIVE	SOIC	DW	16	40	Green (RoHS & no Sb/Br)	CU NIPDAU	Level-2-260C-1 YEAR	-25 to 85	UC2525BDW	Samples
UC2525BN	ACTIVE	PDIP	N	16	25	Green (RoHS & no Sb/Br)	CU NIPDAU	N / A for Pkg Type	-25 to 85	UC2525BN	Samples
UC2527AN	ACTIVE	PDIP	N	16	25	Green (RoHS & no Sb/Br)	CU NIPDAU	N / A for Pkg Type	-40 to 85	UC2527AN	Samples
UC2527ANG4	ACTIVE	PDIP	N	16	25	Green (RoHS & no Sb/Br)	CU NIPDAU	N / A for Pkg Type	-40 to 85	UC2527AN	Samples
UC3525ADW	ACTIVE	SOIC	DW	16	40	Green (RoHS & no Sb/Br)	CU NIPDAU	Level-2-260C-1 YEAR	0 to 70	UC3525ADW	Samples
UC3525ADWG4	ACTIVE	SOIC	DW	16	40	Green (RoHS & no Sb/Br)	CU NIPDAU	Level-2-260C-1 YEAR	0 to 70	UC3525ADW	Samples
UC3525ADWTR	ACTIVE	SOIC	DW	16	2000	Green (RoHS & no Sb/Br)	CU NIPDAU	Level-2-260C-1 YEAR	0 to 70	UC3525ADW	Samples
UC3525ADWTRG4	ACTIVE	SOIC	DW	16	2000	Green (RoHS & no Sb/Br)	CU NIPDAU	Level-2-260C-1 YEAR	0 to 70	UC3525ADW	Samples
UC3525AJ	ACTIVE	CDIP	J	16	1	TBD	A42	N / A for Pkg Type	0 to 70	UC3525AJ	Samples
UC3525AN	ACTIVE	PDIP	N	16	25	Green (RoHS & no Sb/Br)	CU NIPDAU	N / A for Pkg Type	0 to 70	UC3525AN	Samples
UC3525ANG4	ACTIVE	PDIP	N	16	25	Green (RoHS & no Sb/Br)	CU NIPDAU	N / A for Pkg Type	0 to 70	UC3525AN	Samples
UC3525AQ	ACTIVE	PLCC	FN	20	46	Green (RoHS & no Sb/Br)	CU SN	Level-2-260C-1 YEAR	0 to 70	UC3525AQ	Samples
UC3525AQQ3	ACTIVE	PLCC	FN	20	46	Green (RoHS & no Sb/Br)	CU SN	Level-2-260C-1 YEAR	0 to 70	UC3525AQ	Samples
UC3527AJ	OBSOLETE	CDIP	J	16		TBD	Call TI	Call TI	0 to 70	UC3527AJ	
UC3527AN	ACTIVE	PDIP	N	16	25	Green (RoHS & no Sb/Br)	CU NIPDAU	N / A for Pkg Type	0 to 70	UC3527AN	Samples

Orderable Device	Status (1)	Package Type	Package Drawing	Pins	Package Qty	Eco Plan (2)	Lead/Ball Finish (6)	MSL Peak Temp (3)	Op Temp (°C)	Device Marking (4/5)	Samples
UC3527ANG4	ACTIVE	PDIP	N	16	25	Green (RoHS & no Sb/Br)	CU NIPDAU	N / A for Pkg Type	0 to 70	UC3527AN	Samples

(1) The marketing status values are defined as follows:

ACTIVE: Product device recommended for new designs.

LIFEBUY: TI has announced that the device will be discontinued, and a lifetime-buy period is in effect.

NRND: Not recommended for new designs. Device is in production to support existing customers, but TI does not recommend using this part in a new design.

PREVIEW: Device has been announced but is not in production. Samples may or may not be available.

OBSOLETE: TI has discontinued the production of the device.

(2) Eco Plan - The planned eco-friendly classification: Pb-Free (RoHS), Pb-Free (RoHS Exempt), or Green (RoHS & no Sb/Br) - please check <http://www.ti.com/productcontent> for the latest availability information and additional product content details.

TBD: The Pb-Free/Green conversion plan has not been defined.

Pb-Free (RoHS): TI's terms "Lead-Free" or "Pb-Free" mean semiconductor products that are compatible with the current RoHS requirements for all 6 substances, including the requirement that lead not exceed 0.1% by weight in homogeneous materials. Where designed to be soldered at high temperatures, TI Pb-Free products are suitable for use in specified lead-free processes.

Pb-Free (RoHS Exempt): This component has a RoHS exemption for either 1) lead-based flip-chip solder bumps used between the die and package, or 2) lead-based die adhesive used between the die and leadframe. The component is otherwise considered Pb-Free (RoHS compatible) as defined above.

Green (RoHS & no Sb/Br): TI defines "Green" to mean Pb-Free (RoHS compatible), and free of Bromine (Br) and Antimony (Sb) based flame retardants (Br or Sb do not exceed 0.1% by weight in homogeneous material)

(3) MSL, Peak Temp. - The Moisture Sensitivity Level rating according to the JEDEC industry standard classifications, and peak solder temperature.

(4) There may be additional marking, which relates to the logo, the lot trace code information, or the environmental category on the device.

(5) Multiple Device Markings will be inside parentheses. Only one Device Marking contained in parentheses and separated by a "~" will appear on a device. If a line is indented then it is a continuation of the previous line and the two combined represent the entire Device Marking for that device.

(6) Lead/Ball Finish - Orderable Devices may have multiple material finish options. Finish options are separated by a vertical ruled line. Lead/Ball Finish values may wrap to two lines if the finish value exceeds the maximum column width.

Important Information and Disclaimer: The information provided on this page represents TI's knowledge and belief as of the date that it is provided. TI bases its knowledge and belief on information provided by third parties, and makes no representation or warranty as to the accuracy of such information. Efforts are underway to better integrate information from third parties. TI has taken and continues to take reasonable steps to provide representative and accurate information but may not have conducted destructive testing or chemical analysis on incoming materials and chemicals. TI and TI suppliers consider certain information to be proprietary, and thus CAS numbers and other limited information may not be available for release.

In no event shall TI's liability arising out of such information exceed the total purchase price of the TI part(s) at issue in this document sold by TI to Customer on an annual basis.

OTHER QUALIFIED VERSIONS OF UC1525A, UC1527A, UC2525A, UC2525AM, UC3525A, UC3525AM, UC3527A, UC3527AM :

- Catalog: [UC3525A](#), [UC3527A](#), [UC2525A](#), [UC3525AM](#), [UC3525A](#), [UC3527AM](#), [UC3527A](#)
- Military: [UC2525AM](#), [UC1525A](#), [UC1525A](#), [UC1527A](#), [UC1527A](#)

NOTE: Qualified Version Definitions:

- Catalog - TI's standard catalog product
- Military - QML certified for Military and Defense Applications

TAPE AND REEL INFORMATION

QUADRANT ASSIGNMENTS FOR PIN 1 ORIENTATION IN TAPE

*All dimensions are nominal

Device	Package Type	Package Drawing	Pins	SPQ	Reel Diameter (mm)	Reel Width W1 (mm)	A0 (mm)	B0 (mm)	K0 (mm)	P1 (mm)	W (mm)	Pin1 Quadrant
UC2525ADWTR	SOIC	DW	16	2000	330.0	16.4	10.75	10.7	2.7	12.0	16.0	Q1

TAPE AND REEL BOX DIMENSIONS

*All dimensions are nominal

Device	Package Type	Package Drawing	Pins	SPQ	Length (mm)	Width (mm)	Height (mm)
UC2525ADWTR	SOIC	DW	16	2000	367.0	367.0	38.0

IMPORTANT NOTICE

Texas Instruments Incorporated and its subsidiaries (TI) reserve the right to make corrections, enhancements, improvements and other changes to its semiconductor products and services per JESD46, latest issue, and to discontinue any product or service per JESD48, latest issue. Buyers should obtain the latest relevant information before placing orders and should verify that such information is current and complete. All semiconductor products (also referred to herein as "components") are sold subject to TI's terms and conditions of sale supplied at the time of order acknowledgment.

TI warrants performance of its components to the specifications applicable at the time of sale, in accordance with the warranty in TI's terms and conditions of sale of semiconductor products. Testing and other quality control techniques are used to the extent TI deems necessary to support this warranty. Except where mandated by applicable law, testing of all parameters of each component is not necessarily performed.

TI assumes no liability for applications assistance or the design of Buyers' products. Buyers are responsible for their products and applications using TI components. To minimize the risks associated with Buyers' products and applications, Buyers should provide adequate design and operating safeguards.

TI does not warrant or represent that any license, either express or implied, is granted under any patent right, copyright, mask work right, or other intellectual property right relating to any combination, machine, or process in which TI components or services are used. Information published by TI regarding third-party products or services does not constitute a license to use such products or services or a warranty or endorsement thereof. Use of such information may require a license from a third party under the patents or other intellectual property of the third party, or a license from TI under the patents or other intellectual property of TI.

Reproduction of significant portions of TI information in TI data books or data sheets is permissible only if reproduction is without alteration and is accompanied by all associated warranties, conditions, limitations, and notices. TI is not responsible or liable for such altered documentation. Information of third parties may be subject to additional restrictions.

Resale of TI components or services with statements different from or beyond the parameters stated by TI for that component or service voids all express and any implied warranties for the associated TI component or service and is an unfair and deceptive business practice. TI is not responsible or liable for any such statements.

Buyer acknowledges and agrees that it is solely responsible for compliance with all legal, regulatory and safety-related requirements concerning its products, and any use of TI components in its applications, notwithstanding any applications-related information or support that may be provided by TI. Buyer represents and agrees that it has all the necessary expertise to create and implement safeguards which anticipate dangerous consequences of failures, monitor failures and their consequences, lessen the likelihood of failures that might cause harm and take appropriate remedial actions. Buyer will fully indemnify TI and its representatives against any damages arising out of the use of any TI components in safety-critical applications.

In some cases, TI components may be promoted specifically to facilitate safety-related applications. With such components, TI's goal is to help enable customers to design and create their own end-product solutions that meet applicable functional safety standards and requirements. Nonetheless, such components are subject to these terms.

No TI components are authorized for use in FDA Class III (or similar life-critical medical equipment) unless authorized officers of the parties have executed a special agreement specifically governing such use.

Only those TI components which TI has specifically designated as military grade or "enhanced plastic" are designed and intended for use in military/aerospace applications or environments. Buyer acknowledges and agrees that any military or aerospace use of TI components which have **not** been so designated is solely at the Buyer's risk, and that Buyer is solely responsible for compliance with all legal and regulatory requirements in connection with such use.

TI has specifically designated certain components as meeting ISO/TS16949 requirements, mainly for automotive use. In any case of use of non-designated products, TI will not be responsible for any failure to meet ISO/TS16949.

Products

Audio	www.ti.com/audio
Amplifiers	amplifier.ti.com
Data Converters	dataconverter.ti.com
DLP® Products	www.dlp.com
DSP	dsp.ti.com
Clocks and Timers	www.ti.com/clocks
Interface	interface.ti.com
Logic	logic.ti.com
Power Mgmt	power.ti.com
Microcontrollers	microcontroller.ti.com
RFID	www.ti-rfid.com
OMAP Applications Processors	www.ti.com/omap
Wireless Connectivity	www.ti.com/wirelessconnectivity

Applications

Automotive and Transportation	www.ti.com/automotive
Communications and Telecom	www.ti.com/communications
Computers and Peripherals	www.ti.com/computers
Consumer Electronics	www.ti.com/consumer-apps
Energy and Lighting	www.ti.com/energy
Industrial	www.ti.com/industrial
Medical	www.ti.com/medical
Security	www.ti.com/security
Space, Avionics and Defense	www.ti.com/space-avionics-defense
Video and Imaging	www.ti.com/video

TI E2E Community

e2e.ti.com