

## LLC Half-Bridge Controller For Multi-String LED Lighting

 Check for Samples: [UCC25710](#)

### FEATURES

- Closed Loop LED String Current Control
- PWM Dimming Input
- Adjustable  $F_{MIN}$  (3% accuracy), and  $F_{MAX}$  (7.5% accuracy)
- LLC and Series LED Switch Control for Dimming
- Programmable Dimming LLC ON/OFF Ramp for Elimination of Audible Noise
- Closed Loop Current Control at Low Dimming Duty Cycles
- Programmable Soft Start
- Accurate  $V_{REF}$  for Tight Output Regulation
- Over-Voltage, Under-Voltage and Input Over-Current Protection with Auto-Restart Response
- Second Over-Current Threshold with Latch-Off Response
- 400-mA/800-mA Gate Drive Current
- Low Start-Up and Operating Currents
- Lead (Pb)-Free, 20-pin, SOIC package

### APPLICATIONS

- LED Backlight for LCD TV and Monitors
- LED General Lighting

### DESCRIPTION

The UCC25710 is an LLC half-bridge controller for accurate control of multi-string LED backlight applications. It is optimized for multi-transformer, multi-string LED architectures. Superior LED current matching in multiple strings can be achieved with this controller and architecture. Compared to existing LED backlight solutions, the multi-transformer architecture provides the highest overall efficiency from AC input to LED load.

The LLC controller function includes a Voltage Controlled Oscillator (VCO) with programmable  $F_{MIN}$  and  $F_{MAX}$ , half-bridge gate drivers with a fixed dead time of 500 ns and a GM current amplifier. The LLC power delivery is modulated by the controller's VCO frequency. The VCO has an accurate and programmable frequency range. At very low power levels the VCO frequency goes from  $F_{MAX}$  to zero to maximize efficiency at low LED currents.

### Simplified Application Diagram

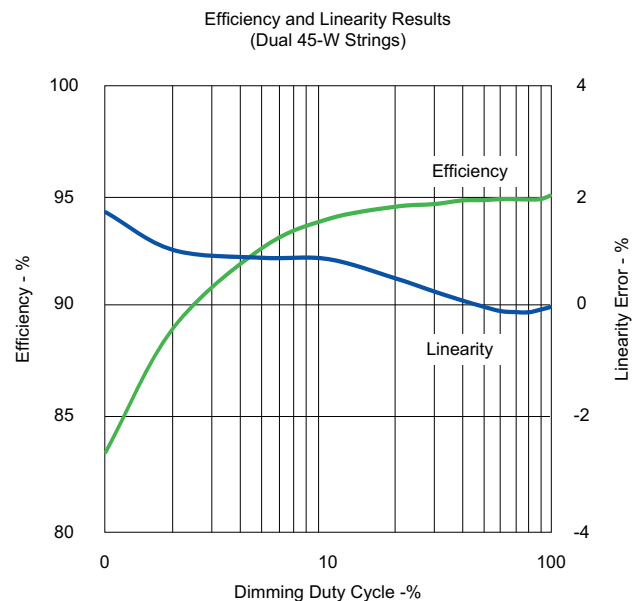
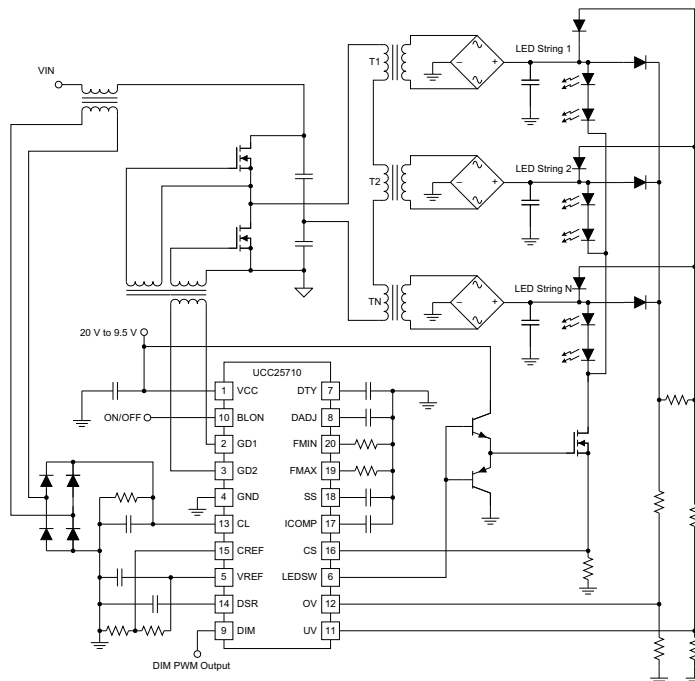

Please be aware that an important notice concerning availability, standard warranty, and use in critical applications of Texas Instruments semiconductor products and disclaimers thereto appears at the end of this data sheet.

## DESCRIPTION (CONT.)

The LED current loop reference is set by a divider off the  $V_{REF}$  5-V output. The reference can be varied over a 0.5 V to 2.6 V range, allowing analog dimming to be combined with PWM dimming.

PWM dimming is used to control an external LED series switch and also to gate on and off the LLC power stage. The LEDSW output along with a simple drive circuit is used to switch on and off the LED string current. This output responds directly to the input signal at the dimming input, DIM. The LLC is also ramped on and off with the dimming PWM input. The on and off LLC dimming edges are ramped at programmable slew rates to control audible noise. The dimming function includes duty-cycle compensation to allow optimization of overall efficiency and dimming linearity over a maximum range.

The control voltage to the VCO is set by ICOMP (current amplifier output) during LED on-times. During start-up the soft-start pin, SS, will control the VCO response until it exceeds ICOMP. During dimming the rise and fall rates of the VCO input are controlled by the voltage at the dimming slew rate, DSR, pin while the pedestal of VCO control level will continue to be controlled by ICOMP. The current amplifier output is connected to ICOMP only during the commanded dimming LED on-time. The LLC on-time is extended beyond the LED current on-time at low dimming duty-cycles to maintain closed loop control of the LED current.

Protection thresholds for LED string over-voltage and under-voltage conditions are set with external resistive dividers and accurate internal thresholds. Input current to the converter is monitored with both a re-start and latch-off response depending on the over-current level. The controller also includes thermal shutdown protection.

The auto re-start response to any fault includes a 10-ms reset period followed by a soft-start. In the case of a severe input over-current, restart will be disabled until the input supply is cycled through its UVLO threshold.



This integrated circuit can be damaged by ESD. Texas Instruments recommends that all integrated circuits be handled with appropriate precautions. Failure to observe proper handling and installation procedures can cause damage.

ESD damage can range from subtle performance degradation to complete device failure. Precision integrated circuits may be more susceptible to damage because very small parametric changes could cause the device not to meet its published specifications.

## ORDERING INFORMATION

PART NUMBER	PACKAGED DEVICES <sup>(1)</sup>	OPERATING TEMPERATURE RANGE, $T_A$
UCC25710DW	SOIC 20-Pin (DW)	-40°C to 125°C

(1) DW (SOIC-20) package is available taped and reeled. Add R suffix to device type (e.g. UCC25710R) to order quantities of 2,500 devices per reel.

## ABSOLUTE MAXIMUM RATINGS<sup>(1)</sup>

over operating free-air temperature range (unless otherwise noted)

		MIN	MAX	UNIT
Supply voltage	$V_{CC}$		20	V
LEDSW Output Current	$I_{LEDSW}$		+/- 2	mA
VREF Output Current	$I_{VREF}$		-20	
Gate drive RMS current continuous GD1, GD2	$I_{GD1}, I_{DG2}$		25	V
Gate drive voltage, GD1 GD2	$V_{GD1}, V_{GD2}$	-0.5	$V_{CC} + 0.5$	
Voltage range	CS, CL, OV, UV, BLON, DIM, CREF	-0.5	7	°C
Operating junction temperature range, $T_J$		-55	150	
Storage temperature, $T_{STG}$		-65	150	
Lead temperature 1,6 mm (1/16 inch) from case for 10 seconds			260	
ESD - Human Body Model	HBM		2000	V
ESD - Charged Device Model	CDM		500	

(1) Stresses beyond those listed under “absolute maximum ratings” may cause permanent damage to the device. These are stress ratings only and functional operation of the device at these or any other conditions beyond those indicated under “recommended operating conditions” is not implied. Exposure to absolute-maximum-rated conditions for extended periods may affect device reliability. All voltages are with respect to GND. Currents are positive into, negative out of the specified terminal. These ratings apply over the operating ambient temperature ranges unless otherwise noted.

## THERMAL INFORMATION

THERMAL METRIC <sup>(1)</sup>		UCC25710		UNITS
		SOIC (DW)		
		20 PINS		
$\theta_{JA}$	Junction-to-ambient thermal resistance <sup>(2)</sup>	79		°C/W
$\theta_{JCTop}$	Junction-to-case (top) thermal resistance <sup>(3)</sup>	43		
$\theta_{JB}$	Junction-to-board thermal resistance <sup>(4)</sup>	44		
$\psi_{JT}$	Junction-to-top characterization parameter <sup>(5)</sup>	16		
$\psi_{JB}$	Junction-to-board characterization parameter <sup>(6)</sup>	44		

- (1) For more information about traditional and new thermal metrics, see the *IC Package Thermal Metrics* application report, [SPRA953](#).
- (2) The junction-to-ambient thermal resistance under natural convection is obtained in a simulation on a JEDEC-standard, high-K board, as specified in JESD51-7, in an environment described in JESD51-2a.
- (3) The junction-to-case (top) thermal resistance is obtained by simulating a cold plate test on the package top. No specific JEDEC-standard test exists, but a close description can be found in the ANSI SEMI standard G30-88.
- (4) The junction-to-board thermal resistance is obtained by simulating in an environment with a ring cold plate fixture to control the PCB temperature, as described in JESD51-8.
- (5) The junction-to-top characterization parameter,  $\psi_{JT}$ , estimates the junction temperature of a device in a real system and is extracted from the simulation data for obtaining  $\theta_{JA}$ , using a procedure described in JESD51-2a (sections 6 and 7).
- (6) The junction-to-board characterization parameter,  $\psi_{JB}$ , estimates the junction temperature of a device in a real system and is extracted from the simulation data for obtaining  $\theta_{JA}$ , using a procedure described in JESD51-2a (sections 6 and 7).

## RECOMMENDED OPERATING CONDITIONS

all voltages are with respect to GND; currents are positive into and negative out of the specified terminal.  $-40^{\circ}\text{C} < T_J = T_A < 125^{\circ}\text{C}$  (unless otherwise noted)

		MIN	TYP	MAX	UNIT
$V_{CC}$	Operating input voltage	11		18	V
$C_{VCC}$	VCC bypass capacitor	0.47		-	$\mu\text{F}$
	Operating junction temperature	-40		125	°C
	Switching frequency at gate drive outputs	25		350	kHz
$V_{CREF}$	Input voltage range (linear range)	0.6	1.65	2.7	V
$V_{CREF}$	Input voltage range (using internal clamps)	0		$V_{VREF}$	
$C_{VREF}$	VREF bypass capacitor	0.22	1.0	2.2	$\mu\text{F}$
$C_{SS}$	SS capacitor	10		250	nF
$C_{ICOMP}$	ICOMP capacitor	0.5		47	
$C_{DTY}$	DTY capacitor	0.22		6.8	$\mu\text{F}$
$C_{DSR}$	DSR capacitor	0		2500	pF

## ELECTRICAL CHARACTERISTICS

$T_A = -40^{\circ}\text{C}$  to  $125^{\circ}\text{C}$ ,  $T_A = T_J$ ,  $V_{VCC} = 12\text{ V}$ ,  $V_{BLON} = 3\text{ V}$ ,  $V_{UV} = 3\text{ V}$ ,  $V_{OV} = 2$ ,  $V_{CL} = 0\text{ V}$ ,  $R_{MIN} = 100\text{ k}\Omega$ ,  $R_{MAX} = 4.99\text{ k}\Omega$ , (unless otherwise noted)

PARAMETER	TEST CONDITIONS	MIN	TYP	MAX	UNITS
<b>Supply Input</b>					
$V_{VCCMAX}$	VCC operating voltage			18	V
$I_{OFF}$	Supply current, off	$V_{VCC} = 8\text{ V}$	160	250	$\mu\text{A}$
$I_{ON}$	Supply current, on	Switching frequency = $F_{MIN}$ (30 KHz)	1.4	2.1	mA
$I_{DISABLE}$	Supply current, disabled	$V_{VCC} = 12\text{ V}$ , $V_{BLON} = 0\text{ V}$	240	350	$\mu\text{A}$
$I_{LATCHOFF}$	Supply current, latched off	Fault latch set	600	900	
<b>Under-Voltage Lockout</b>					
$V_{VCCON}$	VCC turn-on threshold	$V_{VCC}$ low-to-high	8.6	9.3	10.1
$V_{VCCOFF}$	VCC turn-off threshold	$V_{VCC}$ high-to-low	8.3	9.0	9.6
$V_{VCCHYS}$	Hysteresis		0.20	0.35	0.50
<b>5-V Reference Output</b>					
$V_{VREF}$	5-V Reference	$I_{VREF} = 0$ to $10\text{ mA}$ , $T_J = 25^{\circ}\text{C}$	4.95	5.00	5.05
$V_{VREF}$	5-V Reference	$I_{VREF} = 0$ to $10\text{ mA}$ , $T_J = -40^{\circ}\text{C}$ to $125^{\circ}\text{C}$	4.85	5.00	5.15
<b>Current Amplifier</b>					
$V_{ICOMPIS}$	Input offset voltage	$V_{CREF} = 1.65\text{ V}$ , $I_{COMP}$ tied to CS	-15		15
$I_{CS}$	Input bias current at CS input	$V_{CREF} = 1.65\text{ V}$ , $V_{CS} = 1.65\text{ V}$	-0.25		0.25
$I_{CR}$	Input bias current at CREF input	$V_{CREF} = 1.65\text{ V}$ , $V_{CS} = 1.65\text{ V}$	-0.25		0.25
$V_{ICOMP HI}$	ICOMP high	$V_{CS} = 0\text{ V}$ , $V_{CREF} = 1.65\text{ V}$ , $I_{ICOMP} = 50\text{ }\mu\text{A}$	4.6	4.85	
$V_{ICOMP LO}$	ICOMP low	$V_{CS} = 3\text{ V}$ , $V_{CREF} = 1.65\text{ V}$ , $I_{ICOMP} = -50\text{ }\mu\text{A}$		0.35	0.65
$G_{M_{ICOMP}}$	ICOMP transconductance	$I_{COMP}$ tied to $C_S$ , $I_{ICOMP} = -100\text{ }\mu\text{A}$ to $100\text{ }\mu\text{A}$	440	510	600
$I_{ICOMP SRC}$	Source current ICOMP	$V_{CS} = 0.65\text{ V}$ , $V_{CREF} = 1.65\text{ V}$ , $V_{ICOMP} = 2.5\text{ V}$	120	150	180
$I_{ICOMP SNK}$	Sink current ICOMP	$V_{CS} = 2.65\text{ V}$ , $V_{CREF} = 1.65\text{ V}$ , $V_{ICOMP} = 2.5\text{ V}$	195	245	295
$I_{ICOMP LK}$	LED off leakage current at ICOMP	$V_{DIM} = 0\text{ V}$ , $V_{ICOMP} = 2.5\text{ V}$ , $T_J = -40^{\circ}\text{C}$ to $85^{\circ}\text{C}$	-0.1		0.1
$V_{CREFC LO}$	CREF low Clamp	$V_{CREF} = 0\text{ V}$ , ICOMP tied to CS, regulating voltage at ICOMP	0.475	0.500	0.535
$V_{CREFC HI}$	CREF high Clamp	$V_{CREF} = 3\text{ V}$ , ICOMP tied to CS, regulating voltage at ICOMP	2.65	2.80	2.95
<b>Soft Start</b>					
$I_{SS}$	Soft-start charging current	$V_{SS} = 2.25\text{ V}$	2.0	2.5	3.0
$R_{SSDC}$	Soft-start discharge resistance	$V_{SS} = 1\text{ V}$		3.4	5.0
$V_{SS TH}$	Soft-start threshold	SS clamp released	3.95	4.15	4.40
$T_{RST DLY}$	Reset delay	From UVLO turn on to start of soft start	7	10	13
<b>Voltage Controlled Oscillator</b>					
$F_{MIN}$	$F_{MIN}$ GD1, GD2	$R_{MIN} = 100\text{ k}\Omega$ , $V_{ICOMP} = 5\text{ V}$	29.5	30.5	31.5
$F_{MAX}$	$F_{MAX}$ GD1, GD2	$R_{MIN} = 100\text{ k}\Omega$ , $R_{MAX} = 4.99\text{ k}\Omega$ , $V_{ICOMP} = 0.95\text{ V}$	275	300	320
$T_{DT}$	Dead time GD1, GD2	$R_{MIN} = 100\text{ k}\Omega$ , $V_{ICOMP} = 3\text{ V}$	400	500	600
$T_{MATCH}$	On-time mismatching	$R_{MIN} = 100\text{ k}\Omega$ , $V_{ICOMP} = 3\text{ V}$	-50		50
$V_{VCO TH LO}$	$V_{ICOMP}$ VCO Threshold Low	Disable GD1, GD2, $V_{ICOMP}$ high to low	0.80	0.90	0.95
$V_{VCO TH MAX}$	$V_{ICOMP}$ for $F_{MIN}$	Frequency reaches $F_{MIN}$	3.8	4.0	4.2

**ELECTRICAL CHARACTERISTICS (continued)**

$T_A = -40^{\circ}\text{C}$  to  $125^{\circ}\text{C}$ ,  $T_A = T_J$ ,  $V_{VCC} = 12\text{ V}$ ,  $V_{BLON} = 3\text{ V}$ ,  $V_{UV} = 3\text{ V}$ ,  $V_{OV} = 2\text{ V}$ ,  $V_{CL} = 0\text{ V}$ ,  $R_{MIN} = 100\text{ k}\Omega$ ,  $R_{MAX} = 4.99\text{ k}\Omega$ , (unless otherwise noted)

PARAMETER		TEST CONDITIONS	MIN	TYP	MAX	UNITS
<b>Gate Drivers</b>						
$V_{GDHI}$	GD1, GD2 $V_{OUT}$ high	$I_{GD1}, I_{GD2} = -20\text{ mA}$ , below VCC		1.8	3.0	V
$R_{GDHSRES}$	GD1, GD2 on-resistance high	$I_{GD1}, I_{GD2} = -20\text{ mA}$		14	30	$\Omega$
$V_{GDLO}$	GD1, GD2 $V_{OUT}$ low	$I_{GD1}, I_{GD2} = 20\text{ mA}$		0.08	0.20	V
$R_{GDLSRES}$	GD1, GD2 on-resistance low	$I_{GD1}, I_{GD2} = 20\text{ mA}$		4	10	$\Omega$
$T_{GDRISE}$	GD1, GD2 output rise time	$C_{GD} = 1\text{ nF}$ , 1 V to 9 V		25	35	ns
$T_{GDFALL}$	GD1, GD2 output fall time	$C_{GD} = 1\text{ nF}$ , 9 V to 1 V		20	30	
<b>Under-Voltage Protection</b>						
$V_{UVTH}$	Under-voltage threshold	High-to-low on UV input	2.27	2.40	2.53	V
$V_{UVHY}$	Under-voltage threshold hysteresis		190	240	300	mV
$I_{UV}$	UV input bias current	$V_{UV} = 2.7\text{ V}$	-0.25		0.25	$\mu\text{A}$
<b>Over-Voltage Protection</b>						
$V_{OVTH}$	Over-voltage threshold	Low-to-high on OV input	2.46	2.60	2.74	V
$V_{OVHY}$	Over-voltage threshold hysteresis		190	240	300	mV
$I_{OV}$	OV input bias current	$V_{OV} = 2.3\text{ V}$	-0.25		0.25	$\mu\text{A}$
<b>Current Limit Protection</b>						
$V_{CLTH}$	Current limit threshold	Low-to-high on CL input	0.90	0.95	1.00	V
$V_{CLHY}$	Current limit threshold hysteresis		375	475	525	mV
$V_{CLLTH}$	Current limit latching threshold	Low-to-high on CL input	1.75	1.90	2.05	V
$I_{CL}$	CL input bias current	$V_{CL} = 2.2\text{ V}$	-0.25		0.25	$\mu\text{A}$
<b>Thermal Shutdown</b>						
$t_{TSD}$	Junction temperature at thermal shutdown	Temperature rising	135	160	185	$^{\circ}\text{C}$
$t_{HYS}$	Thermal hysteresis			25	45	
<b>Backlight On Input</b>						
$R_{BLON}$	RBLON pull-down resistance	Pull down to GND	100	200	350	k $\Omega$
$V_{BLON}$	Enable threshold		0.8	1.2	1.6	V

**ELECTRICAL CHARACTERISTICS (continued)**

$T_A = -40^\circ\text{C}$  to  $125^\circ\text{C}$ ,  $T_A = T_J$ ,  $V_{VCC} = 12\text{ V}$ ,  $V_{BLON} = 3\text{ V}$ ,  $V_{UV} = 3\text{ V}$ ,  $V_{OV} = 2$ ,  $V_{CL} = 0\text{ V}$ ,  $R_{MIN} = 100\text{ k}\Omega$ ,  $R_{MAX} = 4.99\text{ k}\Omega$ , (unless otherwise noted)

PARAMETER		TEST CONDITIONS	MIN	TYP	MAX	UNITS
<b>PWM Dimming</b>						
$V_{DIM}$	Dimming input threshold		1.2	1.5	1.8	V
$R_{DIM}$	DIM pull-up resistance	Pull-up resistance to VREF, $V_{DIM} = 0\text{ V} - 4.5\text{ V}$	140	180	240	k $\Omega$
$V_{LEDSWHI}$	High level at LEDSW output	$I_{LEDSW} = -100\text{ }\mu\text{A}$ , below VCC, $V_{DIM} = 3\text{ V}$		0.4	1.0	V
$V_{LEDSWLO}$	Low level at LEDSW output	$I_{LEDSW} = 100\text{ }\mu\text{A}$ , $V_{DIM} = 0\text{ V}$		0.2	0.5	
$R_{LEDSWHI}$	High level output resistance	$I_{LEDSW} = -500\text{ }\mu\text{A} - 0\text{ }\mu\text{A}$ , $V_{DIM} = 3\text{ V}$		4.0	6.0	k $\Omega$
$R_{LEDSWLO}$	Low level output resistance	$I_{LEDSW} = 500\text{ }\mu\text{A} - 0\text{ }\mu\text{A}$ , $V_{DIM} = 0\text{ V}$		2.0	3.0	
$R_{DTY}$	DTY output resistance	$V_{DTY} = 0\text{ V} - 2.5\text{ V}$ , $V_{DIM} = 0\text{ V}$	30	40	50	
$V_{DTYH}$	DTY max level	$V_{DIM} = 0\text{ V}$	2.45	2.60	2.70	V
$V_{DTYL}$	DTY min level	$V_{DIM} = 3\text{ V}$	0.05	0.10	0.15	
$I_{DADJCH}$	DADJ charging current	$V_{DADJ} = 2.5\text{ V}$ , $V_{DIM} = 0\text{ V}$	16	20	25	$\mu\text{A}$
$R_{DADJDC}$	DADJ discharge resistance	$V_{DADJ} = 0.5\text{ V}$ , $V_{DIM} = 3\text{ V}$		1.0	1.5	k $\Omega$
$T_{DADJ}$	DADJ delay	$C_{ADJ} = 2.2\text{ nF}$ , $V_{DTY} = 2.6\text{ V}$ , delay from DIM high-to-low to DSR discharge	225	275	330	$\mu\text{s}$
$I_{DSRCH}$	DSR slew rate charge current	$V_{DSR} = 2.5\text{ V}$ , $V_{ICOMP} = 4\text{ V}$ , $V_{DIM} = 3\text{ V}$	38	44	50	$\mu\text{A}$
$I_{DSRDC}$	DSR slew rate discharge current	$V_{DSR} = 2.5\text{ V}$ , $V_{ICOMP} = 4\text{ V}$ , $V_{DIM} = 0\text{ V}$	38	44	50	
$V_{DSRCL}$	DSR clamp above ICOMP	$V_{ICOMP} = 2\text{ V}$ , level above $V_{ICOMP}$	0.45	0.70	0.95	V



SOIC 20-Pin (DW)  
Top View

DW Package  
(Top View)

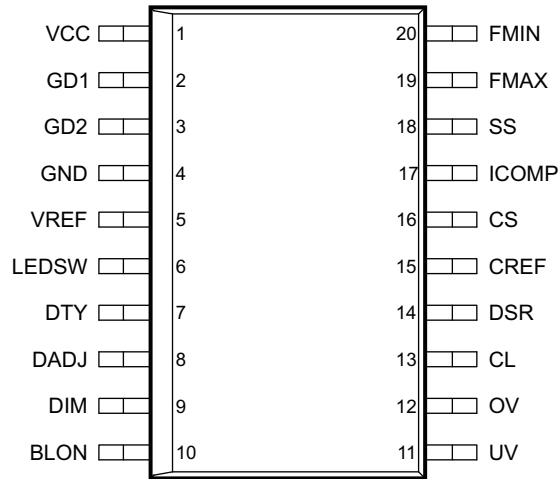

Terminal Functions

TERMINAL		I/O	DESCRIPTION
NAME	NO.		
BLON	10	I	<b>BackLight ON</b> is an enable signal for the control device. The signal is active high with a threshold of approx 1.2 V. The 5-V reference (VREF) is enabled with BLON which is the bias supply for many of the internal blocks of the device.
CL	13	I	<b>Current Limit</b> input connects to a signal that represents the power converter’s input current. Dual thresholds provide a shutdown retry or latch-off response.
CREF	15	I	<b>Current REFerence</b> is used to set the regulating voltage for the LED current feedback signal at the CS input. This voltage input is set using a resistor divider from VREF. A nominal level of around 0.7 V is recommended although a range of 0.6 V to 2.7 V is accommodated. Internal reference levels of 0.5 V and 2.8 V replace the CREF input voltage at the current amplifier when the CREF pin voltage is respectively below or above these levels. The 0.5-V internal reference can be achieved by shorting CREF to ground, the internal 2.8-V reference can be achieved by shorting CREF to VREF.
CS	16	I	<b>Current Sense</b> input monitors the LED current. This signal is compared to $V_{CREF}$ by the current amplifier to regulate the total LED current.
DADJ	8	I/O	A capacitor to ground at the <b>Duty-cycle ADJust</b> input sets the positive slope of a saw tooth waveform that is compared to a voltage proportional to 1-D where D is the dimming PWM duty-cycle of the DIM input. At the falling edge of the DIM input this comparison is used to extend the LLC on time beyond the on time of the LED series switch.
DIM	9	I	A PWM input signal at the <b>DIMming</b> pin controls the average load current by cycling on and off both an external series LED switch and the gate drives to the LLC converter. A high on this pin corresponds to an ON condition. The controller will ignore a low condition at this input during start up or fault recovery until after the completion of a soft-start sequence.
DSR	14	I/O	The <b>Dimming Slew Rate</b> pin is used to limit the rate of the VCO frequency change at the LLC on or off edges of a dimming PWM cycle. A capacitor to ground at this pin programs the maximum positive and negative slew rates that appear at the control input to the VCO. Pulling this pin below about 0.8 V will disable the GD outputs.
DTY	7	I/O	The <b>DuTY-cycle</b> pin is averaged with a capacitor to ground to form a 1-D proportional voltage that is compared to the $D_{ADJ}$ saw tooth voltage. The average voltage at this pin will be $2.5 V(1-D)+0.1 V$ , where D is the dimming PWM duty-cycle the DIM input.
FMAX	19	I/O	The <b>MAXimum Frequency</b> of the LLC converter is set by a resistor to ground at this pin. It is actually the difference between the maximum and minimum frequency that is set by this resistor.
FMIN	20	I/O	The <b>MINimum Frequency</b> of the LLC converter is set by a resistor to ground at this pin.
GD1&2	2, 3	O	<b>Gate Drive</b> outputs operate 180° out of phase with a fixed 500 ns of dead time. They typically will drive either primary end of a gate drive transformer. At start up or during a fault recovery, initiating the LLC converter begins with GD2 turning on first.

**Terminal Functions (continued)**

TERMINAL		I/O	DESCRIPTION
NAME	NO.		
GND	4	P	The <b>GROUND</b> pin is both the reference pin for the controller and the low-side return for the gate drive signals. Special care should be taken to return all AC decoupling as close as possible to this pin and avoid any common trace length with analog signal return paths.
ICOMP	17	O	This output pin is used to <b>COMPensate</b> the current regulating loop. A capacitor, or capacitor resistor series combination is typically used. During current regulation the voltage into the VCO is slaved to this pin. Pulling this pin below about 0.8 V will disable the GD outputs. During PWM dimming off-time this pin is tri-stated and the compensation network is meant to hold the proper LLC control voltage until the LLC converter is turned back on. To optimize this operation any DC loading on this pin should be avoided.
LEDSW	6	O	The <b>LED Switch</b> output is a control signal to a series LED switch. This output is low during a low level at the DIM input and whenever the LLC converter is disabled. PWM dimming is disabled during soft start, the LEDSW output will be high independent of the DIM input. A simple gate drive circuit is generally required at this output to drive the external FET.
OV	12	I	This pin is used to monitor for an <b>Over-Voltage</b> condition on an LED string. A level above $V_{OVTH}$ on this pin causes the converter to disable the gate drive outputs as well as the LEDSW output. If the OV input falls below its trip threshold the converter responds with a $T_{RSTDLY}$ (10 ms) reset delay and soft start.
SS	18	I/O	The <b>Soft-Start</b> pin is used to control the rate of change of the VCO frequency during start up. At start up a low value pull-up current source, $I_{SS}$ , is applied to this pin. A soft-start sequence is initiated at start up and during any fault recovery. The SS pin must charge to 4.2 V before the controller allows PWM dimming to take place.
UV	11	I	This pin is used to monitor for an <b>Under-Voltage</b> condition on the load. A level below $V_{UVTH}$ on this pin causes the converter to disable the gate drive outputs as well as the LEDSW output. Immediately, a $T_{RSTDLY}$ (10 ms) reset delay and soft-start sequence is initiated. The reset delay and soft-start sequence is repeated as long as the UV pin is low at the end of the sequence.
VCC	1	P	Connect a DC power voltage to VCC. Bypass VCC to GND with a 0.47- $\mu$ F or larger ceramic capacitor using short PC board traces. VCC directly supplies power to the gate drivers and VREF which biases all circuit blocks in the UCC25710. Under-voltage lockout (UVLO) comparator prevents operation until VCC rises above $V_{VCCON}$ .
VREF	5	O	The internal 5-V supply and <b>REference</b> rail is brought out to this pin. A small decoupling capacitor to ground of 1 $\mu$ F is required. VREF can support up to 10 mA current external to the device. VREF is enabled when VCC is above $V_{VCCON}$ and BLON is above $V_{BLON}$ .

**TYPICAL CHARACTERISTICS**

**SUPPLY CURRENT  
vs  
DIMMING DUTY CYCLE**

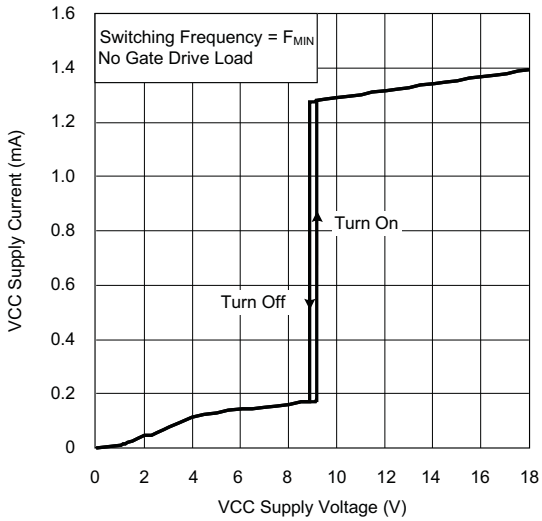

**Figure 1.**

**$V_{VCCON}$  AND  $V_{VCCOFF}$  THRESHOLD  
vs  
TEMPERATURE**

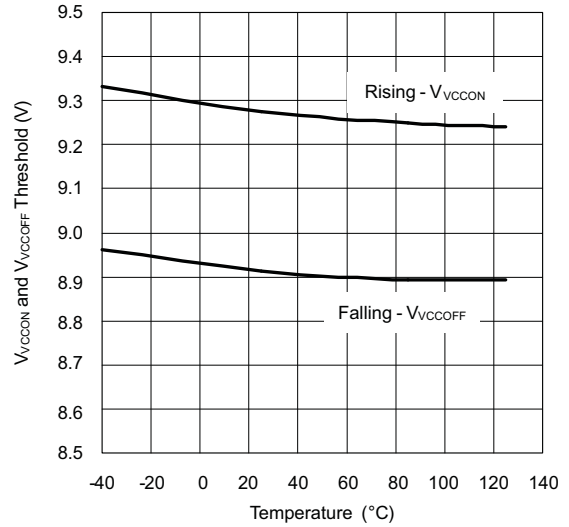

**Figure 2.**

**SUPPLY CURRENT  
vs  
TEMPERATURE**

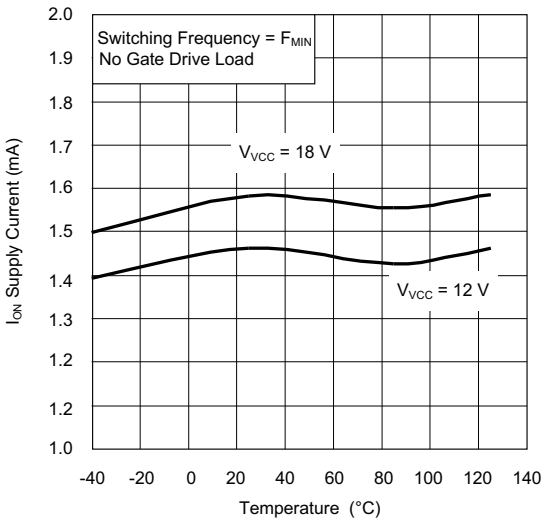

**Figure 3.**

**$I_{DISABLE}$  AND  $I_{OFF}$  SUPPLY CURRENT  
vs  
TEMPERATURE**

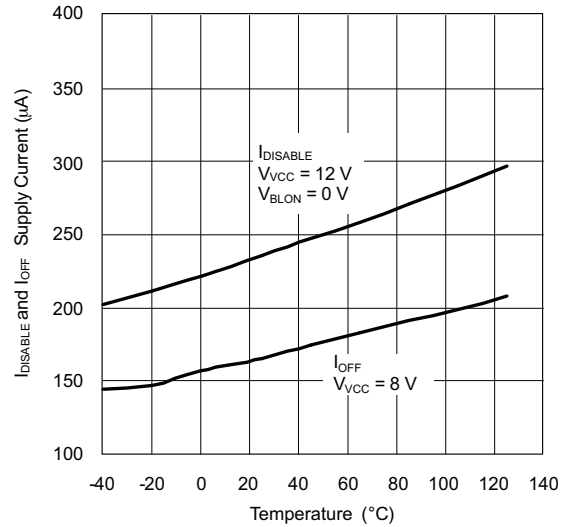

**Figure 4.**

TYPICAL CHARACTERISTICS (continued)

REFERENCE VOLTAGE  
vs  
TEMPERATURE

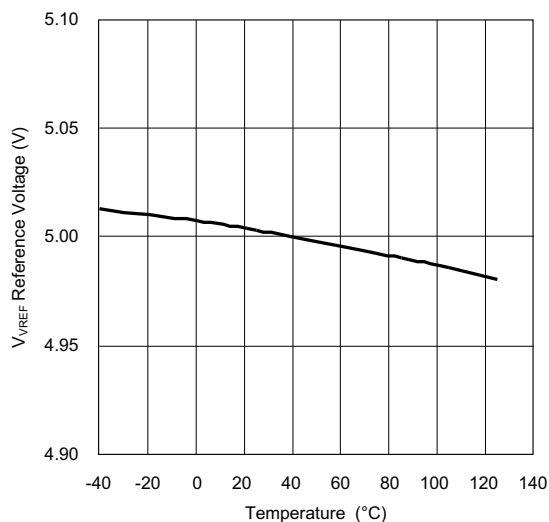

Figure 5.

OUTPUT CURRENT (I<sub>COMP</sub>)  
vs  
INPUT VOLTAGE (CS)

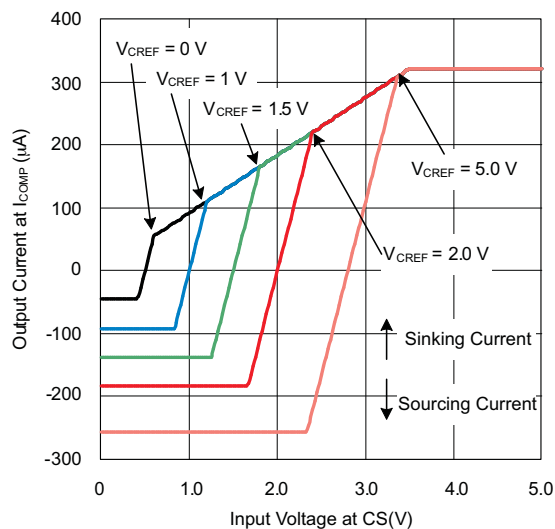

Figure 6.

GM<sub>I<sub>COMP</sub></sub>  
vs  
TEMPERATURE

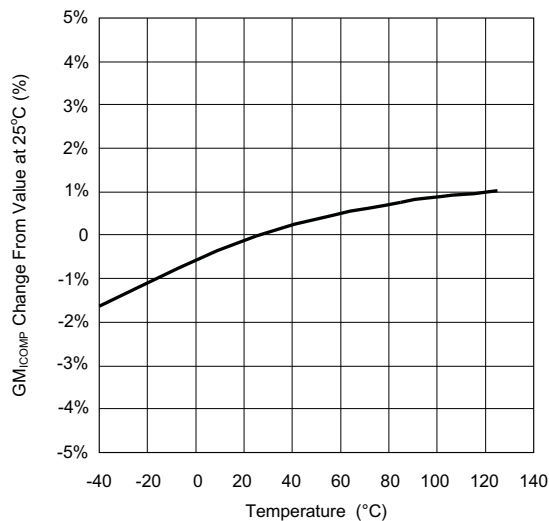

Figure 7.

MINIMUM SWITCHING FREQUENCY  
vs  
TEMPERATURE

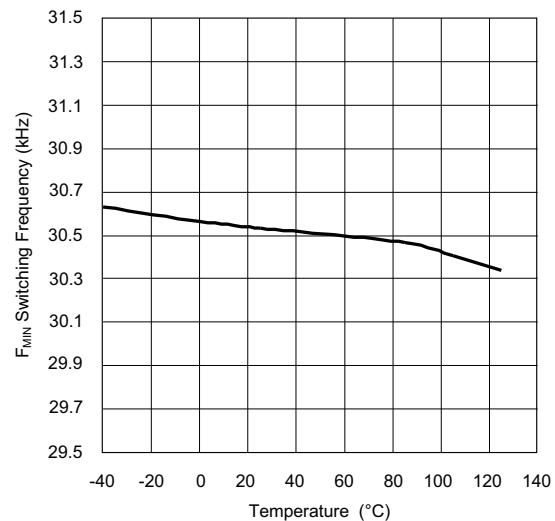

Figure 8.

**TYPICAL CHARACTERISTICS (continued)**

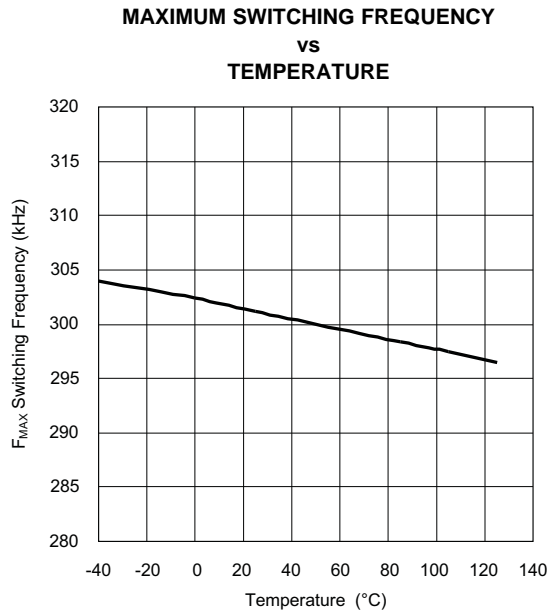

Figure 9.

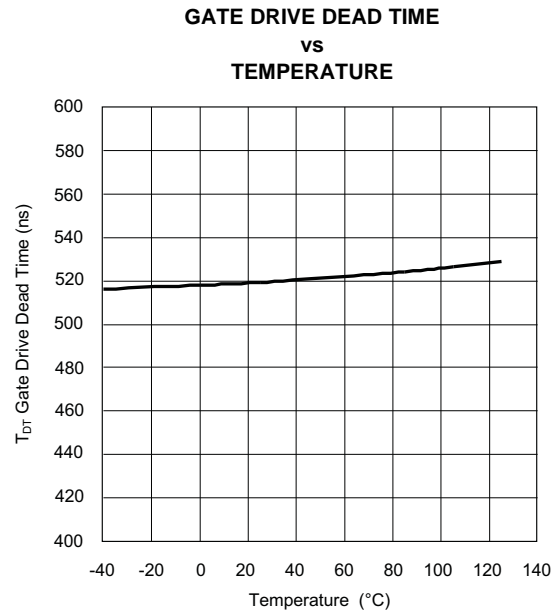

Figure 10.

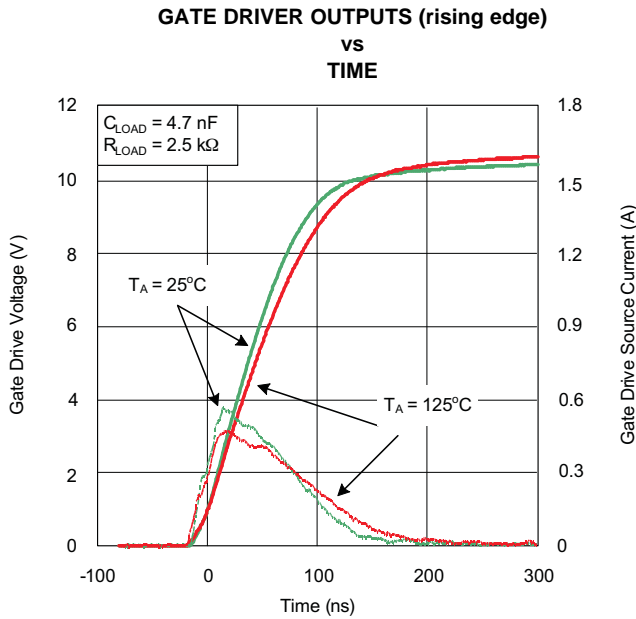

Figure 11.

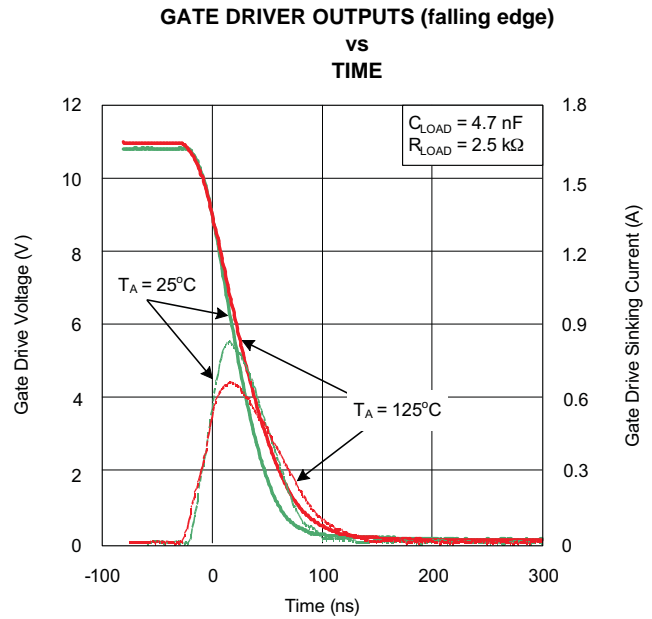

Figure 12.

TYPICAL CHARACTERISTICS (continued)

DSR CURRENTS  
vs  
TEMPERATURE

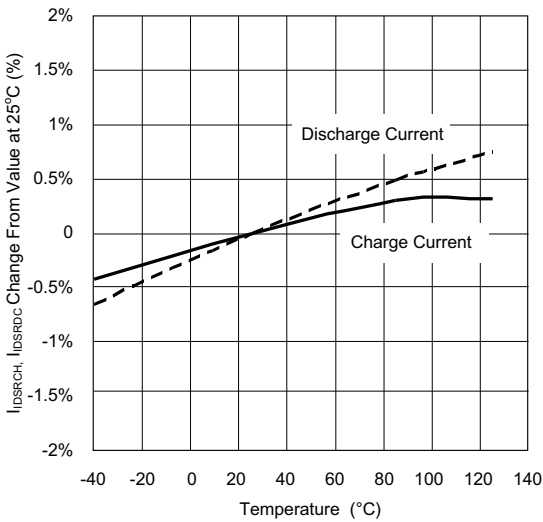

Figure 13.

LLC ON-TIME EXTENSION  
vs  
DIMMING DUTY CYCLE

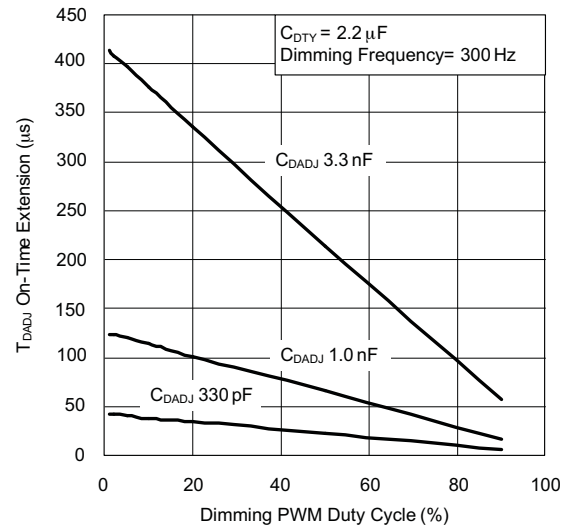

Figure 14.

LLC ON-TIME EXTENSION  
vs  
TEMPERATURE

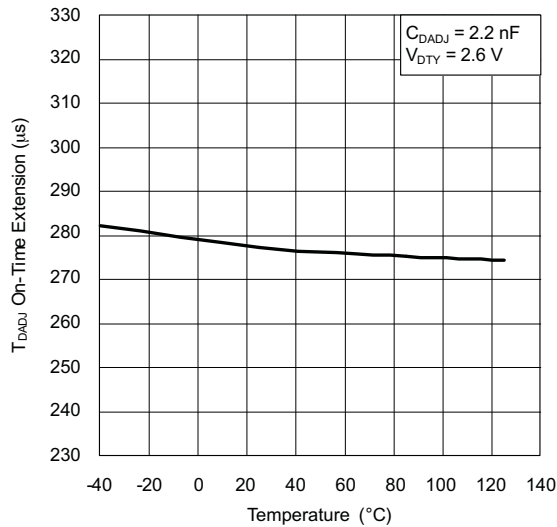

Figure 15.

LEDSW RISE AND FALL  
vs  
TIME

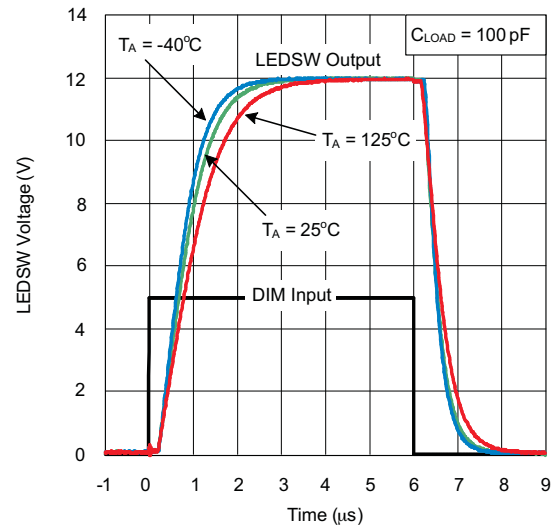

Figure 16.

## APPLICATION INFORMATION

### FUNCTIONAL DESCRIPTION

Signal names and pin functions are depicted in the UCC25710 block diagram in this datasheet.

#### Multi-transformer Architecture

The multi-transformer LED driver architecture is a very attractive solution for driving multiple LED strings at the same current utilizing a single power train and control device. Excellent LED string current matching from string to string (<1%) excellent LED current linearity from 1% to 100% dimming (<2%), and high efficiency can be achieved (>94%). Since this architecture is intended to utilize the 400-V output of the PFC stage, there is a significant cost advantage over typical LED backlight implementations since a power stage can be eliminated.

The architecture and UCC25710 control device are based on the LLC resonant half-bridge topology. The controller feedback loop is configured to regulate the total LED current typically with a current sense resistor. The arrangement of the transformers with the primaries in series provides excellent LED string current matching. Since the primaries are in series, the current in each transformer primary is the same. The secondary current is the primary current times the turns ratio. The net primary magnetizing current is circulated in the primary side of the half bridge and does not affect the current transferred to the outputs. In each transformer, differences in magnetizing current caused by different magnetizing inductance or winding voltage will cause a difference in current transferred to the LED outputs, although the difference in transferred current is minimal with typical transformer tolerances and following the guidance in the [Determining Transformer and Resonant Circuit Parameters](#) below.

The UCC25710 includes all of the functions necessary to implement a total LED backlight driver including GM current amplifier, VCO, reference regulator, soft start, dimming duty cycle compensation and protection for OV, UV, current limit, and thermal shut down. There are additional features to minimize audible noise during dimming and provide fast LED current rise and fall times.

## Start-Up and Non-Dimming Operation

The UCC25710 is enabled when  $V_{CC}$  exceeds the  $V_{VCCON}$  threshold and BLON is high. At this time the soft-start cycle is initiated following a 10-ms reset delay. A 2.5- $\mu$ A current source charges the capacitor connected to the SS pin to generate the soft-start ramp. During the soft-start cycle the current amplifier output (ICOMP) is clamped to be equal to or less than SS voltage. The voltage on ICOMP controls the VCO.  $V_{ICOMP}$  will achieve the steady state operating point to regulate the total LED current during the soft-start rise time. The DIM input and the UV input are disabled during soft start to allow the output capacitors to charge to the steady state operating voltage. When the SS pin reaches the  $V_{SSTH}$  threshold the SS-END signal transitions high indicating the end of the soft start cycle. At this time the UV comparator and DIM input are enabled. Refer to Figure 17 for the timing relationship during soft start.

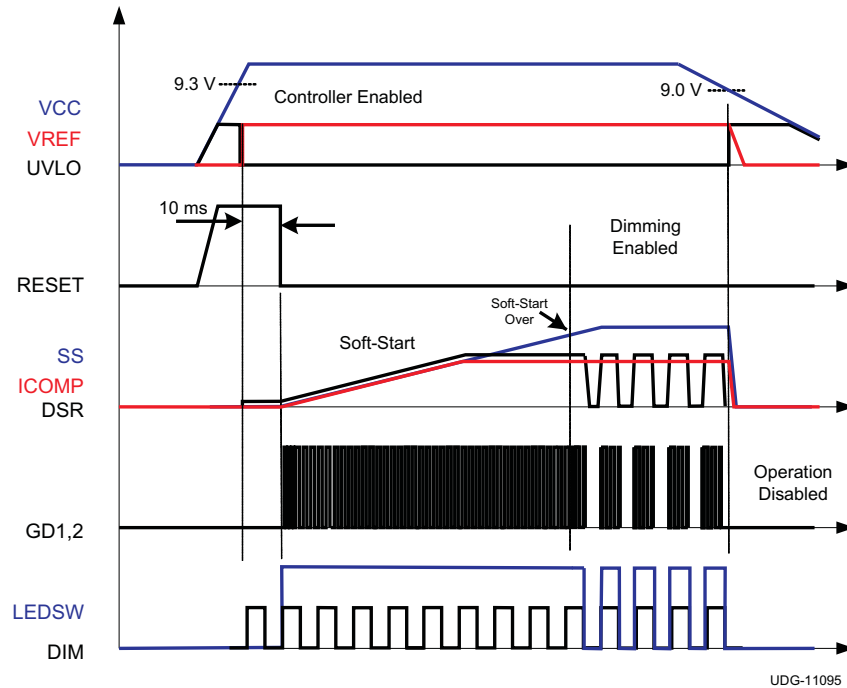

Figure 17. Start-Up Timing Diagram

### Dimming Operation

Once the soft-start cycle is complete, the LEDSW output and control of the VCO depend on the DIM input. The dimming input signal controls the LEDSW output maintaining an accurate on-time relationship between the DIM pulse width and LED current pulse width; the internal control signal is LED-ON. The LED-ON signal also controls a switch between the GM current amplifier output and the ICOMP pin. On the DIM rising edge the switch from the amplifier to the ICOMP pin is turned on after a 2.4-μs delay. The small delay time allows time to turn on the LED switch MOSFET. On the DIM falling edge the switch between the GM amplifier is turned off. During the DIM off-time the compensation capacitor at the ICOMP pin holds the correct steady-state operating voltage for the current loop. It is important that any DC loading of this pin is kept to an absolute minimum or current errors will result as the dimming duty-cycle is reduced.

The LLC power stage is gated on and off during dimming with the dimming input signal. The UCC25710 allows control of the slew rate of the LLC power delivery at the rising and falling edges of a dim cycle allowing potentially audible electro-mechanically induced noise to be minimized. In addition, the falling, or turn-off, edge of a dimming cycle can be delayed, allowing the current loop to maintain control at low dimming duty-cycles even when the ramp rates have been slowed. This is pictured in Figure 18.

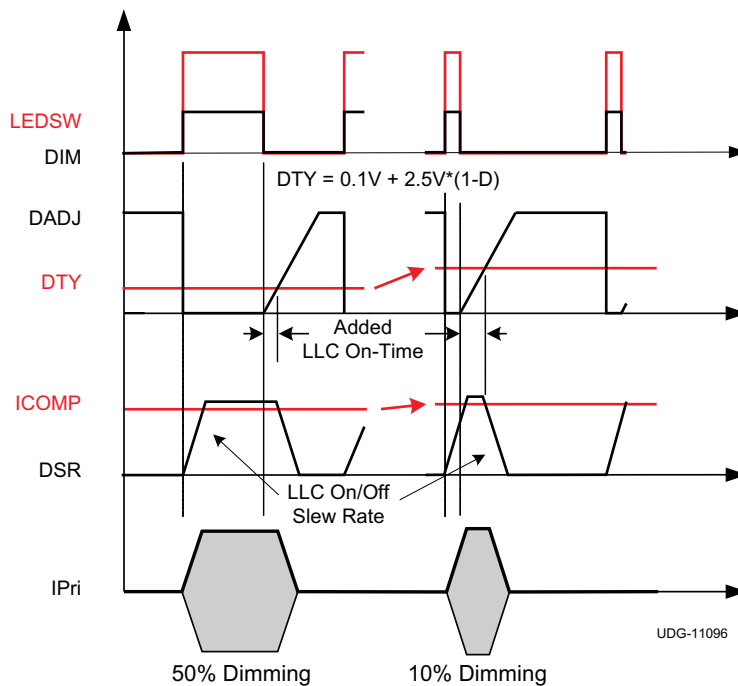

Figure 18. Dimming Timing Diagram

The power through the LLC converter is inversely proportional to the frequency of the VCO. The VCO frequency, in turn, is inversely proportional to the VCO control signal. See Figure 19 for details of this relationship. The dimming input generates an LLC-OFF signal that is used to select either a charging or discharging state for a capacitor applied to the DSR pin. The +/-44  $\mu$ A of current and associated capacitor set a ramp rate for the rise and fall of the DSR voltage. The control voltage to the VCO is dominated by the DSR voltage when the DSR voltage is less than the ICOMP pin – allowing the falling ramp on the DSR pin to softly turn-off the LLC power stage and softly return it to the same operating state as it rises.

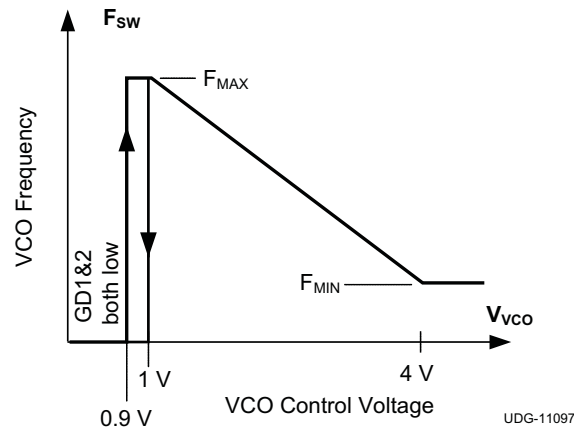

Figure 19. VCO Characteristics

The LLC-OFF signal is an inverted version of the dimming input signal. The falling edge of LLC-OFF is synchronized with the rising edge of the DIM signal. At a negative DIM edge the DADJ and DTY signals are combined to delay the rising edge of LLC-OFF providing a duty-cycle compensation time that is a function of the dimming duty cycle.

Averaged by a capacitor at the DTY pin, the voltage on DTY is inversely proportional to the dimming duty cycle; the voltage is

$$0.1 \text{ V} + 2.5 \text{ V} \times (1-D),$$

where:

- D is the dimming PWM duty-cycle

The DTY voltage range is 100 mV at 100% DIM duty-cycle, or LED current continuously on, to 2.6 V at 0% DIM duty cycle, or LED current continuously off. The DADJ pin 20- $\mu$ A current source is allowed to charge the pin capacitor after a DIM falling edge. The LLC-OFF signal transitions high when the capacitor on DADJ charges to the voltage on DTY. Refer to Figure 18 for the timing relationship during dimming. The scope plots in Figure 20 and Figure 21 below show an example LED driver at 10% and 50% DIM duty cycle.

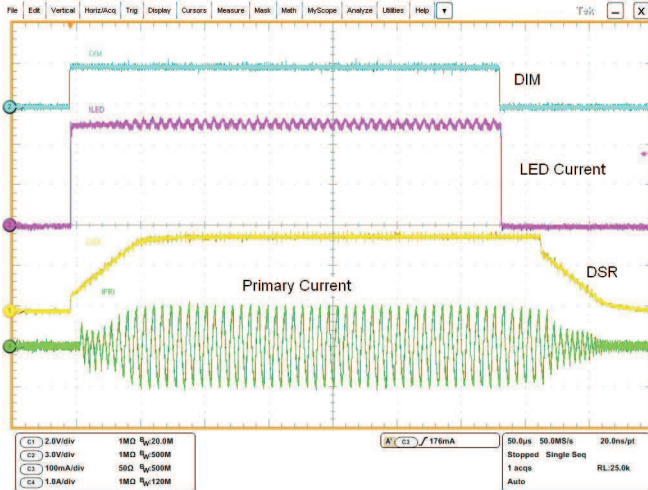

Figure 20. DIM 10% at 300 Hz

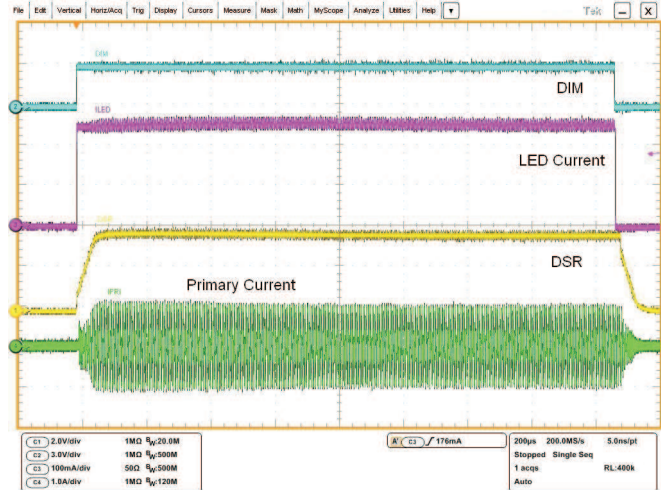

Figure 21. DIM 50% at 300 Hz

### Fault Condition Operation

The UCC25710 has a similar response to over-voltage, thermal shut down and current limit faults. This fault response is shown in Figure 22. The OV input has a 2.6-V threshold and 240 mV of hysteresis. When OV is above 2.6 V the internal FAULT signal is active which results in the RESET signal going high. With RESET high the gate drivers are disabled, the SS pin is discharged to ground, and the LEDSW output is turned off. When OV is below 2.36 V the FAULT signal is inactive which starts the 10-ms SS clamp timer.

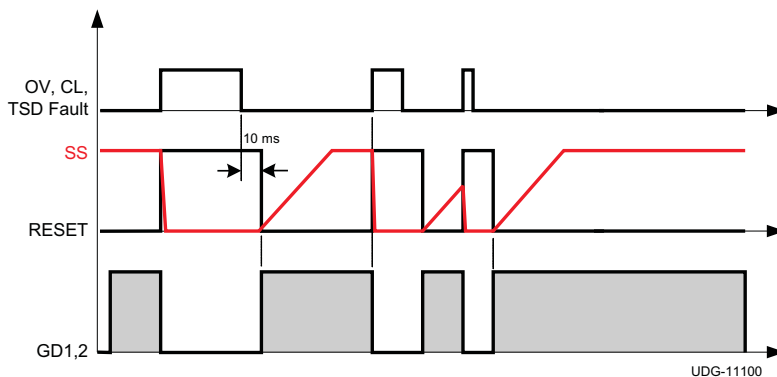

Figure 22. OV, CL(1 V) and TSD Fault Timing Diagram

RESET is extended 10 ms beyond FAULT going low. After the 10-ms soft-start timer the normal soft-start sequence begins. Thermal shut down generates the same internal FAULT signal when the internal temperature reaches 160°C and a restart sequence begins after the junction temperature drops by the 25°C of threshold hysteresis.

The current limit comparator has two thresholds. The lower threshold of 0.95 V results in a shut down and restart as described for OVP, the OC pin has 0.475 V of hysteresis. The second current limit threshold of 1.9 V results in a latch off fault. VCC must be recycled below the  $V_{CCOFF}$  threshold to reset the latched OC fault.

The under-voltage fault has a different response in order to allow the converter to charge the output capacitors in a normal start-up condition. Since UV is disabled during soft start, a sustained UV fault results in a 10-ms soft-start clamp time plus the time required for the SS pin to charge to  $V_{SSTH}$  which is 4.15 V. Refer to Figure 23 for UV fault condition timing diagrams.

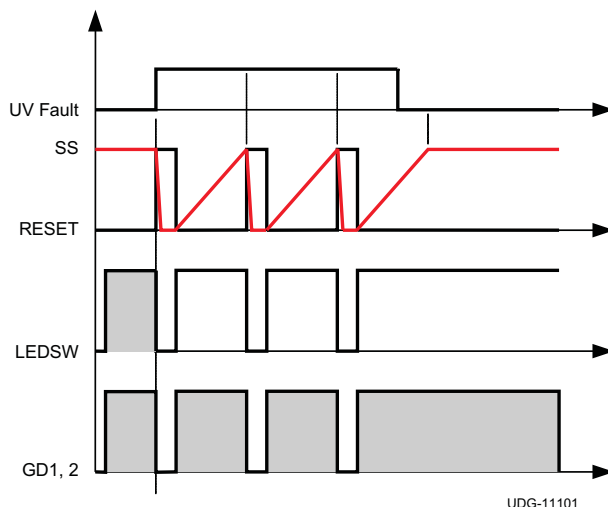

Figure 23. UV Fault Timing Diagram

## Determining Transformer and Resonant Circuit Parameters

The multi-transformer architecture is similar to conventional LLC converter design with a few exceptions that are described in this section. Typical LLC voltage output converters are designed to operate nominally close to resonance and have the minimum switching frequency below resonance and maximum frequency above resonance. It is recommended to operate above resonance at the nominal input voltage range of the converter in order to achieve good transient response during dimming and improved LED current matching. The transformer turns ratio equation shown is to target operation above resonance.

The equation below is used to calculate the turns ratio of the transformers in the multi-transformer architecture.

$$N = \frac{N_P}{N_S} = \frac{V_{IN}}{2 \times N_T \times V_{LED}} \quad (1)$$

Where:

- $N$  is the primary to secondary turns ratio
- $N_P$  is the primary turns
- $N_S$  is the secondary turns
- $V_{IN}$  is the input voltage to the LLC converter, typically the output of the PFC boost converter
- $N_T$  is the number of transformers
- $V_{LED}$  is the LED string voltage

Another important consideration for the multi-transformer LED driver is to set the total magnetizing inductance of the transformers as high as possible to minimize the primary magnetizing current and its effect on LED current matching. We recommend targeting the total magnetizing inductance of the transformers to a value just low enough to achieve ZVS operation during nominal frequency operation. Below are the equations to determine the magnetizing inductance target. Reduce the calculated  $L_M$  to accommodate  $L_M$  and  $C_{OSS}$  tolerances.

$$I_{MPK} = \frac{2 \times C_{OSS} \times V_{IN}}{400 \text{ ns}} \quad (2)$$

$$L_M = \frac{V_{IN} \times \left( \frac{0.5}{F_{SW}} - 500 \text{ ns} \right)}{4 \times I_{MPK} \times N_T} \quad (3)$$

Where:

- $I_{MPK}$  is the peak magnetizing current
- $C_{OSS}$  is the MOSFET equivalent time related drain to source capacitance
- $V_{IN}$  is the nominal input voltage to the half bridge, normally the PFC output voltage
- $F_{SW}$  is the switching frequency at the regulation operating point
- $L_M$  is the magnetizing inductance of each transformer
- $N_T$  is the number of transformers with the primaries in series

In order to use standard LLC converter design process and available tools such as SLUC253 design calculator available on the TI website, the multiple transformers and reflected loads can be combined into one equivalent transformer and load as shown in Figure 24 below. Once  $L_r$  and  $L_m$  are determined based on a single transformer circuit; simply divide by the number of transformers for each transformer specification target.

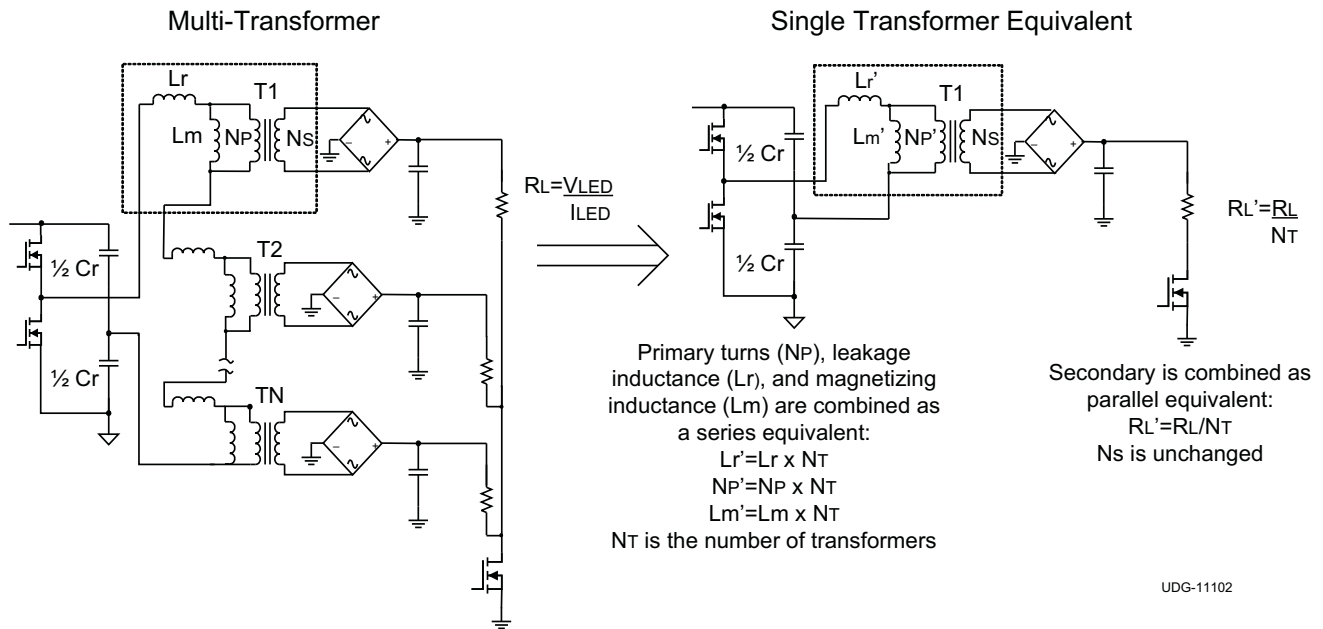

**Figure 24. Multiple Transformers Combined With Reflected Loads**

## PIN COMPONENT SELECTION

### CS (Output Current Sense)

The CS pin is connected to the output current sense resistor and is the feedback signal for the current amplifier. The regulation range is limited by the 0.5 V to 2.8 V internal current amplifier reference clamp. The LED current sense resistor value is determined by the equation below.

$$R_{CS} = \frac{V_{CREF}}{I_{LEDTotal}} \quad (4)$$

Where:

- $V_{CREF}$  is voltage on CREF pin determined by divider from VREF  $I_{LEDTotal}$ .
- $I_{LEDTotal}$  is the total LED string current during the DIM on time.

### ICOMP (Current Amplifier Compensation)

Connect a capacitor or series resistor capacitor combination to ground to compensate the 510- $\mu$ S GM current amplifier control loop. The current amplifier is designed to maintain the steady state operating voltage point of the current amplifier during dimming operation. This is accomplished by switching on and off the GM current amplifier to the ICOMP pin with the same control signal that controls the LEDSW output. The GM amplifier is disconnected from the ICOMP pin during the DIM off-time, and connected during the DIM on-time. This feature will be compromised if there is a leakage path on the ICOMP pin, such as resistance to ground. The re-connection of the ICOMP pin to the current amplifier output is delayed by about 2.4  $\mu$ s to allow time for the external LED switch to be turned on prior to allowing the ICOMP pin voltage to be driven.

The optimum ICOMP capacitor value is determined based on desired LED current and primary current response during dimming. Since the LLC converter has a highly nonlinear transfer function, a gain phase analyzer is recommended to optimize the component values on ICOMP. The recommended bandwidth target is from 800 Hz to 5 kHz. The tradeoff of too low bandwidth is increased line frequency ripple on the LED string current. The tradeoff of high bandwidth is voltage variation on ICOMP during the DSR rise time which can result in primary current peaking during the start of the DIM period, this may result in audible noise if excessive. Either an integrator (capacitor to ground) or type II compensation (capacitor in parallel with resistor and series capacitor) is recommended.

### SS (Soft Start)

Connect a capacitor to ground to program the desired soft start time. When VCC exceeds the  $V_{CCON}$  threshold and BLON is high, a 2.5- $\mu$ A current source charges the soft start capacitor after a 10-ms delay. The voltage on SS dominates the VCO control voltage when lower than  $V_{ICOMP}$  or  $V_{DSR}$ . The device is in a soft-start condition until  $V_{SS}$  reaches the 4.2-V soft-start over threshold. During the soft-start cycle DIM is disabled and the UV protection is disabled. The soft-start cycle is initiated by UVLO, BLON, OV fault clear, or UV fault clear after the soft start cycle.

$$C_{SS} = \frac{2.5 \mu A \times T_{SS}}{V_{ICOMP\_REG} - 0.9 V} \quad (5)$$

Where:

- $T_{SS}$  is the target SS time.
- $V_{ICOMP\_REG}$  is the ICOMP voltage at the regulation point, which can be derived based on LLC switching frequency.

### FMAX (Maximum VCO Frequency)

Terminate FMAX to ground with a resistor to program the frequency delta from desired maximum to minimum operating frequency range. The recommended resistor value range is 4.22 kΩ to 53.6 kΩ.  $V_{ICOMP}$  which is the VCO control signal determines the voltage on FMAX; the programming resistor determines the voltage to current conversion ratio that programs the oscillator frequency at a given  $V_{ICOMP}$  voltage level. The device is designed to accommodate a maximum frequency of 350 kHz and a minimum frequency delta of 25 kHz. To provide controlled rise and fall time of the primary current during dimming, a maximum frequency of 2 to 3 times the nominal switching frequency is recommended as an initial value. The resistor value can be determined by the following equation.

$$R_{MAX} = \frac{0.0664}{49.2\text{pF} \times F_{SW}(\text{Delta})} \quad (6)$$

Where:

- $F_{SW}(\text{Delta}) = F_{SW(\text{max})} - F_{SW(\text{min})}$

### FMIN (Minimum VCO Frequency)

Terminate FMIN to ground with a resistor to program the desired minimum operating frequency. The recommended resistor range is 9.53 kΩ to 102 kΩ. The device is designed to accommodate a minimum frequency of 30 KHz. The resistor value can be determined by the following equation.

$$R_{MIN} = \frac{0.15}{49.2\text{pF} \times F_{SW(\text{min})}} \quad (7)$$

The following equation is used to determine  $F_{SW}$  for given  $V_{ICOMP}$ ,  $R_{FMAX}$ , and  $R_{FMIN}$  values.

$$F_{SW} = \frac{\frac{0.15}{R_{MIN}} + \frac{(4V - V_{ICOMP})}{R_{MAX} \times 45.2V}}{49.2\text{pF}} \quad (8)$$

Where:

- From [Equation 6](#) to [Equation 8](#),  $F_{SW}$  is in Hz, R is in Ω,  $V_{ICOMP}$  is in V.

## GD1 and GD2 (Gate Drive 1 and 2)

Connect the primary of the gate drive transformer to GD1 and GD2 through a small series resistance. The high-side driver resistance is 12  $\Omega$  and low-side driver resistance is 4  $\Omega$  typical. The drivers are limited to 25-mA RMS maximum current, so there is a magnetizing current limitation of the gate-drive transformer shown in [Equation 9](#). If the magnetizing current exceeds 25 mA with the specified gate-drive transformer and nominal operating frequency, a simple NPN-PNP buffer on GD1 and GD2 may be required. The minimum gate drive transformer inductance can be determined from [Equation 9](#).

$$L_{GD} = \frac{V_{CC}}{2 \times F_{SW} \times 87 \text{mA}} \quad (9)$$

Where:

- $L_{GD}$  is the gate drive transformer  $L_{PRI}$
- $F_{SW}$  is the nominal switching frequency
- $V_{CC}$  is the  $V_{CC}$  supply voltage

## LEDSW (LED Switch Drive)

The LEDSW is the output to control the LED switch MOSFET in series with the LED string returns. The LEDSW is controlled by the DIM input during normal operation to provide LED string current pulse widths that corresponds to the DIM signal. During soft start, the LEDSW signal is high regardless of the DIM signal to allow the output capacitors to charge. The LEDSW is low during an OV, UV or CL fault to provide additional protection to the LED's. This output is 0 V to  $V_{CC}$  but has limited drive current ability, a simple NPN/PNP buffer is required to drive the LED switch MOSFET. The LEDSW high resistance is 4 k $\Omega$  and low side is 2 k $\Omega$  so avoid any DC load on this pin.

The turn-on and turn-off delay of the LED switch MOSFET relative to DIM rising and falling edge must be well matched to achieve excellent LED current linearity especially at low DIM duty-cycles. As an example, consider a 1% dimming duty-cycle at dimming PWM frequency of 300 Hz where a delay mismatch of 667 ns represents a 2% linearity error. A gate drive resistor and parallel resistor diode combination to drive the LED switch MOSFET can be used to match edge delays. Refer to [Figure 25](#) for a recommended LED switch MOSFET drive circuit.

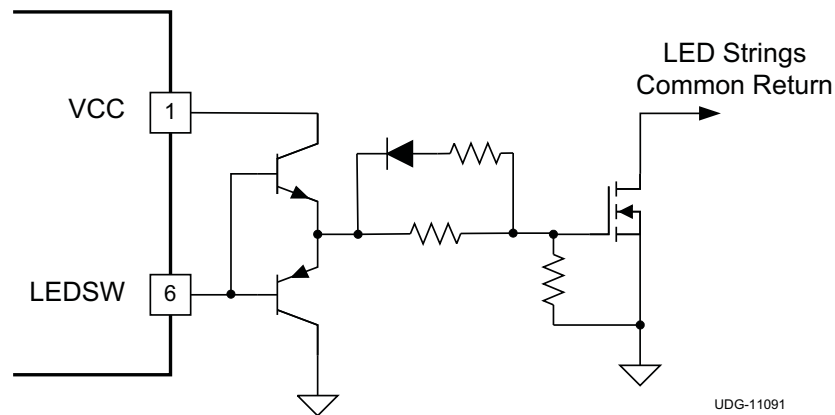

**Figure 25. Recommended LED Switch MOSFET Drive Circuit**

### DSR (Dimming Slew Rate)

The DSR pin is used to control the rise and fall time of the VCO control voltage. The DSR capacitor value can be determined by the equation below. The effective rise time of the LLC primary current is when VDSR is between the 0.9V gate drive enable voltage and the VICOMP operating point.

$$C_{DSR} = \frac{44 \mu A \times T_{SLEW}}{V_{ICOMP\_REG} - 0.9 V} \quad (10)$$

Where:

- $T_{SLEW}$  is the desired LLC current rise and fall time
- $V_{ICOMP\_REG}$  is the ICOMP voltage regulation point

Since the DSR voltage starts at 0 V and the LLC gate-drive enable is typically 0.9 V, there is a delay from the DIM rising edge and LEDSW rising edge until the LLC gate drivers are enabled. An easy solution to eliminate a majority of the delay is to use a resistor in series with  $C_{DSR}$ . Since DSR is clamped at a  $V_{be}$  above  $V_{ICOMP}$ , the recommended resistance is 15 k $\Omega$  to 17 k $\Omega$  to provide a 640-mV to 720-mV initial voltage delta.

### DTY (Dimming Duty-Cycle Average)

The DTY pin generates a voltage inversely proportional to the DIM duty-cycle with a 100-mV offset. The voltage range is 100 mV to 2.6 V corresponding to 100% dimming and 0% dimming. This voltage is compared to the DADJ rising ramp to determine the dimming duty-cycle compensation delay time.

The capacitor value is selected to provide low ripple voltage at the DIM frequency. A good guideline is to target 100 V or less peak-to-peak ripple voltage. There is a tradeoff of DTY capacitor value and response to DIM duty-cycle transients. For faster response time to significant changes in DIM duty-cycle select a lower value capacitance. The equation below can be used to select a DTY capacitor based on maximum ripple voltage and DIM frequency.

$$C_{DTY} = \frac{15.65 \mu A}{V_{DTY(pp)} \times F_{DIM}} \quad (11)$$

Where:

- $F_{DIM}$  is the dimming frequency
- $V_{DTY(pp)}$  is the maximum peak to peak ripple voltage.

The equation below can be used to determine the average of  $V_{DTY}$  at any given DIM duty-cycle.

$$V_{DTY} = [(1 - D_{DIM}) \times 2.5 V] + 0.1 V \quad (12)$$

Where:

- $D_{DIM}$  is the DIM duty-cycle.

### DADJ (Dimming Duty-Cycle Adjust)

The DADJ pin is a 20- $\mu$ A current source enabled at the DIM falling edge. The capacitor connected to this pin determines the slope of  $V_{DADJ}$ . LLC-OFF is the internal signal that controls the turn-on and turn-off of the LLC power stage. The rising edge of LLC-OFF corresponds to a falling edge at the DIM input. The falling edge of the LLC-OFF signal is delayed until the rising edge of the DADJ voltage crosses the voltage on DTY. Refer to [Dimming Operation](#) discussion for more details.

An initial value DADJ capacitor can be determined by the equation below. The dimming performance at lowest DIM on time should be evaluated as described in the following paragraph.

$$C_{DADJ} = \frac{20\mu A \times \left( \sqrt{\frac{DIM_{DMIN} \times T_{RISE}}{F_{DIM}}} - \frac{DIM_{DMIN}}{F_{DIM}} \right)}{\left[ (1 - DIM_{DMIN}) \times 2.5V \right] + 0.1V} \tag{13}$$

Where:

- $DIM_{DMIN}$  is the minimum dimming duty cycle
- $F_{DIM}$  is the dimming frequency
- $T_{RISE}$  is the effective DSR rise time

In order to ensure consistent LED current regulation during DIM duty-cycle transients it is important to confirm that ICOMP achieves the steady state operating voltage at the lowest DIM duty-cycle. Since DSR is clamped a  $V_{BE}$  (~0.7 V) above ICOMP this signal can be inspected to confirm a steady state operating point is achieved after the programmed DSR rise time. Confirm that the DSR signal achieves a relatively flat voltage during the lowest DIM duty-cycle condition. [Figure 26](#) and [Figure 27](#) below are scope plots of 1% DIM duty-cycle where DSR reaches the steady state operating point, and 0.5% DIM where DSR is still rising and ICOMP is open loop. If DSR is still rising during the lowest DIM duty cycle, increase the DADJ capacitor value until DSR achieves a relatively flat response as shown in [Figure 26](#), the 1% DIM duty-cycle scope plot below.

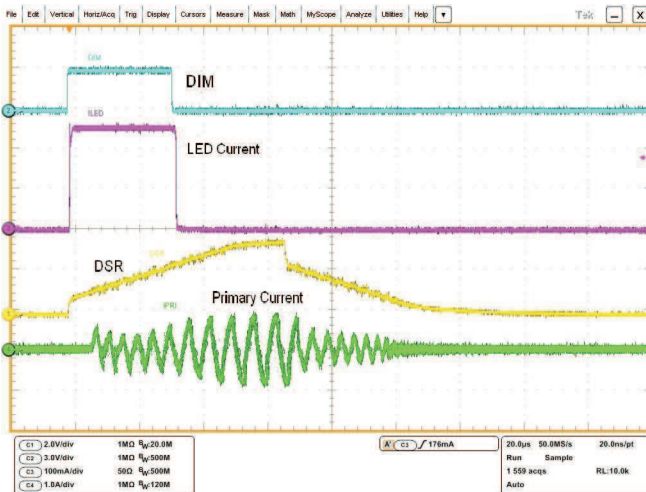

Figure 26. 1% DIM duty-cycle

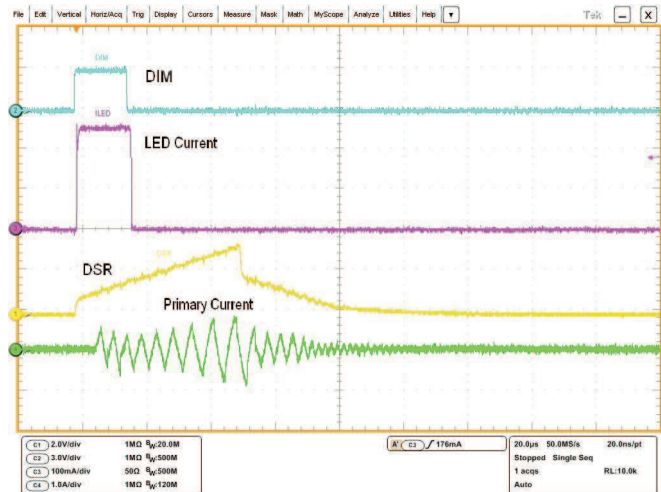

Figure 27. 0.5% DIM duty-cycle

### OV (Output Over Voltage)

The OV pin is connected to an output-voltage sense resistor divider with oring diodes to all of the LED outputs. The OV threshold is 2.6 V with 240-mV hysteresis. During an OV fault the GD1 and GD2 gate drivers are disabled and the LEDSW goes low (off). When the OV fault clears, the soft-start cycle is initiated.

A configuration is shown in Figure 28 below that allows for summing of multiple LED string outputs into common UV and OV dividers. The total resistance of the divider networks needs to be considered since the divider bias current will be provided by the highest voltage LED string. The following procedure can be used to determine total divider resistance and each component values.

$$R_{OV1} = \frac{2 \times V_{OUT} \times 1.5}{I_{OUT} \times D_{MIN} \times I_{MATCH}} \tag{14}$$

Where:

- $V_{OUT}$  is LED string voltage
- $I_{OUT}$  is LED DC output current
- $D_{MIN}$  is minimum dimming duty-cycle
- $I_{MATCH}$  is LED current matching target
- OV and UV dividers are approximately equal resistance

$$R_{OV2} = \frac{R_{OV1} \times 2.6V}{V_{OVLO} - 2.6V - V_D} \tag{15}$$

Where:

- $V_{OVLO}$  is the OVP threshold
- $V_D$  is the summing diode voltage drop

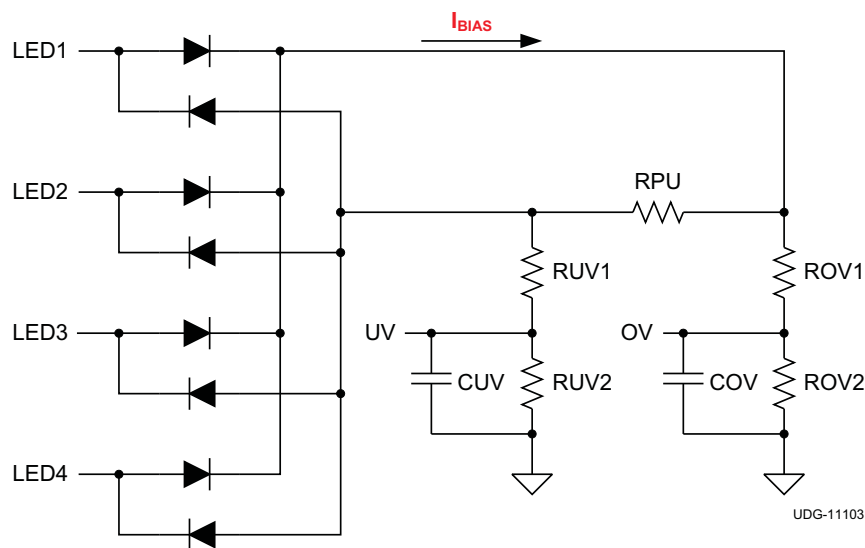

Figure 28.

## UV (Output Under Voltage)

UV is connected to an output-voltage sample of the converter. The UV threshold is 2.4 V with 240-mV hysteresis. UV below 2.4 V is considered an under-voltage fault which disables the GD1 and GD2 gate drivers, LEDSW output goes low, the 10-ms soft-start clamp and soft-start cycle are initiated. The UV comparator is disabled until SS voltage is 4.2 V to allow the output capacitors to charge to the normal operating voltage during start up of the converter.

Refer to the OV and UV divider diagram above for a typical configuration that allows for summing of multiple LED string outputs into common UV and OV dividers. The value of R<sub>PU</sub> needs to be considered to avoid a current path from the highest voltage LED string to the lowest voltage LED string. The following equations will assume a 2x V<sub>OUT</sub> delta as the maximum UVLO voltage.

$$R_{PU} = \frac{R_{OV1}}{5} \quad (16)$$

Where:

- LED voltage total tolerance is ±5%
- OV and UV dividers are approximately equal resistance

$$R_{UV1} = R_{OV1} - R_{PU} \quad (17)$$

$$R_{UV2} = \frac{(R_{UV1} + R_{PU}) \times 2.4 \text{ V}}{V_{UVLO} - 2.4 \text{ V} - V_D} \quad (18)$$

Where:

- V<sub>UVLO</sub> is the UVP threshold
- V<sub>D</sub> is the summing diode voltage drop

## CL (Current Limit)

The CL pin is typically connected to the rectified and filtered output of a primary current sense transformer. There are two levels of current limit protection, restart and latching. When CL exceeds 0.95 V the gate drivers are disabled and LEDSW goes low, when the CL voltage reduces to 475 mV the soft-start cycle is initiated. If CL exceeds a 1.9-V threshold, the gate drivers are disabled and LEDSW goes low, this condition is latched until VCC is recycled below the UVLO threshold.

**PACKAGING INFORMATION**

Orderable Device	Status (1)	Package Type	Package Drawing	Pins	Package Qty	Eco Plan (2)	Lead/Ball Finish	MSL Peak Temp (3)	Op Temp (°C)	Top-Side Markings (4)	Samples
UCC25710DW	ACTIVE	SOIC	DW	20	25	Green (RoHS & no Sb/Br)	CU NIPDAU	Level-1-260C-UNLIM	-40 to 125	UCC25710	<a href="#">Samples</a>
UCC25710DWR	ACTIVE	SOIC	DW	20	2000	Green (RoHS & no Sb/Br)	CU NIPDAU	Level-1-260C-UNLIM	-40 to 125	UCC25710	<a href="#">Samples</a>

(1) The marketing status values are defined as follows:

**ACTIVE:** Product device recommended for new designs.

**LIFEBUY:** TI has announced that the device will be discontinued, and a lifetime-buy period is in effect.

**NRND:** Not recommended for new designs. Device is in production to support existing customers, but TI does not recommend using this part in a new design.

**PREVIEW:** Device has been announced but is not in production. Samples may or may not be available.

**OBSOLETE:** TI has discontinued the production of the device.

(2) Eco Plan - The planned eco-friendly classification: Pb-Free (RoHS), Pb-Free (RoHS Exempt), or Green (RoHS & no Sb/Br) - please check <http://www.ti.com/productcontent> for the latest availability information and additional product content details.

**TBD:** The Pb-Free/Green conversion plan has not been defined.

**Pb-Free (RoHS):** TI's terms "Lead-Free" or "Pb-Free" mean semiconductor products that are compatible with the current RoHS requirements for all 6 substances, including the requirement that lead not exceed 0.1% by weight in homogeneous materials. Where designed to be soldered at high temperatures, TI Pb-Free products are suitable for use in specified lead-free processes.

**Pb-Free (RoHS Exempt):** This component has a RoHS exemption for either 1) lead-based flip-chip solder bumps used between the die and package, or 2) lead-based die adhesive used between the die and leadframe. The component is otherwise considered Pb-Free (RoHS compatible) as defined above.

**Green (RoHS & no Sb/Br):** TI defines "Green" to mean Pb-Free (RoHS compatible), and free of Bromine (Br) and Antimony (Sb) based flame retardants (Br or Sb do not exceed 0.1% by weight in homogeneous material)

(3) MSL, Peak Temp. -- The Moisture Sensitivity Level rating according to the JEDEC industry standard classifications, and peak solder temperature.

(4) Multiple Top-Side Markings will be inside parentheses. Only one Top-Side Marking contained in parentheses and separated by a "~" will appear on a device. If a line is indented then it is a continuation of the previous line and the two combined represent the entire Top-Side Marking for that device.

**Important Information and Disclaimer:** The information provided on this page represents TI's knowledge and belief as of the date that it is provided. TI bases its knowledge and belief on information provided by third parties, and makes no representation or warranty as to the accuracy of such information. Efforts are underway to better integrate information from third parties. TI has taken and continues to take reasonable steps to provide representative and accurate information but may not have conducted destructive testing or chemical analysis on incoming materials and chemicals. TI and TI suppliers consider certain information to be proprietary, and thus CAS numbers and other limited information may not be available for release.

In no event shall TI's liability arising out of such information exceed the total purchase price of the TI part(s) at issue in this document sold by TI to Customer on an annual basis.

## TAPE AND REEL INFORMATION

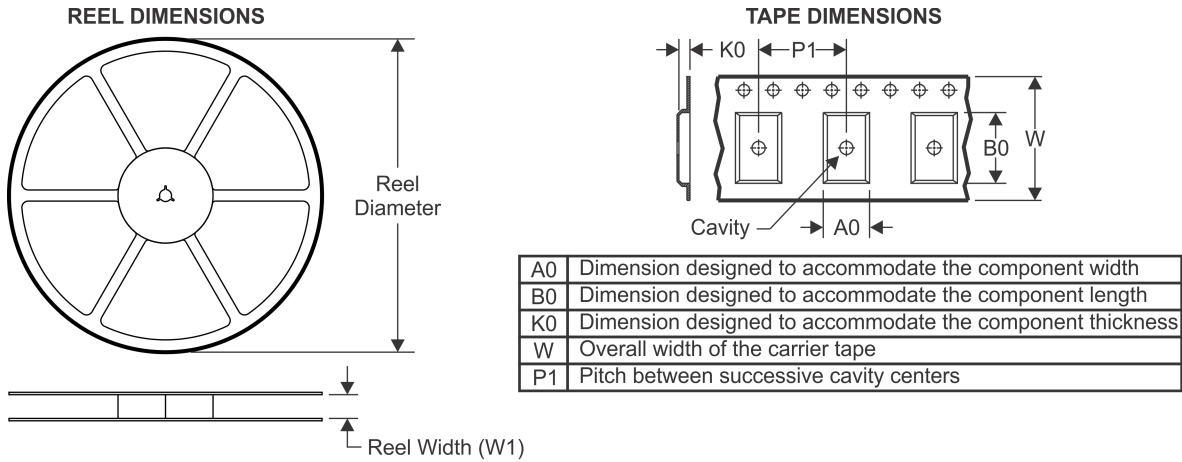

### QUADRANT ASSIGNMENTS FOR PIN 1 ORIENTATION IN TAPE

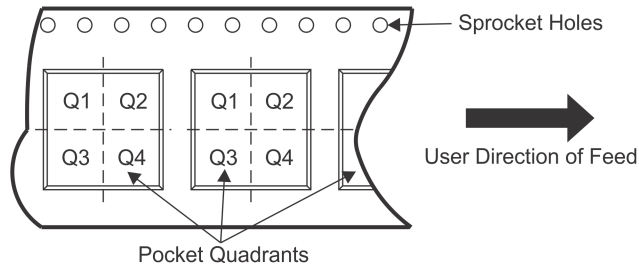

\*All dimensions are nominal

Device	Package Type	Package Drawing	Pins	SPQ	Reel Diameter (mm)	Reel Width W1 (mm)	A0 (mm)	B0 (mm)	K0 (mm)	P1 (mm)	W (mm)	Pin1 Quadrant
UCC25710DWR	SOIC	DW	20	2000	330.0	24.4	10.8	13.3	2.7	12.0	24.0	Q1

TAPE AND REEL BOX DIMENSIONS



\*All dimensions are nominal

Device	Package Type	Package Drawing	Pins	SPQ	Length (mm)	Width (mm)	Height (mm)
UCC25710DWR	SOIC	DW	20	2000	367.0	367.0	45.0

DW (R-PDSO-G20)

PLASTIC SMALL OUTLINE

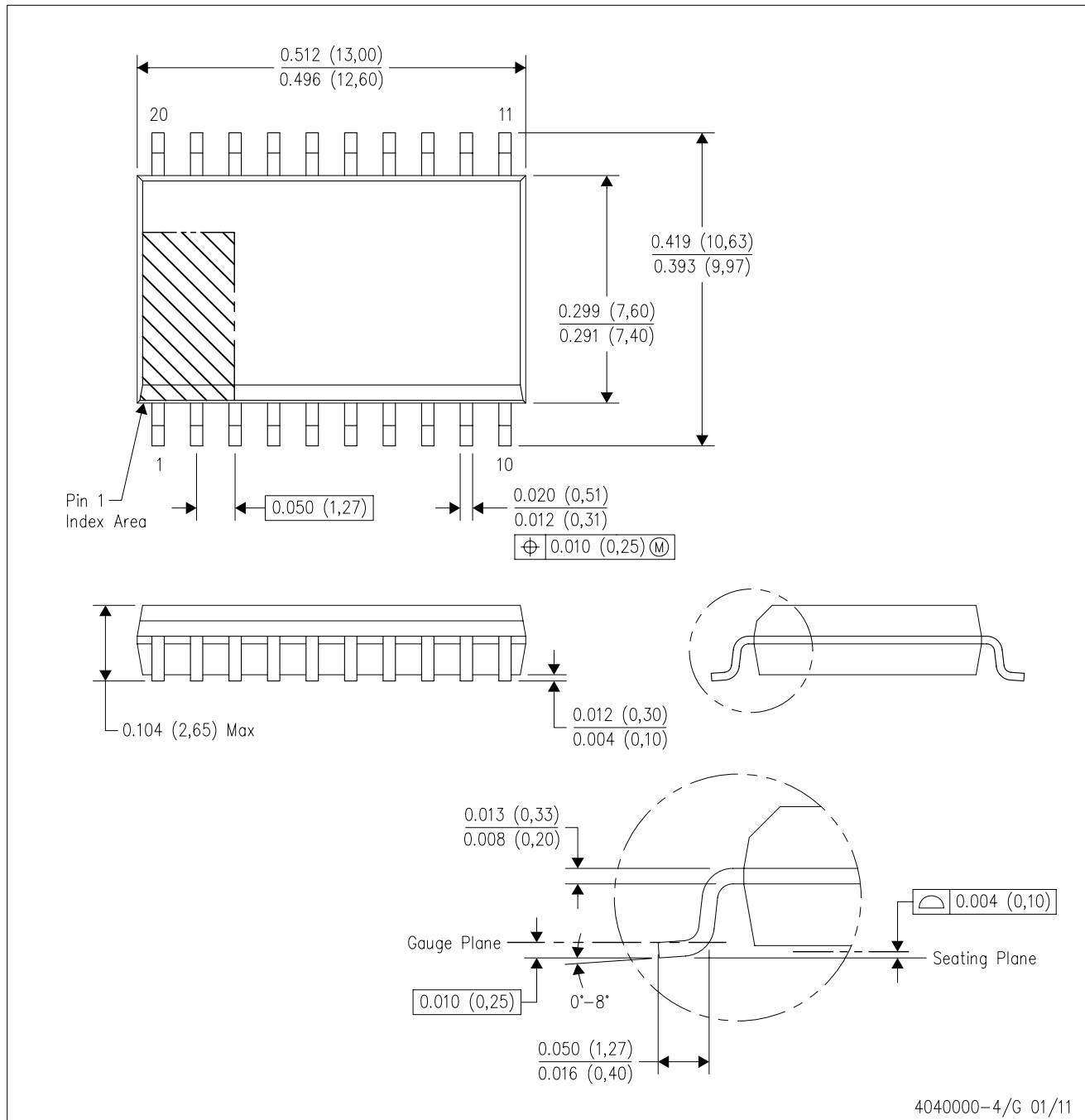

- NOTES:
- A. All linear dimensions are in inches (millimeters). Dimensioning and tolerancing per ASME Y14.5M-1994.
  - B. This drawing is subject to change without notice.
  - C. Body dimensions do not include mold flash or protrusion not to exceed 0.006 (0,15).
  - D. Falls within JEDEC MS-013 variation AC.

DW (R-PDSO-G20)

PLASTIC SMALL OUTLINE

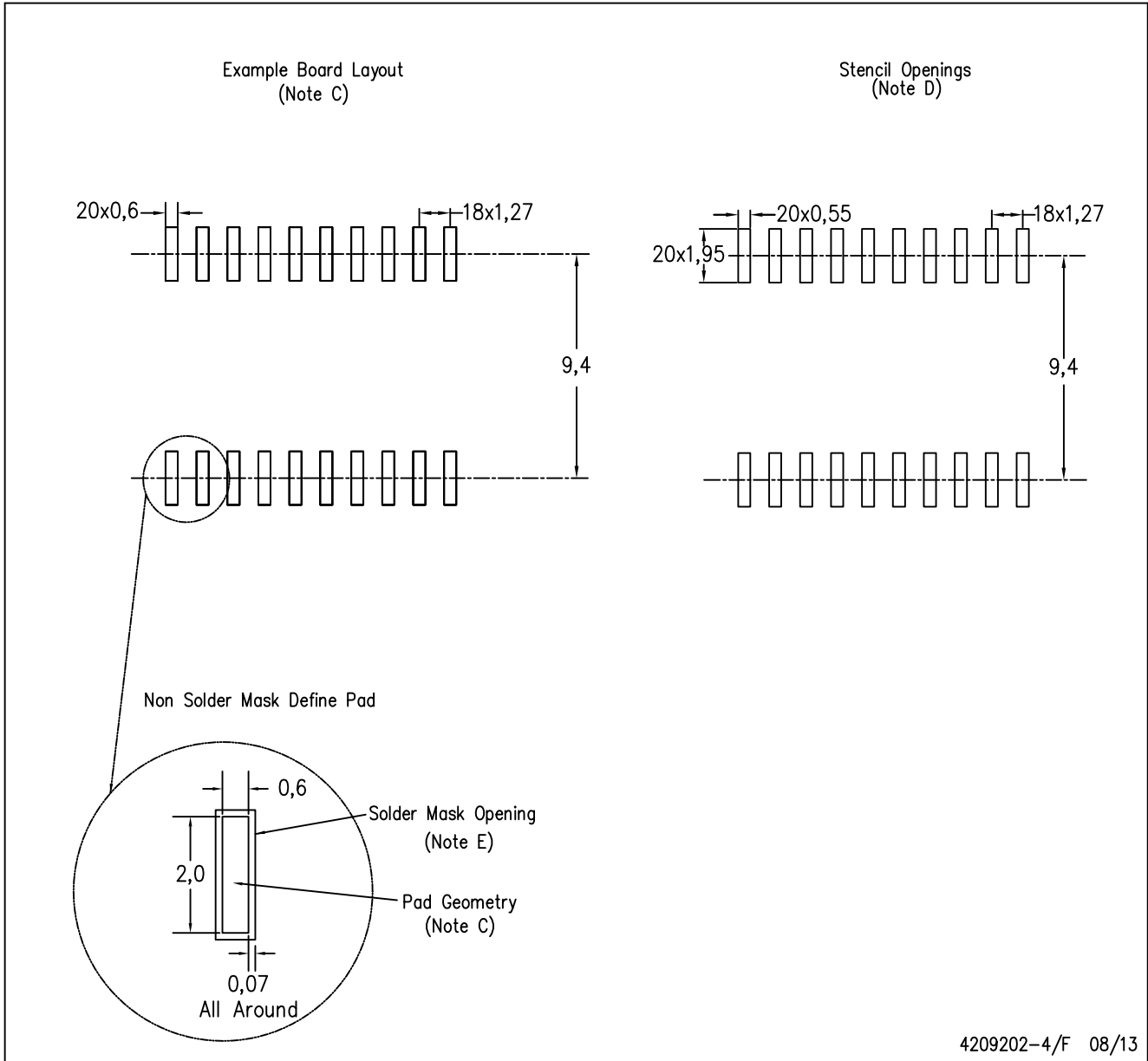

4209202-4/F 08/13

- NOTES:
- A. All linear dimensions are in millimeters.
  - B. This drawing is subject to change without notice.
  - C. Refer to IPC7351 for alternate board design.
  - D. Laser cutting apertures with trapezoidal walls and also rounding corners will offer better paste release. Customers should contact their board assembly site for stencil design recommendations. Refer to IPC-7525
  - E. Customers should contact their board fabrication site for solder mask tolerances between and around signal pads.

## IMPORTANT NOTICE

Texas Instruments Incorporated and its subsidiaries (TI) reserve the right to make corrections, enhancements, improvements and other changes to its semiconductor products and services per JESD46, latest issue, and to discontinue any product or service per JESD48, latest issue. Buyers should obtain the latest relevant information before placing orders and should verify that such information is current and complete. All semiconductor products (also referred to herein as "components") are sold subject to TI's terms and conditions of sale supplied at the time of order acknowledgment.

TI warrants performance of its components to the specifications applicable at the time of sale, in accordance with the warranty in TI's terms and conditions of sale of semiconductor products. Testing and other quality control techniques are used to the extent TI deems necessary to support this warranty. Except where mandated by applicable law, testing of all parameters of each component is not necessarily performed.

TI assumes no liability for applications assistance or the design of Buyers' products. Buyers are responsible for their products and applications using TI components. To minimize the risks associated with Buyers' products and applications, Buyers should provide adequate design and operating safeguards.

TI does not warrant or represent that any license, either express or implied, is granted under any patent right, copyright, mask work right, or other intellectual property right relating to any combination, machine, or process in which TI components or services are used. Information published by TI regarding third-party products or services does not constitute a license to use such products or services or a warranty or endorsement thereof. Use of such information may require a license from a third party under the patents or other intellectual property of the third party, or a license from TI under the patents or other intellectual property of TI.

Reproduction of significant portions of TI information in TI data books or data sheets is permissible only if reproduction is without alteration and is accompanied by all associated warranties, conditions, limitations, and notices. TI is not responsible or liable for such altered documentation. Information of third parties may be subject to additional restrictions.

Resale of TI components or services with statements different from or beyond the parameters stated by TI for that component or service voids all express and any implied warranties for the associated TI component or service and is an unfair and deceptive business practice. TI is not responsible or liable for any such statements.

Buyer acknowledges and agrees that it is solely responsible for compliance with all legal, regulatory and safety-related requirements concerning its products, and any use of TI components in its applications, notwithstanding any applications-related information or support that may be provided by TI. Buyer represents and agrees that it has all the necessary expertise to create and implement safeguards which anticipate dangerous consequences of failures, monitor failures and their consequences, lessen the likelihood of failures that might cause harm and take appropriate remedial actions. Buyer will fully indemnify TI and its representatives against any damages arising out of the use of any TI components in safety-critical applications.

In some cases, TI components may be promoted specifically to facilitate safety-related applications. With such components, TI's goal is to help enable customers to design and create their own end-product solutions that meet applicable functional safety standards and requirements. Nonetheless, such components are subject to these terms.

No TI components are authorized for use in FDA Class III (or similar life-critical medical equipment) unless authorized officers of the parties have executed a special agreement specifically governing such use.

Only those TI components which TI has specifically designated as military grade or "enhanced plastic" are designed and intended for use in military/aerospace applications or environments. Buyer acknowledges and agrees that any military or aerospace use of TI components which have **not** been so designated is solely at the Buyer's risk, and that Buyer is solely responsible for compliance with all legal and regulatory requirements in connection with such use.

TI has specifically designated certain components as meeting ISO/TS16949 requirements, mainly for automotive use. In any case of use of non-designated products, TI will not be responsible for any failure to meet ISO/TS16949.

### Products

Audio	<a href="http://www.ti.com/audio">www.ti.com/audio</a>
Amplifiers	<a href="http://amplifier.ti.com">amplifier.ti.com</a>
Data Converters	<a href="http://dataconverter.ti.com">dataconverter.ti.com</a>
DLP® Products	<a href="http://www.dlp.com">www.dlp.com</a>
DSP	<a href="http://dsp.ti.com">dsp.ti.com</a>
Clocks and Timers	<a href="http://www.ti.com/clocks">www.ti.com/clocks</a>
Interface	<a href="http://interface.ti.com">interface.ti.com</a>
Logic	<a href="http://logic.ti.com">logic.ti.com</a>
Power Mgmt	<a href="http://power.ti.com">power.ti.com</a>
Microcontrollers	<a href="http://microcontroller.ti.com">microcontroller.ti.com</a>
RFID	<a href="http://www.ti-rfid.com">www.ti-rfid.com</a>
OMAP Applications Processors	<a href="http://www.ti.com/omap">www.ti.com/omap</a>
Wireless Connectivity	<a href="http://www.ti.com/wirelessconnectivity">www.ti.com/wirelessconnectivity</a>

### Applications

Automotive and Transportation	<a href="http://www.ti.com/automotive">www.ti.com/automotive</a>
Communications and Telecom	<a href="http://www.ti.com/communications">www.ti.com/communications</a>
Computers and Peripherals	<a href="http://www.ti.com/computers">www.ti.com/computers</a>
Consumer Electronics	<a href="http://www.ti.com/consumer-apps">www.ti.com/consumer-apps</a>
Energy and Lighting	<a href="http://www.ti.com/energy">www.ti.com/energy</a>
Industrial	<a href="http://www.ti.com/industrial">www.ti.com/industrial</a>
Medical	<a href="http://www.ti.com/medical">www.ti.com/medical</a>
Security	<a href="http://www.ti.com/security">www.ti.com/security</a>
Space, Avionics and Defense	<a href="http://www.ti.com/space-avionics-defense">www.ti.com/space-avionics-defense</a>
Video and Imaging	<a href="http://www.ti.com/video">www.ti.com/video</a>

### TI E2E Community

[e2e.ti.com](http://e2e.ti.com)