

# Source Ringer Controller

## FEATURES

- Provides Control for Flyback Based Four Quadrant Amplifier Topology
- Onboard Sine Wave Reference with Low THD
- Selectable Ringing Frequency for Different Phone Systems (20Hz, 25Hz and 50Hz)
- Programmable Output Amplitude and DC Offset
- DC Current Limiting for Short Circuit Protection
- Secondary Side Voltage Mode Control
- Operates from a Single 5V Supply

## DESCRIPTION

The UCC3750 Source Ringer Controller provides a complete control and drive solution for a four quadrant flyback-based ring generator circuit. The IC controls a primary side switch, which is modulated when power transfer is taking place from input to output. It also controls two secondary switches which act as synchronous rectifier switches during positive power flow. These switches are pulse-width-modulated when the power is being delivered back to the source.

The UCC3750 has an onboard sine wave reference with programmable frequencies of 20Hz, 25Hz and 50Hz. The reference is derived from a high-frequency (32kHz) crystal connected externally. Two frequency-select pins control an internal divider to give a sinusoidal output at 20Hz, 25Hz or 50Hz. The ring generator can also be used at other frequencies by supplying externally generated sine-waves to the chip or by clocking the crystal input at a fixed multiple of the desired frequency.

Other features included in the UCC3750 are programmable DC current limit (with buffer amplifier), a charge-pump circuit for gate drive voltage, internal 3V and 7.5V references, a triangular clock oscillator and a buffer amplifier for adding programmable DC offset to the output voltage. The UCC3750 also provides an uncommitted amplifier (AMP) for other signal processing requirements.

## TYPICAL APPLICATION

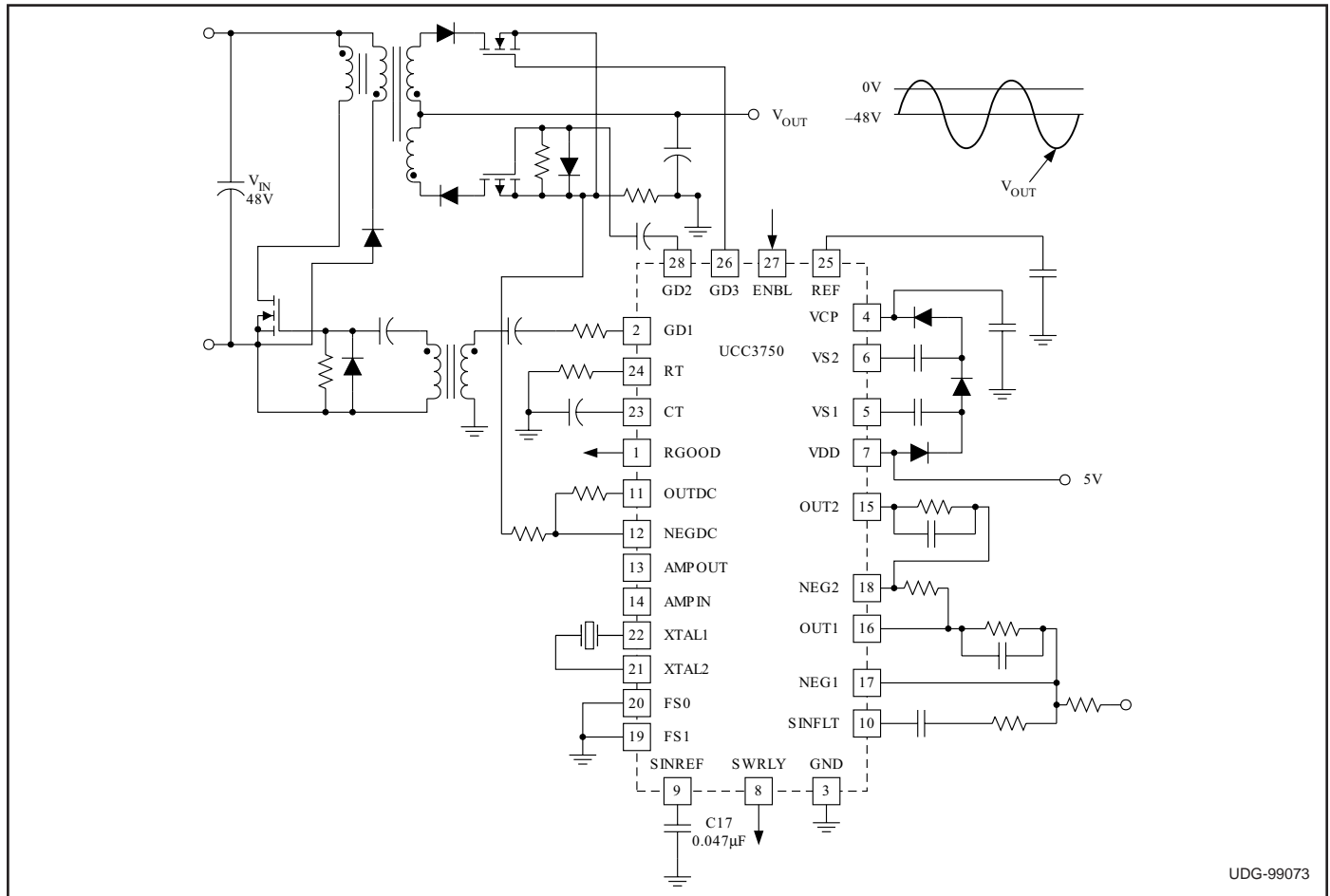

### ABSOLUTE MAXIMUM RATINGS

Input Supply Voltage	
VDD	7.5V
Maximum Forced Voltage	
VCP	-0.3V to 13.2V
VS1, VS2	-0.3V to 5V
OUT1, OUT2, AMPOUT, OUTDC	
Maximum Forced Voltage	-0.3V to 7.5V
Maximum Forced Current	Internally Limited
NEG1, NEG2, AMPIN, NEGDC	
Maximum Forced Voltage	-0.3V to 7.5V
SINREF, SINFLT	
Maximum Forced Voltage	-0.3V to 7.5V
Logic Inputs	
Maximum Forced Voltage	-0.3V to 7.5V
Reference Output Current (REF)	Internally Limited
Output Current (GD1, GD2, GD3)	
Pulsed	1.5A
Storage Temperature	-65°C to +150°C
Junction Temperature	-55°C to +150°C
Lead Temperature (Soldering, 10 Sec.)	+300°C

Unless otherwise indicated, voltages are reference to ground and currents are positive into, negative out of the specified terminal. Pulsed is defined as a less than 10% duty cycle with a maximum duration of 500ns. Consult Packaging Section of Databook for thermal limitations and considerations of packages.

### CONNECTION DIAGRAM

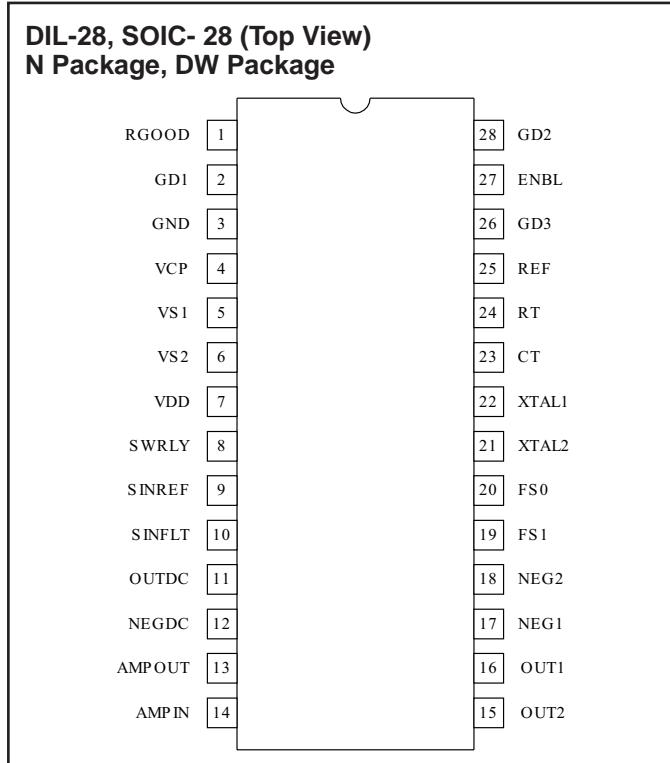

**ELECTRICAL CHARACTERISTICS:** Unless otherwise stated, these specifications apply for  $T_A = 0^\circ\text{C}$  to  $70^\circ\text{C}$  for the UCC3750,  $-40^\circ\text{C}$  to  $+85^\circ\text{C}$  for the UCC2750,  $R_T = 14\text{k}$ ,  $C_T = 470\text{pF}$ ,  $C_{REF} = 0.1\mu\text{F}$ ,  $FS_0 = 0$ ,  $FS_1 = 0$ ,  $V_{DD} = 5\text{V}$ .  $T_A = T_J$ .

PARAMETER	TEST CONDITIONS	MIN	TYP	MAX	UNITS
<b>VDD Supply</b>					
Supply Current - Active	With 12V Supplied to $V_{CP}$ and Charge Pump Disabled		0.5	1	mA
<b>Internal Reference w/External Bypass</b>					
Output Voltage (REF)		7.3	7.55	7.8	V
Load Regulation	$I_{REF} = 0\text{mA} - 2\text{mA}$		30	60	mV
Line Regulation	$V_{CP} = 10\text{V}$ to $13\text{V}$ , $I_{REF} = 1\text{mA}$		3	15	mV
<b>Amplifier</b>					
Input Voltage	Error, DC Offset and Amp Amplifiers	2.9	3	3.1	V
	DC Limit Amplifier	0.7125	0.75	0.7875	V
Input Bias Current			15	100	nA
AVOL	$V_{OUT} = 2\text{V}$ to $4\text{V}$		70		dB
VOH	Source $100\mu\text{A}$	5.35	6	7.0	V
VOL	Sink $100\mu\text{A}$		0.2	0.65	V
Short Circuit Current	$V_{IN} = 0\text{V}$ and $5\text{V}$ with $V_{OUT} = 0\text{V}$ and $5\text{V}$	0.5	2	3	mA
<b>Sine Reference</b>					
Accuracy	$T_J = 25^\circ\text{C}$ , Program Frequency–Reference Frequency	-1	0	1	Hz
Total Harmonic Distortion	(Note 1)			2	%
Amplitude	Peak	0.475	0.5	0.525	V
Offset		2.85	3.0	3.15	V

**ELECTRICAL CHARACTERISTICS:** Unless otherwise stated, these specifications apply for  $T_A = 0^\circ\text{C}$  to  $70^\circ\text{C}$  for the UCC3750,  $-40^\circ\text{C}$  to  $+85^\circ\text{C}$  for the UCC2750,  $R_T = 14\text{k}$ ,  $C_T = 470\text{pF}$ ,  $C_{REF} = 0.1\mu\text{F}$ ,  $FS0 = 0$ ,  $FS1 = 0$ ,  $V_{DD} = 5\text{V}$ .  $T_A = T_J$ .

PARAMETER	TEST CONDITIONS	MIN	TYP	MAX	UNITS
<b>Oscillator</b>					
Accuracy		108	128	148	kHz
Peak Voltage		4.6	4.75	4.9	V
Valley Voltage		2.9	3.05	3.2	V
<b>Charge Pump</b>					
Switch Pull Up Resistance (VS1, VS2)			10	30	$\Omega$
Switch Pull Down Resistance (VS1, VS2)			10	30	$\Omega$
Output Voltage (VCP)	$V_{DD} = 5\text{V}$ , $I_{VCP} = 10\text{mA}$	11	12	14	V
<b>Output Drivers</b>					
Pull Up Resistance			9	15	$\Omega$
Pull Down Resistance			9	15	$\Omega$
Rise Time	$CL = 2.7\text{nF}$		50	100	ns
Fall Time	$CL = 2.7\text{nF}$		50	100	ns
<b>Current Limit</b>					
DC Limit Threshold Voltage Positive	$R5/R6 = 3$	0.4	0.5	0.6	V
DC Limit Threshold Voltage Negative	$R5/R6 = 3$	-0.6	-0.5	-0.4	V
<b>Duty Cycle</b>					
Maximum PWM Duty Cycle		48	50		%
Rectifier Duty Cycle			50		%

Note 1: Guaranteed by measuring the steps of the PWL Sine Wave.

STATE	% VCC	VALUE FOR REF = 7.5	STATE	% VCC	VALUE FOR REF = 7.5
0	0.3333	2.5	5	0.4255	3.191
1	0.3384	2.538	6	0.4471	3.353
2	0.3528	2.646	7	0.4616	3.462
3	0.3745	2.808	8	0.4666	3.5
4	0.4	3			

## PIN DESCRIPTIONS

**AMPIN:** Inverting input of the uncommitted amplifier.

**AMPOUT:** Output of the uncommitted amplifier.

**CT:** This pin programs the internal PWM oscillator frequency. Capacitor from CT to GND sets the charge and discharge time of the oscillator.

**ENBL:** Logic input which enables the outputs and the charge pump when high. ENBL should be pulled low to turn the outputs off.

**FS0, FS1:** Frequency select pins for the internal sine-wave generator. Table 1 provides the SINREF frequencies as a function of FS0 and FS1 when a 32kHz crystal is used at the crystal inputs (XTAL1, XTAL2). Other proportional frequencies can be obtained with a different crystal. Inputs FS0 and FS1 are TTL compatible.

Table I. Frequency selection table  
(for 32kHz crystal).

FS0	FS1	SINREF (Hz)
0	0	20
1	0	25
0	1	50
1	1	High Impedance

**GD1:** Output driver that controls the primary side switch in a flyback converter through a gate drive transformer. The output signal on this pin is PWM during positive power transfer modes and zero during negative power transfer modes.

## PIN DESCRIPTIONS (cont.)

**GD2:** Output driver that controls the p-channel secondary side switch in the flyback converter. The output signal on this pin is PWM during mode 4 (Fig. 2) when the reference signal is negative and power is being returned to the input. This pin functions as a synchronous rectifier output during mode 1 with positive reference signal and positive power transfer. This output is logically inverted to provide the correct polarity drive signal for a p-channel switch.

**GD3:** Output driver that controls the n-channel secondary side switch in the flyback converter. The output signal on this pin is PWM during mode 2 (Fig. 2) when the reference signal is positive and power is being returned to the input. This pin functions as a synchronous rectifier output during mode 3 with a negative reference signal and positive power transfer.

**GND:** Reference point for the internal reference and all thresholds. Also provides the signal return path for all other pins.

**NEG1:** Inverting input of the buffer amplifier that acts as a summing junction for the DC (battery) offset voltage and sine wave reference.

**NEG2:** Inverting input of the error amplifier where the ringer output voltage and the reference signal with the desired offset are applied with a weighted sum. Feedback compensation is connected between NEG2 and OUT2.

**NEGDC:** Inverting input of the amplifier used for DC current limiting.

**OUT1:** Output of the buffer amplifier that provides scaling and filtering for the reference signal before feeding it into the error amplifier. This output is also used internally to select the PWM mode for the flyback converter.

**OUT2:** Output of the error amplifier. Used to connect compensation components. This output's absolute value determines the duty cycle of the PWM pulse. The polarity of this signal also determines the PWM mode.

**OUTDC:** Output of the DC current limit amplifier. The DC current limit is activated when this pin is above 4.5V or below 1.5V.

**REF:** Internal 7.5V reference. For best results, bypass to GND with a ceramic capacitor ( $>0.1\mu\text{F}$ ).

**RGOOD:** Logic output that indicates that the error amplifier output is within range ( $0 < D < 0.5$ ). This pin can source up to 0.5mA of current.

**RT:** Resistor from RT to GND helps set the oscillator frequency. RT programs the charge and discharge currents of CT.

**SINFLT:** This signal is the buffered version of SINREF. This signal is summed with the DC offset level with appropriate scaling.

**SINREF:** This pin is the output of the sine-wave reference generator. It has a high output impedance ( $\approx 25\text{k}\Omega$ ). A  $0.01\mu\text{F}$  capacitor to GND is recommended to provide smoothing of the sinewave. When FS0 and FS1 are both set high, the sine reference generator is disabled allowing this pin to accept an external sinewave input.

**SWRLY:** Logic output that leads the battery offset crossings (by typically 5ms) to allow "zero voltage" relay switching. This pin can typically source  $250\mu\text{A}$ .

**XTAL1:** Crystal connection for external crystal. This pin can be also used to clock the internal sine wave generator when XTAL2 is connected to VDD/2.

**XTAL2:** Crystal connection for external crystal.

**VCP:** External connection for charge pump storage capacitor. A capacitance  $\geq 2.2\text{mF}$  is recommended for low charge pump output ripple. The voltage at this pin is used by the output drivers for gate drive voltages. Alternatively, a regulated gate drive voltage ( $>10\text{V}$ ) can be connected at this pin while leaving the charge pump circuit at nodes VS1, VS2 disconnected.

**VDD:** External supply input used to bias internal logic functions. Typically a regulated 5V supply is connected between this pin and GND. It also is the input voltage for the voltage tripler circuit to generate the gate drive voltage.

**VS1, VS2:** Voltage switches for the voltage tripler (charge pump circuit). They provide different voltage levels to external capacitors in order to pump up the voltage from VDD to VCP.

**DETAILED BLOCK DIAGRAM**

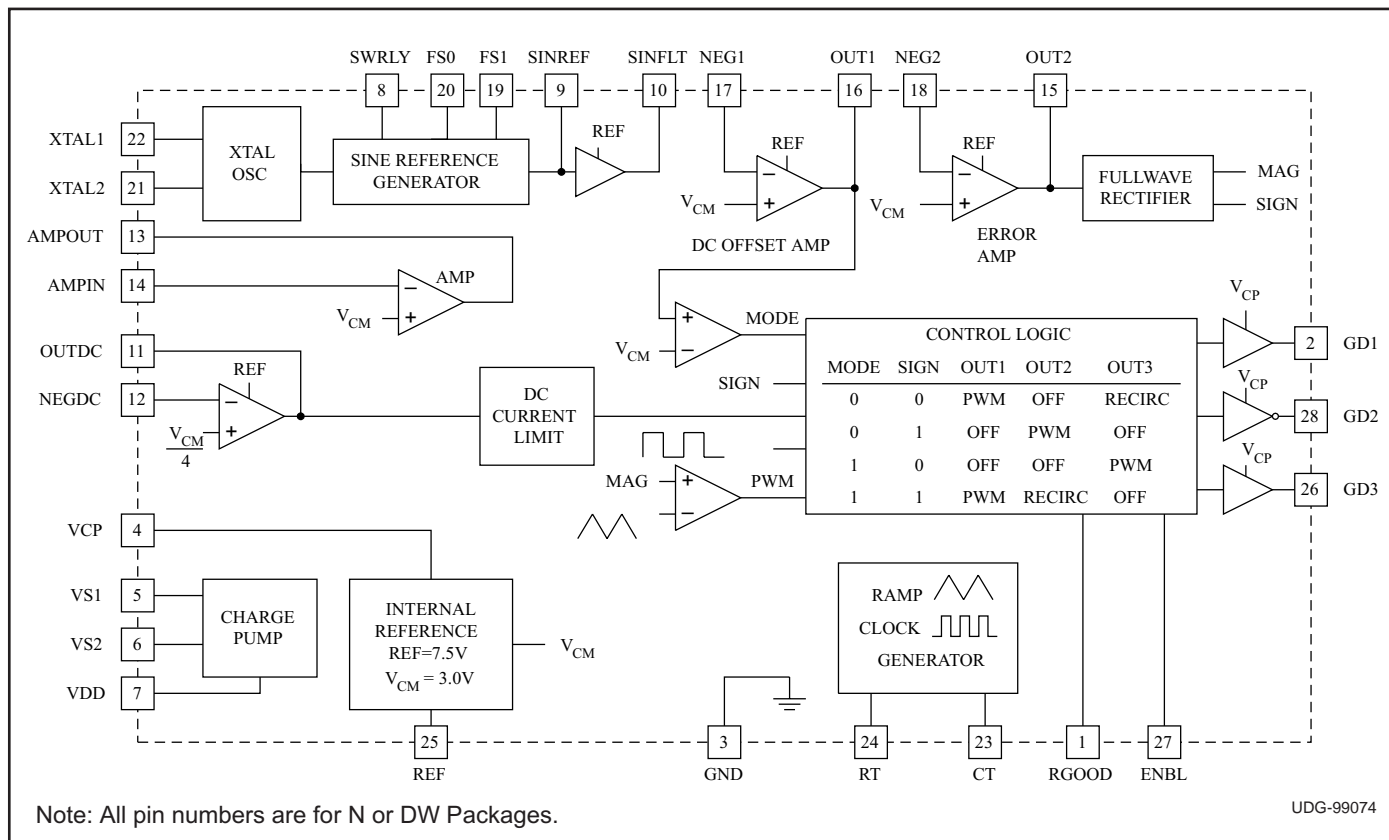

**APPLICATION INFORMATION**

The UCC3750 provides complete control and protection functions for a four quadrant flyback converter used to generate ring signals for telephone circuits. A typical application circuit for a 15 REN ring generator is shown in Fig. 1.

As shown, the flyback converter takes a DC input (typically 48V) and provides an isolated output with a programmable frequency (and amplitude) AC signal superimposed on a programmable DC offset. The power path consists of a primary side PWM switch Q1, primary return rectifier DR1, a 4-winding transformer T1, output rectifiers DR2 and DR3, synchronous/PWM switches Q2 and Q3, and output filter CF. Resistor RSENSE provides the output current sensing for protection circuits.

Different operating modes of the converter are depicted in Table 2. Fig. 2 shows the output voltage and current waveforms for a purely capacitive load and identifies the four operating modes. Fig. 3 shows the PWM waveforms for the circuit and Fig. 4a - 4d show the equivalent circuits under the operating modes. The addition of Q2, Q3 and primary diode facilitates true four quadrant operation where both the output voltage and power transfer can be bi-directional. Mode 1 is similar to the commonly used

DC-DC converter operation where Q1 is modulated with the PWM signal and rectification is provided through the Q2, DR2 path to provide a positive output proportional to the increasing, positive reference voltage. The pulse-width is controlled by the error amplifier output to increase or decrease the output as dictated by the reference. The maximum duty cycle is limited to 50% to prevent DR1 from turning on prior to Q2/DR2.

In mode 2, the reference begins to decrease, necessitating that the power transfer back to the input. For this mode, switch Q3 needs to be modulated while DR1 acts as the rectifier back to the input. The UCC3750 has mode decoding circuitry which automatically directs the PWM signal to Q3 and turns off Q1.

Table II. Operating modes.

Mode	Reference Polarity	Power Flow	E.A. Output	Source (PWM) Switch	Rectifier Switch
1	+	+	-	Q1	Q2
2	+	-	+	Q3	(D1)
3	-	+	+	Q1	Q3
4	-	-	-	Q2	(D1)



**APPLICATION INFORMATION (cont.)**

When the reference signal goes from positive to negative, a transition is made from mode 2 to mode 3. In mode 3, the converter once again acts as a DC-DC flyback converter (with negative output). Similar to mode 1, Q1 is controlled by the PWM output, however, the rectifying path is now through Q3/DR3 as the output polarity is reversed. At the mode boundaries, there could be some distortion which won't affect the THD too much as it is near zero crossings. Finally, as the reference signal

starts increasing towards zero, the direction of power transfer is again reversed and Q2 is PWMed in mode 4.

It should be noted that in modes 2 and 3 when the reference is decreasing, the phase of the feedback path is inverted compared to the other two modes. Traditional PWM methods will result in instability due to this characteristic. The UCC3750 separates the error signal magnitude and polarity and determines the correct PWM signal based on a separate mode determination circuit.

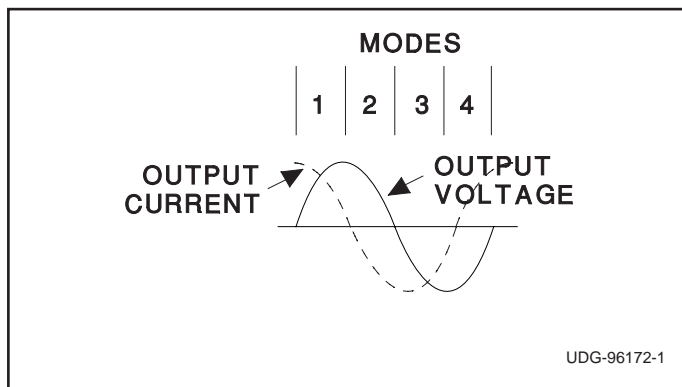

Figure 2. Operating modes.

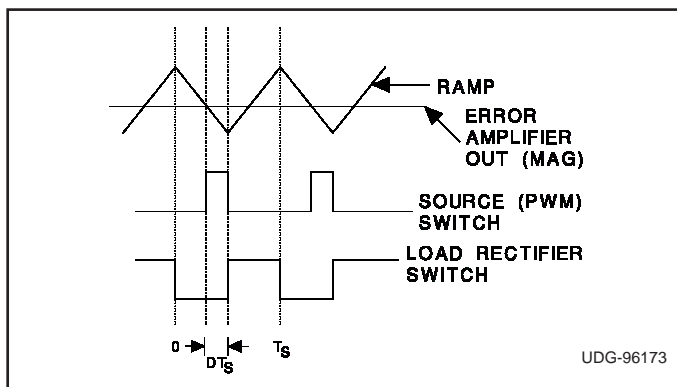

Figure 3. Circuit waveforms.

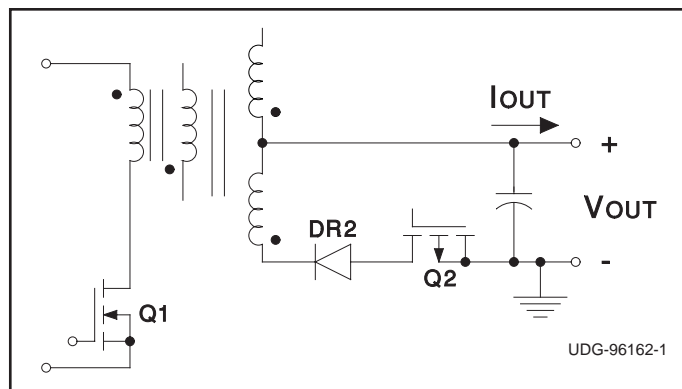

Figure 4a. Mode 1: Forward power transfer, positive output.

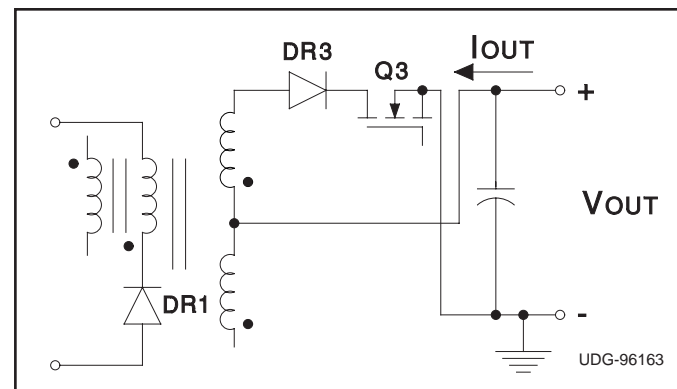

Figure 4b. Mode 2: Reverse power transfer, positive output.

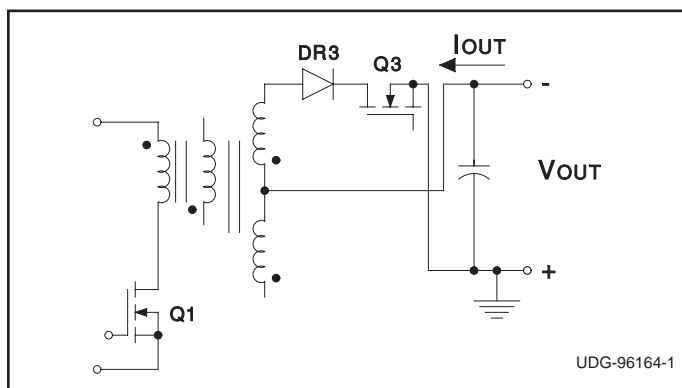

Figure 4c. Mode 3: Forward power transfer, negative output.

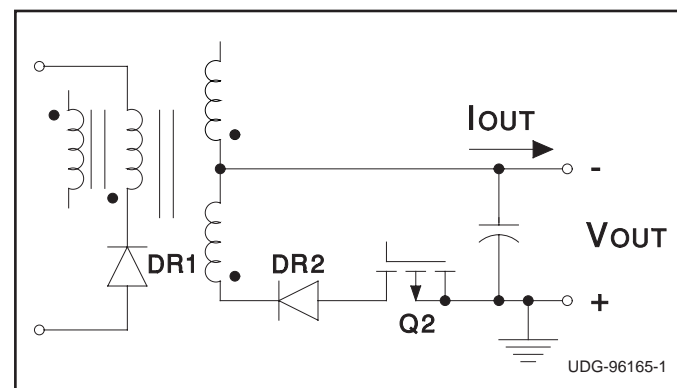

Figure 4d. Mode 4: Reverse power transfer, negative output.

**APPLICATION INFORMATION (cont.)**

**Sine Reference Generator**

The IC has a versatile low frequency sinewave reference generator with low harmonic distortion and good frequency accuracy. In its intended mode as shown in Fig. 5, the reference generator will take an input from a 32kHz crystal (connected between XTAL1 and XTAL2) and generate a sine-wave at 20Hz, 25Hz or 50Hz based on the programming of pins FS0 and FS1 (See Table 2). If the crystal frequency is changed, the output frequencies will be appropriately shifted. C-2 type Quartz crystals (Epson makes available through DigiKey) are recommended for this application. If the frequency accuracy is not a major concern, the more common and less expensive clock crystal (C-type) at 32.768kHz can be used with a minor output frequency offset (20.5Hz instead of 20Hz). Additionally, the XTAL1 input can be clocked at a desired frequency to get a different set of output frequencies at the sine-wave output (with divide ratios of 1600, 1280 and 640). The sine-wave output is centered around an internal reference of 3V. A capacitor from SINREF to GND helps provide smoothing of the sine wave reference. Recommended value is at least 0.01μF and maximum of 0.1μF. When FS0 and FS1 are both 1 (high), the sine reference is disabled and external sine-wave can be fed into the SINREF pin. This signal should have the same DC offset as the internal sine-wave (3V).

**Reference and Error Amplifier**

The recommended circuit connections for these circuits are shown in Fig. 6. The sine-wave is added to a DC offset to create the composite reference signal for the error amplifier. The DC reference can vary over a wide range. For pure AC outputs it is zero, while in many common applications, it is the talk battery voltage (-48V). The UCC3750 accomplishes this task by summing the two signals weighted by resistors R14 and R15. The output of AMP1 also helps determine the mode of the circuit.

Referring to Fig. 6, the output of AMP1 is given by :

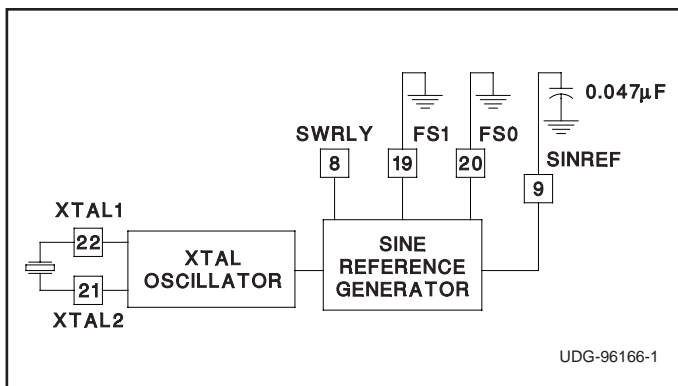

Figure 5. Sine-wave generator.

$$V_{OUT1} = \left(1 + \frac{R_{13}}{R_{14}} + \frac{R_{13}}{R_{26}}\right) \cdot V_{CM} - \frac{R_{13}}{R_{26}} \cdot REF - \frac{R_{13}}{R_{14}} \cdot V_B - \frac{R_{13}}{R_{15}} \cdot V_{AC} \quad (1)$$

In order to nullify the effect of  $V_{CM}$  on this value, the ratio of R26 to R14 should be made 1.5. With this ratio, the equation becomes:

$$V_{OUT1} = V_{CM} - \frac{R_{13}}{R_{14}} \cdot V_B - \frac{R_{13}}{R_{15}} \cdot V_{AC} \quad (2)$$

$V_{OUT1}$  is the reference voltage that the second amplifier (AMP2) uses to program the output voltage. Assuming that Z4 is high DC impedance, the output voltage is derived by summing the currents into pin 18. The output is given as:

$$V_O = \left(1 + \frac{R_{10}}{R_{27}} + \frac{R_{10}}{R_{12}}\right) \cdot V_{CM} - \frac{R_{10}}{R_{27}} \cdot REF - \frac{R_{10}}{R_{12}} \cdot V_{OUT1} \quad (3)$$

Again, if the ratio of R27 to R10 is made 1.5, the effect of  $V_{CM}$  is nullified and the output voltage becomes (after substituting for  $V_{OUT1}$ ):

$$V_O = \frac{R_{10} \cdot R_{13}}{R_{12} \cdot R_{14}} \cdot V_B + \frac{R_{10} \cdot R_{13}}{R_{12} \cdot R_{15}} \cdot V_{AC} \quad (4)$$

From equation 4, it can be seen that if the output voltage DC value has to track  $V_B$  directly, the following condition should be forced:

$$R_{10} \cdot R_{13} = R_{12} \cdot R_{14} \quad (5)$$

However, in some cases, this becomes impractical due to large AC gain required from  $V_{AC}$  to  $V_O$ . Only a small part of the gain can be accommodated in the first amplifier stage due to its output voltage limitations. As a result, the required resistance values become very high. This

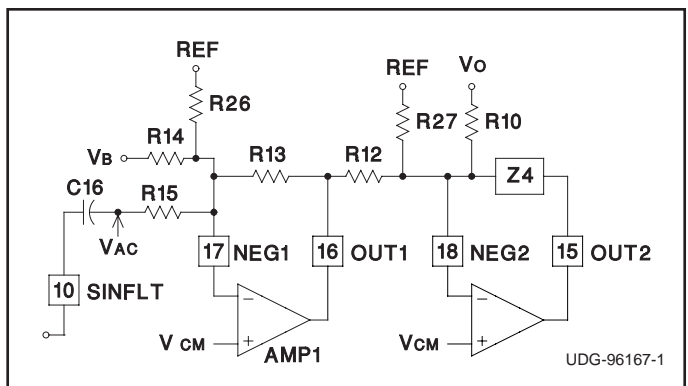

Figure 6. Error amplifier setup.

### APPLICATION INFORMATION (cont.)

problem is only manifested for high values of  $V_B$  (e.g. 48V) and can be alleviated by using a fraction of the required DC offset as the  $V_B$  input and regaining the offset with resistive ratios.

The error amplifier compares the reference signal with the output voltage by way of weighted sum at its inverting input. The error signal is further processed to separate its polarity and magnitude. An absolute value circuit (precision full-wave rectifier) is used to get the magnitude information. The polarity is used along with the reference signal polarity to determine the mode information. The absolute value circuit provides phase inversion when appropriate for modes 2 and 3 to maintain the correct loop gain polarity. While the output of the error amplifier swings around 3V, the full-wave rectifier output (MAG) converts it into a signal above 3V. This signal is compared to the oscillator ramp to generate the PWM output.

#### Oscillator and PWM Comparator

The UCC3750 has an internal oscillator capable of high frequency (>250kHz) operation. A resistor on the  $R_T$  pin programs the current that charges and discharges  $C_T$ , resulting in a triangular ramp waveform. Fig 7. shows the oscillator hook-up circuit. The ramp peak and valley are 4.75V and 3V respectively. The nominal frequency is given by:

$$f_{osc} = \frac{1}{1.17 \cdot R_T \cdot C_T}$$

The ramp waveform and the rectified output of the error amplifier are compared by the PWM comparator to generate the PWM signal. The PWM action is disabled on the positive slope of the ramp signal. Leading edge mod-

ulation turns on the PWM signal when the ramp signal falls below MAG on the falling slope and turns it off at the end of the clock cycle. This technique enables synchronized turn-on of the rectifier switches immediately after the PWM pulse is turned off. The triangular nature of the ramp ensures that the maximum duty cycle of the PWM output is 50%, providing inherent current limiting.

#### Control Logic and Outputs

The PWM signal is processed through control logic which takes into account the operating mode and output polarity to determine which output to modulate. The logic table for the outputs is given in Table 2. For example, assume that the reference signal is in the first quadrant (positive and increasing). The output will lag the reference by a certain delay and hence the error amp output will be positive, resulting in  $SIGN = 0$ . The logic table indicates that GD1 is modulated during this phase allowing power transfer to increase the output voltage to keep up with the reference. Increasing error (MAG) will result in larger duty cycle and enable the output to increase and catch up with the reference. If the output becomes higher than the reference (as is likely in the second quadrant when the reference is dropping), the  $SIGN$  becomes 1 and GD3 is modulated to decrease the output level by transferring power to the input. At the boundary of the first and second quadrant, there may be some switching back and forth between modes as the reference slope crosses through zero. Some of this switching can be eliminated by judicious selection of error amplifier filtering and compensation components. In the first quadrant, when PWM is applied to Q1, Q2 is turned on in the rectifier mode by the clock signal to allow the flyback transformer flux to

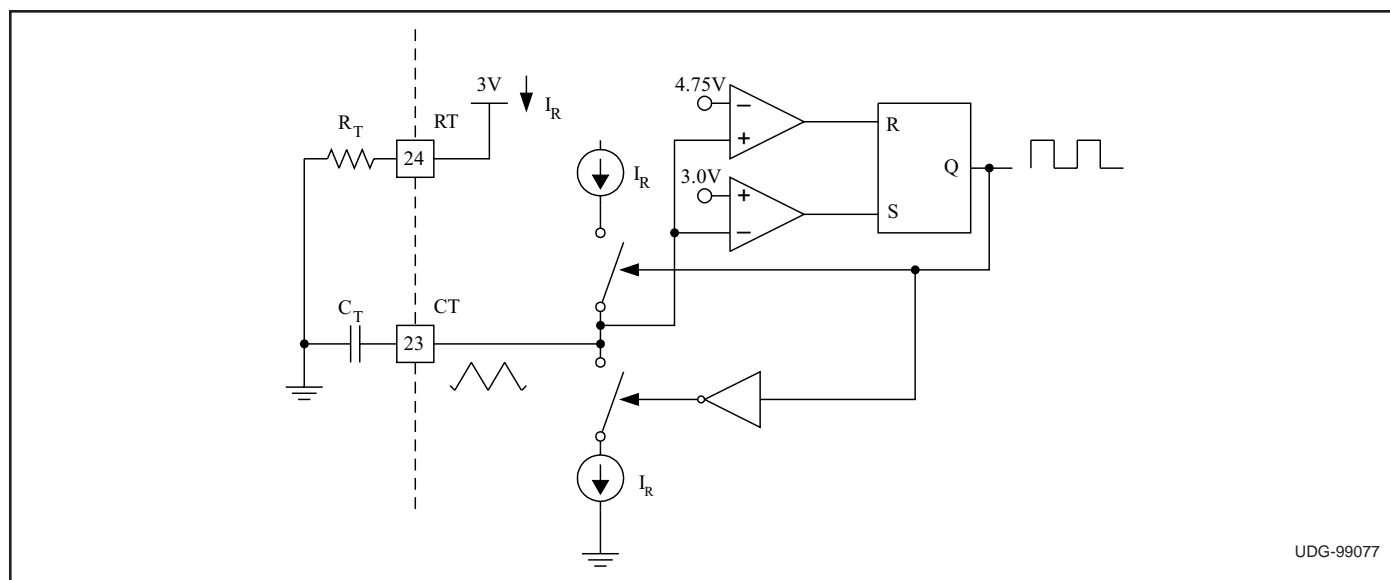

Figure 7. Oscillator setup.

APPLICATION INFORMATION (cont.)

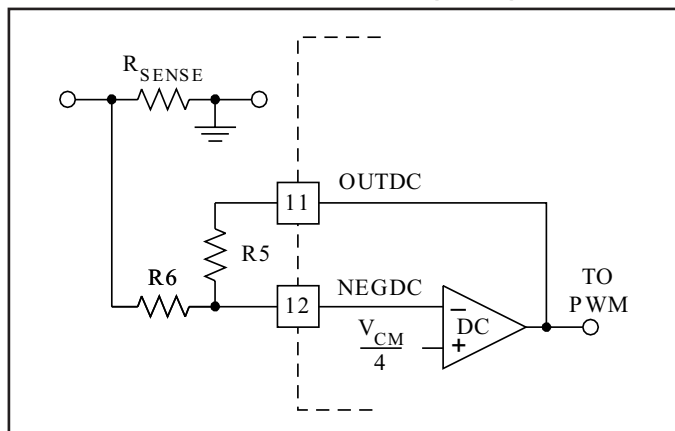

Figure 8. Current limiting.

reset (and to transfer power to the output). Operation in quadrants 3 and 4 is symmetrical to the first two quadrants with Q2 and Q3 interchanged. Note that the output signal for Q2 is logically inverted to allow for driving the p-channel switch. An n-channel switch can also be used for Q2, but the drive circuit must be transformer isolated and the polarity inverted. The outputs are designed for high peak current drive and low internal impedance. In isolated systems, GD1 must be coupled to Q1 using a gate-drive transformer.

**DC Current Limit**

The DC current limit function provides protection against short circuit conditions by limiting the maximum current level and shutting off the PWM function when the limit point is reached.

The DC limit is activated when DC out is below  $0.5 V_{CM}$  or above  $1.5 \cdot V_{CM}$ . The DC current limit can be programmed by setting:

$$\frac{R5}{R6} = 3.$$

With this ratio, a symmetric DC limit with thresholds of  $\pm 0.5V$  is obtained. For other ratios, the positive and negative voltage thresholds for current sense signal are given by:

$$V_{SENSE(POS)} = \frac{V_{CM}}{4} \cdot \left(1 - \frac{R6}{R5}\right)$$

$$V_{SENSE(NEG)} = \frac{V_{CM}}{4} \cdot \left(1 - \frac{5R6}{R5}\right)$$

Even though the DC current is typically sensed in the secondary, the current limit is applied to the active PWM switch at the time. For example, if Q1 is the PWM switch and DCLIM is activated, the UCC3750 will prevent turn-on for Q1 during the negative slope of the ramp (Fig. 2). The DC limit is functional on a cycle-by-cycle basis.

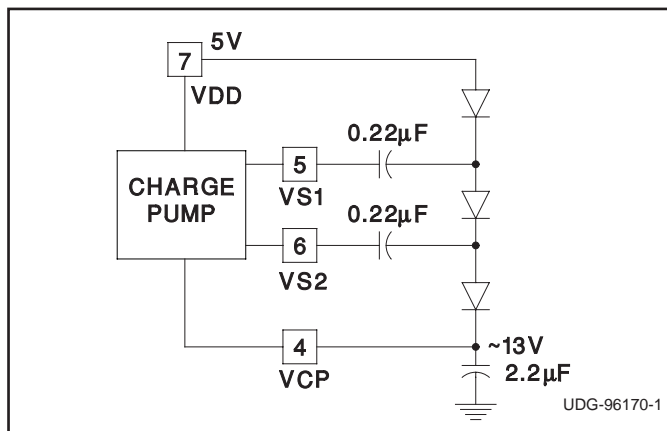

Figure 9. Charge pump circuits.

**Charge Pump and Reference**

The UCC3750 is designed to work on the secondary side of an isolated power supply. It requires a 5V power supply with respect to its GND pin to operate. Note that the GND pin of the IC is also the reference point of the ring signal that is generated by the converter. If the converter output is connected in series with any other voltage, it should be ensured that the available supply voltage is referenced to the converter output return. The IC along with its associated charge pump components shown in Fig. 9 generates all the other voltages the system requires. The UCC3750 typically requires about 5mA to operate without any loads on the drive outputs. The charge pump capacitor should be large enough to keep the VCP fairly constant when driving Q1-Q3 in the converter.

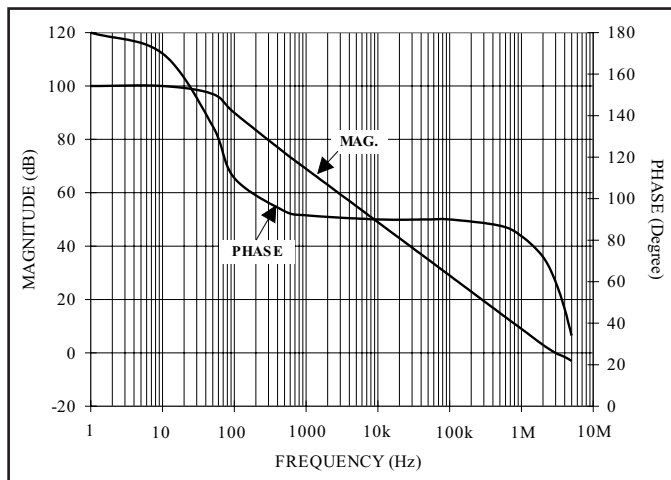

Figure 10. Frequency response to error amplifiers.

Table II. Revision History

Revision	Date	Comment
C	08/2005	Changed amplifier input bias current maximum limit from 600 nA to 100 nA and Typical from 500 nA to 15 nA.

## PACKAGING INFORMATION

Orderable Device	Status (1)	Package Type	Package Drawing	Pins	Package Qty	Eco Plan (2)	Lead/Ball Finish (6)	MSL Peak Temp (3)	Op Temp (°C)	Device Marking (4/5)	Samples
UCC2750DW	ACTIVE	SOIC	DW	28	20	Green (RoHS & no Sb/Br)	CU NIPDAU	Level-2-260C-1 YEAR	-40 to 85	UCC2750DW	<a href="#">Samples</a>
UCC3750DW	ACTIVE	SOIC	DW	28	20	Green (RoHS & no Sb/Br)	CU NIPDAU	Level-2-260C-1 YEAR	0 to 70	UCC3750DW	<a href="#">Samples</a>
UCC3750DWTR	ACTIVE	SOIC	DW	28	1000	Green (RoHS & no Sb/Br)	CU NIPDAU	Level-2-260C-1 YEAR	0 to 70	UCC3750DW	<a href="#">Samples</a>
UCC3750DWTRG4	ACTIVE	SOIC	DW	28	1000	Green (RoHS & no Sb/Br)	CU NIPDAU	Level-2-260C-1 YEAR	0 to 70	UCC3750DW	<a href="#">Samples</a>

(1) The marketing status values are defined as follows:

**ACTIVE:** Product device recommended for new designs.

**LIFEBUY:** TI has announced that the device will be discontinued, and a lifetime-buy period is in effect.

**NRND:** Not recommended for new designs. Device is in production to support existing customers, but TI does not recommend using this part in a new design.

**PREVIEW:** Device has been announced but is not in production. Samples may or may not be available.

**OBSELETE:** TI has discontinued the production of the device.

(2) Eco Plan - The planned eco-friendly classification: Pb-Free (RoHS), Pb-Free (RoHS Exempt), or Green (RoHS & no Sb/Br) - please check <http://www.ti.com/productcontent> for the latest availability information and additional product content details.

**TBD:** The Pb-Free/Green conversion plan has not been defined.

**Pb-Free (RoHS):** TI's terms "Lead-Free" or "Pb-Free" mean semiconductor products that are compatible with the current RoHS requirements for all 6 substances, including the requirement that lead not exceed 0.1% by weight in homogeneous materials. Where designed to be soldered at high temperatures, TI Pb-Free products are suitable for use in specified lead-free processes.

**Pb-Free (RoHS Exempt):** This component has a RoHS exemption for either 1) lead-based flip-chip solder bumps used between the die and package, or 2) lead-based die adhesive used between the die and leadframe. The component is otherwise considered Pb-Free (RoHS compatible) as defined above.

**Green (RoHS & no Sb/Br):** TI defines "Green" to mean Pb-Free (RoHS compatible), and free of Bromine (Br) and Antimony (Sb) based flame retardants (Br or Sb do not exceed 0.1% by weight in homogeneous material)

(3) MSL, Peak Temp. - The Moisture Sensitivity Level rating according to the JEDEC industry standard classifications, and peak solder temperature.

(4) There may be additional marking, which relates to the logo, the lot trace code information, or the environmental category on the device.

(5) Multiple Device Markings will be inside parentheses. Only one Device Marking contained in parentheses and separated by a "~" will appear on a device. If a line is indented then it is a continuation of the previous line and the two combined represent the entire Device Marking for that device.

(6) Lead/Ball Finish - Orderable Devices may have multiple material finish options. Finish options are separated by a vertical ruled line. Lead/Ball Finish values may wrap to two lines if the finish value exceeds the maximum column width.

**Important Information and Disclaimer:** The information provided on this page represents TI's knowledge and belief as of the date that it is provided. TI bases its knowledge and belief on information provided by third parties, and makes no representation or warranty as to the accuracy of such information. Efforts are underway to better integrate information from third parties. TI has taken and continues to take reasonable steps to provide representative and accurate information but may not have conducted destructive testing or chemical analysis on incoming materials and chemicals. TI and TI suppliers consider certain information to be proprietary, and thus CAS numbers and other limited information may not be available for release.

In no event shall TI's liability arising out of such information exceed the total purchase price of the TI part(s) at issue in this document sold by TI to Customer on an annual basis.

## TAPE AND REEL INFORMATION



### QUADRANT ASSIGNMENTS FOR PIN 1 ORIENTATION IN TAPE



\*All dimensions are nominal

Device	Package Type	Package Drawing	Pins	SPQ	Reel Diameter (mm)	Reel Width W1 (mm)	A0 (mm)	B0 (mm)	K0 (mm)	P1 (mm)	W (mm)	Pin1 Quadrant
UCC3750DWTR	SOIC	DW	28	1000	330.0	32.4	11.35	18.67	3.1	16.0	32.0	Q1

TAPE AND REEL BOX DIMENSIONS



\*All dimensions are nominal

Device	Package Type	Package Drawing	Pins	SPQ	Length (mm)	Width (mm)	Height (mm)
UCC3750DWTR	SOIC	DW	28	1000	367.0	367.0	55.0



DW (R-PDSO-G28)

PLASTIC SMALL OUTLINE

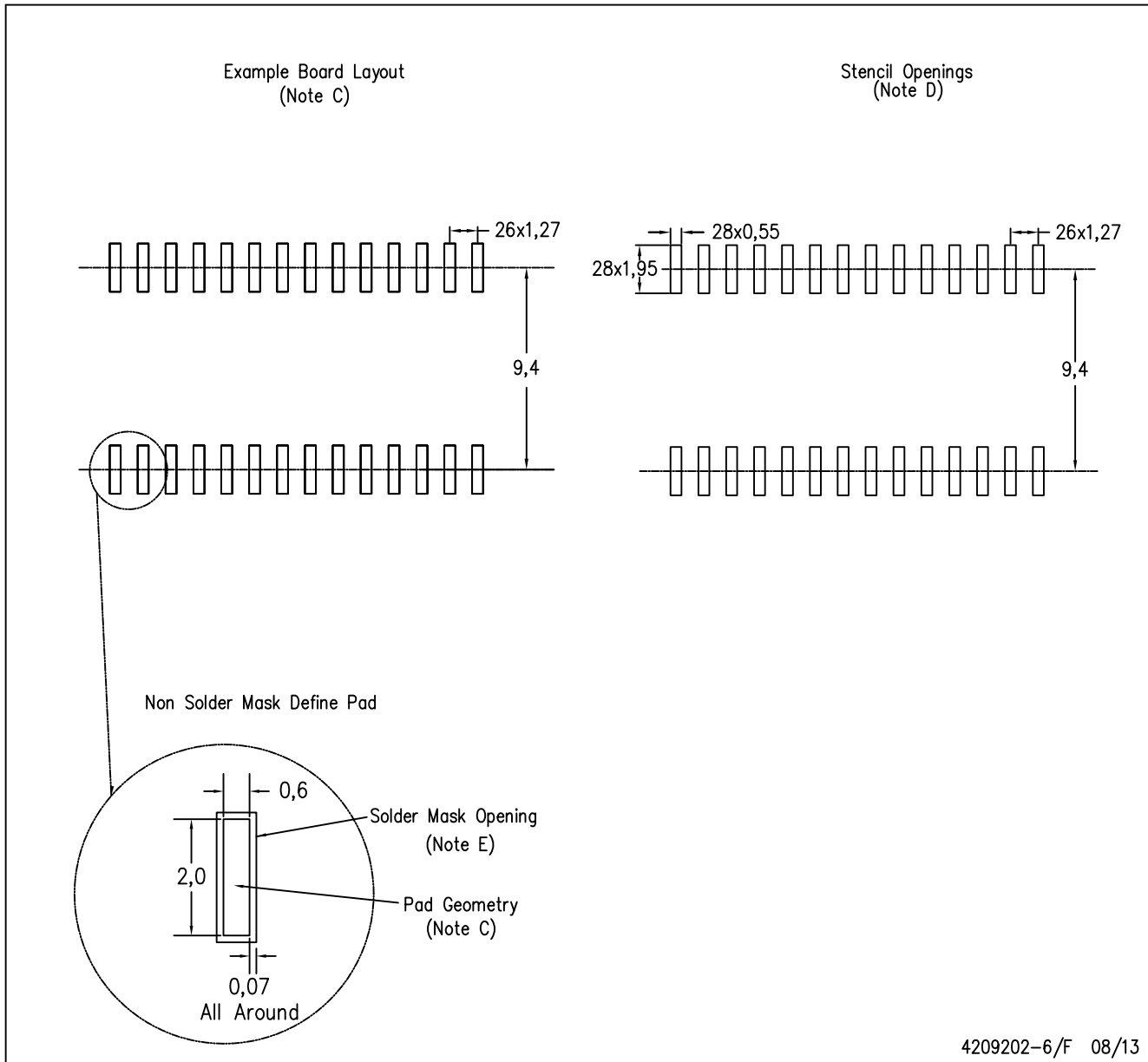

- NOTES:
- All linear dimensions are in millimeters.
  - This drawing is subject to change without notice.
  - Refer to IPC7351 for alternate board design.
  - Laser cutting apertures with trapezoidal walls and also rounding corners will offer better paste release. Customers should contact their board assembly site for stencil design recommendations. Refer to IPC-7525
  - Customers should contact their board fabrication site for solder mask tolerances between and around signal pads.

## IMPORTANT NOTICE

Texas Instruments Incorporated and its subsidiaries (TI) reserve the right to make corrections, enhancements, improvements and other changes to its semiconductor products and services per JESD46, latest issue, and to discontinue any product or service per JESD48, latest issue. Buyers should obtain the latest relevant information before placing orders and should verify that such information is current and complete. All semiconductor products (also referred to herein as "components") are sold subject to TI's terms and conditions of sale supplied at the time of order acknowledgment.

TI warrants performance of its components to the specifications applicable at the time of sale, in accordance with the warranty in TI's terms and conditions of sale of semiconductor products. Testing and other quality control techniques are used to the extent TI deems necessary to support this warranty. Except where mandated by applicable law, testing of all parameters of each component is not necessarily performed.

TI assumes no liability for applications assistance or the design of Buyers' products. Buyers are responsible for their products and applications using TI components. To minimize the risks associated with Buyers' products and applications, Buyers should provide adequate design and operating safeguards.

TI does not warrant or represent that any license, either express or implied, is granted under any patent right, copyright, mask work right, or other intellectual property right relating to any combination, machine, or process in which TI components or services are used. Information published by TI regarding third-party products or services does not constitute a license to use such products or services or a warranty or endorsement thereof. Use of such information may require a license from a third party under the patents or other intellectual property of the third party, or a license from TI under the patents or other intellectual property of TI.

Reproduction of significant portions of TI information in TI data books or data sheets is permissible only if reproduction is without alteration and is accompanied by all associated warranties, conditions, limitations, and notices. TI is not responsible or liable for such altered documentation. Information of third parties may be subject to additional restrictions.

Resale of TI components or services with statements different from or beyond the parameters stated by TI for that component or service voids all express and any implied warranties for the associated TI component or service and is an unfair and deceptive business practice. TI is not responsible or liable for any such statements.

Buyer acknowledges and agrees that it is solely responsible for compliance with all legal, regulatory and safety-related requirements concerning its products, and any use of TI components in its applications, notwithstanding any applications-related information or support that may be provided by TI. Buyer represents and agrees that it has all the necessary expertise to create and implement safeguards which anticipate dangerous consequences of failures, monitor failures and their consequences, lessen the likelihood of failures that might cause harm and take appropriate remedial actions. Buyer will fully indemnify TI and its representatives against any damages arising out of the use of any TI components in safety-critical applications.

In some cases, TI components may be promoted specifically to facilitate safety-related applications. With such components, TI's goal is to help enable customers to design and create their own end-product solutions that meet applicable functional safety standards and requirements. Nonetheless, such components are subject to these terms.

No TI components are authorized for use in FDA Class III (or similar life-critical medical equipment) unless authorized officers of the parties have executed a special agreement specifically governing such use.

Only those TI components which TI has specifically designated as military grade or "enhanced plastic" are designed and intended for use in military/aerospace applications or environments. Buyer acknowledges and agrees that any military or aerospace use of TI components which have **not** been so designated is solely at the Buyer's risk, and that Buyer is solely responsible for compliance with all legal and regulatory requirements in connection with such use.

TI has specifically designated certain components as meeting ISO/TS16949 requirements, mainly for automotive use. In any case of use of non-designated products, TI will not be responsible for any failure to meet ISO/TS16949.

### Products

Audio	<a href="http://www.ti.com/audio">www.ti.com/audio</a>
Amplifiers	<a href="http://amplifier.ti.com">amplifier.ti.com</a>
Data Converters	<a href="http://dataconverter.ti.com">dataconverter.ti.com</a>
DLP® Products	<a href="http://www.dlp.com">www.dlp.com</a>
DSP	<a href="http://dsp.ti.com">dsp.ti.com</a>
Clocks and Timers	<a href="http://www.ti.com/clocks">www.ti.com/clocks</a>
Interface	<a href="http://interface.ti.com">interface.ti.com</a>
Logic	<a href="http://logic.ti.com">logic.ti.com</a>
Power Mgmt	<a href="http://power.ti.com">power.ti.com</a>
Microcontrollers	<a href="http://microcontroller.ti.com">microcontroller.ti.com</a>
RFID	<a href="http://www.ti-rfid.com">www.ti-rfid.com</a>
OMAP Applications Processors	<a href="http://www.ti.com/omap">www.ti.com/omap</a>
Wireless Connectivity	<a href="http://www.ti.com/wirelessconnectivity">www.ti.com/wirelessconnectivity</a>

### Applications

Automotive and Transportation	<a href="http://www.ti.com/automotive">www.ti.com/automotive</a>
Communications and Telecom	<a href="http://www.ti.com/communications">www.ti.com/communications</a>
Computers and Peripherals	<a href="http://www.ti.com/computers">www.ti.com/computers</a>
Consumer Electronics	<a href="http://www.ti.com/consumer-apps">www.ti.com/consumer-apps</a>
Energy and Lighting	<a href="http://www.ti.com/energy">www.ti.com/energy</a>
Industrial	<a href="http://www.ti.com/industrial">www.ti.com/industrial</a>
Medical	<a href="http://www.ti.com/medical">www.ti.com/medical</a>
Security	<a href="http://www.ti.com/security">www.ti.com/security</a>
Space, Avionics and Defense	<a href="http://www.ti.com/space-avionics-defense">www.ti.com/space-avionics-defense</a>
Video and Imaging	<a href="http://www.ti.com/video">www.ti.com/video</a>

### TI E2E Community

[e2e.ti.com](http://e2e.ti.com)