

MM5450/MM5451 LED Display Drivers

General Description

The MM5450 and MM5451 are monolithic MOS integrated circuits utilizing N-channel metal-gate low threshold, enhancement mode, and ion-implanted depletion mode devices. They are available in 40-pin molded or cavity dual-in-line packages. The MM5450/MM5451 is designed to drive common anode-separate cathode LED displays. A single pin controls the LED display brightness by setting a reference current through a variable resistor connected to V_{DD} .

Features

- Continuous brightness control
- Serial data input
- No load signal required
- Enable (on MM5450)
- Wide power supply operation
- TTL compatibility
- 34 or 35 outputs, 15 mA sink capability
- Alphanumeric capability
- θ_{JA} DIP

Board = 49°C/W
Socket = 54°C/W

Applications

- COPSM or microprocessor displays
- Industrial control indicator
- Relay driver
- Digital clock, thermometer, counter, voltmeter
- Instrumentation readouts

Block Diagram

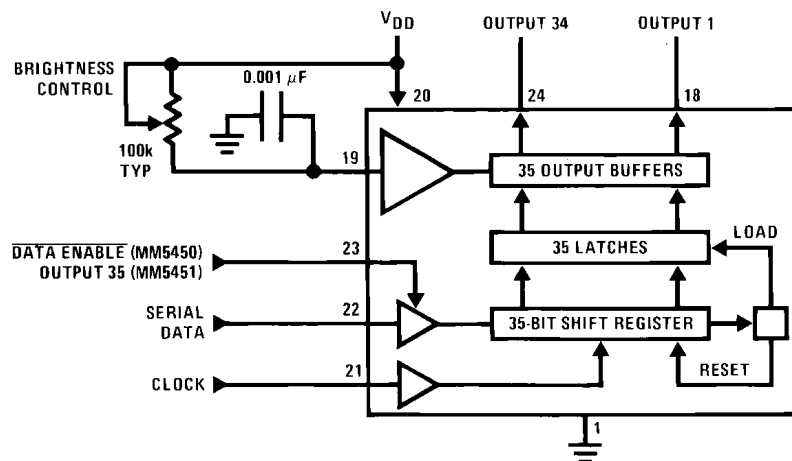

FIGURE 1

TL/F/6136-1

Absolute Maximum Ratings

If Military/Aerospace specified devices are required, please contact the National Semiconductor Sales Office/Distributors for availability and specifications.

Voltage at Any Pin	$V_{SS} - 0.3V$ to $V_{SS} + 12V$
Operating Temperature	-25°C to +85°C
Storage Temperature	-65°C to +150°C
Junction Temperature	+150°C
Lead Temperature (Soldering, 10 sec.)	300°C

Power Dissipation at +25°C

Molded DIP Package, Board Mount	2.5W*
Molded DIP Package, Socket Mount	2.3W**

*Molded DIP Package board mount, $\theta_{JA} = 49^\circ\text{C}/\text{W}$, Derate 20.4 mW/°C above 25°C.

**Molded DIP Package, socket mount, $\theta_{JA} = 54^\circ\text{C}/\text{W}$, Derate 18.5 mW/°C above 25°C.

Electrical Characteristics T_A within operating range, $V_{DD} = 4.75V$ to $11.0V$, $V_{SS} = 0V$ unless otherwise specified

Parameter	Conditions	Min	Typ	Max	Units
Power Supply		4.75		11	V
Power Supply Current	Excluding Output Loads			7	mA
Input Voltages					
Logical "0" Level (V_L)	$\pm 10 \mu\text{A}$ Input Bias	-0.3		0.8	V
Logical "1" Level (V_H)	$4.75V \leq V_{DD} \leq 5.25V$	2.2		V_{DD}	V
	$V_{DD} > 5.25V$	$V_{DD} - 2V$		V_{DD}	V
Brightness Input (Note 2)		0		0.75	mA
Output Sink Current					
Segment OFF	$V_{OUT} = 3.0V$			10	μA
Segment ON	$V_{OUT} = 1V$ (Note 3) Brightness Input = $0 \mu\text{A}$ Brightness Input = $100 \mu\text{A}$ Brightness Input = $750 \mu\text{A}$	0 2.0 15	2.7	10 4 25	μA mA mA
Brightness Input Voltage (Pin 19)	Input Current $750 \mu\text{A}$	3.0		4.3	V
Output Matching (Note 1)				± 20	%
Clock Input	(Notes 5 and 6)				
Frequency, f_C				500	kHz
High Time, t_H		950			ns
Low Time, t_L		950			ns
Data Input					
Set-Up Time, t_{DS}		300			ns
Hold Time, t_{DH}		300			ns
Data Enable Input					
Set-Up Time, t_{DES}		100			ns

Note 1: Output matching is calculated as the percent variation $(I_{MAX} + I_{MIN})/2$.

Note 2: With a fixed resistor on the brightness input pin, some variation in brightness will occur from one device to another. Maximum brightness input current can be 2 mA as long as Note 3 and junction temperature equation are complied with.

Note 3: See Figures 5, 6, and 7 for Recommended Operating Conditions and limits. Absolute maximum for each output should be limited to 40 mA.

Note 4: The V_{OUT} voltage should be regulated by the user. See Figures 6 and 7 for allowable V_{OUT} vs I_{OUT} operation.

Note 5: AC input waveform specification for test purpose: $t_r \leq 20$ ns, $t_f \leq 20$ ns, $f = 500$ kHz, 50% $\pm 10\%$ duty cycle.

Note 6: Clock input rise and fall times must not exceed 300 ns.

Connection Diagrams

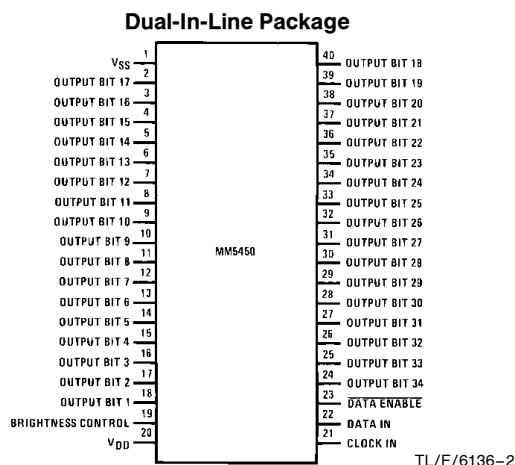

Top View
FIGURE 2a

Order Number MM5450N, MM5451N, MM5450V or MM5451V
See NS Package Number N40A or V44A

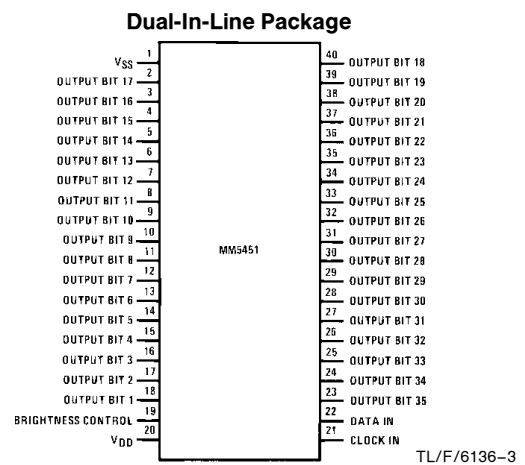

Top View
FIGURE 2b

Connection Diagrams (Continued)

Plastic Chip Carrier

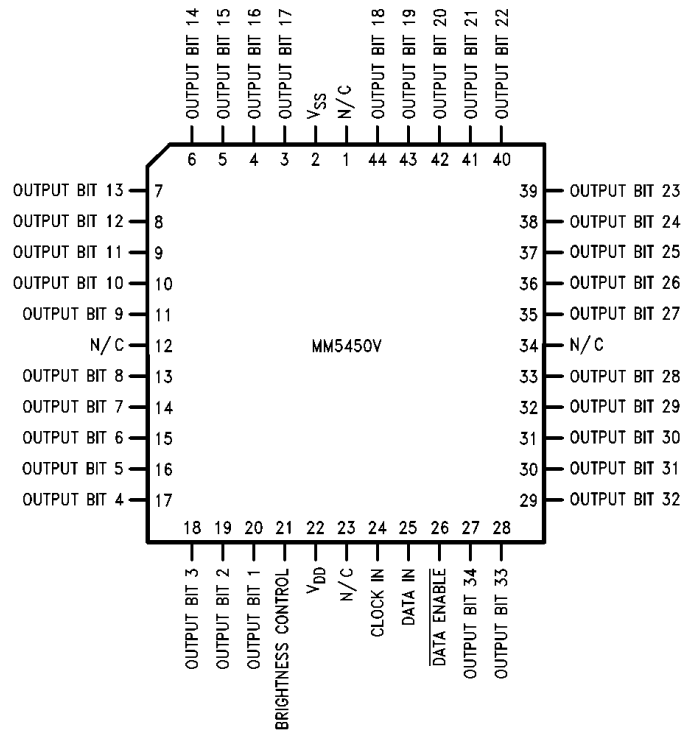

Top View

TL/F/6136-13

Plastic Chip Carrier

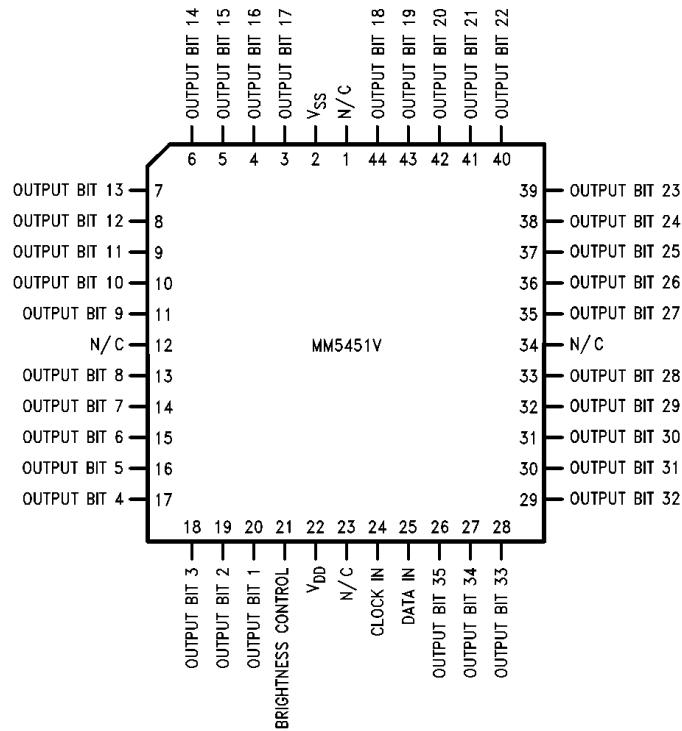

Top View

TL/F/6136-14

Functional Description

Both the MM5450 and the MM5451 are specifically designed to operate 4- or 5-digit alphanumeric displays with minimal interface with the display and the data source. Serial data transfer from the data source to the display driver is accomplished with 2 signals, serial data and clock. Using a format of a leading "1" followed by the 35 data bits allows data transfer without an additional load signal. The 35 data bits are latched after the 36th bit is complete, thus providing non-multiplexed, direct drive to the display. Outputs change only if the serial data bits differ from the previous time. Display brightness is determined by control of the output current for LED displays. A 0.001 capacitor should be connected to brightness control, pin 19, to prevent possible oscillations.

A block diagram is shown in *Figure 1*. For the MM5450 a $\overline{\text{DATA ENABLE}}$ is used instead of the 35th output. The $\overline{\text{DATA ENABLE}}$ input is a metal option for the MM5450. The output current is typically 20 times greater than the current into pin 19, which is set by an external variable resistor. There is an internal limiting resistor of 400Ω nominal value.

Figure 4 shows the input data format. A start bit of logical "1" precedes the 35 bits of data. At the 36th clock a LOAD signal is generated synchronously with the high state of the clock, which loads the 35 bits of the shift registers into the latches. At the low state of the clock a RESET signal is generated which clears all the shift registers for the next set of data. The shift registers are static master-slave configuration. There is no clear for the master portion of the first shift register, thus allowing continuous operation.

There must be a complete set of 36 clocks or the shift registers will not clear.

When the chip first powers ON an internal power ON reset signal is generated which resets all registers and all latches. The START bit and the first clock return the chip to its normal operation.

Figure 2 shows the pin-out of the MM5450 and MM5451. Bit 1 is the first bit following the start bit and it will appear on pin 18. A logical "1" at the input will turn on the appropriate LED.

Figure 3 shows the timing relationships between data, clock and $\overline{\text{DATA ENABLE}}$. A max clock frequency of 0.5 MHz is assumed.

For applications where a lesser number of outputs are used, it is possible to either increase the current per output, or operate the part at higher than 1V V_{OUT} . The following equation can be used for calculations.

$$T_j = (V_{\text{OUT}}) (I_{\text{LED}}) (\text{No. of segments})(\theta_{\text{JA}}) + T_A$$

where:

T_j = junction temperature, 150°C max

V_{OUT} = the voltage at the LED driver outputs

I_{LED} = the LED current

θ_{JA} = thermal coefficient of the package

T_A = ambient temperature

θ_{JA} (Socket Mount) = 54°C/W

θ_{JA} (Board Mount) = 49°C/W

The above equation was used to plot *Figure 5*, *Figure 6* and *Figure 7*.

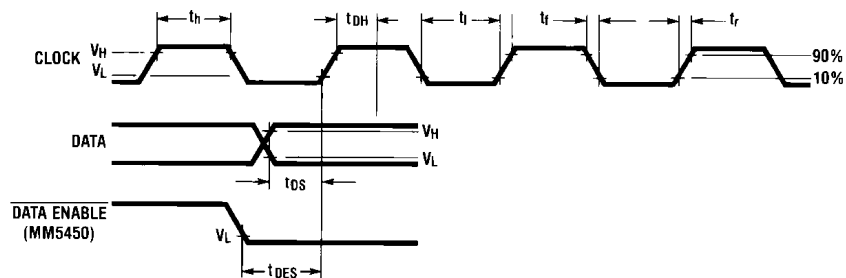

FIGURE 3

TL/F/6136-4

Functional Description (Continued)

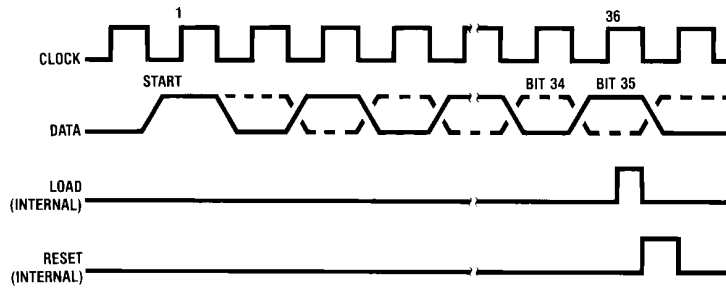
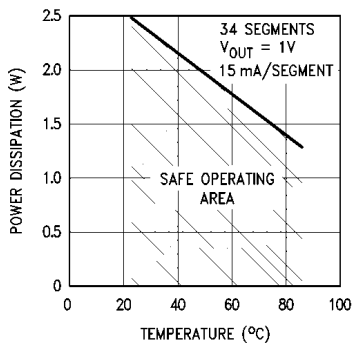

FIGURE 4. Input Data Format

TL/F/6136-5

Typical Performance Characteristics



TL/F/6136-6

FIGURE 5

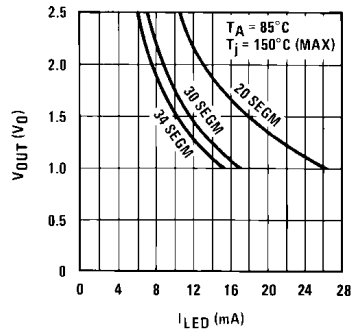

TL/F/6136-7

FIGURE 6

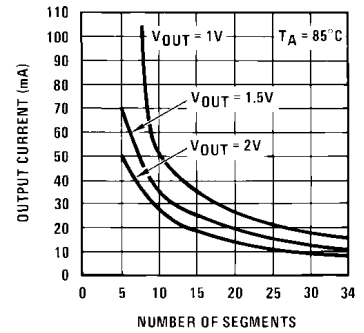

TL/F/6136-8

FIGURE 7

Typical Applications

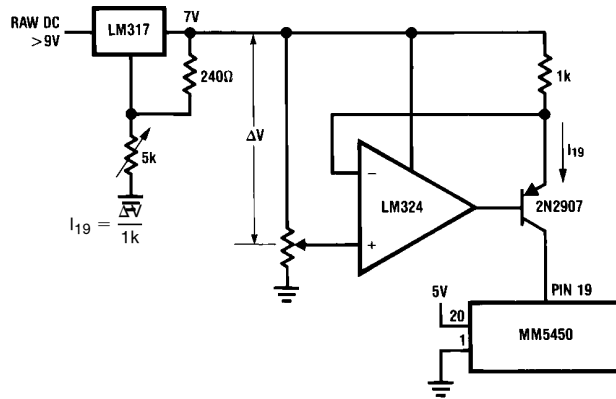

TL/F/6136-9

FIGURE 8. Typical Application of Constant Current Brightness Control

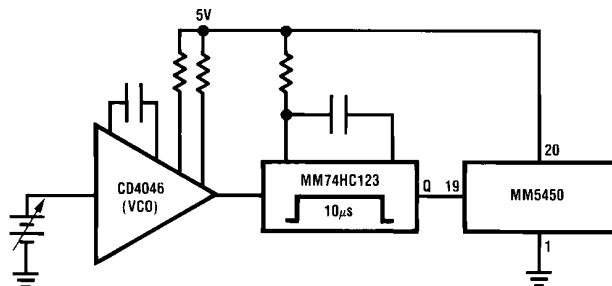

TL/F/6136-10

FIGURE 9. Brightness Control Varying the Duty Cycle

Typical Applications (Continued)

Basic Electronically Tuned Radio System

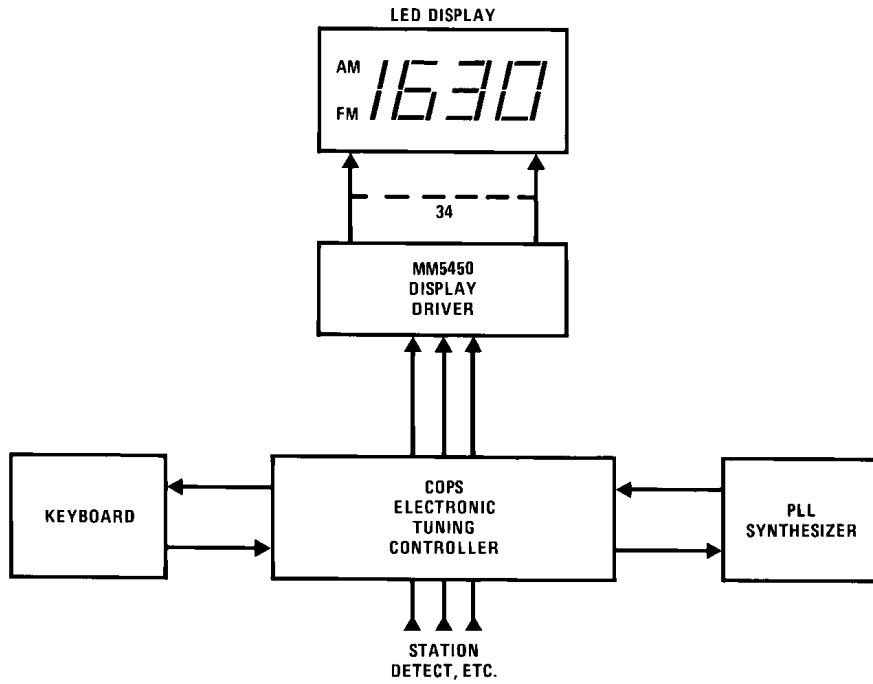

TL/F/6136-11

Duplexing 8 Digits with One MM5450

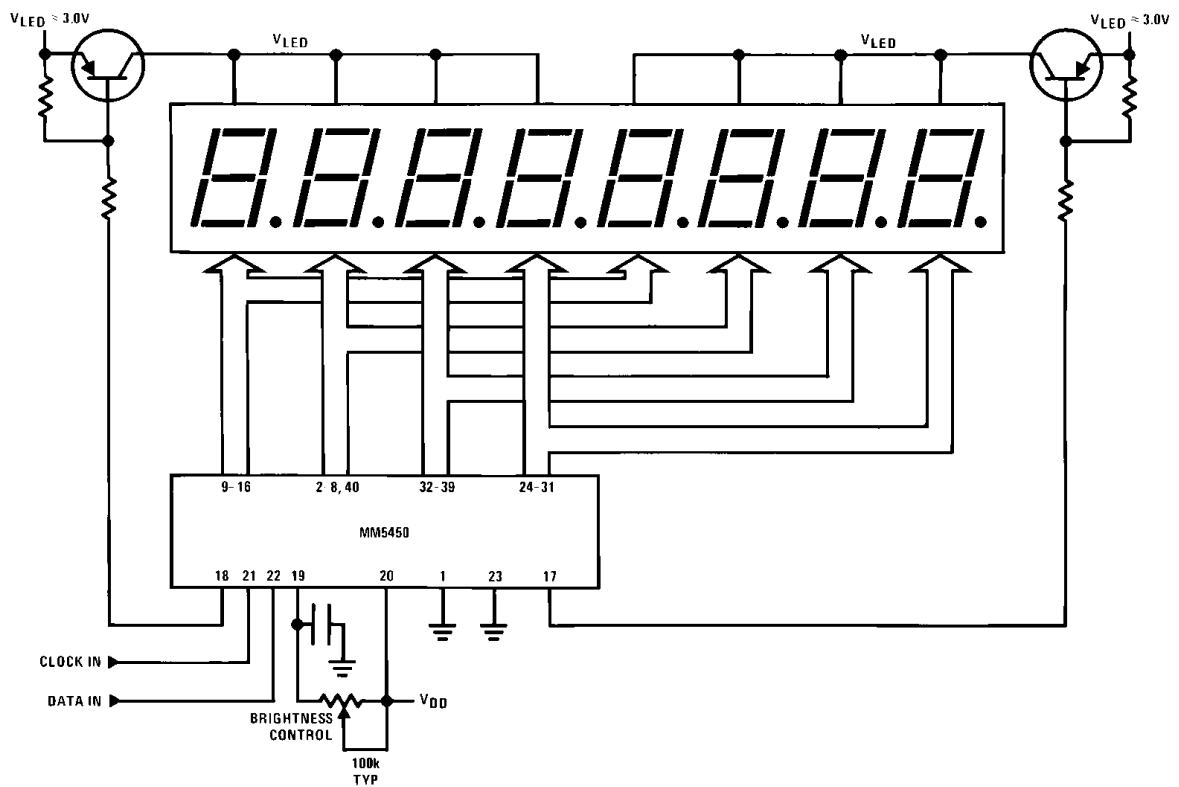

TL/F/6136-12

Physical Dimensions inches (millimeters)

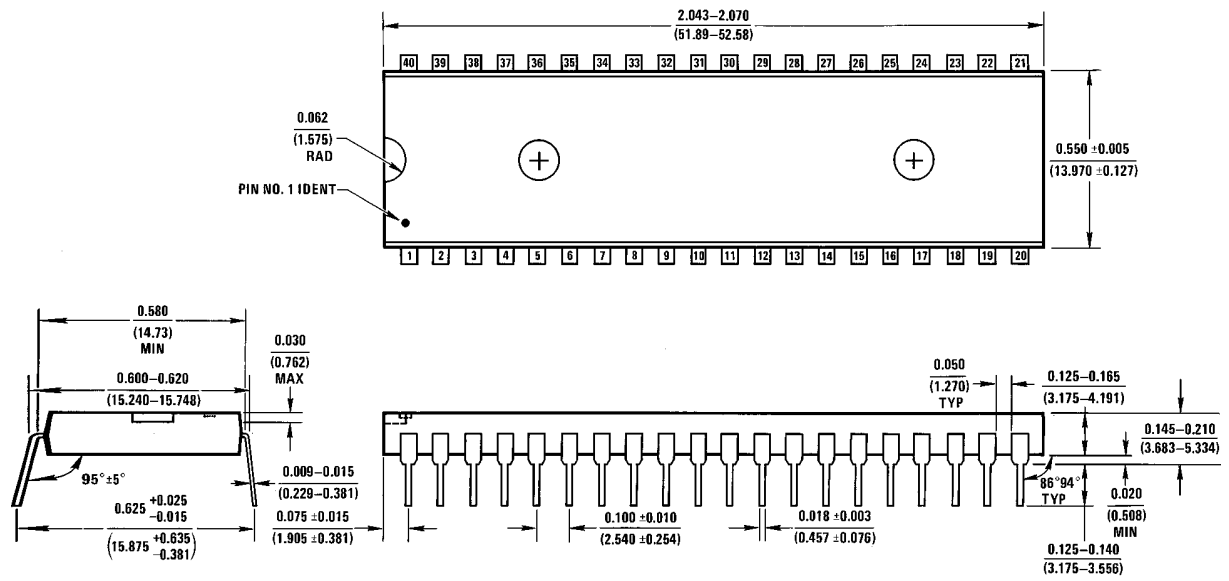

Molded Dual-In-Line Package (N)
Order Number MM5450N or MM5451N
NS Package Number N40A

N40A (REV E)

Physical Dimensions inches (millimeters) (Continued)

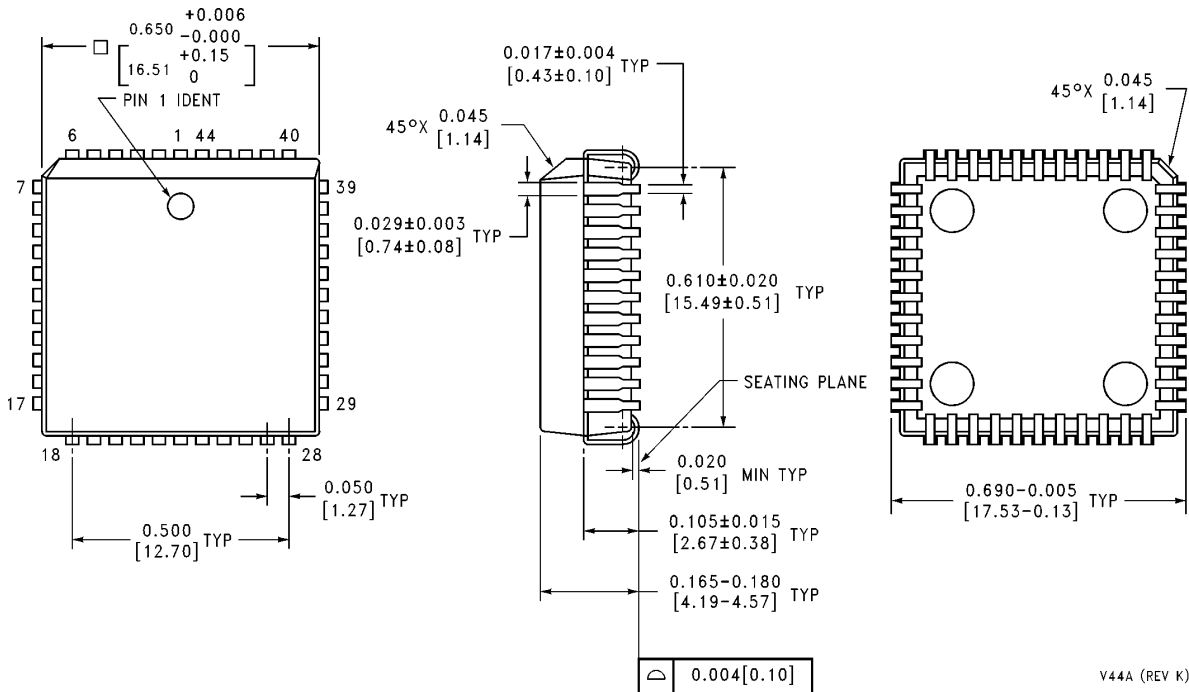

V44A (REV K)

Plastic Chip Carrier (V)
Order Number MM5450V or MM5451V
NS Package Number V44A

LIFE SUPPORT POLICY

NATIONAL'S PRODUCTS ARE NOT AUTHORIZED FOR USE AS CRITICAL COMPONENTS IN LIFE SUPPORT DEVICES OR SYSTEMS WITHOUT THE EXPRESS WRITTEN APPROVAL OF THE PRESIDENT OF NATIONAL SEMICONDUCTOR CORPORATION. As used herein:

1. Life support devices or systems are devices or systems which, (a) are intended for surgical implant into the body, or (b) support or sustain life, and whose failure to perform, when properly used in accordance with instructions for use provided in the labeling, can be reasonably expected to result in a significant injury to the user.
2. A critical component is any component of a life support device or system whose failure to perform can be reasonably expected to cause the failure of the life support device or system, or to affect its safety or effectiveness.



National Semiconductor Corporation
 1111 West Bardin Road
 Arlington, TX 76017
 Tel: 1(800) 272-9959
 Fax: 1(800) 737-7018

National Semiconductor Europe
 Fax: (+49) 0-180-530 85 86
 Email: cnjwge@tevm2.nsc.com
 Deutsch Tel: (+49) 0-180-530 85 85
 English Tel: (+49) 0-180-532 78 32
 Français Tel: (+49) 0-180-532 93 58
 Italiano Tel: (+49) 0-180-534 16 80

National Semiconductor Hong Kong Ltd.
 13th Floor, Straight Block,
 Ocean Centre, 5 Canton Rd.
 Tsimshatsui, Kowloon
 Hong Kong
 Tel: (852) 2737-1600
 Fax: (852) 2736-9960

National Semiconductor Japan Ltd.
 Tel: 81-043-299-2309
 Fax: 81-043-299-2408

This datasheet has been downloaded from:

www.DatasheetCatalog.com

Datasheets for electronic components.

National Semiconductor was acquired by Texas Instruments.

http://www.ti.com/corp/docs/investor_relations/pr_09_23_2011_national_semiconductor.html

This file is the datasheet for the following electronic components:

MM5450V - <http://www.ti.com/product/mm5450v?HQS=TI-null-null-dscatalog-df-pf-null-wwe>

MM5451N - <http://www.ti.com/product/mm5451n?HQS=TI-null-null-dscatalog-df-pf-null-wwe>

MM5451V - <http://www.ti.com/product/mm5451v?HQS=TI-null-null-dscatalog-df-pf-null-wwe>

MM5450N - <http://www.ti.com/product/mm5450n?HQS=TI-null-null-dscatalog-df-pf-null-wwe>